



moulton niguel water district

STANDARD SPECIFICATIONS

**FOR CONSTRUCTION OF POTABLE WATER,
RECYCLED WATER, AND WASTEWATER FACILITIES**

**STANDARD
SPECIFICATIONS
FOR
THE CONSTRUCTION OF
POTABLE WATER, RECYCLED WATER,
AND WASTEWATER FACILITIES**

Approved by:



**Todd Dmytryshyn
Director of Engineering
RCE 81461**

August 2024

**MOULTON NIGUEL WATER DISTRICT
26161 Gordon Road
Laguna Hills, CA 92653
(949) 831-2500**

MOULTON NIGUEL WATER DISTRICT
STANDARD SPECIFICATIONS FOR THE CONSTRUCTION OF
POTABLE WATER, RECYCLED WATER,
AND WASTEWATER FACILITIES

TABLE OF CONTENTS

<u>Section</u>	<u>Title</u>
I	Potable Water Facilities Design Criteria
II	Off-Site Recycled Water Facilities Design Criteria
III	Wastewater Facilities Design Criteria
IV	Standard Technical Specifications
V	Standard Drawings
VI	Approved Material List

Section I

Potable Water Facilities Design Criteria

POTABLE WATER FACILITIES DESIGN CRITERIA

1.01 WATER MAIN DESIGN

A. Minimum Size Mains

1. The normal minimum size distribution main shall be 8-inch, unless otherwise accepted by the District.

B. Design Flow and Pipe Velocity Criteria

1. Velocity Criteria: The criteria for velocity shall be as described herein. The maximum velocity in a line shall not exceed 7 fps (feet per second) during the peak hour condition. The peak hour is defined as 3 times the average day demand. The maximum velocity in a line shall not exceed 10 fps during the maximum day plus fire demand condition. The maximum day is defined as 2 times the average day demand.
2. Fire Flow Demand: The design criteria to be used for determining fire flow requirements shall be the actual fire flow requirements as determined by the Orange County Fire Authority and the “Fire Master Plans for Commercial & Residential Development”; latest revision. Before designing the potable water system for a project, the Applicant shall complete the Orange County Fire Marshal's water availability form for the project and submit to the District. Indication of the Fire Marshal's approval is required to be on the improvement plans prior to the District's acceptance. All fireflow tests shall be performed by the District using the District's hydraulic model. The District shall charge a fee to perform this fireflow test.

C. Type of Water Main Pipe

1. 8-inch and 12-inch diameter pipes: C900 PVC pipe, DR-14. Where ductile-iron pipe is required by the District, provide Class 350 pipe.
2. 16-inch through 20-inch diameter pipes: C900 PVC pipe, DR-14, ductile-iron pipe, or CML&C steel pipe
3. 24, 30 and 36-inch diameter pipes: CML&C steel pipe
4. Non-buried piping shall be metallic.
5. Class of pipe shall be in accordance with pressure requirements provided by the District.

D. Minimum Depth to Top of Water Main Pipe

1. Distribution Mains (12-inch diameter and smaller): The top of the pipe is to be a minimum of 42 inches below finished grade.
2. Transmission Mains (Larger than 12-inch diameter): The top of the pipe is to be a minimum of 48 inches below finished grade.

1.02 WATER LAYOUT DESIGN

A. Standard Location

1. Potable water main center-lines shall normally be located 6 feet from the curb face and may be deflected to avoid cross gutters, concrete bus lanes, or other interferences. Deflection shall be limited to 50-percent of manufacturer's recommended deflection for AWWA compliant pipe products. Note that some manufacturers do not allow deflection at joints for PVC.

B. Isolation Valves

1. Type:
 - a. Butterfly valves shall only be used on lines 16-inch diameter and larger or as specifically shown on the plans.
 - b. Resilient wedge gate valves shall be used on lines 4-inch through 12-inch diameter.
2. Fittings: Generally the District requires all fittings and valves to have "push-on" type ends, except at tees and crosses where valves are required. Valve and fitting are to be joined by a flange.
3. Spacing
 - a. As a general rule, there should be three (3) valves where one main ties into another. Where two mains cross, there shall be four (4) valves. On long blocks, intermediate valves should be installed so that only a maximum of 20 lots or 600 feet, whichever is less, would have to be shut off at any one time.
 - b. Valves should also be spaced so that not more than two fire hydrants should be out of service at any one time.
 - c. In most cases where water mains pass through easements outside traveled streets, a valve shall be located at each end of the easement.
 - d. The final determination of valves and locations shall be per the District.

C. Automatic Control Valves

1. Automatic control valves shall be installed above ground or within a vault to provide for adjustment, maintenance and repair. Direct burial of a control valve will not be permitted under any circumstance.
2. Automatic control valves are to be installed with ductile iron piping or cement-mortar lined and coated steel pipes.

D. Fire Hydrant Locations

1. The location of fire hydrants shall be as determined by the Orange County Fire Marshal, and per the guidelines set herein. The exact location with respect to the curb and sidewalk shall be as shown in District Standard Drawing W-7.
 - a. Fire Hydrant spacing
 - 1) The maximum fire hydrant separation shall be 300 feet from fire hydrant to fire hydrant. The only exceptions will be at the discretion of the Fire Marshal.
 - 2) Fire hydrants shall be located near the beginning of curb return (BCR) or lot lines.

- 3) No fire hydrant shall be located within 3 feet of a driveway, or closer than 40 feet to any structure, unless approved by the Fire Marshal.
 - 4) In situations where the fire hydrant run is over 100 feet or where the Orange County Fire Authority flow rate requirements exceed 1,500 gpm for any hydrant, the size of the lateral for that hydrant shall be 8-inch diameter. In situations where the residual pressure is low, the District may require larger diameter hydrant laterals.
- b. Types of Hydrants
 - 1) Wet barrel all- bronze type hydrants, as specified by the District, are to be used except in hill areas or special "high-risk" situations where the District may require a wet barrel with check valve.
 - c. Plan Requirements
 - 1) Fire hydrants shall be shown on the plans where the hydrant is to be located with respect to the property line, and easements that will be provided. The building foot prints or building pad areas are also to be shown.
- E. Blow-Offs
1. Fire hydrant assemblies shall be installed at ends and at low points on mains 12-inch diameter and smaller.
 2. On mains 16-inch diameter and larger, use of blow-offs versus fire hydrants at ends and low points will be as directed by the District.
 - a. Blow-offs shall be installed in a level section of pipe.
 - b. Blow-offs shall not be connected to any sewer, submerged in any stream, or installed in any manner that will permit back siphoning into the distribution system.
 3. Temporary blow-offs shall be installed as service stub-outs for testing and flushing purposes.
- F. Air Valves
1. Air vacuum and release valves are to be installed at all high points in the line, per requirements of AWWA M51, and as directed by the District. Air vacuum and release valves shall be installed in above ground enclosures accepted by the District.
 - a. Air-Release Valve Criteria: Size per AWWA M51 to release 2-percent of the flowrate of water passing through the system in terms of air at standard conditions.
 - b. Air/Vacuum Valve Criteria: Size per AWWA M51 to accommodate filling and draining of pipeline.
- G. Separation of Potable Water from Sewer and Recycled Water Lines
1. The State Water Resources Control Board (SWRCB) and State of California regulations (Title 22, Chapter 16 Section 64572) shall be followed when designing and constructing new potable water, recycled water, and sewer mains. When SWRCB and District standards conflict, the most stringent requirement shall apply unless otherwise accepted by the District.

- a. Horizontal Separation
 - 1) The Regional Water Quality Control Board regulations require a 10-foot minimum separation between potable water and sewer mains. However, in special situations where there is no alternative but to install the mains with less than the required separation, special construction will be considered on an individual basis by the District for acceptance.
 - 2) Minimum separation of potable water service line and a storm drain or recycled water line shall be 4 feet.
 - 3) Minimum separation of potable water service line and sewer lateral shall be 5 feet.
 - 4) Potable water lines are normally located on the opposite side of the street from the recycled water line.
- b. Vertical Separation
 - 1) Normally, potable water, recycled water, and sewer mains shall be located vertically from the street surface in order of the higher quality, i.e., potable water shall be above recycled water and recycled water shall be above sewer.
 - 2) Whenever a crossing must occur where a sewer or recycled water main crosses within 1 foot below a potable water main, special construction will be required and accepted on an individual basis by the District.
 - 3) These construction requirements shall not apply to house laterals that cross perpendicular less than 1 foot below a pressure water main.

H. Trenchless Construction

- 1. Tunneling will not be permitted.
- 2. The use of a jack and bore or hydraulic ram may be employed if accepted by the District.

1.03 WATER SERVICE DESIGN

A. Minimum Potable Service Size

- 1. Minimum potable service line size shall be 3/4-inch diameter with a 3/4-inch meter. The sizing of the service shall be specified on the plans designated by lot numbers. Services for commercial or industrial developments are to be as shown on plans or as directed by the District.
- 2. Minimum potable service line size shall be 1-inch diameter if serving a sprinkler system.
- 3. Meters shall be the same size as the service line, except where the meter size is 3-inch. Where this occurs, the pipe is to be 4-inch diameter reduced to 3-inch diameter at the meter. Reducers shall be located inside the meter vault.

B. Type of Service Line

- 1. Acceptable service line material is as described below:
 - a. 3/4-inch through 2-inch diameter service line shall be copper tubing.
 - b. 4-inch diameter and larger shall be DIP per Section 15056, or PVC per Section 15064, as determined by the District (3-inch size not District Standard - use 4-inch piping up to meter).

C. Meters

1. Sizing:
 - a. All meters shall be appropriately sized by the Applicant in accordance with the California Plumbing Code.
 - b. Evidence of sizing shall be submitted to the District for review and acceptance prior to installation.
2. Bypass line:
 - a. A bypass line shall be installed on all commercial meter assemblies 3-inch and larger. A bypass line is not required on irrigation services, or as determined by the District.
 - b. A bypass line may be required on smaller installations which require continuous service.
3. Special cases meter types: For special cases where meters are needed for non-customer applications, such as for pump stations, use propeller meters and magnetic flowmeters listed in the specifications as directed by the District.

D. Pressure Regulating Valves

1. Individual pressure regulators shall be installed and set per California Plumbing Code or appropriate governing agency's standards.

E. Backflow Preventers

1. Application
 - a. A backflow prevention assembly shall be installed at all locations where the potential for a backflow condition into the District's potable water mains exists. The assembly shall be located immediately downstream of the meter assembly.
 - b. The type of backflow prevention assembly required will depend on the level of potential hazard which exists. The District will make the final determination of what type of backflow prevention assembly is required.
 - c. Any service providing potable water to anything other than a private residential dwelling shall have a backflow prevention assembly at the meter.
 - d. An above ground backflow prevention assembly with detector assembly is required on a private on-site fire protection system connected to the District's potable water mains.
2. Responsibility
 - a. The District will maintain only the upstream mainline shut-off valve and service to first fitting. The owner is responsible for the testing; maintenance of the backflow assembly, piping, fittings, connections and valves including point of connection; and repair or replacement of the assembly.

1.04 RESTORATION AND CLEANUP

- A. The Contractor shall restore or replace all removed, damaged, or otherwise disturbed existing surfaces or structures not otherwise noted on the plans or specified herein to a condition equal to that before the work began and to the satisfaction of the District, City, or other agency having jurisdiction. All excess earth and all other debris shall be removed and disposed of by the Contractor and the entire site of the work shall be left in a condition acceptable to the District prior to final acceptance of the work. All restoration and cleanup shall be performed in accordance with the District's Standard Specifications.

1.05 STANDARD WATER NOTES

- A. Include all General Construction Notes and General Potable Water Notes, as listed in the Standard Drawings, on all facility improvement plans or potable water system construction plans.

END OF SECTION

Section II

Off-Site Recycled Water Facilities Design Criteria

OFF-SITE RECYCLED WATER FACILITIES DESIGN CRITERIA

1.01 GENERAL

- A. Design of all off-site recycled water facilities shall be as set forth under the Rules and Regulations for Users of Recycled Water, and "Potable Water Facilities Design Criteria," herein, except as modified or expanded upon in the following sections.

1.02 RECYCLED WATER LAYOUT DESIGN

A. Location

- 1. Recycled water mains shall be located 6 feet from curb face on the opposite side of the street of the potable water mains and shall meet all separation requirements stated herein.
- 2. Recycled water mains shall have a minimum of 48 inches cover to the roadway surface.

B. Valves:

- 1. Spacing: On long blocks, intermediate valves shall be provided upon request of the District.

C. Separation of Recycled Water from Sewer and Potable Water Lines

- 1. The State Water Resources Control Board (SWRCB) and State of California regulations (Title 22, Chapter 16 Section 64572) shall be followed when designing and constructing new potable water, recycled water, and sewer mains. When SWRCB and District standards conflict, the most stringent requirement shall apply unless otherwise accepted by the District.

a. Horizontal Separation

- 1) The Regional Water Quality Control Board regulations require a 10-foot minimum separation between recycled water and sewer water mains. However, in special situations where there is no alternative but to install the mains with less than the required separation, special construction will be required and accepted on an individual basis by the District.
- 2) Minimum separation of potable water service line and a recycled water line shall be 4 feet.
- 3) Minimum separation of recycled water service line and sewer lateral shall be 5 feet.
- 4) Recycled water lines are normally located on the opposite side of the street from the sewer or potable water line.

b. Vertical Separation

- 1) Normally, potable water, recycled water, and sewer mains shall be located vertically from the street surface in order of the higher quality, i.e., potable water shall be above recycled water and recycled water shall be above sewer.
- 2) Whenever a crossing must occur where a recycled water main crosses within 1 foot below a sewer or potable water main, special construction will be required and accepted on an individual basis by the District.

- 3) These construction requirements shall not apply to house laterals that cross perpendicular less than 1 foot below a pressure water main.

1.03 SPECIAL OFF-SITE RECYCLED WATER NOTES

- A. Include all General Construction Notes, General Potable Water Notes, and General Off-Site Recycled Water Notes, as listed in the Standard Drawings, on all recycled water system construction plans.

END OF SECTION

Section III

Wastewater Facilities Design Criteria

WASTEWATER FACILITIES DESIGN CRITERIA

1.01 SEWER PIPE DESIGN

A. Peak Flows

1. Design peak wet weather flows in pipelines 12 inches in diameter and smaller are to be limited to $d/D = 0.5$, where d = depth of flow and D = diameter of pipe. Pipes over 12 inches are to be limited to $d/D = 0.75$.

B. Generation Rates

1. Sewerage generation rates for various developments within the District shall be as established by the District.

C. Piping Schedule

1. Unless noted otherwise on the plans or in the specifications, pipe shall be furnished in accordance with the following materials schedule.
 - a. Sewer mains shall be the following when less than or equal to 15-inch diameter and between 4 and 15-foot depths:
 - 1) Polyvinyl Chloride (PVC) Pipe ASTM D3034 SDR-35
 - 2) Vitrified Clay Pipe (VCP) ASTM C700
 - b. Engineering calculations submitted to the District for acceptance are required for the following piping situations:
 - 1) All pipe 18-inch diameter and larger
 - 2) All pipe with depth (measured from invert elevation) greater than 15-feet, or less than 4-feet
 - c. The District may allow the use of the following pipe by special permission only:
 - 1) High Density Polyethylene (HDPE) ASTM F714
 - 2) PVC ASTM D3034 SDR-26
 - 3) PVC ASTM F679

D. Minimum Size

1. The District will not accept any sewerline smaller than 8 inches nor any sewerline that is within a common trench (two or more utilities in the same trench).

E. Minimum and Maximum Slope Design

1. Slopes

- a. All sewers shall be so designed and constructed to give mean velocities, when flowing half full, of not less than 2.0 fps, based on Manning’s Formula using an “n” value of 0.013. The following are minimum slopes; however, slopes greater than these are desirable:

<u>Sewer Size (inches)</u>	<u>Minimum Slope in Feet per 100 Feet</u>	
8	0.004	(0.40%)
10	0.0032	(0.32 %)
12	0.0028	(0.28%)
15	0.0022	(0.22%)

- b. Maximum slopes shall be 15% unless authorized by the District.
- c. Inverted siphons will only be allowed at locations accepted by the District.

F. High Velocity Protection

1. Where flow velocities greater than 10 fps are attained, special provisions shall be made to protect against displacement by erosion and shock for pipe entering a manhole and for concrete manhole base and flow channels.

G. Minimum Cover

1. Minimum cover from finish street grade to top of sewer main pipe is to be 7 feet, unless otherwise accepted by the District.

1.02 SEWER LAYOUT DESIGN

- A. Location: Wherever possible, in local residential and industrial streets, pipe is to be located 5 feet off the street centerline. In major, primary, and secondary highways, pipe will be located in the center of the driving lane nearest to the center of the street. Pipe will not be located in median strips or parking lanes. Sewer pipe shall generally be laid in straight runs from manhole to manhole. Sewer pipe shall not be installed using horizontal or vertical curves, unless special permission is obtained from the District.

1. Alignment

- a. Barring other limiting design and construction considerations, a maximum separation between sewer and potable water mains in new subdivisions shall be achieved by the following construction procedures:
 - 1) Sewer mains should be installed on the opposite side of the street centerline from the potable water mains.

- 2) If horizontal curves are accepted by the District on curvilinear streets, the sewers shall parallel as nearly as possible the street centerline.
- B. Radius of Curvature: Joint deflections shall be a maximum of 50% of the manufacturer's recommended value for the size and material of pipe to be used.
- C. Stationing Procedure: Sewer centerline stationing shall be shown (example: 0+00) and be independent of street stationing with the stationing starting at the most downstream manhole or connection to existing sewer. All manholes are to be numbered (example MH no. 1).
- D. Manhole Spacing and Location: Manholes shall be installed at the end of each line; at all changes in grade, size, or alignment; at all intersections; and at distances not greater than 400 feet for 8- through 15-inch sewers and 500 feet for 18- to 30-inch sewers.
- E. Separation of Sewer from Potable Water and Recycled Water Lines
1. The State Water Resources Control Board (SWRCB) and State of California regulations (Title 22, Chapter 16 Section 64572) shall be followed when designing and constructing new potable water, recycled water, and sewer mains. When SWRCB and District standards conflict, the most stringent requirement shall apply unless otherwise accepted by the District.
 - a. Horizontal Separation
 - 1) The Regional Water Quality Control Board regulations require a 10-foot-minimum separation between potable water and sewer mains. However, in special situations where there is no alternative but to install the mains with less than the required separation, special construction will be required and accepted on an individual basis by the District.
 - 2) Minimum separation of potable water service line and sewer lateral shall be 5 feet.
 - 3) Sewer lines are normally located on the opposite side of the street from the potable water or recycled water line.
 - b. Vertical Separation
 - 1) Normally, potable water, recycled water, and sewer mains shall be located vertically from the street surface in order of the higher quality, i.e., potable water shall be above recycled water and recycled water shall be above sewer.
 - 2) Whenever a crossing must occur where a sewer main crosses above a potable water or recycled water main or within 1-foot below a potable water or recycled water main, special construction will be will be required and accepted on an individual basis by the District.
 - 3) These construction requirements shall not apply to house laterals that cross perpendicular less than 1 foot below a pressure water main.
- F. Trenchless Construction
1. Tunneling will not be permitted.
 2. The use of a jack and bore or hydraulic ram may be employed if accepted by the District.

1.03 MANHOLES

A. Manhole Depth and Size

1. Manhole depth is calculated from finish grade to lowest pipe invert. Minimum manhole depth is to be 8 feet. The standards for the District sewers call for a depth criteria of about 8 feet to 12 feet for manholes. However, if larger-depth manholes are required and accepted by the District, the following criteria will govern. Manholes shall be pre-cast reinforced concrete with eccentric cone style. The minimum diameter of manholes shall be as follows:

<u>Depth, feet</u>	<u>Manhole Diameter, in</u>
<12	48
≥12	60

2. Depth of manhole shall be measured from the pipe invert to the finished surface of the street with a tolerance of ± 6 inches.
3. For larger sized sewer mains or special circumstances, the manhole size will be as shown on plans.

B. Allowable Elevation Change through Manholes

1. Allowable elevation change through manholes shall be as follows:
 - a. Straight run through manholes based on 0.10 foot loss
 - b. Right angle turn in manholes based on 0.5 velocity head loss or 0.20 foot, whichever is greater

C. Manhole Covers

1. Provide cast-iron manhole frame and covers for manholes installed in paved areas.
2. For non-paved areas with no vehicular or pedestrian access, or any elevated manholes, provide composite frame and covers.

D. Position of Covers

1. In new street developments, the manhole top shall be left at least 6 inches below subgrade. A heavy metal top with cleats the size of the manhole opening shall be mortared tight to the top. Specially cut plywood shall be placed in the bottom of the manhole before the temporary cover is installed. At the completion of final paving, the manholes shall be raised to final grade by using the necessary sized grade rings and plywood shall be removed prior to occupancy.

E. Access To Manhole

1. All sewer manholes shall be designed and constructed with direct access to them, in the form of pavement, turf block, or as otherwise accepted by the District.

F. Drop Manholes

1. Internal drop manholes are not permitted

2. External drop manholes are allowed only at the District's discretion.

G. Cleanouts: Cleanouts are not permitted. All sewer mains shall terminate at a manhole.

1.04 HOUSE LATERALS

A. All sewer laterals shall be located by the Applicant and shown (with stationing) on the improvement plans.

B. House connections shall be constructed to the property line. There shall be one house sewer lateral constructed for each individually owned dwelling unit and it shall have a minimum diameter of 4 inches.

C. Sewer laterals shall not be connected at manholes.

D. No wye for sewer house connection branch shall be placed closer than 5 feet downstream of the centerline of any structure.

E. Laterals shall be installed after mass grading is finished and before other utilities are installed.

F. The Contractor shall certify the elevation of the house lateral and connection point.

G. The technical specifications for sewer laterals shall be the minimum set of requirements that a customer shall meet in order to connect to the MNWD sewer system.

H. The District shall be notified in advance of, and be present to inspect, all work on wyes and laterals in the vicinity of sewer mains.

I. Sewer laterals shall be the sole ownership and responsibility of the customer, up to and including the connecting wye, but excluding the main pipe barrel portion of the wye fitting.

J. 4-inch sewer house connections shall be laid to the grade as established by the Applicant so that the 4-inch house connection will have a minimum cover of 6 feet from the top of the curb to the top of the pipe.

K. Townhouses and Condominium Laterals

1. For buildings containing two to four units, either one 4-inch diameter lateral to each unit or one 6-inch diameter or larger lateral to the building shall be used.

2. For buildings containing more than four units, either one 4-inch diameter lateral to each unit or one 8-inch diameter or larger lateral to the building shall be used.

3. A lateral shall serve only one building regardless of number of units per building.

1.05 PRETREATMENT

A. Industrial Treatment

1. Requirements for industrial pretreatment will be determined as a result of processing the Industrial Waste Questionnaire in Section 300.2.3.4 through the South Orange County Wastewater Authority (SOCWA) office. Design requirements will be dependent upon those industrial pretreatment requirements.

B. Grease Interceptors

1. Any food service establishment within the District shall be evaluated for the requirement to install grease interceptors, per District's Sewer System Management Plan, to protect the collections systems and treatment plants from fats, oils, and grease.
2. Determine size/volume of grease interceptors tanks per requirements of Uniform Plumbing Code. Indicate size/volume on plans.
3. Grease interceptors are to be installed on the sewer laterals from all restaurants and other commercial sewer connections as designated by the District.
4. The technical specifications for grease interceptors shall be the minimum set of requirements that a customer shall meet in order to connect to the District's sewer system.
5. Grease interceptors are the sole ownership and responsibility of the customer.
6. The grease interceptor shall be located on private commercial sewer laterals upstream of the connection to the District's sewer main.
7. The interceptor shall be located where it is easily accessible for inspection, cleaning, and removal of intercepted grease.
8. It will be the responsibility of the owner of each facility to maintain proper operating order of the interceptor unit and to remove accumulated grease at suitable intervals to avoid excessive grease buildup or odors in the unit. The District will periodically inspect the interceptor. The Applicant shall follow guidelines as provided by District staff.

C. Clarifiers / Sand Interceptors

1. Clarifiers, sand interceptors, and/or hydrocarbon inlet filters shall be installed in areas which will produce petroleum products (e.g. mechanic shops, parking structures, car washes) at the direction of the District.
2. Installation of non-recirculating potable water systems is prohibited in commercial conveyor car wash and new commercial laundry systems.
3. Every sump or clarifier should be pumped out in full, cleaned, and checked for needed repairs at least annually. Any sump or clarifier should be pumped out in full and cleaned immediately if solids in any chamber exceed 25% of that chamber's capacity. All waste and repair manifests should be maintained for three years. If a sump or clarifier is overflowing, all flows to the sump or clarifier should be immediately pumped out in full, cleaned, and repaired before being placed back in service.

D. Trash Enclosures

1. Floor drains connected to sanitary sewer shall be protected from storm water entering the drains. Any drain in a trash enclosure or floor drain entering the sanitary sewer must have the following:
 - a. Filtered catch basin to capture any sediment, debris, trash, oil, and grease to prevent it from entering the sanitary sewer system
 - b. Roof to prevent storm water from entering the sanitary sewer system
 - c. Designed finished grades to divert sheeting water flow away from the drain

1.06 STANDARD SEWER NOTES

- A. Include all General Construction Notes and General Sewer Notes, as listed in the Standard Drawings, on all facility improvement plans or wastewater system construction plans.

END OF SECTION

Section IV

Standard Technical Specifications

**TABLE OF CONTENTS
TECHNICAL SPECIFICATIONS**

<u>Section</u>	<u>Description</u>
01025	Measurement and Payment
01045	Existing Facilities
01298	Schedule of Values
01310	Construction Project Schedules
01330	Submittal Procedures
01350	Project Asset Register
01550	Bypass Pumping
01615	Facility Identification
01630	Product Substitution Procedures
01650	Product Delivery, Storage, and Handling Requirements
01731	Equipment Operation and Maintenance Manuals
01780	Demonstration and Training
01910	Startup Testing and Commissioning
02200	Earthwork
02223	Trenching, Backfilling, and Compacting
03300	Concrete
03461	Precast Reinforced Concrete Manholes
03462	Precast Concrete Vaults
03463	Grease Interceptors
09810	Epoxy Coating for Sewer Manhole Rehabilitation
09900	Painting and Coating
13110	Dissimilar Metal Connections
13121	Corrosion Protection
15000	Pipe Supports
15041	Chlorination of Potable Water Mains and Services for Disinfection
15042	Hydrostatic Testing of Pressure Pipelines
15043	Testing of Non-Pressure Sewer Pipelines and Manholes
15050	Hot Tap Connections
15056	Ductile-Iron Pipe and Fittings
15057	Copper, Brass, and Bronze Pipe Fittings and Appurtenances
15064	PVC Pressure Distribution Pipe
15066	Gravity Sewer Pipelines
15068	Sewer Laterals
15072	Disposal of Asbestos Cement Pipe
15089	Air Valves
15100	Manual Valves
15112	Backflow Preventers
15139	Fire Hydrants
15150	Meters
15151	Potable Water, Recycled Water, and Wastewater Facilities Identification
15162	Pipe Couplings and Adapters
15170	Wall and Slab Penetrations
15300	Automatic Control Valves

<u>Section</u>	<u>Description</u>
16010	Electrical General Provisions
16050	Basic Materials and Methods
16060	Grounding and Bonding
16075	Electrical ID Nameplates and Warning Signs
16080	Electrical Testing
16120	Conductors and Cables
16130	Raceway Systems and Pull Boxes
16160	Panelboards
16290	Power Monitor
16419	Variable Frequency Drives
16431	Electrical System Analyses and Measurements
16441	Meter and Main Disconnect
16480	Low-Voltage Motor Control Center
16491	Automatic Transfer Switch
16500	Lighting

SECTION 01025

MEASUREMENT AND PAYMENT

PART 1 GENERAL

1.01 SUBMITTALS

- A. Schedule of Values

1.02 PAYMENT

- A. Payment for Unit Price Items

- 1. Payment for a unit price bid item shall be based upon the amount shown in the bid schedule multiplied by the total quantity measurement of the item and shall be full compensation for furnishing all supervision, planning, design, design engineering fees, labor, transportation, materials, equipment, tools and appurtenances required for construction of the item complete in place in accordance with the Plans and Specifications.

- B. Payment for Lump Sum Items

- 1. Payment for lump sum bid items shall be based upon the amount shown in the bid schedule and shall be full compensation for furnishing all supervision, planning, design, design engineering fees, labor, transportation, materials, equipment, tools and appurtenances required for construction of the unit of work complete in place in accordance with the Plans and Specifications.
- 2. Provide schedule of values for lump sum items as required by the District.

- C. Work Not Listed in the Bid Schedule

- 1. Costs for related work and appurtenances which are required and/or implied by the General Provisions, Technical Specifications, Special Provisions and Plans and are not listed as separate bid items, but are necessary to complete the project, shall be included in the appropriate bid item or items within the proposal.

1.03 MEASUREMENTS

- A. Measurement for unit price quantities shall be based upon the appropriate bid item in the proposal. The actual quantity of measurement shall be as constructed by the Contractor in place, in conformance with the Plans and Specifications.

- B. Linear Measurements: Measurement for pipelines and related facilities shall be made horizontally and/or vertically along the centerline of the pipeline and related facilities through tees, bends, valves, fittings and as shown on the Plans for its limits or as otherwise specified in the Special Provisions. Manholes and vaults shall be measured vertically from the lowest to the highest elevations and as shown on the Plans or as otherwise specified in the Special Provisions.

MOULTON NIGUEL WATER DISTRICT

- C. Area Measurements: Measurement for bid items involving area units shall be based upon the surface area measured in acres, square yards, square feet, or as indicated in the bid item.
- D. Volume Measurements: Measurement for bid items involving volume units shall be based upon the volume measured in cubic yards, tons, or as indicated in the bid item.
- E. Unit Measurements: Measurement for bid items involving units of the item shall be based upon the number of units counted as indicated in the bid item.
- F. Lump Sum Measurements: Measurement for a lump sum bid item shall be considered as a complete project or a portion of a project constituting a unit. The items to be included in the lump sum bid shall be as specified in the proposal bid item and/or the Standard or Special Provisions.

1.04 TESTING

- A. Party responsible for payment for testing is identified in individual sections under tests required. Where specifications are silent regarding responsible party paying for tests, costs of first tests will be paid by the District.
- B. If testing or inspection indicates failure of a material or procedure to meet Contract Document requirements, the District will backcharge the Contractor for retesting and re-inspection costs incurred by testing or inspection agency of the District’s choice.
- C. Additional tests and inspections not specified herein, but requested by the District, will be paid for by the District, unless result of such tests and inspections are found to not comply with Contract Documents. In which case, the District will pay all costs for initial testing as well as retesting and re-inspection and backcharge the Contractor for retesting and re-inspection.
- D. Costs for additional tests or inspections required because of change in materials being provided, or change of source of supply, shall be paid by the Contractor direct to the testing laboratory.
- E. Cost of testing, which is required solely for convenience of the Contractor’s scheduling and performance of Work, shall be borne by the Contractor.
- F. The Contractor shall pay all costs for correcting deficiencies.

PART 2 PRODUCTS (NOT USED)

PART 3 EXECUTION

3.01 SCOPE

- A. This section defines the bid items listed in the bid schedule and describes measurement and payment provisions for each of the bid items.
- B. Bid Item [#] – [To Be Determined by Engineer]

END OF SECTION

SECTION 01045

EXISTING FACILITIES

PART 1 GENERAL

1.01 SECTION INCLUDES

- A. Requirements for connection to, protection of, removal of, restoration of, and abandonment of existing District facilities

1.02 RELATED REQUIREMENTS

- A. Section 02223, Trenching, Backfilling, and Compacting
- B. Section 03300, Concrete
- C. Section 15041, Chlorination of Potable Water Mains and Services for Disinfection
- D. Section 15042, Hydrostatic Testing of Pressure Pipelines
- E. Section 15050, Hot Tap Connections
- F. Section 15072, Disposal of Asbestos Cement Pipe
- G. Section 15100, Manual Valves

1.03 CONDITION OF EXISTING FACILITIES

- A. The District cannot guarantee the condition, size, material, and location of existing facilities.
- B. Utilize a third party to provide a preconstruction video of existing facilities when determined necessary by the District.

1.04 LOCATION

- A. The Contractor shall be responsible for potholing and verifying in advance the locations of all existing pipelines as shown on the plans. Discrepancies shall be reported to the District prior to the fabrication of, or purchase of, material affected by the discrepancy. At a minimum, the Contractor shall pothole at all connections, crossings, and as otherwise directed by the District.

1.05 PROTECTION OF EXISTING UTILITIES AND FACILITIES

- A. The Contractor shall be responsible for the care and protection of all existing sewer pipe, water pipe, gas mains, culverts, power or communications lines, sidewalks, curbs, pavement, other hardscape, landscaping, or other facilities and structures that may be encountered in or near the area of the work.

- B. It shall be the duty of the Contractor to notify Underground Service Alert and each agency of jurisdiction and make arrangements for locating their facilities prior to beginning construction.
- C. In the event of damage to any existing facilities during the progress of the work and of the failure of the Contractor to exercise the proper precautions, the Contractor will pay for the cost of all repairs and protection to said facilities. The Contractor's work may be stopped by the District until repair operations are complete.

1.06 PROTECTION OF LANDSCAPING

- A. The Contractor shall be responsible for the protection of all the trees, shrubs, irrigation systems, fences, and other landscape items adjacent to or within the work area, unless they are directed to do otherwise on the plans.
- B. In the event of damage to landscape items, the Contractor shall replace the damaged items in a manner satisfactory to the District and the owner, or pay damages to the owner as directed by the District. The decision to replace or pay damages will be determined by the District and the owner of the damaged facilities.
- C. When the proposed pipeline is to be within planted or other improved areas in public or private easements, the Contractor shall restore such areas to the original condition after completion of the work. This restoration shall include grading, a placement of 5 inches of topsoil, resodding, and replacement of all approved landscape items that were present prior to construction. Native topsoil shall be used when feasible.
- D. If the Contractor does not proceed with the restoration after completion of the work or does not complete the restoration in a satisfactory manner, the District reserves the right to have the work done and to charge the Contractor for the actual cost of the restoration including all labor, material, and overhead required for restoration.

1.07 PERMITS

- A. All work shall conform to the specifications and requirements of the State of California Department of Transportation, the Orange County Public Works, the city having jurisdiction, or the other affected agencies involved. The Contractor shall keep a copy of all the required permits in the job site and comply with all the terms and conditions of said permits.

PART 2 PRODUCTS

2.01 GENERAL

- A. All materials used in making the connection or removing the facility from service shall conform to the applicable sections of these specifications.

2.02 GROUT

- A. Grout shall consist of Portland cement and water or of Portland cement, sand, and water; and all grout mixtures shall contain 2% of bentonite by weight of the cement. Grout shall be a pump mix with a minimum of 1-1/2 sacks cement (141 lbs) per cubic yard.

- B. Portland cement, water and sand shall conform to the applicable requirements of Section 03300, except that sand to be used shall be of such fineness that 100% will pass a standard 8-mesh sieve and at least 45%, by weight, will pass a standard 40-mesh sieve.

2.03 CONCRETE

- A. Concrete used for the replacement of damaged or removed facilities shall be in accordance with Section 03300 and shall match the mix design of the existing facility and per the requirement of the jurisdictional agency. If mix design of existing facility is unknown, assume Class B.

PART 3 EXECUTION

3.01 CONNECTION TO EXISTING FACILITIES

- A. All connections shall be made by the Contractor unless shown otherwise on the plans or specified herein.
- B. The Contractor shall notify the District a minimum of five working days before the time of any proposed shutdown of existing mains or services. The District may postpone or reschedule any shutdown operation if for any reason they feel that the Contractor is improperly prepared with competent personnel, equipment, or materials to proceed with the connection work.
- C. Connections shall be made only in the presence of the District, and no connection work shall proceed until the District has given notice to proceed. If progress is inadequate during the connection operations to complete the connection in the time specified, the District shall order necessary corrective measures. All costs for corrective measures shall be paid by the Contractor.
- D. The Contractor shall furnish all pipe and materials including furnishing all labor and equipment necessary to make the connections, all required excavation, backfill, pavement replacement, lights, and barricades, and may be required to include a water truck, high line hose, and fittings as part of this equipment for making the connections. The Contractor is advised that, due to the nature and condition of existing facilities, it is typically necessary for the District to make multiple attempts in order to isolate for making connections. The Contractor shall make the necessary arrangements to account for the time required for shutdown until work can proceed on affected facilities.
- E. The Contractor will de-water existing mains, as required, in the presence of the District. Any water generated from dewatering operations shall be discharged to the nearest sanitary sewer, unless otherwise directed by the District. If no sanitary sewer is present in the vicinity of the work and discharge to storm drain is not allowed by the agency having jurisdiction, the District may require the use of a water truck to transport the water to a suitable location.
- F. Connections shall be made with as little change as possible in the grade of the new main. Where the connection creates a high or low spot in the line, a standard air valve or blow off assembly shall be installed as directed by the District.

- G. Where connections are made to existing valves, the Contractor shall furnish and install all temporary blocking, steel clamps, shackles, and anchors as required by the District, and they shall replace the valve riser box and cover and adjust the valve cover to the proper grade in accordance with these specifications. The District will operate all existing valves. All valves, existing or newly installed, shall be readily accessible at all times to the District for emergency operation.
- H. New pipelines shall not be connected to existing facilities until the new pipelines have been successfully tested and disinfected by the Contractor and accepted by the District.
- I. Tapping connection can be made to the existing system while it is either in service or shut down depending on the District's prior direction. Tapping connection shall be made per Section 15050 when the existing system is required to be maintained in service during connection.
- J. Size-on-size connections shall be made using a cut-in tee. Size-on size connections may be made using a hot tap only under exceptional circumstances and with special permission from the District.
- K. All saddle connections into existing sewerlines shall be made with a wye saddle. Saddles shall conform to the applicable provisions of the section for the existing sewerline material.

3.02 REMOVAL FROM SERVICE OF EXISTING MAINS AND APPURTENANCES

- A. Existing mains and appurtenances shall be removed from service at the locations shown on the plans or as directed by the District.
- B. Existing pipe and appurtenances removed from the ground will require backfill and repair of surface in accordance with Section 02223.
- C. Removed pipe and appurtenances shall be temporarily stockpiled on the job in a location that will not disrupt traffic or be a safety hazard, disposed of in a proper manner (as determined by the District). The Contractor shall remove and dispose of all removed pipe at his own expense.
- D. Before excavating for installing mains that are to replace existing pipes and/or services, the Contractor shall make proper provisions for the maintenance and continuation of service as directed by the District unless otherwise specified.
- E. Water services shall be abandoned by one of the following methods, or as directed by the District:
 - 1. The service line shall be cut 6 inch from the corporation stop and the corporation stop shall be closed and capped.
 - 2. Pipeline shall be shut down, corporation stop removed from the saddle, and service saddle plugged. The abandoned service line shall be removed at the request of the District.
- F. Asbestos Cement Pipe (ACP) shall be cut, removed and disposed of in a proper manner. The Contractor will be responsible for the proper manifesting of the ACP at an authorized disposal site. See Section 15072 for additional requirements.

- G. Pipe shall be abandoned in place only with special permission from the District. Abandoned pipe shall be filled with grout. Pipe to be abandoned shall be exposed or tapped at the far end (or ends) from where the grout is being introduced into the pipe to allow for visual verification by the District that the grout has reached the end of the pipe. Any differences require the Contractor to submit a plan for District acceptance.

3.03 CUTTING AND RESTORING STREET SURFACING

- A. In cutting or breaking up street surfacing, the Contractor shall not use equipment that will damage adjacent pavement.
- B. All asphalt and/or Portland cement concrete surfaces shall be scored with sawing equipment of a type meeting the approval of the city or agency having jurisdiction; providing however, that any cement concrete base under an asphaltic mix surface will not be required to be scored by sawing. Existing paving surfaces shall be saw cut back beyond the edges of the trenches to form neat square cuts before repaving is commenced.
- C. Pavement, sidewalks, curbs, or gutters removed or destroyed in connection with performance of the work shall be saw cut to the nearest score marks, if any, and shall be replaced with pavement sidewalks, curbs, or gutters of the same kind, or better, by the Contractor in accordance with the latest specifications, rules, and regulations and subject to the inspection of the agency having jurisdiction over the street or highway.
- D. Aggregate base shall be placed beneath the restored pavement to the thickness required by the agency having jurisdiction.

END OF SECTION

SECTION 01298

SCHEDULE OF VALUES

PART 1 GENERAL

1.01 REQUIREMENTS

- A. Contractor shall submit a Schedule of Values for Owner's approval. The Schedule of Values is a detailed itemized breakdown of all lump sum bid items. Submit corrected Schedule of Values within ten (10) days of receiving Owner's reviewed Schedule of Values requiring correction.
- B. The Schedule of Values shall be used as a basis for determining progress payments on a lump sum contract or any designated lump sum bid item. The Schedule of Values shall be a schedule of cost loaded construction activities equal, in total, to the lump sum bid and shall be in such form and sufficient detail to correctly represent a reasonable apportionment of the lump sum. Prior to submitting a monthly payment request, the Contractor shall have submitted a detailed Schedule of Values and obtained approval from the Owner.
- C. Each lump sum bid item on the Bid Schedule(s), as set forth in the Contractor's Bid Proposal must be broken down separately. The breakdown of each lump sum bid item must cover the cost of construction required by the Contract Drawings and Specifications for that item. The sum of the values for the construction activities, within a bid item, must equal the total bid amount for that item. The breakdown shall include subcontract amounts, which shall not deviate from the amounts submitted in the Bid Proposal. The Contractor shall provide certification from the Subcontractors certifying the subcontract amounts.
- D. Each activity in the Schedule of Values shall delineate one construction activity. For example, the placement of concrete between construction joints, the construction of an electrical duct bank or pipeline between points A & B. The costing for each activity should include all costs for the labor and materials or equipment required to complete the activity. For example, concrete construction activities should include all costs for the forming, placing of reinforcement, placing concrete, and curing. The cost for pipeline construction activities should include materials, equipment and installation including pipeline supports or thrust blocks. The excavation and backfill for a pipeline or structure may be separate activities. The Bid Proposal breakdown shall include the itemized costs for facility startup and testing to be performed before the final project acceptance is made. No non-construction activity shall be cost loaded.
- E. Where Contract Documents require a CPM Construction Schedule, the Contractor shall use cost loaded construction activities from the Construction Schedule as a Schedule of Values. Each construction activity shall be encoded to its bid item and a sort provided for each bid item totaling the cost loaded amount. The total of the Cost Loaded amounts for each bid item shall equal the amount bid for that item.
- F. The total of the Schedule of Values shall equal the current Contract value at all times. At any time during the progress of the Contract Work, the Owner reserves the right to review the cost loading of the Schedules of Values and direct necessary revisions. When requested by the Owner, the Contractor shall provide all information necessary to substantiate the cost loading.

PART 2 PRODUCTS (NOT USED)

PART 3 EXECUTION

3.01 MOBILIZATION

- A. Contractor shall limit amounts included under mobilization to the following items (if required by the Contractor Documents):
 - 1. Moving onsite any equipment required for first month operations.
 - 2. Temporary construction power.
 - 3. Fire protection system.
 - 4. Construction water supply.
 - 5. Providing field office trailers.
 - 6. Providing onsite sanitary facilities.
 - 7. Providing potable water facilities as specified.
 - 8. Arranging for and erection of Contractor's work and storage yard.
 - 9. Contractor's bonds and insurance.
 - 10. Subcontractor bonds and insurance.
 - 11. Obtaining all required permits, licenses, and fees.
 - 12. Developing construction schedule and Schedule of Values.

3.02 EXAMPLE OF CATEGORIES REQUIRED FOR SCHEDULE OF VALUES

- A. The following is an example of categories required for the Schedule of Values. It represents the minimum level of detail required to quantify the scope of work. Contractor shall provide any necessary additional breakdown of any of the items listed below and Owner may also require additional breakdown of any and all items. Contractor shall verify all quantities and items of work prior to submittal.

ITEM NO.	DESCRIPTION	QTY.	UNIT	UNIT COST	TOTAL COST
1	Mobilization, Bonds, Insurance, Permits, Construction Schedule, and Schedule of Values		LS		\$ _____
2	Audio-Video Recording		LS		\$ _____
3	Equipment Items ⁽¹⁾				
	A. Materials		LS		\$ _____
	B. Installation		LS		\$ _____
	C. Testing		LS		\$ _____

MOULTON NIGUEL WATER DISTRICT

ITEM NO.	DESCRIPTION	QTY.	UNIT	UNIT COST	TOTAL COST
4	Site Work Activities ⁽¹⁾				
	A. Excavation		LS or CY		\$ _____
	B. Backfill		LS or CY		\$ _____
	C. Rough Grading		LS or CY		\$ _____
	D. Fine Grading		LS		\$ _____
	E. Import/Export		CY		\$ _____
	F. Dewatering		LS		\$ _____
	G. Concrete Slabs ⁽²⁾		CY		\$ _____
	H. Concrete Footings ⁽²⁾		CY		\$ _____
	I. Paving		SF		\$ _____
	J. Curbs/Curbs and Gutters ⁽²⁾		LF		\$ _____
	K. Guard Posts		EA		\$ _____
	L. Pre-Cast Vaults		LS or EA		\$ _____
	M. Fencing		LF		\$ _____
	N. Gates		LS		\$ _____
	O. Miscellaneous Concrete ⁽²⁾		CY or LF		\$ _____
5	Piping ⁽¹⁾				
	A. Materials (including Fittings)		LF		\$ _____
	B. Installation		LF		\$ _____
	C. Supports		EA		\$ _____
	D. Valves		EA		\$ _____
	E. Coatings		LS		\$ _____
	F. Testing		LS		\$ _____
6	Cast-in-Place Concrete Structures ⁽¹⁾				
	A. Site Preparation		LS		\$ _____

MOULTON NIGUEL WATER DISTRICT

ITEM NO.	DESCRIPTION	QTY.	UNIT	UNIT COST	TOTAL COST
	B. Demolition (if necessary)		LS		\$_____
	C. Excavation		LS or CY		\$_____
	D. Backfill		LS or CY		\$_____
	E. Dewatering		LS		\$_____
	F. Base Materials		LS or CY		\$_____
	G. Pump Can Footings ⁽²⁾		CY		\$_____
	H. Pump Can Walls ⁽²⁾		CY		\$_____
	I. Miscellaneous Concrete ⁽²⁾		CY		\$_____
	J. Finishing		LS		\$_____
7	Equipment Building				
	A. Site Preparation		LS		\$_____
	B. Excavation		LS or CY		\$_____
	C. Backfill		LS or CY		\$_____
	D. Concrete Foundation ⁽²⁾		CY		\$_____
	E. Concrete Slab ⁽²⁾		CY		\$_____
	F. Masonry Walls		SF		\$_____
	G. Structural Steel		LS		\$_____
	H. Built Up Roofing		LS		\$_____
8	Electrical/Instrumentation/ Lighting ⁽¹⁾				
	A. Electrical Service Panel/ Distribution Switchboard		LS		\$_____
	B. Automatic Transfer Switches		LS		\$_____
	C. Motor Control Centers		LS		\$_____
	E. Control Panels		LS or EA		\$_____
	F. Lighting Panels		LS or EA		\$_____
	G. Equipment Control Panels		LS or EA		\$_____

MOULTON NIGUEL WATER DISTRICT

ITEM NO.	DESCRIPTION	QTY.	UNIT	UNIT COST	TOTAL COST
	H. Conduit (Above Grade)		LS or LF		\$_____
	I. Conduit (Below Grade)		LS or LF		\$_____
	J. Conductors (Above Grade)		LS or LF		\$_____
	K. Conductors (Below Grade)		LS or LF		\$_____
	L. Pull Boxes		LS or EA		\$_____
	M. Junction Boxes		LS or EA		\$_____
	N. Short Circuit Coordination Study, Arc Flash		LS		\$_____
	O. Lighting		LS or EA		\$_____
	P. Emergency Standby Generator Terminal Box		LS		\$_____
	Q. Pressure Transducers		LS or EA		\$_____
	R. Meters		LS or EA		\$_____
	U. Other Instrumentation		LS		\$_____
	V. Security Systems		LS or EA		\$_____
9	Preparation of Operation & Maintenance Manuals		LS		\$_____
10	Equipment Startup and Performance Testing		LS		\$_____
11	Equipment Training		LS		\$_____
12	Performance of Live Operational Testing		LS		\$_____
TOTAL (MUST EQUAL CONTRACT AMOUNT)					\$_____

**DO NOT SUBMIT THE SCHEDULE OF VALUES
WITH YOUR BID PROPOSAL PACKAGE**

Notes:

- (1) These work and equipment items shall be broken down by area or facility.
- (2) Concrete placements shall be broken down into forming, placement of rebar, placement of concrete, and curing (i.e. successful cylinder breaks). If Schedule of Values does not break down concrete placements into these subcategories, payment will not be made until concrete placements are complete.

END OF SECTION

SECTION 01310

CONSTRUCTION PROJECT SCHEDULES

PART 1 – GENERAL

1.01 SUMMARY

- A. This section covers the preparation and submittal of the project schedules.
- B. Project schedules comprised of work activities and logical predecessor/successor ties shall be used to control the Work and to provide a definitive basis for determining project progress. The Project Schedule shall be prepared, maintained, and updated by the Contractor and historical dates agreed monthly with District. The schedule shall be the Contractor’s working schedules and shall be used to plan, organize and execute the Work, record and report actual performance and progress, and show how Contractor plans to complete all remaining Work as of the end of each progress report period.

1.02 RELATED SECTIONS

- A. The WORK of the following Sections applies to the WORK of this Section. Other Sections of the Specifications, not referenced below, shall also apply to the extent required for proper performance of this WORK.
 - 1. Section 01025 Measurement and Payment
 - 2. Section 01298 Schedule of Values
 - 3. Section 01300 Submittal Procedures
 - 4. Section 01910 Startup Testing and Commissioning

1.03 DEFINITION

- A. The following narratives describe the types of schedules the Contractor shall provide during the course of construction, further clarified in this section.
 - 1. Baseline Project Schedule: The initial schedule submitted at the beginning of the project, reviewed by the District.
 - 2. Progress Schedules: On a monthly basis the Contractor shall produce an updated Project Schedule for review by the District. This schedule shall reflect the prior month’s physically completed work and the impact to the successive activities. This schedule shall also be included with monthly progress payments.
 - 3. Look Ahead Schedules: During weekly progress meetings the Contractor shall produce a 3-week look ahead schedule to show the work across a 4 week period as follows; show physical work completed during the prior week, the work scheduled for the current week, and the following 2 weeks of work activities. Contractor shall produce updated look-ahead schedules upon request by the District throughout the project, not to exceed 1 update per week.
 - 4. Recovery Schedule: A schedule the Contractor provides in the event of a loss of time and a potential impact to the critical path schedule.
 - 5. Float: The amount of time between the completion of construction activities and the contract end date.

6. Notice to Proceed: Authorization for Contractor to begin work and official start date of the Contract.

PART 2 – PRODUCTS (NOT USED)

PART 3 – EXECUTION

3.01 GENERAL

- A. The Project Schedule shall comprise all the detailed construction-related activities using the critical path method (CPM). The Project Schedule shall provide sufficient detail and clarity to reflect the intricacies and interdependencies of activities so Contractor can plan, schedule, monitor, control and report on the progress of his work. In addition, it shall provide District a tool to monitor and follow the progress for all phases of the Work.
- B. The start date for the Project Schedule shall be the date at which the District issues the Notice to Proceed (NTP).

3.02 PRE-CONSTRUCTION SCHEDULING CONFERENCE

- A. The Contractor shall conduct a pre-construction scheduling conference with the District to review requirements for the schedules including Schedule of Values, cost-loading and schedule configuration. The conference shall be conducted prior to the District issuing the NTP and before the preconstruction meeting.
- B. At this meeting, Contractor shall explain in detail the procedure to be used to develop the schedule activity cost-loading or Schedule of Values and cash flow. This procedure is subject to the review and acceptance of the District.

3.03 SCHEDULE SUBMITTAL FORMAT

- A. Contractor shall submit all schedules in PDF format and also provide a copy of the native software file. A cover letter shall accompany the submittal and shall include a description of the Contract milestones, approach for construction activities during the period of the draft Baseline Project Schedule, a description of the project’s critical path, identification of critical long-lead submittals, planned outages, and a summary of issues that are critical to the schedule or may impact the critical path and the contractor’s mitigation measures to prevent delay. The narrative shall also incorporate activity codes, calendars, weather days, milestone constraints, and work breakdown structure in accordance with the requirements specified herein.

3.04 BASELINE PROJECT SCHEDULE

- A. The Baseline Project Schedule comprises all the construction-related activities for the Work and shall show the order in which Contractor proposes to carry out the work. All activities shall include logic ties and be set to auto-schedule and allow the logic to update the schedule dates; manually scheduled activities shall not be allowed except for NTP or specific cases where approved by the District. Contractor shall include milestones, coordination necessitated by limited access and available work areas, and the availability and use of manpower, material and equipment. Contractor shall use the baseline schedule to plan, schedule and coordinate the Work including activities of subcontractors, equipment vendors, and suppliers.

- B. The Baseline Project Schedule shall be to the level of detail acceptable to District, and shall include the following:
1. Organization and structural breakdown of the Project;
 2. Milestones and completion dates;
 3. Type of work to be performed and the labor trades involved;
 4. Purchase, manufacture and delivery activities for major materials and equipment;
 5. Preparation, submittal, and acceptance of shop drawings and material samples;
 6. Deliveries of District-furnished equipment and/or materials;
 7. Acceptances required by regulatory agencies and/or other third parties;
 8. Assignment of responsibility for each activity;
 9. Access requirements to work areas;
 10. Identification of interfaces and dependencies with preceding, concurrent and follow-on contractors;
 11. Tests, submittal of test reports and acceptance of test results;
 12. Preparation, submittal, and acceptance of startup schedule and plan.
 13. Planning for phased or total acceptance by District; including start up and commissioning;
 14. Identification of any manpower, material and equipment restrictions;
 15. Sequence of construction to maintain facility operations;
 16. Planned outages.
- C. The activities included in the Project Schedule shall be defined in work days. Time based and non-construction activities, such as concrete curing and disinfection, shall be defined in calendar days. Durations shall be based on the labor (crafts), equipment, and materials required to perform each activity on a normal workday basis. Activity durations shall be 20 working days or less except in the case of non-construction activities such as procurement of materials, delivery of equipment, and concrete curing. All durations shall be the result of definitive manpower and resource planning by Contractor to perform the Work, in consideration of contractually defined on-site work conditions and Contractor's planned means and methods.

3.05 MONTHLY PROGRESS SCHEDULES

- A. Monthly Progress Schedules shall be submitted for the duration of the Contract on a date agreed to by District and Contractor. If monthly Project Schedules are not submitted by the due date, progress payments will be withheld until the required information is submitted.
- B. The updated schedule shall be reviewed each month in a meeting with District to verify the following, at minimum, is included:
1. Narrative report summarizing the milestones, critical path, project approach including phasing or use of crews, significant submittal and fabrication items, coordination or interface requirements, District-furnished items, and list of subcontractors and vendors.
 2. Actual start dates,
 3. Actual completion dates,
 4. Activity percent completion,

5. Revised logic (as-built and project) and changes in activity durations, cost assigned,
 6. Impacts due to change orders, if any,
 7. Revisions due to extension of time.
- C. Prior to each meeting, Contractor shall prepare a complete and accurate report of current procurement and construction progress through the end of the update period, and a depiction of how Contractor plans to continue the Work to meet all contract completion dates.
- D. For major schedule changes that cannot be agreed to during an updating meeting, Contractor shall submit the proposed changes for the District's acceptance prior to inserting such changes into the project schedule.
- E. The monthly Progress Schedule shall be presented in the following layouts:
1. Summary Schedule: one page milestone and summary schedule, sorted by early-start, early-finish;
 2. Detailed Project Schedule: organized by Work Breakdown Structure (WBS) or area of work; sorted by total Float, early-start, early-finish;
 3. Critical Path Schedule: sorted based on the total Float, early-start, early-finish;

3.06 ELECTRONIC PROJECT SCHEDULE FORMAT AND REPORTING

- A. The Project Schedule shall be created using Microsoft Project, Primavera P6, or other scheduling software accepted by the District. Contractor shall use District's file-naming format throughout the project.
1. Electronic schedule files shall be saved with .MPP, .XML, or .XER file extensions.
 2. The data date for schedule calculation in the baseline Project Schedule shall be set as the date of the Notice to Proceed unless otherwise specified by District.
 3. The data date for schedule calculation in the Monthly Progress Schedules shall be the first day of the month.

3.07 COST-LOADING

- A. Except for manufacturer lead-time, each Project Schedule activity that has an actual cost shall have a cost value assigned to it. Equipment or material delivery activities bearing cost shall be separate activities. Each activity's assigned cost shall consist of all costs associated with that activity including all project management, superintendence, overhead and profit costs. The sum of all activity costs shall be equal to the current Contract Price at all times, including approved change orders. Contractor shall certify that the costs are not unbalanced and that the value assigned to each activity represents Contractor's total cost to perform that activity.
- B. If District determines cost data does not meet the requirements for a balanced bid breakdown, Contractor shall submit documentation substantiating any cost allocation questioned. Cost allocations will be considered unbalanced if an activity on the Project Schedule has been assigned a disproportionate allocation of direct costs, overhead and profit. If documentation of the cost data does not, in the opinion of District substantiate cost allocations, the Project Schedule will be returned to Contractor for correction.
- C. Unit Price items required to be paid on a unit cost basis as identified in the Bid and the Measurement and Payment section shall be incorporated into the Project Schedule and measured and updated as specified herein and as specified in the Measurement and Payment section.

- D. Cost-loaded data shall be the basis for monthly payment applications and shall be included with monthly updates of the Project Schedule.

3.08 COORDINATING PROJECT SCHEDULE WITH OTHER CONTRACT SCHEDULES

- A. Where work is to be performed under this Contract concurrently with or contingent upon work performed on the same facilities or area under other contracts, the Project Schedule shall be coordinated with the schedules of the other contracts. District will provide the schedules of other contracts for preparation and updating of the Project Schedule. Contractor shall revise the Project Schedule as required by changes in schedules of other contracts.
- B. In case of interference between the operations of different contractors, District will determine the work priority of each contractor and the sequence of work necessary to expedite the completion of the entire project. In all such cases, the decision of District shall be accepted as final.

3.09 REVIEW PROCESS

- A. District will review Contractor's preliminary Baseline Project Schedule submittal within 15 calendar days after receipt of all required information.
- B. At the request of District, Contractor shall participate in any meetings necessary to reach a mutual agreement and acceptance of the Baseline Project Schedule.
- C. Schedules shall show contract completion of the Work on the anticipated Work completion date, not the Contract completion date.
- D. In no event shall acceptance of the Project Schedule be a basis for a claim for delay against District by Contractor. A Project Schedule containing activities with negative Float or that extend beyond the date that the Work is completed and ready for final payment will not be acceptable.
- E. Review of the Project Schedule by District does not relieve Contractor of responsibility for accomplishing the Work by the Contract completion date. Omissions and errors in the Project Schedule shall not relieve Contractor of obligations under the Contract. Review by District in no way makes District responsible for the Project Schedule's success or liable for time or cost overruns. District hereby disclaim any obligation or liability by reason of review of the Project Schedule by District.

3.10 RESPONSIBILITY FOR SCHEDULE COMPLIANCE

- A. Whenever it becomes apparent from the current Project Schedule that the critical path is delayed and the contract completion date will not be met, Contractor shall mitigate the delay by taking some or all of the following actions at no additional cost to District.
 - 1. Increase construction manpower in such quantities and crafts as will bring the project back on schedule within the completion dates and milestones.
 - 2. Increase the number of working hours per shift, shifts per day, working days per week, and the amount of construction equipment, or any combination of the foregoing, to substantially eliminate the backlog of work.
 - 3. Re-schedule activities to achieve maximum practical concurrence of activities and to comply with the schedule date(s).

- B. Within ten calendar days of District’s request, Contractor shall submit a recovery schedule and written statement of the steps intended to remove or arrest the delay to the critical path in the schedule. If Contractor fails to submit the required information or should fail to take measures acceptable to District, District concurrence may direct Contractor to increase man-power, equipment and scheduled work hours to remove or arrest the delay to the critical path and Contractor shall promptly provide such level of effort at no additional cost to District.
- C. In the event Contractor fails to follow the updated or revised recovery schedule, District may elect to withhold progress payments until Contractor complies with the revised schedule.

3.11 AS-BUILT SCHEDULE

- A. As a condition precedent to release of final payment, the last update to the Project Schedule submitted shall be identified by Contractor as the “As-Built Schedule”. The “As-Built Schedule” shall reflect the exact manner in which the project was actually constructed (including actual start and completion dates, activities, sequences, and logic) and shall be signed and certified by Contractor’s project manager.

3.12 ACTIVITY RELATIONSHIPS

- A. Relationships (logic ties) between activities shall be identified with the following information:
 - 1. Predecessor and successor activity ID.
 - 2. Relationship types:
 - a. FS – Finish to start
 - b. SS – Start to start
 - c. FF – Finish to finish
 - d. SF – Start to finish – This relationship is not allowed, unless authorized by District.

3.13 FLOAT

- A. The Contractor shall provide accurate estimates of the completion dates and shall indicate the amount of float between the construction completion and contract end dates. Schedules shall not show any negative float. Any float shown on the schedule will belong to the project.

3.14 FLOAT SUPPRESSION

- A. Contractor shall not use Float suppression techniques, including preferential sequencing (arranging critical path through activities more susceptible to District caused delay); lag logic restraints; zero total or free Float constraints; extended activity times; or imposing constraint dates other than as required by the Contract.

3.15 MANDATORY MILESTONES

- A. The Contract duration shall be equal to the time period between the NTP and the completion of the Work in readiness for final payment. The following milestones are mandatory.
 - 1. Notice to Proceed
 - 2. Milestones, if any, as indicated in Contractor’s Bid
 - 3. Substantial Completion as indicated in Contractor’s Bid
 - 4. Completion and readiness for final payment, as indicated in Contractor’s Bid

MOULTON NIGUEL WATER DISTRICT

- B. The following additional milestones are to be considered and incorporated into the Project Schedule in accordance with the Contract, if applicable.
 - 1. Permit constraints
 - 2. Facility shut down or outage milestone requirements
 - 3. Applicable phasing milestones
 - 4. Other milestones deemed appropriate by District

3.16 WEATHER DAYS

- A. Weather days shall be added to the Baseline Project Schedule and Progress Schedules as a separate identifiable activity. Weather days shall be added when inclement weather days are experienced and agreed upon by the District.

END OF SECTION

SECTION 01330

SUBMITTAL PROCEDURES

PART 1 GENERAL

1.01 SECTION INCLUDES

- A. General procedures and requirements for submittals

1.02 SUBMITTALS

- A. Submit two hard copies and an electronic copy of submittals unless otherwise stated. Only an electronic copy will be returned to the Contractor.
- B. Number submittals using numbering system as directed by the District.
- C. Shop Drawing Transmittal Form. The form included at the end of this section shall be used unless otherwise directed by the District. Submit a separate form for each submittal number. Submittals without a completed the Contractor's Transmittal Form attached to each copy of each submittal listed in Schedule of Submittals will be returned without review and stamped "REJECTED/RESUBMIT AS SPECIFIED."
- D. Contractor shall provide a copy of the applicable specification section and/or drawing with each submittal and shall check-off each paragraph, detail, etc. to note compliance or exception. Exceptions and departures from Contract Documents shall be clearly noted, along with brief justification for each exception or departure. The District's review or acceptance of submittals shall only constitute acceptance of the following:
 - 1. Portions of submittal in compliance with Contract Documents
 - 2. Exceptions or departures expressly noted on the Contractor's submittal as "exceptions" or "departures" and accepted in writing by the District
 - 3. Exceptions or departures that the District may by chance discover, acknowledge, and accept in writing, in the District's response to said submittal
- E. In the event a submittal's exception or departure from Contract Documents is neither noted by the Contractor on their submittal nor acknowledged and expressly accepted by the District, the Contract shall remain unchanged. The District's failure to discover all exceptions and departures in submittals whether intentional or unintentional on the Contractor's part shall in no way relieve the Contractor of any Contract responsibilities.
- F. Stock or standard drawings will not be accepted for review unless full identification and supplementary information is shown thereon in ink or typewritten form.
- G. Review of submittals shall proceed as follows:
 - 1. Submit specified quantity of complete submittals together with the Contractor's submittal forms to the District for review. Fold submittals to approximately 8 ½ inches by 11-inches.

MOULTON NIGUEL WATER DISTRICT

2. Submittals will be stamped "ACCEPTED", "ACCEPTED AS NOTED", "SUBMIT ITEMS AS NOTED", "RECEIVED PURSUANT TO CONTRACT REQUIREMENTS", "REVISE AND RESUBMIT", "REJECTED", "RECEIVED FOR INFORMATION ONLY," or "OTHER: ". Three copies with letter of transmittal will be returned to the Contractor.
 3. If drawing or data is returned stamped "ACCEPTED" or "ACCEPTED AS NOTED", no further resubmittals will be required for that item.
 4. If drawing or data is stamped "REVISE AND RESUBMIT" or "REJECTED", make necessary corrections and resubmit documents as required in Instruction 1. The Contractor's submittal form transmitting revised documents shall show that documents comprise a resubmittal. Revisions and resubmittals shall be numbered as Revision #1, Revision #2, or as appropriate.
 5. If changes other than those noted by the District are made on a submittal before resubmittal, note such changes on resubmittal.
 6. All resubmittals shall be complete, containing all previously submitted information that did not change along with the revised information. Partial resubmittals will be returned without review.
 7. Revise and resubmit submittals as required, until confirmation of compliance with plans and specifications is obtained.
 8. Drawings or data stamped "SUBMIT ITEMS AS NOTED" means that the District does not take exception to the information submitted but requires additional information. The additional information shall be provided as part of a complete resubmittal.
 9. Drawings or data stamped "RECEIVED PURSUANT TO CONTRACT REQUIREMENTS" means that the District acknowledges that the information has been submitted pursuant to contract requirements but the District takes no action other than to receive it.
 10. Drawings or data stamped "RECEIVED FOR INFORMATION ONLY" means that the District acknowledges that the information has been submitted for the District's reference but the District takes no action other than to receive it.
 11. The District may elect to take an action on a submittal other than those indicated above by stamping the drawings or data with "OTHER" and writing-in an action.
- H. Costs incurred by the District for second and subsequent resubmittals will be deducted from payment due to the Contractor.
- I. Allow no less than 30 calendar days for review and response to submittals. Review may be delayed if contingent on receipt of other submittals. Upon timely written request by the Contractor, the District will make reasonable efforts to shorten review periods which may fall on the Contractor's critical path.
- J. Correct and resubmit rejected submittals within 14 calendar days.
- K. Do not order products or begin work described in required submittals until such submittals have been reviewed and returned by the District stamped "ACCEPTED" or "ACCEPTED AS NOTED". The Contractor's acceptance of delivery of products prior to receipt of the District's satisfactory return of applicable submittals shall be at the Contractor's risk.

- L. Review of submittals by the District shall extend solely to the general type and layout of the Work and shall not be construed as relieving the Contractor of full responsibility for adequacy and accuracy of submitted designs and details shown in submittals.

1.03 INITIAL SUBMITTAL

- A. Submit the following within 48 hours after contract execution:
 - 1. Names and addresses of manufacturers furnishing products valued greater than either 4 percent of contract value or \$40,000, whichever is less. State locations of shops at which manufacture will take place. State whether products are already designed or in production. Include a brief description of products proposed, including sizes and catalog numbers.
 - 2. Letter addressed to the District identifying Contractor's superintendent, safety officer, and traffic control coordinator, including emergency telephone numbers and signature authorization, and listing names, addresses and telephone numbers for subcontractors.

1.04 SUBMITTALS ON DISTRICT'S REQUEST – SUPPLEMENTAL INFORMATION

- A. Detailed construction schedule updates shall be submitted, with monthly pay requests to describe scheduling of elements of construction requiring the District's or the Contractor's coordination with public, or other private parties or public agencies.
- B. Supplemental information will be requested for "accepted equals" and may be requested when there is a question whether a manufacturer's product conforms to Contract Documents. The District reserves the right to require submittal of supplemental information as described herein before acceptance of product.
- C. Certification of compliance with listed reference standards shall be submitted by manufacturers upon the District's request. Failure of the District to request certification of compliance shall not serve as waiver of the Contractor's duty to comply with reference standards.
- D. Transcripts of results of acceptance tests, performed at point of manufacture of products furnished, shall be submitted by manufacturers upon the District's request.
- E. Samples shall be submitted upon the District's request.
- F. Names and addresses of nearest local service representatives maintaining technical service, personnel, and complete inventory of spare parts and accessories shall be submitted upon the District's request.
- G. List of three installations in which products are now in regular operation, which are comparable in size, capacity and rating with those required in the Contract Documents shall be submitted upon the District's request. Include listing of size, capacity, or rating of each installation. Include name and telephone number of at least one reference responsible for operations at each installation whom the District may contact.

1.05 PROGRESS REPORTS

- A. Daily log shall be submitted by the Contractor's superintendent on a one page form provided by the District. These logs shall be detailed with activities that took place during each day. Submit logs daily to the District by the end of following workday.

- B. Schedule updates shall be submitted with monthly pay requests. If Work falls behind schedule, monthly pay requests shall include revised schedules to demonstrate how the Contractor intends to bring work back on schedule.
- C. Record drawings, consisting of one set of full size annotated blueline plans and other drawings forming a part of contract, showing installed locations of improvements and all changes made during construction shall be available to the District for inspection throughout the project. Record all deviations from Contract Documents, including accepted change orders, using additional sketches or ink revisions, immediately after installing each portion of the Work. Show locations of underground piping, conduit, sensor lines, valves, capped ends, branch fittings, pull boxes and other Work. Keep one current record copy of Contract Documents, addenda, supplementary drawings, working drawings, change orders and clarifications at site and in good order. Report changes and deviations promptly to the District.
- D. Partial payment requests may be withheld if daily logs, schedule updates, or record drawings are damaged, lost or not kept current to satisfaction of the District.

1.06 CONTRACTOR’S NOTICE OF PENDING DELAY CLAIM

- A. In the event a delay claim is foreseen by the Contractor, the Contractor shall immediately notify the District in writing. Following said notice, the Contractor shall have no more than seven calendar days to furnish follow-up information as is required by the District to allow the District to act judiciously to minimize losses. At a minimum, said information shall consist of a letter identifying and substantiating the cost of the expected claim per day of delay accompanied by a schedule showing any available float and delay impact on overall schedule.

1.07 SHOP DRAWINGS AND PRODUCT DATA

- A. Shop drawings shall be defined as job-specific drawings prepared to scale wherever possible and shall include the project name and contract number on the shop drawing.
- B. Except where preparation of a submittal is contingent upon acceptance of a prior submittal, the Contractor shall make every reasonable effort to combine all submittals relating to same class or portion of Work into a common package, regardless of the variety of trades or types of equipment that may be required to construct that portion of Work. e.g. all above ground piping, fittings, valves, actuators, pipe stands, couplings, flow meters and appurtenances shall be submitted as one package for review.
 - 1. Packages that are clearly incomplete will be returned without review.
 - 2. To facilitate approval of critical path items or to facilitate the Contractor’s communication with multiple suppliers and subcontractors, packages may contain several submittals from several suppliers so long as all relevant submittals are contained in the package.
 - 3. Where expedited review of a single submittal within a package is desired to facilitate critical path items, notify the District in writing to request expedited review of said item. The Contractor’s request for expedited review of a portion of a package of submittals shall be taken as full acceptance of responsibility by the Contractor for any subsequent field modifications or substitutions later found necessary to correct any lack of coordination between expedited submittals and other submittals or to correct any lack of coordination between expedited submittals and Contract Documents not brought to the District’s attention at time of submittal.

MOULTON NIGUEL WATER DISTRICT

- C. Catalog cuts may be manufacturer’s pre-printed drawings and need not include the project name. However, where multiple products or options are shown in the same catalog cut, the product or option being furnished shall be clearly delineated as specified below.
- D. All submittals shall show US units. For submittals prepared in foreign countries where manufacturer’s literature is printed solely in metric units, the Contractor may make hand annotations to convert to US units as long as annotations are clear and legible. Submittals not bearing US units will be returned without review.
- E. Submittals bearing text in languages other than English will be returned without review.
- F. Shop drawings for piping shall include the following:
 - 1. Key or index showing locations of spools and fittings
 - 2. Order of installation. Each spool shall receive a unique mark number. No other spool or fitting, even on separate pipelines or casings included in the contract, shall have the same mark number. The sequential order of the mark numbers shall correspond to a logical order of installation for each pipeline.
 - 3. Laying lengths, dimensions, clearances and tolerances for all spools and fittings
 - 4. Clearly legible drawing showing each pipe fitting and/or spool in plan view and in profile
 - 5. Station and invert elevation of all grade changes and changes in horizontal alignment
 - 6. Slopes of pipe not vertical or horizontal
 - 7. Horizontal and vertical alignment data for all curves, bends, tees and outlets
 - 8. Couplings and end types of all pipe, spools, fittings, outlets and adjacent valves or pipeline equipment
 - 9. Proposed pipeline linings and coatings including thicknesses
 - 10. How connections will be made between Work under this contract and existing work or work under other contracts
 - 11. Pipe, and valve support sizes and locations including anchor bolt sizes and embedments
 - 12. Relationship of piping to other Work
- G. Shop drawings for valves or pipeline equipment shall include the following:
 - 1. Laying lengths and dimensions, clearances, tolerances and end types
 - 2. Weight and type of valves or equipment
 - 3. Valve port sizes and tolerances
 - 4. Dimensions and orientation of actuators and pilot systems, locations of actuator stops
 - 5. Proposed linings and coatings
 - 6. Performance characteristics
 - 7. Parts and materials lists and ratings and details of appurtenances to be furnished, along with references to appropriate ASTM, Federal Specifications and other reference standards and grades
 - 8. Piping and conduit attachments and sizes

- H. Shop drawings for equipment shall include the following:
 - 1. Dimensions, clearances and floor space requirements
 - 2. Weight and type of equipment
 - 3. Location where product will be installed
 - 4. Anchor bolt sizes and embedments
 - 5. Finishes and coatings
 - 6. Performance characteristics
 - 7. Parts and materials lists, ratings, and details of appurtenances shall be furnished, along with references to appropriate ASTM, Federal Specifications, and other reference standards and grades
 - 8. Piping and conduit attachments and sizes
- I. Shop drawings for replacement items shall include field measurements needed to verify fit in existing spaces.
- J. Catalog data shall clearly indicate applicable items when several products are covered on one page. Indicate on submitted catalog data, specification section or plan reference being satisfied.
- K. Installation or application instructions shall be Manufacturer's printed instructions including warranty requirements, clearances required and proper field procedures to deliver, handle, install and prepare product for use. In the absence of Manufacturer's published literature, ASTM, AWWA, or trade standards for proper installation will usually be accepted. If no instructions at all are submitted for installing or applying an item of Work, the District reserves the right to stop work on subject item at any time, and to retain experts of the District's choosing to prepare appropriate installation or application instructions to control the Contractor's work. Installation instructions shall include recommended bolt torques for assembly and installation of bolted items.
- L. Operation and maintenance instructions shall be Manufacturer's printed instructions for correct operation and maintenance procedures for each product, along with data which must accompany the manual as directed by current regulations of governmental agencies. Include operating instructions for each piece of equipment. Describe equipment function, operating characteristics, limiting conditions, operating instructions, startup procedures, normal and emergency conditions, regulation and control, and shutdown. Include preventative maintenance instructions. List warranty requirements. Explain and illustrate preventative maintenance tasks. Include lubrication charts, lists of acceptable lubricants, trouble shooting instructions, and lists of required maintenance tools and equipment. List recommended spare parts, their costs, and ordering information for at least one manufacturer who can supply these parts. Index instructions for easy reference. Include information for installed equipment only.
- M. Manufacturer's Statement of Responsibility shall be a copy of the attached form, signed by an authorized factory representative for the manufacturer whose product is being furnished.
- N. Certificate of compliance shall certify that the materials or procedures have been sampled, tested, and found to comply with applicable reference standards, and shall be accepted by the District prior to shipping items described therein.

- O. Engineering calculations shall be clear and legible, shall follow recognized engineering principles, and shall be sufficiently detailed to permit confirmation of the procedures used. Where published tables or charts are included in calculations, clearly show design or load variables used to make selection, highlighting applicable columns or rows in tables and highlighting intersecting variables on chart axes. Engineering calculations shall demonstrate compliance with current state and local codes, applicable standards, and contract requirements. Calculations shall be sealed by a registered engineer licensed in State of California. Calculations or drawings bearing seals with expired expiration dates will not be accepted.
- P. Foundry or test record transcripts shall fully describe required tests in accordance with specified test standards, shall certify that factory quality control, testing, and inspection requirements have been successfully completed and shall be accepted by the District prior to shipping items described therein.
- Q. Furnish the following submittals

SUBMITTAL	DESCRIPTION
Manufacturer’s Written Acceptance of Installation (where "Manufacturer's Statement of Responsibility" is required)	Written acceptance of installation of products shall be certified and submitted by authorized factory representative. This written acceptance shall state that factory authorized representative has inspected installation, alignment, lubrication, and operation of furnished equipment and found it to fully comply with specified design and warranty requirements and are ready for safe operation.
Warranty	Unless otherwise stated, furnish one-year warranty from date of final acceptance.

- R. The District’s review of submittals shall be limited to review of products to be incorporated in Work and to remain in place upon project completion. The Contractor shall have sole responsibility at all times for construction means, methods and jobsite safety. The Contractor shall retain services of California-licensed civil, structural, or traffic engineer, as appropriate, to design and prepare plans for necessary safety equipment required by OSHA, Cal OSHA and other state and local regulatory authorities during construction, and to prepare summary documents for the Contractor’s use for accomplishing said work including, but not limited to sheeting, shoring, trench plating, excavation protection, falsework, formwork, scaffolding, barricading, pedestrian safety and traffic control. Originals of summary documents, signed and sealed by engineer of record who prepared them, shall be submitted solely as proof this requirement has been fulfilled. Since the Contractor has sole responsibility for means, methods and jobsite safety, review of said documents will be limited to verifying preparing engineer’s registration is current and that engineer of record has no active complaints filed against them with the California Board for Professional Engineers and Land Surveyors.
- S. Use of contract drawing reproductions for shop drawings is subject to rejection.

1.08 SAMPLES

- A. Furnish samples, finished as specified, and as intended to be used on or in Work. Send samples to the District, carriage prepaid.

- B. Submit samples at least 21 days before date by which the District's acceptance is required. Allow at least 14 days for review and return of samples.
- C. Submit two of each sample, except for field samples. Attach completed the Contractor's submittal form to the sample. List all items being transmitted, stating proposed use and location, product, color, trade name, lot, style, and model as appropriate.
- D. Resubmit samples until acceptable. One of each sample will be returned to the Contractor upon acceptance.
- E. Samples of finishes shall be 8" x 10" and shall be of minimum thickness consistent with sample presentation. In lieu thereof, submit actual full-size item.
- F. Samples of value may be returned to the Contractor for use in Work after review, analysis, comparison, and/or testing as may be required by the District.
- G. Furnish one sample of accepted products, colors, or textures to the District for final record. Show identification previously described on the back of the sample, including, if finish sample, manufacturer, mix proportion, name of color, building, the Contractor, subcontractor, and any surfaces to which applied.

1.09 CONSTRUCTION PHOTOGRAPHS

- A. Preconstruction photographs shall be submitted to the District before Work is performed which has potential to disturb or modify public or private property not owned by the District. Photographs shall be of sufficient quality and thoroughness to fully document preexisting damage or wear to photographed property for which the Contractor or the District might be asked to compensate property owner were it not for photographic evidence of preexisting damage. Where existing cracks in concrete, masonry or other materials are wider than the thickness of a dime, include a dime or similar visual standard in a photo or video for reference.
- B. Failure by the Contractor to submit preconstruction photographs may be taken by the District as evidence that subsequent claims by property owners for damage to their property can be rightfully attributed to the Contractor's actions.

1.10 NOTIFICATION OF AFFECTED RESIDENCES AND BUSINESSES

- A. Written notification, with the Contractor's 24-hour emergency phone number, shall be provided to residences and businesses fronting the project on either side of street. Notify these parties 72 hours in advance of construction which will affect these properties. Door-hangers or other means of notification shall be submitted to and accepted in advance by the District. For Capital Improvement projects, the District will notify residents and businesses.

1.11 PAYMENT

- A. Payment for submittals and re-submittals will be included in the bid price for those items of Work for which the submittals are required.

PART 2 PRODUCTS (NOT USED)

PART 3 EXECUTION (NOT USED)

END OF SECTION

MANUFACTURER'S STATEMENT OF RESPONSIBILITY

Project Name: _____

Specification Section Number: _____

Item: _____

Serial Numbers: _____

District: _____

Contractor: _____

Supplier: _____

1. **We have reviewed the applicable sections of the Contract Documents** describing requirements for our product, including Sections entitled "Submittal Procedures," "Quality Requirements," "Product Requirements," "Starting and Adjusting," "Closeout Procedures," "Operating and Maintenance Data," "Demonstration and Training," "Basic Civil Engineering Requirements," and "Painting and Coating."

2. **Before shipping, we promise to review Contractor's submittals from other manufacturers** who will supply products that interface with our product, and may affect our product's performance. In addition, we promise to request and review data concerning quality of water, soils or any other materials which may contact or adversely impact performance of our product.

3. **Should we have cause to believe that our product is, for any reason, incompatible** with an interfacing product or material, we will inform the District of our concern before shipping our product. In such case, we will not ship our product until our concerns have been satisfactorily resolved.

4. **We further understand that the District reserves right to request a factory authorized representative's written acceptance of installation, application and/or erection of our product** as described in Section of Contract Documents entitled "Starting and Adjusting", before paying Contractor for our product.

Authorized Factory Representative

SHOP DRAWING TRANSMITTAL FORM

FROM: _____ DATE: _____
company name

PROJECT: _____

CONTRACT NUMBER: _____

TO: Moulton Niguel Water District
26161 Gordon Road
Laguna Hills, CA 92653
attn: Project Manager

SUBMITTAL NO.: _____ ORIGINAL: Y / N REVISION NO.: _____
circle one

SUBJECT OF SUBMITTAL: _____

SPECIFICATION SECTION(S): _____

PLAN SHEET NUMBER(S): _____

CONTRACTOR'S CERTIFICATION: Check & Complete either (A) or (B) below:

(A) We have reviewed in detail and certify that the material, equipment, or construction procedures (s) contained in this submittal meet all the requirements specified in or shown on the Contract Documents, Construction Specifications and Construction Plans with no exceptions.

(B) We have reviewed in detail and certify that the material, equipment, or construction procedures (s) contained in this submittal meet all the requirements specified in or shown on the Contract Documents, Construction Specifications and Construction Plans except for the following deviations:

CONTRACTOR'S AUTHORIZED SIGNATURE:

SECTION 01350

PROJECT ASSET REGISTER

PART 1 GENERAL

1.01 SECTION INCLUDES

- A. General procedures and requirements for developing and populating a Project Asset Register.

1.02 PROJECT ASSET REGISTER

- A. Contractor shall populate project-specific asset information in the electronic Project Asset Register template provided by the District. The Project Asset Register is a spreadsheet, organized by Discipline and Asset Class with a separate tab for each Asset Class. Each tab is labeled by a discipline letter prefix (e.g., C for Civil, M for Mechanical, etc.) followed by the Asset Class per the table below. Asset-specific information for all assets that were added or replaced as part of the project shall be populated on the corresponding Asset Class tab.

Asset Class by Discipline		
Civil	Mechanical (Continued)	Electrical (Continued)
Fence	Hoist Assembly	MCC
Hardscape	HVAC	Motor
Paving	Irrigation System	SMC
Structural	Mixer	Starter
Building	O2 Generation System	Transformer
Communication Structure	O2 Detention Cone	VFD
Crane Assembly	O2 DOCS Blower	I/C
Grating	O2 Scroll Pump Unit	Communication Antenna
Hatch	Onsite Generation System	Dialer
Reservoir	Piping	Dissolved Oxygen Meter
Trailer	Pump	Gas Detection System
Vault	Skimmer	HMI
Wet Well	Sludge Collector	Instrumentation
Mechanical	Storage Bin	Network Cabinet
Bar Screen	Storage Silo	Network Switch
Blower	Surge Tank	O2 Atmospheric Sensor
Boiler	Tank	O2 DOCS Controller
Centrifuge	Truck Scale	O2 Mass Flow Controller
Compactor	Valves	O2 PLC
Compressor	Electrical	PLC
Conveyor	Actuator	Power Monitor
Disc Thickener	ATS	Process Controller
Engine	Breaker	Sampler
Eyewash	Electrical Panel	
Fan	Generator	
Flame Arrestor	Generator Battery	
Flare	Generator Control Panel	Abbreviations: ATS Automatic Transfer Switch HMI Human Machine Interface MCC Motor Control Center PLC Programmable Logic Controller SMC Soft Motor Control VFD Variable Frequency Drive
Flow Meter	Generator Fuel Tank	
Gear Box	Generator Load Bank	
Grinder	Harmonic Filter	
Grit Classifier	Lighting System	
Heat Exchanger	Manual Transfer Switch	

B. Prepopulated Asset Information

1. Each asset to be added or replaced as part of the project will be prepopulated with the following asset attributes:
 - a. **MNWDAssetID:** Unique Asset ID for each asset, used throughout the construction contract documents
 - b. **SiteName:** Site at which the asset is located
 - c. **FacilityName:** Facility at which the asset is located on the site
 - d. **Discipline:** Discipline associated with the asset per the table in 1.02.A
 - e. **AssetClass:** Asset class associated with the asset per the table in 1.02.A
 - f. **AssetType:** Subcategory of the asset class
 - g. **AssetName:** Descriptive name, which includes the function or relation of the asset
 - h. **Description:** Specific location of the asset within the site/facility
 - i. **Owner:** Moulton Niguel Water District or other agency if shared facility
 - j. **System:** Potable, Recycled, or Wastewater

PART 2 PRODUCTS (NOT USED)

PART 3 EXECUTION

3.01 CONSTRUCTION

- A. Once a material submittal has been accepted by the District, the Contractor shall populate the asset information for that asset in the Project Asset Register. Contractor is responsible for populating the attributes in the columns labelled as “CONTRACTOR”.
- B. Contractor shall provide an updated copy of the Project Asset Register as part of their monthly progress payment applications for review and verification by the District.

3.02 PROJECT CLOSEOUT

- A. Upon completion of the project, Contractor shall submit a completed Project Asset Register.
- B. The final Project Asset Register and all associated asset submittals shall be reviewed and accepted by the District prior to final payment or release of any bonds.

- C. As-Built Drawings

1. Where there are differences between the asset data shown on the Construction Contract Drawings compared to the Project Asset Register, Contractor shall redline the As-Built Drawings to match the asset data in the Project Asset Register.

D. Asset Submittals

1. Photos

- a. Contractor shall provide the following photos for each installed asset. Photos shall be taken in landscape orientation only and shall be provided in .jpg format, minimum 12 megapixels. Photo files shall be named according to the following convention:

View	File Name*	Description
Zoomed Out	[MNWDAssetID]-ZoomedOut	Asset with surroundings visible
Close Up	[MNWDAssetID]-CloseUp	Asset visible in full frame
Nameplate	[MNWDAssetID]-NamePlate	Asset nameplate in full frame (all info on nameplate must be legible)
Other	[MNWDAssetID]-Other	For use when needed

*When additional photos of the same view are warranted, the name format shall include a “2”, “3”, etc. suffix (e.g., [MNWDAssetID]-CloseUp2)

2. Product Data

- a. Contractor shall provide product data for each asset. The product data required for a particular asset type is indicated in the Project Asset Register. Product data files shall be named according to the following convention:

File Name	Description
[ContractNo][SubmittalNo]-ProductData	Product Submittal (e.g., material data sheet)
[MNWDAssetID]-PumpCurve	Pump Curve
[MNWDAssetID]-FieldTesting*	Field Performance Testing
[MNWDAssetID]-CertInstall*	Manufacturer’s Certificate of Installation
[MNWDAssetID]-Warranty*	Warranty Information
[MNWDAssetID]-OMManual*	O&M Manual

*For projects where these documents contain multiple assets, substitute [MNWDAssetID] for [ContractNo][SubmittalNo].

- b. File Format: Product data files shall be provided in .pdf format. Only original files with fully searchable and clearly legible text will be accepted.

END OF SECTION

SECTION 01550
BYPASS PUMPING

PART 1 GENERAL

1.01 SECTION INCLUDES

- A. Bypass pumping requirements

1.02 SUBMITTALS

- A. Bypass Pump Plan:
 - 1. Submit to the District for acceptance within 4 weeks of Notice to Proceed.
 - 2. Plan shall include, but not limited to, the following topics:
 - a. Number of primary, lag and standby pumps, product data sheets for the proposed pumps, discharge capacities of pumps, all related appurtenances (suction and discharge hoses/piping; valving; sensors or controls);
 - b. Calculation of static lift, friction losses, and flow velocity (include pump operating curves);
- B. Spill Prevention and Emergency Response Plan
- C. Spill Incident Report:
 - 1. Submit report within three (3) working days from the occurrence of the spill.
 - 2. Report shall include the following information related to the spill: Location, date, time, duration, spill volume, cause, and corrective actions.

1.03 QUALITY ASSURANCE

- A. Qualifications: The bypass pumping subcontractor shall have at least five (5) verifiable references of projects of a similar size and complexity as the proposed project performed by their firm within the last three years.
- B. Pollution Liability Insurance: The Contractor shall obtain and maintain an additional insurance coverage for Pollution Liability.

PART 2 PRODUCTS

2.01 DESIGN CRITERIA

- A. Flow Rates
 - 1. The bypass system shall be capable of pumping a minimum of 120 percent of the required peak flow rate after head and friction loss factors are accounted for.

2. Peak Dry Weather Flow may be used for single day bypass activities that will not commence in a rain event.
3. Peak Wet Weather Flow shall be used for rehabilitation activities that will commence in a rain event or for a bypass system that may remain in service overnight.
4. Flow rates may be available from the District. At discretion of the District, the Contractor shall be required to provide flow monitoring to verify flow rates.

B. Sound

1. The Contractor shall ensure the pumps and generators are “critically silenced” with a maximum allowable sound level of 70 dba at the nearest building façade or as otherwise required by agency having jurisdiction.

2.02 SYSTEM

A. Pumping System:

1. Provide redundant, identically sized, one hundred-percent backup bypass pumping system.
2. Provide minimum of two pumping units, duty and standby.
3. Each pump, including the backup pumps, shall be a complete unit with its own suction and discharge piping.
4. If electric power driven pumps are used, provide an emergency standby power generator even when the pumps are powered with commercial power.

B. Fuel Tanks:

1. Provide one (1) dedicated fuel tank for every single pump/generator, if fuel/generator driven pumps are used.
2. The Contractor shall provide a fuel level indicator outside each fuel tank.
3. The Contractor shall take the necessary measures to ensure the fuel supply is protected against contamination. This includes but is not limited to fuel line water traps, fuel line filters, and protecting fuel stores from precipitation.

PART 3 EXECUTION

3.01 BYPASS PUMPING

- A. Continuous full-time monitoring by a person qualified and trained to operate and maintain the bypass pumps and bypass system shall be provided by the Contractor.
- B. Fully install backup bypass pumping system and ensure it is operational and ready for immediate use.
- C. The Contractor shall demonstrate to the satisfaction of the District that both the primary and backup bypass pumping systems are fully functional and adequate, and shall certify the same, in writing, in a manner acceptable to the District.
- D. Provide traffic ramps where hoses/pipes cross traffic ways.

3.02 SPILL PREVENTION AND EMERGENCY RESPONSE

- A. The Contractor shall comply with the District's policy of zero spills and is responsible for preventing and containing any sewage spillage.
- B. The Contractor shall make every effort to eliminate spill risk by providing containment around bypass system and in the location that the sewer will be opened up.
- C. In case of a sewage spill(s), the Contractor shall act immediately without instructions from the District, to control the spill and take all appropriate steps to contain it.
- D. The Contractor is responsible for the recovery and legal disposal of any spilled sewage and liability arising from negligently causing a sewage spill and shall defend, indemnify, protect, and hold harmless the District, its agents, officers, and employees, from and against all claims asserted, or liability established for damages or injuries to any person or property resulting from any sewage spill caused or claimed to be caused by the Contractor's action or failure to take measures to prevent a spill. The Contractor shall also be responsible for payment of any fines and/or penalties assessed against the District for such sewage spills. The Contractor's duty to indemnify and hold harmless shall not include any claims or liability arising from the established sole negligence or willful misconduct of the District, its agents, officers or employees.

END OF SECTION

SECTION 01615

FACILITY IDENTIFICATION

PART 1 – GENERAL

1.01 SUMMARY

- A. This section covers the furnishing and installation of nameplates and tags for identification of equipment, valves, panels, and instruments.

1.02 GENERAL

- A. Except as otherwise specified in equipment, valve, and instrumentation sections, nameplates and tags shall be as specified herein. Nameplates or tags shall be provided for all equipment, valves, operator interfaces, control and electrical panels, cabinets, instruments, and instrument racks that have been named and/or tagged on the Drawings.

1.03 RELATED SECTIONS

- A. The WORK of the following Sections applies to the WORK of this Section. Other Sections of the Specifications, not referenced below, shall also apply to the extent required for proper performance of this WORK.
 - 1. Section 01300 Submittal Procedures.
 - 2. Section 01350 Project Asset Register.
 - 3. Section 09900 Painting and Coating.

1.04 SUBMITTALS

- A. Drawings and data shall be submitted in accordance with the requirements of the Submittals Procedures section for each type of tag provided including materials, colors, sizes, letter sizes, and installation instructions.
- B. Contractor shall submit two sets of representative samples of nameplates and tags for acceptance by Owner.

PART 2 - PRODUCTS

2.01 EQUIPMENT NUMBER PLATES

- A. The Contractor shall provide number plates bearing the equipment tag number identified on the Drawings and the asset identification assigned by the Owner for all equipment tagged on the drawings. If the equipment is submerged then the number plates shall be provided at the top of rails above the submerged equipment. Number plates shall be bevelled, 1/8 inch thick laminated black phenolic plastic engraving stock with white core. Lettering on number plates shall be capitalized block letters 3/4 inch high. Number plate height shall be twice the letter

height. Number plate length shall be as needed, with suitable margins all around. Lettering shall be placed in one row where practicable; however, where necessary due to excessive length, lettering shall be placed on more than one row and centered.

- B. Number plates shall be attached with stainless steel panhead screws, rivets, or drive screws.
- C. When a number plate cannot be installed due to the physical size, space, or mounting surface geometry of the equipment, the Contractor shall provide a 12 gauge stainless steel tag with engraved or imprinted equipment tag number. Lettering on tags shall be $\frac{3}{4}$ inch high. Tags shall be rectangular with smooth edges and shall be fastened to the equipment with stainless steel mechanical fasteners or with a stainless steel chain.

2.02 EQUIPMENT INFORMATION PLATES

- A. The manufacturer shall provide Equipment with engraved or stamped equipment information plates securely affixed with mechanical fasteners to the equipment in an accessible and visible location. Equipment information plates shall be in addition to the number plates specified. Equipment information plates shall indicate the manufacturer’s name, address, product name, catalog number, serial number, capacity, operating and power characteristics, labels of tested compliances, and any other pertinent design data. Equipment information plates listing the distributing agent only will not be acceptable.

2.03 VALVE AND GATE TAGS

- A. Temporary Tags.
 - 1. Each valve and gate with an identifying number indicated on the Drawings or listed in the valve or gate schedule, shall be tagged or marked in the factory with the identifying number.
 - 2. The asset identification number assigned by the Owner shall also be included on the tag.
- B. Permanent Tags.
 - 1. All valves and gates, except buried or submerged valves, that have been assigned a number on the Drawings or in the valve or gate schedule, shall be provided with a permanent number plate. Tags shall be permanently attached to valves and gates with stainless steel mechanical fasteners or with stainless steel chains. Numerals shall be $\frac{3}{4}$ inch high and shall be black baked enamel on an anodized aluminum plate.

2.04 PANEL NAMEPLATES

- A. Nameplates shall be provided on the face of each panel and cabinet. Panel identification nameplates shall be mounted at the top of the panel shall include the panel descriptive name and tag number as indicated on the Drawings, in two or three lines of text. Lettering shall be $\frac{3}{4}$ inch high.
- B. Nameplates for devices mounted on or in the panel shall be inscribed with the text as indicated on the Drawings. Where nameplate information is not indicated on the Drawings, inscriptions shall be in accordance with information in the supplier’s submittal drawings as

guided by information in the relevant specification section. Panel device nameplates shall have engraved letters $\frac{3}{4}$ inch high.

- C. Nameplate material and size shall be as specified above for equipment number plates. Nameplates shall be secured to the panel with stainless steel panhead screws.

2.05 INSTRUMENT TAGS

A. Temporary Tags

- 1. Where instruments are not provided with permanent tags furnished from the factory, instruments shall be tagged or marked in the factory with the instrument tag number indicated on the Drawings.

B. Permanent Tags

- 1. Instruments shall be tagged with the instrument tag number indicated on the Drawings. Tags shall be 12 gauge stainless steel with engraved or imprinted symbols. Lettering on tags shall be $\frac{3}{4}$ inch high. Tags shall be rectangular with smooth edges, and shall be fastened to the instrument with stainless steel mechanical fasteners or with a stainless steel chain.

C. Conduit

- 1. Conduit endpoints shall be labeled to indicate:
 - a. Power
 - b. Control
 - c. Instrumentation
 - d. Conduit ID

2.06 PIPE LABELS

A. Pipe Labels

- 1. Pipes shall be labeled with lettering according to the pipe tags shown on the Drawings.
- 2. Pipe labels shall include flow arrows indicating the direction of flow.
- 3. Where the outside diameter of pipe or pipe covering is $\frac{5}{8}$ inch or smaller, aluminum or stainless steel tags shall be provided instead of lettering. Tags shall be stamped as specified and shall be fastened to the pipe with suitable chains.
- d
- 4. Pipe labeling shall be color coded as directed by the Engineer.

PART 3 – EXECUTION (NOT USED)

END OF SECTION

SECTION 01630

PRODUCT SUBSTITUTION PROCEDURES

PART 1 GENERAL

1.01 SECTION INCLUDES

- A. Procedures and requirements for substituting products

1.02 RELATED REQUIREMENTS

- A. Section 01330, Submittal Procedures

1.03 GENERAL REQUIREMENT

- A. In compliance with the provisions of Section 3400 of the Public Contract Code of the State of California, the Contractor will have thirty (30) calendar days after award of the contract to submit data substantiating a request for substituting any “or equivalent” items. Substitution requests shall be submitted and accepted by the District prior to the Contractor ordering materials.
- B. Standard Products - Where products are specified by reference standard, any product meeting the standards referenced may be used. Information on such products shall be submitted in accordance with the requirements of Section 01330.
- C. Proprietary Products – Where products or processes are specified or listed in the approved material list by trade, patent or proprietary name, said specification or approved material list, unless marked "no exceptions", shall be deemed to be followed by the words "or accepted equal accepted in writing by the District." In such case substitution of similar products as “accepted equals” will be considered under this section.
- D. Selection of Proprietary Product - Where more than one proprietary name is specified or listed in the approved material list, the Contractor may provide any one of the products specified. Only one manufacturer shall be used for each specific application throughout the Work notwithstanding that similar materials or equipment of two or more manufacturers or producers may be specified for the same application.
- E. Substitution Request Procedure - Submit a written request on the enclosed form for proposed substitutions to the District prior to deadline for receipt of substitution requests. Submit proposed substitutions relating to a particular subcontract or trade in a single package. If the District accepts any proposed substitutions, such acceptance will be set forth in an Addendum. No substitution will be considered after the deadline for receipt of substitution requests has expired.

MOULTON NIGUEL WATER DISTRICT

- F. Contractor's Responsibility for Construction Modifications - Drawings have been detailed in compliance with dimensions and International Council of Building Officials (ICBO) Evaluation Report data for products specified. If proposed substitute product is accepted by the District, the Contractor shall assume both responsibility for construction modifications and additional costs required by reason of this acceptance. If substitution results in a decrease in cost, potential savings to the District may be submitted to the District for consideration.
- G. Systems of Like Manufacture - Where products are specified in groups to be furnished by one manufacturer, no substitution will be considered that is not similarly furnished by one manufacturer. Where the Contractor proposes to use a system of equipment other than that shown in the Contract Documents, the substitution shall be proposed as a complete system.
- H. No time extension will be allowed for substitution of materials.
 - 1. Submittals
 - a. Furnish the following submittals for substitution requests.

SUBMITTAL	DESCRIPTION
Substitution Request Form	Submit Substitution Request on form furnished at the end of this section.
Contractor's Certification of Performance and Assumption of Liability	Submit Certificate of Performance certifying that the proposed substitution is equal to or better in all respects to the product specified and that the proposed substitution will, in all respects perform the function for which it is intended.
Certificate of Compliance	Required as needed to substantiate Product Substitutions
Dimensional Data	Required for Product Substitutions
Material Samples	Required as needed to substantiate Product Substitutions
Manufacturer's Statement of Responsibility	Required at District's discretion for Product Substitutions. See form at end of Section 01330.
Foundry or Test Record Transcripts	Required as needed to substantiate Product Substitutions
Material List and Ratings	Required as needed to substantiate Product Substitutions
Names and Addresses of Nearest Local Manufacturer's Representatives	Required for Product Substitutions (Use allotted space on attached Substitution Request Form)
List of Three Local Product Installations	Names and contact information for three installations within a 100 mile radius of project completed within the prior three years. Required for Product Substitutions (Use allotted space on attached Substitution Request Form)
Manufacturer's Service Contract Statement of Qualifications	Required for installations of products which include optional maintenance service contracts

SUBMITTAL	DESCRIPTION
Warranty	Furnish warranty equal to or better than warranty required for specified product.

- b. Determination of Equality - The burden of proof for demonstrating equality of the substituted item shall be the responsibility of the Contractor. Acceptance of such substitutions is entirely at the discretion of the District.
 - c. List of Accepted Substitutions - The District will issue to the Contractor a list setting forth those substitutions that have been accepted. No products proposed for substitution, shall be ordered before being accepted in writing by the District.
 - d. Products accepted as "accepted equals" shall, in the District's opinion, meet the following requirements:
 - 1) Products shall be of equal quality, substance, function, and color to those listed.
 - 2) Products shall be standard products of a reputable manufacturer having regularly been engaged for 5 years in manufacture of products furnished.
 - 3) Products shall have a reputation for assuring long-lasting trouble-free service.
 - 4) Factory-authorized, factory-trained, and competent service personnel, and stocked service parts shall be available within a 150 mile radius of the Work.
 - 5) Manufacturer shall be capable of certifying compliance with listed reference standards.
 - e. The District reserves the right to reject product substitutions solely on the basis of maintenance of economies of scale available to the District through standardizing on manufacturers and minimizing spare parts inventories.
 - f. Denial of Substitution - If, in the opinion of the District the proposed substitution is not equal to or better in every respect to that of the specified product, or was not submitted for acceptance in the manner outlined above, the Contractor shall furnish the specified products.
 - g. Responsibility for Coordinating Substitutions with Construction Trades – the Contractor shall inform all other trades, vendors, and subcontractors of the effects of substitutions on their work or products. Failure to notify shall not relieve the Contractor of their duty to make payments arising from alterations in specified products or methods needed to complete the Work in an approved and acceptable manner.
2. Contractor's Responsibility for Cost of Substitution Reviews
 - a. The Contractor shall pay all costs incurred by the District to review Requests for Substitutions.
 3. Responsibility for Spare Part Inventories
 - a. Provide spare parts inventory to accommodate two years' typical maintenance. See technical specifications for further information for specific equipment items.
 4. Substitution of "Inferior" Products
 - a. Products not meeting the above requirements shall, for purpose of this contract, be deemed "inferior" even if product's only shortcoming is that the Contractor failed to submit a Substitution Request on said product prior to the stipulated deadline.

MOULTON NIGUEL WATER DISTRICT

- b. Substitution of "inferior" products shall not occur except where cost savings are offered to and accepted by the District in the form of a Change Order.
5. Bid Shopping and Reverse Auctions
- a. Substitutions for products and services of Manufacturers, system integrators or subcontractors listed at time of bid and/or in the Contractor's initial Submittal will only be permitted under one or more of the following circumstances:
 - 1) Where the Contractor-listed manufacturer, system integrator, or subcontractor has gone out of business.
 - 2) Where the Contractor-listed manufacturer, system integrator or subcontractor has, in the District's opinion, failed to perform or no longer possesses both capability and willingness to perform to standard required by Contract Documents.
 - 3) Where the Contractor-listed manufacturer, supplier, or subcontractor increases price quoted to the Contractor above, that quoted at time of bid, and the Contractor submits evidence of this acceptable to District.
 - 4) Where the Contractor offers a credit to the District sufficient in the District's opinion to justify accepting the substitution in the form of a Change Order.

PART 2 PRODUCTS (NOT USED)

PART 3 EXECUTION (NOT USED)

END OF SECTION

SUBSTITUTION REQUEST FORM

TO: _____
District

Address

City/State/ZIP

PROJECT NAME: _____

FROM CONTRACTOR: _____

We hereby submit for consideration the following product substitution of specified item for above project:

DRAWING OR SECTION NO.		SHEET NUMBER OR PARAGRAPH		SPECIFIED ITEM

PROPOSED SUBSTITUTION: _____

1. Attach complete dimensional information and technical data needed to substantiate product substitution, including ICBO reports and laboratory tests, if applicable.
2. Include complete information on changes to Drawings and/or Specifications which proposed substitution will require for its proper installation.
3. Where product substitutions are proposed at multiple locations, submit copies of plans showing in red each location where the product substitution is proposed.
4. Submit with request all necessary samples and substantiating data to prove equal quality and performance to that which is specified. Clearly mark manufacturer's literature to indicate equality in performance. Differences in quality of materials and construction shall be indicated.
5. Submit Manufacturer's Statement of Responsibility.

SUBSTITUTION REQUEST FORM

Fill in Blanks Below:

- A. Does the substitution affect dimensions shown on Drawings?
Yes___ No___ If yes, attach copy of plans and clearly indicate changes.
- B. Will the undersigned pay for the changes to the building design, including engineering, detailing and review costs caused by the requested substitution? Yes___ No___
- C. What effect does the substitution have on other trades?
1. _____
2. _____
- D. What effect does substitution have on applicable code requirements?
1. _____
2. _____
- E. What is the ICBO Approval Number: _____
- F. Differences between proposed substitution and specified item:
1. _____
2. _____
- G. List three installations where product is in use:
1. _____
2. _____
- H. Address of Authorized Manufacturer's Representative:

Representative

Address

City/State/ZIP
- I. Manufacturer's guarantees of the proposed and specified items are:
Same___ Different___ (Explain) _____
- J. District's share of cost savings if substitution is approved \$_____

SUBSTITUTION REQUEST FORM

**CONTRACTOR’S CERTIFICATION OF PERFORMANCE AND
ASSUMPTION OF LIABILITY FOR EQUAL PERFORMANCE**

I certify that the proposed substitution is equal to or better in all respects to the product specified and that the proposed substitution will, in all respects perform the function for which it is intended.

Submitted By:

Date: _____

Signature: _____

Title: _____

Firm: _____

Address: _____

Telephone: _____

For use by District:

_____ Accepted

_____ Accepted as Noted

_____ Not Accepted

_____ Received Too Late

By: _____

Date: _____

Remarks: _____

Concurrence By:

District

Signature must be by person having authority to legally bind their firm to the above terms.
Failure to provide legally binding signature will result in retraction of approval.

SECTION 01650

PRODUCT DELIVERY, STORAGE, AND HANDLING REQUIREMENTS

PART 1 GENERAL

1.01 SECTION INCLUDES

- A. Transportation and handling, storage and protection of products

1.02 REFERENCED STANDARDS

- A. California Stormwater Quality Association (CASQA) Stormwater Best Management Practice Handbook for Construction latest edition
- B. ANSI/NSF 61 Drinking Water System Components – Health Effects

1.03 DELIVERY, STORAGE AND HANDLING

- A. Ship and deliver products to jobsite as follows:
 - 1. Do not ship, accept delivery of, or store items on site for which applicable submittals have not been accepted.
 - 2. Before shipping, operate valves, motors, pumps, actuators, and mechanical equipment at the factory to ensure products are complete and in working condition.
 - 3. Only products of accepted manufacturers shall be delivered to or stored at the site.
 - 4. Deliver products to the jobsite in manufacturer's original, unbroken, unopened, labeled packaging containers or bundles. Tag or label packages, containers, or bundles as needed to identify contents and name of equipment of which contents form a part.
 - 5. Deliver large multi-component assemblies in sections that facilitate field handling and installation.
 - 6. Oil-lubricated gearing, bearings, and other lubricated components shall be shipped with oil soluble protective coating as described in the warranty requirements or as recommended by the manufacturer. For parts contacting potable water, coating shall be NSF-approved. Coating shall provide protection for one year after final acceptance.
- B. Store products at jobsite as follows:
 - 1. Store materials per manufacturer's recommendations, and in a protected area at a temperature between 35 degrees F and 110 degrees F.
 - 2. Store products so as to preserve their quality and fitness for the Work. Locate stored products and equipment to be incorporated in the Work to facilitate prompt inspection. The Contractor shall be responsible for damage or loss to products until Final Acceptance.

MOULTON NIGUEL WATER DISTRICT

3. Protect products against moisture, weather, temperature extremes, dust, debris, tampering, theft, vandalism, ultraviolet radiation, or damage from improper handling, storage, or exposure. Protect exposed metals from rust and corrosion even for items which may be sandblasted or otherwise cleaned before painting.
4. Store items not designed for outdoor exposure off the ground and under cover.
5. Store cementitious materials in weather-tight spaces. Keep free from moisture.
6. Store aggregate in well-drained area to minimize change in moisture content. Prevent contamination by other materials.
7. Store fasteners and connectors in original unopened containers until used.
8. Ventilate materials subject to corrosion or moisture damage to prevent condensation.
9. Any corrosion evident prior to final acceptance shall be removed, or the product shall be removed or replaced.
10. Cover plastic and similar brittle items to protect from sun exposure and temperature extremes.
11. Cover stored materials with tarpaulin or other covering to prevent soiling or exposure to weather. Fasten coverings to prevent removal by wind.
12. Store flammable products to conform with City, County, State, and Federal safety codes for storage of flammable materials.
13. Cover, plug, or cap pipe ends, valve ends and equipment openings with rubber, plastic or canvas to prevent intrusion or contamination.
14. Stringing of pipe along right of way shall be done in a manner that will not interfere with free passage of vehicles.
15. Do not store pipe on roadway or parkway of residential streets for more than 10 days.
16. Store items in accordance with requirements of project Storm Water Pollution Prevention Plan (SWPPP), if applicable. If a SWPPP has not been prepared for the project, store items in accordance with the appropriate best management practices (BMP's) listed in the California Stormwater Quality Association (CASQA) Stormwater Best Management Practice Handbook for Construction latest edition. Comply with all City, County, State, and Federal pollution prevention laws and permits.
17. Notify the District in writing if delivered or stored product is damaged. Exterior surfaces of delivered items shall be in perfect unblemished condition. Do not repair damaged products without prior written approval.

C. Handle products as follows:

1. Handle products with care, using proper equipment according to manufacturer's recommendations. Lift large heavy items only at points designated by manufacturer. Do not drop, drag, bump, bend or handle products in a manner that causes abrasions, bruises, cracks, mars, scars, scratches or other damage. Use padded slings and hooks for lifting as needed to prevent damage. Improper handling shall be cause to reject mishandled products.

MOULTON NIGUEL WATER DISTRICT

2. Coated pipe, valves and other products shall be lifted, lowered or suspended using rubber or canvas belt slings or pneumatic-tired cradles. Sling width shall equal or exceed pipe or product diameter. Do not handle coated products using ropes, hooks, chains, calipers or cables. Store such materials on padded skids.
3. Inspect each product item for damage, defects, completeness and correct operation before installing.
4. Before installation, swab joints and interiors of piping materials to remove foreign matter.
5. Clean and protect machined surfaces and shafting from corrosion using proper type and amount of coating as described in warranty requirements to assure protection to one year after final acceptance.
6. Maintain records for the District's review of deliveries to show Contractor's order number, purchase order number and equipment number. Include labeling or shipping tag in records.

1.04 WARRANTY REQUIREMENTS

- A. Manufacturer's instruction and warranty requirements for delivery, storage and handling of products shall be strictly followed.

PART 2 PRODUCTS (NOT USED)

PART 3 EXECUTION (NOT USED)

END OF SECTION

SECTION 01731

EQUIPMENT OPERATION AND MAINTENANCE MANUALS

PART 1 GENERAL

1.01 SUMMARY

- A. This section covers the preparation and submittal of paper and electronic equipment operation and maintenance (O&M) manuals for pump stations and similar facilities. The Equipment O&M Manuals will be prepared by the Contractor.
- B. The Equipment O&M Manuals are single-source references and shall include all relevant information needed to understand, operate, and maintain the equipment.

1.02 RELATED SECTIONS. The WORK of the following Sections applies to the WORK of this Section. Other Sections of the Specifications, not referenced below, shall also apply to the extent required for proper performance of this WORK.

- A. Section 01300 Submittal Procedures
- B. Section 01650 Product, Delivery, Storage, and Handling
- C. Section 01910 Startup Testing and Commissioning
- D. Division 11 Equipment
- E. Division 15 Mechanical
- F. Division 16 Electrical
- G. Division 17 Other

1.03 O&M CONTENT. The Equipment O&M Manuals will be specific to each **equipment**. At a minimum, the following equipment O&M manuals are anticipated. Additional manuals shall be identified on a project-by-project basis. Draft Equipment Operation and Maintenance Manual shall be submitted in electronic format to the District prior to equipment delivery.

- A. Pumps and motors
- B. Gauges
- C. Flow Meter
- D. Level Control
- E. Sump Pumps

- F. Grinders
- G. Blowers and AC Units
- H. Compressors
- I. Surge Tank
- J. Valves (Check, Ball, Butterfly, Gate, Plug, etc.)
- K. VFDs
- L. Electrical Equipment
- M. Generator
- N. Generator Automatic Transfer Switch
- O. Communications Equipment

1.02 FORMAT OF HARD COPY SUBMITTALS

- A. Hard copies submitted for review shall be temporarily bound in heavy paper covers bearing suitable identification. All manuals and other data shall be printed on reinforced edge, first quality 8-1/2 x 11-inch paper, with standard three-hole punching. Drawings and diagrams shall be reduced to 8-1/2 x 11 inches or 11 x 17 inches. Where reduction is not practicable, larger drawings shall be folded separately and placed in envelopes, which are bound into the manuals. Each envelope shall be suitably identified on the outside. Each volume containing data for three or more items of equipment shall include a table of contents and index tabs. The final hard copy of each manual shall be prepared and delivered in substantial, permanent, three-ring or three-post binders with a table of contents and suitable index tabs.

1.03 FORMAT OF ELECTRONIC SUBMITTALS

- A. Electronic manuals shall be in Adobe Acrobat’s Portable Document Folder (PDF) and shall be prepared at a resolution between 300 and 600 dots per inch (dpi), depending on document type. Optical Character Recognition (OCR) capture shall be performed on these documents. OCR settings shall be performed with the “original image with hidden text” option in Adobe Acrobat Exchange.
- B. File size shall be limited to 50 MB. A single PDF file greater than 50 MB may only be submitted if acceptable to District. When multiple files are required the least number of files possible shall be created. File names shall be in the format OMXXXXX-YYYZ-V.pdf, where XXXXX is the five-digit number corresponding to the specific section, YYY is a three-digit O&M manual number, e.g. 001, Z is the letter signifying a resubmittal, A, B, C, etc., and V is a number used only when more than one XX MB file is required for an O&M manual.
- C. Documents prepared in PDF format shall be processed as follows:
 - 1. Pages shall be searchable (processed for optical character recognition) and indexed when multiple files are required.

2. Pages shall be rotated for viewing in proper orientation.
3. A bookmark shall be provided in the navigation frame for each entry in the Table of Contents.
4. Embedded thumbnails shall be generated for each completed PDF file.
5. Where the bookmark structure is longer than one page the bookmarks shall be collapsed to show the chapter headings only.
6. When multiple files are required the first file of the series (the parent file) shall list every major topic in the Table of Contents. The parent file shall also include minor headings bookmarked based on the Table of Contents. Major headings, whose content is contained in subsequent files (children) shall be linked to be called from the parent to the specific location in the child file. The child file shall contain bookmark entries for both major and minor headings contained in the child file. The first bookmark of any child file shall link back to the parent file and shall read as follows “Return to the Equipment Name Table of Contents”, e.g. Return to the Pump Station Table of Contents.
7. Drawings shall be bookmarked individually.
8. Files shall be delivered without security settings to permit editing, insertion, and deletion of material to update the manual provided by the manufacturer.
9. The opening view for PDF files shall be as follows:

Initial View: Bookmarks and Page
Page Number: Title Page (usually Page 1)
Magnification: Set to Fit in Window
Page: Single Page

1.04 LABELING. At a minimum, the following information shall be included on all final O&M manual materials and hard copy manuals:

Equipment name spelled out in complete words.
Project Name
Contract Number
Equipment Tag Number(s)
Specification Section Number
File Name and Date.

A. For example:

Equipment Name Operation and Maintenance Manual
Somewhere Lift Station Improvements
Project/Contract No. _____
Tag No. _____
Specification Section 11110
OM11110-001.pdf, 5/05/22

1.05 EQUIPMENT OPERATION AND MAINTENANCE DATA AND MANUALS

This section outlines the format and requirements for the Contractor/manufacturer-provided equipment O&M manuals that will be provided during construction.

- A. Adequate operation and maintenance information shall be supplied for all equipment requiring maintenance or other attention. The equipment Supplier shall prepare a Project specific operation and maintenance manual for each type of equipment included on the project.
- B. Operation and maintenance manuals shall explain and illustrate clearly and simply the principle and theory of operation, operating instructions, and preventative and corrective maintenance precautions and procedures to be followed. The manuals and appurtenant materials shall be written entirely in English and all dimensions shall be in English units.
- C. Unless otherwise agreed by Engineer, the operation and maintenance manual for each type of equipment shall only be submitted for review following completion or review of all shop drawings and engineering data pertaining to that equipment.
- D. Equipment O&M manuals shall include the following contents and the information required by the individual specification sections.
 - 1. Title Page: A title page with the following information shall be provided as the first sheet of each manual or each section of the manual or each section of the manual.
 - a. Title of the project.
 - b. Name and address of the project.
 - c. Date of submittal.
 - d. Name, address, and telephone number of the Contractor.
 - e. Name and address of the manufacturer’s representative.
 - f. Cross-reference to related systems in other operations and maintenance manuals.
 - 2. Equipment O&M Manual Table of Contents
 - a. After the title page, each volume of Equipment O&M Manuals will include the complete O&M table of contents.
 - 3. General Information: A general information section shall be provided immediately following the table of contents, with a list, by product name, of each product included in the manual. Under each product, the name, address, and telephone number shall be listed for the subcontractor or installer.
 - 4. Content of the Manual: In each manual, the following information shall be included for each major component of the equipment and controls.
 - a. General equipment description.

- b. Design factors and assumptions.
- c. Reproducible prints of shop drawings including diagrams, wiring diagrams, and schematics, as required under the electrical and instrumentation portions of these specifications.
- d. Equipment identification, including:
 - 1) Name of Manufacturer.
 - 2) Model Number.
 - 3) Serial number of each component.
 - 4) Test certified pump curves.
 - 5) Factory test results.
 - 6) Project specific tag number.
- e. Operating instructions for startup, routine and normal operation, regulation and control, shutdown, and emergency conditions. Include characteristic operating curves.
- f. Tabulation of proper settings for valve and related equipment-protection devices.
- g. Wiring diagrams.
- h. Listing of relay, time delay, switch, and alarm contact settings.
- i. Inspection and test procedures.
- j. Assembly, installation, alignment, adjustment, and checking instructions.
- k. Storage and handling requirements prior to installation and when equipment is not in service.
- l. Special tools, accessories, or instrumentation needed for proper operation, testing, or servicing of the equipment.
- m. Preventive maintenance procedures and schedules.
- n. Precautions against improper use and maintenance.
- o. Lubrication schedules, including:
 - 1) List of all acceptable lubricants and identify the lubricant that will be used.
 - 2) Lubricant grade and type.
 - 3) Temperature range of lubricants.

- 4) Frequency of required lubrication.
- p. Material Safety Data Sheets (MSDS) for any applicable item (chemicals, oils, lubricants, etc.)
- q. Calibration requirements and schedules.
- r. Complete parts list by generic title and identification number, with exploded views of each assembly. The manufacturer's recommended spare parts listing annotated with indications of parts furnished as part of this contract shall be included.
 - 1) Name and location of nearest supplier and spare parts warehouse.
 - 2) Sources of required maintenance materials and related service.
 - 3) Predicted life of parts subject to wear.
 - 4) Manufacturer part numbers.
- s. Guide to troubleshooting and table of applicable error/failure codes.
- t. Disassembly and reassembly instructions.
- u. Repair instructions.
5. Product Data: Where manufacturer's standard printed data is included in the manuals, only the sheets that are pertinent to the part or product installed shall be inserted. Each sheet shall be marked to identify the part or product included in the installation. Where more than one item is included in a tabular format, each item shall be identified using appropriate references from the contract documents. Data that is applicable to the installation shall be identified, and references to information that is not applicable shall be deleted or clearly marked out.
6. The text shall be organized in a consistent format under separate headings for different procedures. A logical sequence of instructions shall be provided for each operations and maintenance procedure.
7. Drawings: Specially prepared drawings shall be provided where necessary to supplement manufacturer's printed data to illustrate the relationship of component parts of equipment or systems.
8. Control or Flow Diagrams: Control and flow diagrams shall be coordinated with information contained in the shop drawings to ensure correct illustration of the completed installation.
9. Safety: Include all safety precautions to be taken when operating and maintaining equipment.
10. Materials and Finishes: Manufacturer's data for all equipment finishes, including product number and information for re-ordering. Manufacturer's recommendations for cleaning agents and methods.

11. Warranties and Service Contracts: When the specifications require a separate warranty or service contract for an item of equipment or a particular portion of the project, a copy of the warranty or service contract shall be included in the manual. The warranties for equipment or equipment components shall be listed and terms and conditions described. Servicing and safety precautions prescribed by the manufacturer to keep warranties in force shall be described. Written procedures to be followed in the event of product failure shall be provided. Circumstances and conditions that affect validity of the warranty or bond shall be included.

PART 2 – PRODUCTS (NOT USED)

PART 3 – EXECUTION (NOT USED)

END OF SECTION

SECTION 01780

DEMONSTRATION AND TRAINING

PART 1 – GENERAL

1.01 SUMMARY

- A. This section contains requirements for training the District’s personnel in the proper operation and maintenance of the equipment and systems installed under this contract.
- B. Where indicated in the Construction Project Schedule and as required by Startup Testing and Commissioning section, the manufacturer’s representative shall provide on-the-job training of the District’s personnel. The training sessions shall be conducted by qualified, experienced, factory trained representatives of the various equipment manufacturers. Training shall include instruction in both operation and maintenance of the subject equipment.

1.02 RELATED SECTIONS

- A. The WORK of the following Sections applies to the WORK of this Section. Other Sections of the Specifications, not referenced below, shall also apply to the extent required for proper performance of this WORK.
 - 1. Section 01300 Submittal Procedures
 - 2. Section 01310 Construction Project Schedules
 - 3. Section 01731 Equipment Operation and Maintenance Manuals
 - 4. Section 01910 Startup Testing and Commissioning
 - 5. Division 11 Equipment

1.03 SUBMITTALS

- A. The following information shall be submitted to the Engineer in accordance with the provisions of the Submittals section. The material shall be submitted not less than 6 weeks prior to startup.
 - 1. Lesson plans, training manuals, handouts, visual aids, and other reference materials for each training session to be conducted by the manufacturer’s representatives.
 - 2. Subject of each training session, identity and qualifications of individuals to be conducting the training, and tentative date and time of each training session.
 - 3. Comprehensive training schedule.

PART 2 – PRODUCTS

2.01 GENERAL

- A. Where specified, the Contractor shall conduct training sessions for the District’s personnel to instruct staff on the proper operation, care, and maintenance of the equipment and systems installed under this contract. Training shall take place at the site of the work and under the conditions specified in the following paragraphs. Approved operation and maintenance manuals shall be available at least 30 days prior to the date schedule for the individual training session.

2.02 LOCATION

- A. Training sessions shall take place at the site of the work at a location designated by the District.

2.03 LESSON PLANS

- A. Formal written lesson plans shall be prepared for each training session. Lesson plans shall contain an outline of the material to be presented along with a description of the visual aids to be utilized during the sessions. Each plan shall contain time allocation for each subject.
- B. One complete set of originals of the lesson plans, training manuals, handouts, visual aids and reference materials shall be the property of the District and shall be suitable bound for proper organization and easy reproduction. The Contractor shall furnish ten copies of necessary training manuals, handouts, visual aids, and reference materials at least one week prior to each training session.

2.04 FORMAT AND CONTENT

- A. Each training session shall include classroom and time at the location of the subject equipment or system. As a minimum, training sessions shall cover the following subjects for each item of equipment or system:
 - 1. Safety
 - a. Review demonstration of safety procedures and related documentation.
 - b. Inspection and discussion of hazardous components of the subject equipment.
 - 2. Familiarization
 - a. Review catalog, parts lists, drawings, etc., which have been previously provided for the plan files and facility operation and maintenance manuals.
 - b. Guided inspection of the subject equipment.
 - c. Demonstration of the subject equipment and how operation in accordance with the specified requirements.
 - 3. Operations and Maintenance Manuals
 - a. O&M manual training sessions shall be held on-site.
 - b. Review of O&M manual content and organization

- c. Update O&M material as required.
- 4. Startup Documentation
 - a. Confirm Manufacturer's certification of proper installation.
 - b. Overview of startup checklist and startup process.
 - c. Explanation of factory and vibration test results.
 - d. Overview of warranty.
- 5. Operation
 - a. Review of subject equipment operations literature and theory of operation.
 - b. Overview of equipment operation and function.
 - c. Explanation and demonstration of all modes of operation including start up, shut down, normal, and emergency operation, and manual and automatic operation through the plant control system.
 - d. Explanation of all hardwired interlocks.
 - e. Explanation and demonstration of equipment related valves and their purpose.
 - f. Explanation of all equipment related instruments including primary element, instrument indicator, purpose, and interpretation of information.
 - g. Check out of District's personnel on proper use of the equipment.
- 6. Preventive Maintenance
 - a. Review preventative maintenance documentation and discussion of maintenance require at various intervals; e.g. daily, weekly, monthly, annually.
 - b. Demonstrate performance of each preventive maintenance task.
 - c. Identification of indicators of equipment problems.
 - d. Discussion of corrosion protection and lubrication requirements.
 - e. Requirements for periodic exercise of equipment and demonstration of equipment exercise where required.
 - f. Identification of inspection points and demonstration of inspection covers removal and routine disassembly and assembly of equipment.
- 7. Corrective Maintenance and Equipment Repair
 - a. Discussion of common repairs and identification of special problems.
 - b. Explanation and demonstration of equipment inspection and troubleshooting.

- c. Demonstration of calibration procedures.
- d. Demonstration of repair procedures where practical.
- e. Troubleshooting.
- 8. Parts
 - a. Discussion of the parts list and ordering of parts.
 - b. Review of spare parts provided with the equipment and identification of other recommended spare part.
 - c. All spare parts to be on-site before commencing with startup and testing.
- 9. Local Representatives
 - a. Name, address, telephone of local representative.
 - b. Review of contact information for providers of routine and emergency repair and operational assistance.

2.05 VIDEO RECORDING

- A. The District shall record each training session and shall retain exclusive rights to each training session recording. The Contractor shall advise all manufacturers providing training sessions that the material will be recorded.
 - 1. Video recordings shall be in the MPEG-4 format.

PART 3 – EXECUTION

3.01 EXECUTION

- A. Training shall be conducted the day after startup is complete in accordance with Section 01910. Training shall not be performed until all equipment is available for regular operation. The Contractor shall arrange to have the training conducted on two, separate non-consecutive days, with no more than 6 hours of class scheduled for any one day. Concurrent classes will not be permitted.

END OF SECTION

SECTION 01910

STARTUP TESTING AND COMMISSIONING

PART 1 GENERAL

1.01 SUMMARY

- A. This section includes the requirements for startup and testing all items of equipment and systems that form a part of this Contract. The purpose of this section is to define the requirements for bringing individual equipment, systems, and facilities online and for proving proper operation and performance of that Work. Contractor is required to develop, submit, and maintain detailed plans, including designation of management and staff, for these activities as specified herein. Additional requirements such as disinfection and training are specified in other sections.
- B. The Contractor is also required to startup, test and commission equipment procured by the District. The Contractor shall refer to the Procurement Documents furnished by District and coordinate with the Supplier of the equipment regarding startup and testing activities.
- C. The startup, testing, and commissioning services referenced or specified herein include the following:
 - 1. Startup and Testing
 - a. Pre-startup checks
 - b. Manufacturer's certification/ Startup support
 - c. Equipment testing
 - 2. Commissioning
- D. Contractor shall request substantial completion documentation from the District after completion of the startup and testing services.

1.02 RELATED SECTIONS.

- A. The WORK of the following Sections applies to the WORK of this Section. Other Sections of the Specifications, not referenced below, shall also apply to the extent required for proper performance of this WORK.
 - 1. Section 01330 Submittal Procedures
 - 2. Section 01310 Construction Project Schedules
 - 3. Section 01550 Bypass Pumping
 - 4. Section 01731 Equipment Operation and Maintenance Manuals
 - 5. Division 11 Equipment
 - 6. Division 13 Special Construction

- 7. Division 15 Mechanical
- 8. Division 16 Electrical
- 9. Division 17 Other

1.03 DEFINITIONS.

- A. Startup and Testing – The transitional phase between completion of construction and start of commissioning.
- B. Pre-Startup Checks – Inspections, tests, point to point and loop checks, and other activities necessary to determine that equipment, and systems and subsystems have been properly manufactured and installed. Pre-startup activities shall include an audit of all factory testing of equipment and compiling the results for comparison to startup and commissioning testing.
- C. Manufacturer’s Certification – A written report signed by a qualified and trained representative of the manufacturer submitted prior to operation, certifying that the equipment is properly installed in accordance with installation instructions. An additional written report signed by a qualified and trained representative of the manufacturer certifying the equipment has been operated under all design and full load conditions and meets the performance criteria and operational requirements in accordance with Specifications and manufacturer’s operating requirements.
- D. Equipment Testing – Follows successful completion of all Pre-Startup Activities and Checks. An initial limited operation of equipment, to demonstrate capability of equipment and installed components to perform their intended functions, respond to controls, and safely interface with external systems, followed by operation of individual systems in manual and automatic mode to test full functionality of individual systems. Test equipment and systems in all applicable modes of operation which may include, but not limited to Manual, Local Automatic, and Remote, with water or other process fluid to simulate normal operating conditions. Test automatic transfer switches with normal and standby power sources. Test medium-voltage and low-voltage switchgear by simulating incoming voltage to the protective devices. For non-process systems, test the functionality of the system using actual conditions (i.e., fire alarm system, access control system, HVAC, battery chargers, automatic transfer switches, uninterruptible power supplies, generators, etc.).
- E. Commissioning – Follows successful completion of all Equipment Testing. Continuous testing of the pump station or lift station facility. During the commissioning, the system under test shall be operated within design conditions reflecting the daily operation of the facility for an uninterrupted period of 14 days.

1.04 CONSTRAINTS

- A. Startup and testing shall be conducted in a manner that does not compromise operation of the existing facility. Any startup and testing activities affecting operation of the existing facilities shall be coordinated with the District and shall be shown on the Project Schedule. The District will cooperate with the Contractor to the extent possible but will have sole authority in decisions affecting existing operations.

- B. Startup and testing shall be conducted during normal working hours during the workweek of Monday through Thursday, unless otherwise approved by the District. Where continuous long-term testing is required, testing may continue over the weekends and holidays with prior approval from the District.
- C. The minimum constraints for startup and testing include the following:
 - 1. Source of water and discharge location during testing, including a closed system in which the flow is recirculated through the station. Coordinate source of water and discharge location with District.
 - a. When required for testing, Contractor shall coordinate with District on temporary piping requirements.
 - 2. Power supply.
 - 3. System redundancy.
 - a. Existing standby facilities shall remain operational and ready for use through the commissioning process in the event of equipment testing issues.

1.05 STARTUP TEAM

- A. The Contractor shall maintain a dedicated startup team led by a startup manager. The individual to be designated as startup manager shall be identified within 45 days of Notice to Proceed and will be reviewed by the District. Once accepted, the Contractor shall not change the startup manager throughout the full period of performance of the Work without written permission of the District. Once engaged in the Project, the startup manager shall attend regular construction progress meetings. No startup activities shall begin until the startup manager has arrived at the jobsite.
- B. The startup manager shall be on Site full time at least 30 days prior to any field startup and testing activities and shall remain on site until all startup, testing, and commissioning activities are complete.
- C. The startup team shall include the startup manager and all staff deemed necessary for successful completion of startup, testing, and commissioning. This will include the District, major equipment vendors, operators, and representatives from the Instrumentation and Control System Supplier. Additional trade representatives may be included as project requirements dictate.

1.05.1 STARTUP MANAGER

- A. The startup manager shall be a startup and testing expert with a minimum of 10 years of experience starting up equipment and systems of similar type, size, capacity, and complexity to the equipment and systems included in this Project. The startup manager shall have the necessary experience to fully understand all startup requirements, to manage the Contractor’s resources providing the startup services, and to prepare all startup documentation, as specified. The startup manager’s assigned duties and responsibilities are those specifically related to planning, supervising, and executing startup activities and shall include, but shall not be limited to the following:

MOULTON NIGUEL WATER DISTRICT

1. Coordinating all testing and startup activities.
2. Preparing all startup and field-testing plans, documentation, and forms.
3. Liaising between the Contractor and District for all startup and testing activities.
4. Developing a comprehensive plan and schedule for all startup activities and providing regular schedule updates. The startup and testing schedule shall be incorporated into the Progress Schedule.
5. Scheduling and leading startup, testing, and commissioning planning workshops.
6. Conducting coordination meetings during startup, testing, and commissioning at least weekly.
7. Coordinating manufacturers' services and their certification of proper installation and/or operation of equipment as required by the Specifications.
8. Overseeing and administering all startup, testing, and commissioning activities, including either direct participation in the activities and/or oversight and monitoring of activities. It shall be the startup manager's responsibility to assure that all tests have been completed in accordance with accepted testing procedures.
9. Ensuring readiness for and coordinating maintenance, repair, and adjustment of equipment and systems during startup testing, and commissioning.
10. Conducting or overseeing pre-test checks to ensure readiness for testing.
11. Verify all piping hydrostatic testing and flushing has been completed prior to field testing connected equipment.
12. Ensuring all testing equipment is in proper working order and has been calibrated to appropriate standards.
13. Developing safe work policies and procedures including lockout/tagout procedures and personal protective equipment policies, which will be followed during all field startup and testing activities. At a minimum the Contractor shall comply with OSHA and the District's established safety guidelines. It shall be the startup manager's responsibility to assure all safety procedures are followed at all times.
14. Reviewing and approving all equipment training sessions prior to submission to District, to assure that the training is compliant with the requirements of the Specifications and includes all applicable operation, maintenance, safety, functional, performance, and startup and testing information.
15. Organizing teams made up of qualified representatives of Suppliers, Subcontractors, and others, as appropriate, to efficiently and expeditiously startup and test the equipment and systems installed and constructed under this Contract. The objective of this program shall be to demonstrate to the District that the structures, systems, and equipment constructed and installed under this Contract meet all performance requirements and the

facility is ready for operation as intended. In addition, the testing program shall produce baseline operating conditions for the District to use in a preventive maintenance program.

16. Ensuring the development and maintenance of records documenting all startup, testing, and commissioning activity. The records shall be organized by major process system into organized files/binders and turned over to the District prior to applying for final payment. Testing records shall be accessible to the District at all times to allow monitoring of the progress.
17. Ensuring the startup team is equipped and ready to make emergency repairs and adjustments to equipment installed and modified as part of the Project.
18. Scheduling and conducting a one-day workshop with the District to resolve submittal review comments to the Contractor's startup, testing, and commissioning plan submittal.
19. Notifying the District and all respective equipment manufacturers at least 21 days prior to the date when each equipment system is scheduled for pre-startup activities and checks.
20. Organize InterNational Electrical Testing Association (NETA) acceptance testing in accordance with the Electrical Equipment Installation section.

1.05.2 MANUFACTURER'S FIELD SERVICES REPRESENTATIVE

- A. The manufacturers shall provide a technically qualified field-service representative for the installation, startup, and testing of equipment furnished, as specified in the equipment sections and the Procurement Documents. The manufacturer shall submit qualifications and experience records for all key personnel to be involved in startup activities.
- B. The manufacturer's field services representative shall be on-call during commissioning described in Section 3.03.
- C. The manufacturer's field services representative shall be employed full-time in installation, startup, and testing of similar equipment and facilities and work directly for the manufacturer. The representative shall have conducted startup activities similar to those required herein on at least two other projects of similar complexity. The District shall have the right to reject the manufacturer's field services representative at any time, for immediate replacement by the manufacturer, if the accepted qualifications are not representative of the actual experience or abilities of the representative, as determined by the District.
- D. The manufacturer's field services representative shall provide on-site support as specified in the appropriate equipment specification, including specified in individual equipment testing, or for two non-consecutive days, whichever is greater.

1.06 SUBMITTALS

- A. Contractor shall submit the following information in accordance with the requirements of the Submittals Procedures section.
 - 1. Startup manager’s qualifications and past project experience including contact names, addresses and current telephone numbers of District representatives that can be used to verify the accuracy of the information. Submittal shall be made at the preconstruction conference.
 - 2. Manufacturers’ field services representative’s qualifications and past project experience including contact names, addresses and current telephone numbers that can be used to verify the accuracy of the information. Qualification submittals shall be made at least 6 weeks before the manufacturer’s representative is scheduled to be on Site.
 - 3. Manufacturer’s certification of proper installation and operation of all equipment as specified in the equipment sections after equipment installation and commissioning.
 - 4. Startup Schedule and Startup Commissioning Plans
 - a. Plans and schedules shall be developed to facilitate coordinated and efficient startup, testing, and commissioning of the Project equipment and systems in accordance with this section and Section 1.07.
 - 5. Startup Plan
 - a. Equipment and system startup, testing, and commissioning plans and schedules in accordance with the requirements of this section and Section 1.08. Startup manager shall coordinate with Subcontractors and include their information in the startup and testing plan.
 - 6. Startup Checks Plan
 - a. Plan in accordance with Section 1.09.
 - 7. Equipment Testing and Equipment Acceptance Testing Plan
 - a. Plan in accordance with Section 1.10.
 - 8. Reports and Records
 - a. Reports and records in accordance with Section 1.11.
 - 9. Unless otherwise specified in the equipment sections, preliminary copies of field calibration results. Submittal shall be made prior to the start of each test for associated systems.
 - 10. Daily logs.
 - 11. Letter verifying completion of all startup activities including receipt of all specified items from manufacturers or suppliers. The letter shall include startup checklists indicating that the equipment is in compliance with the Manufacturer’s operating parameters and the requirements of the individual equipment specifications. A generic startup checklist is provided at the end of this specification. An electronic copy of the form will be furnished upon request from the District.

1.07 STARTUP SCHEDULE AND STARTUP COMMISSIONING PLANS

- A. A startup schedule that provides an overall sequence and duration for all startup, testing and commissioning activities, shall be prepared and maintained. This schedule shall serve as a companion to but shall not be a replacement for the startup plan. The startup schedule described in this section shall be integrated into the overall Progress Schedule and shall be prepared as specified for the Progress Schedule in the Construction Progress Schedule section. The Startup Schedule shall be updated weekly during the startup, testing, and commissioning period.
- B. The Contractor shall submit a startup, testing, and commissioning plan and schedule to the District no later than 90 calendar days prior to the commencement of startup and testing. A minimum of 21 days shall be allowed for review by District. The schedule and plan must be accepted a minimum of 30 days prior to commencement of startup and testing. The schedule and plan shall include sections for startup checks, equipment testing, and operational acceptance testing.
- C. Forms for startup and testing shall include identification of equipment or system, startup/test date, nature of startup/test, startup/test objectives, startup/test prerequisites, startup/test results, instruments employed for the startup/test and signature spaces for the District's witness (where applicable) and the Contractor's startup manager.

1.08 STARTUP PLAN

- A. The Startup Plan shall include the following:
 - 1. Introduction with a narrative description of the overall testing and startup program. The description shall include all contractual or regulatory treatment requirements to be demonstrated.
 - 2. A summary of the objectives and approach for startup checks, equipment testing, and operational acceptance testing.
 - 3. List of the instruments, equipment, and systems that will undergo startup and testing with references to the appropriate PIDs, equipment tags/identification numbers, Specification number and standards for testing procedures.
 - 4. Schedule for startup and field testing for each instrument, piece of equipment (including redundant equipment), and system.
 - 5. Safety and emergency response plan including a list of emergency and non-emergency contacts (email and phone).
 - 6. Organization chart for Contractor's startup and testing personnel with assigned responsibilities for each.
 - 7. Startup and testing record keeping plan.
 - 8. Plan for reuse and disposal of water/wastewater from startup, testing, commissioning including information on any required regulatory permits/approvals.

9. Plan and methodology for providing temporary power (when required).
 10. Description of temporary facilities that will be provided.
 11. List of chemicals to be provided by the District.
- B. Within 7 to 14 days of initial submittal of the startup plan, the Contractor shall schedule a workshop with the District to present the plan. The Contractor shall submit minutes of the workshop, including action items and a schedule for updating the startup plan, to the District within 3 days of the workshop.
- C. Individual plans for each phase of startup, testing, and commissioning can be assembled as chapters in the startup plan or submitted as individual documents but should be correlated to ensure there is not disagreement between chapters or separate documents.

1.09 STARTUP CHECKS PLAN

- A. The startup checks plan shall be subdivided into plans for each system and major component. Each system/major component plan shall include but not be limited to the following:
1. Identification of information for each component or piece of equipment to be inspected as part of the system. All applicable tag numbers shall be included.
 2. Specific activities to be completed on each component, piece of equipment, or system as required to demonstrate proper installation and connection.
 3. A tracking checklist of prerequisites for the checks and each step of the checking procedure, including any temporary facilities or utility requirements.
 4. Listing of manufacturer's representative(s) to be on site during the check.
 5. Sign off forms for the Contractor's startup manager.

1.10 EQUIPMENT TESTING AND EQUIPMENT ACCEPTANCE TESTING PLANS

- A. The equipment acceptance testing plan shall include procedures and reporting for functional testing. The equipment acceptance testing plan shall be subdivided into testing plans for each system. Each system test plan shall include but not be limited to the following:
1. A narrative description of the purpose and goals of the test for each component, piece of equipment, or system, which should include all activities (including those required by vendors/suppliers) necessary to verify proper equipment and system functionality.
 2. Identification of each component or piece of equipment to be tested as part of the system. All applicable tag numbers shall be included.
 3. Schedule and duration for the tests.
 4. Prerequisites for each test, including any temporary facilities or utility requirements.
 5. Pass/fail criteria for the test.

6. A checklist for tracking testing progress which includes prerequisites for the test and each step of the testing procedure. The check list shall include specified performance criteria that are to be met.
7. A description of test apparatus required to conduct the test.
8. Identification of all temporary facilities and chemicals require during startup.
9. Listing of manufacturer's representative(s) to be on site during the test.
10. Certificates of proper installation, as applicable to the test.
11. Step-by-step detailed procedure of the test. The level of detail shall be sufficient for a witness to be able to follow the steps during the test and be confident that the test is being performed as planned. All steps required to proceed through the test in an orderly manner are considered significant and each of these steps shall be included in the procedure.
12. Copies of the data recording forms that will be used during the test.
13. Calculation methodologies to be used to evaluate the data and/or test criteria for the test.
14. Sample computations or analyses for the test with results in the same format as the final report. This item is intended to demonstrate how data collected will be used to generate final results. A sample shall be included for each type of computation required for the test and analysis of results.
15. Blank sign-off forms for the test acknowledging the startup manager's, District's, and equipment manufacturer's acceptance of the test where applicable.
16. An Equipment Testing outline is provided at the end of this specification as an example that that may be used to generate a complete Equipment Testing plan that covers the design parameters and the requirements of the testing.

1.11 REPORTS AND RECORDS

- A. The contractor may utilize the Startup And Testing Process And Checklist to monitor and track the completion of all startup and testing plan submittals and activities and verify all items are complete prior to moving to the next phase.
- B. Records of all startup and testing shall be compiled by the Contractor and submitted to the District. Prior to being submitted to the District, the startup manager shall certify that the recorded results and the systems tested comply with the Contract requirements. Records shall include all documentation assembled for each piece of equipment or system involved in the startup and testing, including all certifications, forms, and check lists completed during the startup and test, and sign-off forms. A generic startup checklist is provided at the end of this specification that may be used to document that equipment is in compliance with the manufacturer's operating parameters and the requirements of the individual equipment specifications.

- C. Records of all startup and testing shall be compiled as separate documents for each system tested and shall be submitted within 48 hours of completion of the startup and testing for each system. Testing samples that require analysis periods greater than 48 hours shall be clearly defined in the startup plan but shall not preclude delivery of the balance of the records within the 48-hour timeframe.
- D. The Contractor shall provide formal reporting and documentation of failures, malfunctions or defects, and repairs made during the startup and/or testing activities. A “System Problem Report” form is included at the end of this section and shall be used by the Contractor to document problems that arise during these tests and their resolution. Records submitted shall include “System Problem Report” forms completed during testing.

PART 2 – PRODUCTS

2.01 GENERAL

- A. The Contractor shall provide all materials, instruments, incidentals, temporary facilities and equipment required for startup, testing, and commissioning activities on-site prior to commencing startup. Temporary facilities required to carry out the specified testing, including temporary pipe, pumps, and other appurtenances, shall be furnished and installed, and subsequently removed when no longer required. All water required for, and in connection with the Work to be performed, shall be furnished by and at the expense of Contractor through meters installed on hydrants. Contractor shall supply all necessary tools, hose, and pipe, or otherwise transport the water to the point of use and shall make its own arrangements with the District as to the amount of water required and the time when the water will be needed. Indiscriminate use of water so furnished will not be permitted. Special hydrant wrenches shall be used for opening and closing fire hydrants. In no case shall pipe wrenches be used for this purpose. Contractor shall provide all power for heating, lighting, operation of Contractor's plant or equipment, or for any other use by Contractor. Temporary heat and lighting shall be maintained until the Work is accepted. Chemicals required for startup and testing will be provided by the District. Contractor shall give the District 45 days notice before chemicals are required except as otherwise specified herein. Wastewater, including treated or test water shall be disposed of at the expense of the Contractor, in a manner acceptable to the District, and in accordance with all laws, regulations, and permits.

PART 3 – EXECUTION

3.01 PRE-STARTUP CHECKS (DRY SIMULATION)

- A. Prior to field testing of all equipment, the Contractor shall perform the following:
 - 1. Provide working as-built drawings and / or redlines of electrical drawings associated with the equipment being tested prior to commencing startup activities.
 - 2. Inspect and clean equipment, devices, and connected piping so they are free of foreign material.
 - 3. Lubricate equipment in accordance with manufacturer’s instructions.
 - 4. Turn rotating equipment by hand.

5. Open and close valves by hand and operate other devices to check for binding, interference, or improper functioning.
 6. Test and commission related electrical system components in accordance with the requirements specified in the Electrical and the Electrical Equipment Installation sections, including completion of point to point and loop testing.
 7. Calibrate all instruments associated with the equipment.
 8. Check for proper rotation, adjustment, alignment, balancing, mechanical and electrical connections, and any other conditions that may damage or impair equipment from functioning properly.
 9. Inspect and verify proper anchorage.
 10. Obtain manufacturer's certification of proper installation where specified in the equipment sections.
 11. Verify all I/O signals to/from the field device, motor starters, or control panels, through all cabling, to the PLC, operator interface terminal (OIT), and human machine interface (HMI) and the application software properly operates.
- B. All equipment shall be confirmed ready to test by the District based on the following:
1. Acceptance of Contractor's startup and testing plan.
 2. Notification in writing by the startup manager that each piece of equipment or system is ready for testing.
 3. Verification by the District that all lubricants, tools, maintenance equipment, spare parts and approved equipment operation and maintenance manuals have been furnished as specified.
 4. Cleanliness of equipment, devices, and connected work.
 5. Adequate completion of work adjacent to or interfacing with equipment to be tested.
 6. Confirmation of manufacturer's representative's availability to assist with testing, where specified, and satisfactory fulfillment of all other manufacturers' responsibilities as specified.
 7. District's inspection of all related civil construction, mechanical, and electrical installations.
 8. Confirmation of completion of acceptable testing of all adjacent piping, duct work and other affected Work.
 9. Proper installation, operation, and adjustment of all devices, instrumentation, and equipment on a loop-by-loop and component-by-component basis. Functionality shall be checked from the primary element in the field through all cabling to the PLC and

HMI.

10. Proper operation of equipment controls, devices, and indicating lamps.
11. All hardwired interlocks properly shutdown the equipment.
12. All alarms are triggered at the HMI/OIT and SCADA.
13. All status signals are monitored at the HMI/OIT and SCADA.

3.02 EQUIPMENT TESTING

- A. All pre-startup checks shall be completed successfully with the manufacturer's certification of approval prior to functional testing of the equipment. Testing of the equipment shall be in accordance with relevant standards and in accordance with instructions of the manufacturers and shall be contractor witnessed and verified.
- B. Equipment testing shall include the functional operation of each piece of equipment. All moving parts of equipment and machinery shall be tested and adjusted so that they move freely and function satisfactorily. Equipment testing shall demonstrate correct operation of all hardwired interlocks and controls.
- C. Once testing of individual pieces of equipment is completed, individual systems functional testing shall commence, when required. Individual system functional testing shall include startup of the complete system of mechanical, electrical, and instrumentation and control equipment as a functional process system. Field inspection prior to startup as specified in the Instrumentation and Control System section, other testing by the Instrumentation and Control System Supplier required to verify readiness for automatic operation of the individual system, shall be completed before commencement of individual system functional testing. The manufacturer's representative shall be on-call during acceptance testing or on-site if specified in the equipment specifications. The equipment shall test and document that all equipment and systems are properly operated and controlled in the Manual, Auto, Remote and Local modes as intended using contractor developed test procedures. This test is accomplished with the lift station or pump station system online through full range of normal operating conditions. Equipment will operate under load with water when possible or the designed process media (e.g. air, gas, etc.).
- D. Individual system functional testing shall include operation in manual and automatic modes, startup operation, and shutdown in normal and emergency modes. Individual systems shall be tested over their entire operating range and for sufficient time to demonstrate the intended functionality of each piece of equipment and the system. If any part of a system shows evidence of unsatisfactory or improper operation during the test period, correction or repairs shall be made and the functional testing shall be repeated until satisfactory results are obtained.
- E. Functional testing of all process and pumping equipment and drive motors, including auxiliary equipment, shall be in accordance with the appropriate and approved test codes, such as those specified by the American Society of Mechanical Engineers, Hydraulic Institute Standards, and IEEE.

- F. Qualified personnel from the electrical and mechanical trades responsible for installation of the equipment, shall be available during functional testing involving electrically operated equipment. Where appropriate, a representative of the Instrumentation and Control System Supplier shall also be available.
- G. Equipment testing shall be District supervised and approved.
- H. The Equipment Testing shall include the following submittals prior to commencement:
 - 1. Prerequisite checklist, to be acknowledged by the District prior to initiating the test, which demonstrates that all testing and other Work required to be completed prior to the test is complete.
 - 2. Listing of District 's personnel necessary to operate the system and conduct any related monitoring of performance.
 - 3. A listing of Contractor's personnel designated to supervise and advise the District's operators as required herein.
 - 4. Listing of standby personnel, equipment, and materials that will be available if needed during the test period.
 - 5. Step-by-step procedures for operation of the facility showing how local and remote control of equipment will be demonstrated. Including a description on how each flow rate condition will be accomplished.
 - 6. Description of all data and other information to be reported in support of the completed test. Include any blank data logs that may be used for recording results.
 - 7. Descriptions of all necessary calculations that must be completed to verify the specified results are being achieved, including formulas.
 - 8. Blank sign-off form for the test acknowledging the Contractor's, District's, and the equipment manufacturer's acceptance of the test.
- I. Contractor shall provide District 14 days' notice prior to testing of any individual system.
- J. Individual system acceptance testing shall continue for 48 hours or until system is deemed functional by the District and without interruption for each system, and all parts shall operate satisfactorily in all respects under a range of conditions to simulate the full operating range of the equipment or system and all I/O conditions functions.
- K. If any part of a system shows evidence of unsatisfactory or improper operation during the testing period, correction or repairs shall be made and the test repeated until the test is successfully completed. Testing interrupted by power failure will not be required to be repeated, but the test shall be continued upon restoration of power and extended to the specified duration at no additional cost to the District.
- L. Testing shall be conducted with flows that comply with the District's requirements for lift stations and booster pump stations.

1. Booster pump station testing shall be conducted with clean drinking water.
2. Lift station testing shall be conducted with recycled water.

3.03 COMMISSIONING

- A. At the completion of the equipment tests, commissioning of the complete facility constructed or modified under the Contract shall be conducted. Commissioning shall not be conducted concurrently with other individual system acceptance or performance tests.
- B. The test shall run at least 14 days, unless noted otherwise, with the entire facility operating in the intended manner. The test shall demonstrate to the satisfaction of the District that the facilities are complete and meet all specified requirements and can be continuously operated for their full intended function. During the testing period, facility shall operate under all control modes, including manual, remote-manual, and automatic. The District's staff shall operate the facility during this phase.
- C. Duty and standby equipment shall be alternated so that all equipment is selected for duty operation for a period of at least 2 days during the test. Unless indicated otherwise, if any item malfunctions or a defect is found during the test, the item shall be repaired and the test either extended a duration to be determined by the District depending on the severity of the malfunction or defect, or restarted at time zero with no credit given for the operating time before the malfunction or the defect was found. Any malfunction that causes interruption to the operation of the facility and does not have standby equipment that can be placed into service will require a complete restart of the 14-day commissioning duration.
- D. Facilities where bypass systems are required shall leave bypass equipment installed in its fully operational condition, on-site, until commissioning is complete.
- E. All malfunctions, defects in materials or workmanship, or other flaws, which appear during this test period, shall be immediately corrected by the Contractor. If spare parts from the specified spare parts inventory are used to make repairs, they shall be replaced immediately and must be replaced prior to application for final payment.
- F. The Contractor shall supply all fuel, oil, grease, lubricants, and ancillary equipment required for commissioning.
- G. All facility control system coordination issues shall be resolved, and data trending requirements shall be functional during this period.
- H. The facility shall be operated in accordance with the operating permit, laws, and regulations during commissioning. The Contractor shall provide mechanics, electricians, and controls technicians during commissioning as required for troubleshooting and repair.

STARTUP AND TESTING PROCESS AND CHECKLIST

The following tables are sample checklists that are provided as guidelines. Contractor shall modify checklists as needed for each project and equipment.

Pre-Startup Checks:

Equipment System or Item	Equipment Tag Numbers	Submittal Completion	Factory Demonstration Tests (FDT) & Witnessed Factory Demonstration Tests If applicable				Anchorage (Seismic) Requirements Calculation Submittal	Mechanical (Divisions 11, 13, 14, & 15)					Electrical (Division 16)				PLC programming	Operating Permits
			FDT Procedures Submittal	FDT Results Submittal	WFDT Start Date	WFDT Results Submittal		Factory Performance Test Report	Mechanical Alignment Report	Manufacturer Certificate of Proper Installation	Metallurgical Report	Pipe Pressure Test Report	Manufacturer Certificate of Proper Installation	NETA Reports	Motor Test by CONTRACTOR (3 to 20hp)	Motor Test by NETA (>=20hp)		
Equipment #1	###	[Date]	[Date]	[Date]	[Date]	[Date]	Received Yes/No	Received Yes/No	Received Yes/No	[Date]	[Date]	[Date]	[Date]	[Date]	[Date]	[Date]	[Date]	

Pre-Startup Checks (Continued):

Electrical Room HVAC Complete	Request approval to Energize Electrical Equipment by District	Electrical Equipment Testing	Electrical Commissioning	Instrumentation Calibration	Manufacturer Certification of Proper Operation	Startup Checks Plan Complete
[Yes/No]	[Yes/No]	[Date]	[Date]	[Date]	[Date]	[Date]

Equipment Testing:

Equipment System or Item	Equipment Tag Numbers	Pre-Startup Checks Complete	Equipment Testing	Field Performance Tests by Contractor
Equipment #1	###	[Date]	[End Date]	[End Date]

Commissioning:

Equipment System or Item	Equipment Tag Numbers	Commissioning Dates	Manufacturer Certification of Proper Operation	Substantial Completion
Equipment #1	###	[Start Date] – [End Date]	[Date]	[Date]

STARTUP CHECKLIST

PROJECT NAME: _____

PROJECT NUMBER: _____

Report Status:

Startup check completed and submitted on _____

Description

A. Equipment Name and Identification: _____

B. Asset ID: _____

C. Serial Number: _____

D. Specification Section Number: _____

E. Manufacturer: _____

F. Representative: _____

General Review

A. The above referenced equipment/material/supplies have been inspected, checked, and adjusted. Yes ___ No ___

Summary: _____

B. The above referenced equipment/material/supplies were placed upon properly prepared or suitable substrate and anchored appropriately.

N/A _____ Yes ___ No ___

Summary: _____

C. The above referenced equipment/material/supplies are free from any undue stress imposed by any connected piping, anchor bolts or any other load.

N/A _____ Yes ___ No ___

Summary: _____

- D. Storage and maintenance prior to being placed into service have been verified to be in compliance with contract documents and manufacturer's recommendation. Attach certification of such from manufacturer along with any supporting documentation required by the manufacturer to verify compliance. N/A _____ Yes _____ No _____

Summary: _____

- E. The above referenced equipment/material/supplies have operated under design conditions. N/A _____ Yes _____ No _____

Summary: _____

- F. The above referenced equipment/material/supplies have been installed in accordance with the manufacturer's recommendations and the Procurement Documents, require no corrective work, and are hereby ready to be placed into service. Yes _____ No _____

Summary: _____

- G. The above referenced equipment/material/supplies are ready to be placed into service according to the manufacturer as installed providing the following corrective action(s) are performed:

1. _____

2. _____

3. _____

4. _____

SYSTEM PROBLEM REPORT

Project Name: Insert Project Name			
Test Name:			
Test Number:			
Problem Type: Hardware Software Documentation Unknown Other			
SYMPTOMS:	Time:	Date:	By:
Description:			
Can problem be reproduced at will? Y / N			
DIAGNOSIS:	Time:	Date:	By:
Description:			
CORRECTION:	Time:	Date:	By:
Description:			
FINAL SIGN OFF	Time:	Date:	By:

END OF SECTION

SECTION 02200

EARTHWORK

PART 1 GENERAL

1.01 SECTION INCLUDES

- A. Excavation, backfilling, materials, testing, and shoring for structures and site earthwork

1.02 RELATED REQUIREMENTS

- A. Section 02223, Trenching, Backfilling, and Compacting
- B. Section 03300, Concrete
- C. Section 03461, Precast Reinforced Concrete Manholes
- D. Section 03462, Precast Concrete Vaults
- E. Section 03463, Grease Interceptors

1.03 DEFINITIONS

- A. Pavement and street zones: as specified in Section 02223
- B. Upper Backfill Zone: The upper backfill zone is defined as the backfill to the full width of the excavation from the top of the structure to the bottom of the street zone in paved areas or to the finished surface in unpaved areas.
- C. Structural Backfill Zone: The structural backfill zone is defined as the backfill from the top of the structure to the bottom of the excavation, extending the full width of the excavation.
- D. Over-excavation: excavation below the design subgrade depth
- E. Geotechnical Engineer: The Geotechnical Engineer provided by the District or agency having jurisdiction, unless stated otherwise

1.04 REFERENCED STANDARDS

- A. California Division of Occupation Safety and Health (Cal/OSHA)
 - 1. Cal/OSHA Sub-chapter 4, Article 6: Excavations

1.05 SUBMITTALS

- A. Submit drawings of excavation and shoring, sheeting or bracing for worker protection in accordance with the General Provisions.
- B. Submit six (6) copies of a report from a testing laboratory verifying that gravel base and structural backfill conforms to the specified gradations or characteristics.

- C. Test reports on borrow material
- D. Other tests and material reports as required

1.06 PERMITS

- A. Obtain permit with the California Division of Occupational Safety and Health where trenches or excavations exceed 5-feet deep.
- B. All work shall conform to the specifications and requirements of the State of California Department of Transportation, the Orange County Public Works, the city having jurisdiction, and other agencies involved.
- C. The Contractor shall keep a copy of all the required permits in the job site and comply with all the terms and conditions of said permits.

PART 2 PRODUCTS

- A. Native earth backfill, imported backfill material, granular material, imported sand, and crushed rock shall conform to the requirements of Section 02223.

PART 3 EXECUTION

3.01 PREPARATION

- A. Conform to requirements of Section 02223.

3.02 DE-WATERING

- A. Conform to requirements of Section 02223.
- B. Provide and maintain means and devices to continuously remove and properly dispose of all water entering the excavation during construction of the structure and all backfill operations.
- C. Do not allow water to rise in the excavation until backfilling around and above the structure is completed.

3.03 STRUCTURE EXCAVATION

- A. Structure excavation shall include the removal of all material of whatever nature necessary for the construction of structures and foundations in accordance with the plans, these specifications, and the geotechnical report.
- B. The sides of excavations for structures shall be sufficient to leave at least a 2-foot clearance, as measured from the extreme outside of form work or the structure, as the case may be.
- C. Surplus material shall be disposed of by the Contractor in accordance with Section 02223.

D. Over-Excavation:

1. Over-excavate below subgrade per the requirements of the geotechnical report.
2. Inadvertent Over-Excavation
 - a. Where excavation is inadvertently carried below design depths, suitable provision shall be made by the Contractor to adjust construction, as directed by the District, to meet requirements incurred by the deeper excavation.
 - b. Native backfill will not be permitted to correct over-excavation beneath structures.
 - c. Over-excavation shall be corrected by backfilling with ¾" crushed rock or concrete, as directed by the District.

3.04 SHEETING, SHORING, AND BRACING

- A. Conform to requirements of Section 02223.
- B. The sheeting, shoring, and bracing shall be arranged so as not to place any stress on portions of the completed work.

3.05 BACKFILL

- A. After structures and foundations are in place, backfill shall be placed to the original ground line or to the limits designated on the plans and in accordance with the geotechnical report.
- B. No material shall be deposited against concrete structures until the concrete has reached the 28-day compressive strength as tested per Section 03300. Where backfill is to be placed on both sides of the wall, the backfill shall be placed uniformly on both sides. Where backfill is to be placed around a structure, the backfill shall be placed at a uniform rate around the structure.
- C. Backfill shall not be placed against the walls of structures that are laterally restrained or supported by suspended slabs or slabs on grade until the slab is poured and the concrete has reached the specified compressive strength.
- D. Imported sand or granular material shall be placed in horizontal layers not exceeding 12 inches in depth.
- E. Excavations shall be backfilled as work permits, but not until completion of the following:
 1. Acceptance of construction below finish grade including, where applicable, damp proofing, waterproofing, and perimeter insulation
 2. Inspection, testing, approval, and recording locations of underground utilities
 3. Removal of concrete formwork
 4. Removal of shoring and bracing, and backfilling of voids with satisfactory materials. Cut off temporary sheet piling driven below bottom of structures and remove in manner to prevent settlement of the structure or utilities, or leave in place, if required.
 5. Removal of trash and debris
 6. Permanent or temporary horizontal bracing is in place on horizontally supported walls.

3.06 COMPACTION REQUIREMENTS

- A. Minimum compaction requirements are as follows. Requirements of the jurisdictional agency govern.
 - 1. Backfill in street zone: 90% relative compaction
 - 2. Structural backfill: 90% relative compaction
 - 3. Gravel base: 90% relative compaction
 - 4. Adjacent to existing structures: 95% relative compaction
 - 5. Under new structures: 95% relative compaction
 - 6. Rock refill for over-excavation: 90% relative density
- B. Each layer of backfill material shall be moistened and thoroughly tamped, rolled, or otherwise compacted to the specified relative density.
- C. Carefully operate compaction equipment near structures to prevent their displacement or damage. Structural fill is to be placed and compacted in uniform layers around all sides of the structure.

3.07 RESTORATION

- A. Pavement replacement shall be in accordance with the requirements of the city or the agency having jurisdiction.

3.08 TOLERANCES FOR SITE EARTHWORK

- A. Top surface of subgrade: 1/2-inch from specified grade

3.09 FIELD QUALITY CONTROL

- A. All grading, excavation, backfill, and compaction, shall be performed under inspection by a California licensed Geotechnical Engineer.
- B. Testing for compaction shall conform to Section 02223.

END OF SECTION

SECTION 02223

TRENCHING, BACKFILLING, AND COMPACTING

PART 1 GENERAL

1.01 SECTION INCLUDES

- A. Trench excavation, backfilling, and compacting

1.02 RELATED REQUIREMENTS

- A. Section 02200, Earthwork
- B. Section 15056, Ductile Iron Pipe and Fittings
- C. Section 15057, Copper, Brass, and Bronze Pipe Fittings and Appurtenances
- D. Section 15064, PVC Pressure Distribution Pipe
- E. Section 15066, Gravity Sewer Pipelines
- F. Section 15068, Sewer Laterals

1.03 DEFINITIONS

- A. Pipe Zone: The pipe zone shall include the full width of trench from the bottom of the pipe or conduit to a horizontal level 12 inches above the top of the pipe.
- B. Pipe Bedding: The pipe bedding shall be defined as a layer of material immediately below the bottom of the pipe or conduit and extending over the full trench width in which the pipe is bedded. Thickness of pipe bedding shall be as shown on the drawings or as described in these specifications for the particular type of pipe installed.
- C. Over-excavation: Excavation below the design subgrade depth
- D. Geotechnical Engineer: The Geotechnical Engineer provided by the District or agency having jurisdiction, unless stated otherwise

1.04 REFERENCED STANDARDS

- A. ASTM International
 - 1. ASTM D75: Standard Practice for Sampling Aggregates
 - 2. ASTM D1556: Standard Test Method for Density and Unit Weight of Soil in Place by Sand-Cone Method
 - 3. ASTM D1557: Standard Test Methods for Laboratory Compaction Characteristics of Soil Using Modified Effort

4. ASTM D2937: Standard Test Method for Density of Soil in Place by the Drive-Cylinder Method
 5. ASTM D4254: Standard Test Methods for Minimum Index Density and Unit Weight of Soils and Calculation of Relative Density
 6. ASTM D6938: Standard Test Methods for In-Place Density and Water Content of Soil and Soil-Aggregate by Nuclear Methods (Shallow Depth)
- B. California Department of Transportation (Caltrans)
1. Test 217, Method of Test for Sand Equivalent
- C. California Division of Occupation Safety and Health (Cal/OSHA)
1. Cal/OSHA Sub-chapter 4, Article 6: Excavations

1.05 SUBMITTALS

- A. Data sheets for all materials
- B. Certificates that materials meet requirements of this specification
- C. Drawings of excavation and shoring, sheeting or bracing
- D. Calculations

1.06 PERMITS

- A. Obtain permit with the California Division of Occupational Safety and Health where trenches or excavations exceed 5-feet deep.
- B. All work shall conform to the specifications and requirements of the State of California Department of Transportation, the Orange County Public Works, the city having jurisdiction, and other agencies involved.
- C. The Contractor shall keep a copy of all the required permits on the job site and comply with all the terms and conditions of said permits.

PART 2 PRODUCTS

2.01 NATIVE EARTH BACKFILL

- A. The use of native earth as backfill material will require the acceptance of the District in all cases.
- B. Native earth backfill, acceptable for use, shall be fine-grained material free from roots, debris, and rocks with a maximum dimension not larger than 3 inches.
- C. Native backfill shall not be used in the pipe zone.

2.02 IMPORTED BACKFILL MATERIAL

- A. Whenever the excavated material is not suitable for backfill, the Contractor shall arrange for and furnish suitable imported backfill material that is capable of attaining the required relative density.
- B. The Contractor shall dispose of the excess excavated material as specified in this section. Backfilling with imported material shall be done in accordance with the methods described herein.

2.03 IMPORTED SAND

- A. Imported sand shall have a minimum sand equivalent of 30 per Caltrans Test 217 with 100% passing a 3/8 inch sieve and not more than 20% passing a 200-mesh sieve.

2.04 CRUSHED ROCK AND GRAVEL

- A. Crushed rock shall be the product of crushing rock or gravel. Fifty percent of the particles retained on a 3/8 inch sieve shall have their entire surface area composed of faces resulting from fracture due to mechanical crushing. Not over 5% shall be particles that show no faces resulting from crushing. Less than 10% of the particles that pass the 3/8 inch sieve and are retained on the No. 4 sieve shall be weatherworn particles. Gravel shall not be added to crushed rock.
- B. Gravel shall be defined as particles that show no evidence of mechanical crushing, are fully weatherworn, and are rounded. For pipe bedding, where gravel is specified, crushed rock may be substituted or added.
- C. Where crushed rock or gravel is specified in the bedding details on the plans, the material shall have the following gradations:

Sieve Size	¾ Inch Max Crushed Rock % Passing
2"	
1-1/2"	
1"	100
¾"	90-100
½"	30 – 60
3/8"	0 – 20
No. 4	0 – 5
No. 8	-

2.05 SAND CEMENT SLURRY

- A. Sand cement slurry shall consist of one sack (94 pounds) of portland cement per cubic yard of sand and sufficient moisture for workability.

PART 3 EXECUTION

3.01 PREPARATION

- A. Protection of Existing Utilities and Facilities:
 - 1. The Contractor shall be responsible for the care and protection of all existing sewer pipelines, water pipelines, gas mains, storm drains, culverts, or other facilities and structures that may be encountered in or near the area of work.
 - 2. It shall be the duty of the Contractor to notify each agency of jurisdiction and make arrangements for locating each agency's facilities prior to beginning construction.
 - 3. In the event of damage to any existing facilities during the progress of the work due to the failure of the Contractor to exercise the proper precautions, the Contractor shall be responsible for the cost of all repairs and protection to said facilities. The Contractor's work may be stopped until repair operations are complete

- B. Protection of Landscaping
 - 1. The Contractor shall be responsible for the protection of all the trees, shrubs, fences, and other landscape items adjacent to or within the work area, unless directed otherwise on the plans. In the event of damage to landscape items, the Contractor shall replace the damaged items in a manner satisfactory to the District.

- C. Clearing and Grubbing
 - 1. With acceptance by the District and jurisdictional authority, areas where work is to be performed shall be cleared of all trees, shrubs, rubbish, and other objectionable material of any kind which, if left in place, would interfere with the proper performance or completion of the contemplated work, would impair its subsequent use, or would form obstructions therein.
 - 2. Organic material from clearing and grubbing operations will not be incorporated in the trench backfill.
 - 3. Organic material from clearing and grubbing operations will be disposed of at a proper waste disposal facility.

- D. Sidewalk, Pavement, and Curb Removal
 - 1. Saw cut bituminous or concrete pavements regardless of their thickness, and curbs and sidewalks prior to excavation in accordance with the requirements of the city, or agency having jurisdiction. Curbs and sidewalks, that are damaged in the course of construction, are to be cut and removed from joint to joint.
 - 2. Haul removed pavement and concrete materials from the site, to a proper disposal facility. These materials are not permitted for use as trench backfill. The Contractor shall obtain a haul route permit from the city(s), county, or other agencies having jurisdiction.

3.02 DE-WATERING

- A. Provide and maintain means and devices to continuously remove and properly dispose of all water entering the excavations or other parts of the work during excavation and backfill operations.
- B. De-watering shall be done by methods that will ensure a dry excavation and preservation of the final lines and grades of the bottoms of excavations.
- C. De-watering methods may include well points, sump points, suitable rock or gravel wrapped in filter fabric and placed below the required bedding for drainage and pumping, temporary pipelines, and other means, all subject to the acceptance by the District.
- D. De-watering shall commence when groundwater is first encountered and shall be continuous until such times as water can be allowed to rise. No concrete shall be poured in water, nor shall water be allowed to rise around the concrete or mortar until it has set at least eight hours.
- E. Provide the District with 48-hour notice prior to dewatering operations.
- F. Disposal of Water:
 - 1. Disposal of the water shall comply with SWPPP's of City or other agency having jurisdiction, and shall be done in a manner to prevent damage to adjacent property and pipe trenches.
 - 2. Water shall be discharged in accordance with the requirements of the District's NPDES permit. Reporting shall conform to the requirements of the District's NPDES permit. A copy of the District's permit is available from the District.
 - 3. In no event shall the wastewater system be used as a drain for de-watering except with prior acceptance from the District, securing of a special discharge permit from SOCWA, and with District personnel present during the de-watering operations

3.03 ACCESS

- A. Unobstructed access must be provided to all driveways, water valves, hydrants, or other property or facilities that require use.
- B. Barriers shall be placed at each end of all excavations and at such places as may be necessary along excavations to warn all pedestrians and vehicular traffic of such excavations. Lights shall also be placed along excavations from sunset each day to sunrise of the next day until such excavation is entirely refilled.

3.04 TRENCHING

- A. Trench Depth: Excavation for pipe, fittings, and appurtenances shall be open trench to the depth and in the direction necessary for the proper installation of the facilities as shown on the plans.

- B. Trench Width: Excavation and trenching shall be true to line so that a clear space of not more than 8 inches or less than 6 inches in width is provided on each side of the largest outside diameter of the pipe in place measured at a point 12 inches above the top of the pipe. For the purpose of this article, the largest outside diameter shall be the outside diameter of the bell on bell and spigot pipe, or the pipe collar.
- C. Trench Opening:
 - 1. The maximum allowable length of open trench shall be the distance necessary to accommodate the amount of pipe installed in a single day. Within developed areas, the length of open trench may be restricted as determined by the encroachment permit from the city or the agency having jurisdiction.
 - 2. No trench or excavation shall remain open during non-working hours. The trench or excavation shall be covered with non-skid steel plates, tack welded together, spiked in place, or secured with temporary A.C. pavement around the edges, or backfilled or as otherwise required per the City having jurisdiction.
- D. Grade:
 - 1. Excavate the trench to the lines and grades shown on the drawings with allowance for pipe thickness and for pipe base or special bedding.
 - 2. The trench bottom shall be graded to provide a smooth, firm, and stable foundation that is free from rocks and other obstructions. Grade shall be in accordance with plans. Pipes shall be surveyed prior to backfilling to confirm grade.
- E. Foundation Stabilization:
 - 1. Whenever the trench bottom does not afford a sufficiently solid and stable base to support the pipe or appurtenances, the Contractor shall excavate to a depth below the design trench bottom, as directed by the District, and the trench bottom shall be backfilled with 3/4-inch rock and compacted to provide uniform support and a firm foundation.
 - 2. Where rock is encountered, it shall be removed to a depth at least 6 inches below grade and the trench shall be backfilled with 3/4-inch crushed rock to provide a compacted foundation cushion.
 - 3. If excessively wet, soft, spongy, unstable, or similarly unsuitable material is encountered at the surface upon which the bedding material is to be placed, the unsuitable material shall be removed to a depth as determined in the field by the District and replaced by crushed rock.
- F. Over-Excavation:
 - 1. Over-excavate below subgrade per requirements of geotechnical report.
 - 2. Inadvertent Over-Excavation
 - a. Where excavation is inadvertently carried below design depths, suitable provision shall be made by the Contractor to adjust construction, as directed by the District, to meet requirements incurred by the deeper excavation.
 - b. Native backfill will not be permitted to correct over-excavation beneath structures.

- c. Over-excavation shall be corrected by backfilling with $\frac{3}{4}$ " crushed rock or concrete, as directed by the District.

G. Trenchless Construction:

- 1. Tunneling will not be permitted.
- 2. The use of a jack and bore or hydraulic ram may be employed if accepted by the District.

3.05 SHEETING, SHORING, AND BRACING

- A. Design and install bracing and shoring system in conformance with the rules, orders, and regulations of the Cal/OSHA Sub-chapter 4, Article 6.
- B. For any excavation in excess of 5-feet deep, design of sheeting, shoring, bracing, or side slopes shall be performed by a registered Civil Engineer.
- C. Sufficient geotechnical data shall be obtained to provide safe design.
- D. Excavations shall be braced, sheeted, and supported so that they will be safe, such that the walls of the excavation will not slide or settle and all existing improvements of any kind, either on public or private property, will be fully protected from damage. Methods of support or side slopes shall be selected to provide sufficient clearance for public traffic safety and convenience.
- E. The sheeting, shoring, and bracing shall be arranged so as not to place any stress on portions of the completed work.
- F. Carefully remove sheeting, shoring, bracing, and timbering to prevent the caving or collapse of the excavation faces being supported.

3.06 STOCKPILING AND DISPOSAL OF EXCAVATED MATERIAL

- A. All excavated material shall not be stockpiled in a manner that will create an unsafe work area or obstruct sidewalks or driveways. Gutters shall be kept clear or other satisfactory measures shall be taken to maintain the street or other drainage.
- B. In confined work areas, the Contractor may be required to stockpile the excavated material off-site, as determined by the project permits.
- C. Surplus/Excess Excavated Material:
 - 1. The Contractor shall make the necessary arrangements for and shall remove and dispose of all excess excavated material unless indicated differently in the special provisions for any job.
 - 2. It is the intent of these specifications that all surplus material not required for backfill or fill shall be properly disposed of by the Contractor at his expense at a proper disposal site.

3. No excavated material shall be deposited on private property unless written permission from the owner thereof is secured by the Contractor. Before the District will accept the work, the Contractor shall file a written release signed by all property owners with whom they have entered into agreements for disposing excess excavated material, absolving the District from any liability connected therewith.
4. The Contractor shall obtain a haul route permit from the city or agency having jurisdiction.

3.07 PLACING PIPE BEDDING

- A. Place the thickness of pipe bedding material over the full width of trench necessary to produce the required bedding thickness when the material is compacted to the specified relative density. Grade the top of the pipe bedding ahead of the pipe to provide firm, uniform support along the full length of pipe.
- B. Excavate bell holes at each joint to permit assembly and inspection of the entire joint.
- C. Place mounds to support pipe (DIP only):
 1. As an alternate to placing continuous imported sand pipe bedding material, the ductile iron pipe may be supported on mounds of imported sand.
 2. The mounds shall be of imported sand and extend the full trench width. The mounds shall provide a minimum of 6 inches of contact with the pipe.
 3. The pipe shall be supported to maintain its design line and grade.
 4. The mounds shall be located 2½ feet from the bell/spigot of the pipe.

3.08 BACKFILLING WITHIN PIPE ZONE

- A. Backfill per the detailed piping specification for the particular type of pipe and per the following.
- B. After pipe has been installed in the trench, place pipe zone material simultaneously on both sides of the pipe, keeping the level of backfill the same on each side. Carefully place the material around the pipe so that the pipe barrel is completely supported and that no voids or uncompacted areas are left beneath the pipe. Use particular care in placing material on the underside of the pipe to prevent lateral movement during subsequent backfilling.
- C. When backfill is to be placed before 7-day concrete strength tests have been conducted on concrete arches for VCP sewers or thrust blocks, the concrete shall have achieved 50 percent of the specified minimum 28-day strength. An additional test cylinder shall be made for this test.
- D. Compact material placed within 12 inches of the outer surface of the pipe by hand tamping only.
- E. Removal and replacement of any trench and backfill material which does not meet the specifications shall be the Contractor's responsibility.

3.09 COMPACTION REQUIREMENTS

- A. The Developer will engage the services of a qualified soils engineering firm to determine the relative compaction of the trench backfill. On capital projects, the District will engage the services of a qualified soils engineering firm to determine the relative compaction of the trench backfill.
- B. If the backfill fails to meet the specified relative compaction requirements, the Contractor shall rework the backfill until the requirements are met. The Contractor shall make all necessary excavations for density tests as directed by the District. Orange County Public Works, the city having jurisdiction, or Caltrans compaction requirements shall prevail in all public roads. The Developer or Contractor will be responsible for the cost of all additional compaction tests in the reworked areas.
- C. Compaction tests shall be performed at random depths and at 100-foot intervals unless otherwise directed by the District.
- D. Unless otherwise shown on the drawings or otherwise described in the specifications for the particular type of pipe installed, relative compaction in pipe trenches shall be as described below:
 - 1. Pipe zone and pipe base: 90% relative compaction
 - 2. Rock refill for over-excavation: 90% relative density
 - 3. Above pipe zone: Per requirements of city or agency having jurisdiction

3.10 RESTORATION

- A. Replace bituminous and concrete pavement, curbs, and sidewalks damaged or removed during construction in accordance with the requirements of the city or the agency having jurisdiction.

3.11 SLOPE PROTECTION

- A. Construct pipe slope anchors as shown on the Drawings wherever the profile of the ground surface above the main exceeds 20-percent, or where shown on the Drawings.
- B. Place 4-inch thick layer of cemented rubble and concrete surface slope protection wherever the profile of the ground surface above the main exceeds 20-percent, or where shown on the Drawings.
- C. A reinforced concrete encasement may be used as directed by the District. The encasement shall extend to within 1-foot of the ground surface and to within 1-foot of the toe of slope in which the pipe is constructed.

3.12 FIELD QUALITY CONTROL

- A. All trenching excavation, backfill, and compaction, shall be performed under inspection by a California licensed Geotechnical Engineer.

B. Testing for Compaction

1. Determine the density of soil in place by the use of a sand cone (ASTM D1556), drive tube (ASTM D2937), or nuclear tester (ASTM D6938).
2. Determine laboratory moisture-density relations of existing soils by ASTM D1557.
3. Determine the relative density of cohesionless soils by ASTM D4254.
4. Sample backfill materials by ASTM D75.
5. Express "relative compaction" as the ratio, expressed as a percentage, of the in place dry density to the laboratory maximum dry density.
6. Compaction shall be deemed to comply with the specifications when no test falls below the specified relative compaction.
7. The Developer will secure the services of a soils tester and pay the costs of all compaction testing. On capital projects, the District will secure the service of a soils tester and pay the cost of initial testing. The Contractor will be responsible for the cost of all retests in failed areas. Test results will be furnished by the District.
8. Compaction shall be deemed to comply with the specifications when none of the tests fall below the specified relative compaction. When tests are conducted by the District, the Contractor shall notify the District 24-hours in advance of when backfill lifts are ready for testing, and shall pay the costs of any retesting of work not conforming to the specifications.
9. Unless noted otherwise, compaction tests shall be performed at random depths at 200-foot intervals, and as directed by the District.
10. All imported or native materials shall be tested before the start of compaction operations to determine the moisture density relationship for materials with cohesive components, and the maximum density for cohesionless materials. Variations in imported or native earth materials may require a number of base curves of the moisture-density relationship.

END OF SECTION

SECTION 03300

CONCRETE

PART 1 GENERAL

1.01 SECTION INCLUDES

- A. Cast-in-place concrete

1.02 REFERENCED STANDARDS

- A. American Concrete Institute (ACI)
 - 1. ACI 117: Standard Tolerances for Concrete Construction and Materials
 - 2. ACI 211.1: Standard Practice for Selecting Proportions for Normal, Heavyweight, and Mass Concrete
 - 3. ACI 214: Recommended Practice for Evaluation of Strength Test Results of Concrete
 - 4. ACI 301: Specifications for Structural Concrete
 - 5. ACI 304R: Guide for Measuring, Mixing, Transporting, and Placing Concrete
 - 6. ACI 305R: Guide to Hot Weather Concreting
 - 7. ACI 306: Guide to Cold Weather Concreting
 - 8. ACI 308R: Guide to External Curing of Concrete
 - 9. ACI 309: Consolidation of Concrete
 - 10. ACI 315: Details and Detailing of Concrete Reinforcement
 - 11. ACI 318: Building Code Requirements for Reinforced Concrete
 - 12. ACI 347R: Guide to Formwork for Concrete
- B. American Lumber Standard Committee:
 - 1. PS 1: U.S. Product Standard for Concrete Forms, Class I
 - 2. PS 20: American Softwood Lumber Standard
- C. ASTM International (ASTM)
 - 1. ASTM A1064: Standard Specification for Carbon-Steel Wire and Welded Wire Reinforcement, Plain and Deformed, for Concrete
 - 2. ASTM C31: Practice for Making and Curing Concrete Test Specimens in the Field
 - 3. ASTM C33: Standard Specification for Concrete Aggregates
 - 4. ASTM C39: Test Method for Compressive Strength of Cylindrical Concrete Specimens
 - 5. ASTM C94: Standard Specification for Ready-Mixed Concrete
 - 6. ASTM C109: Standard Test Method for Compressive Strength of Hydraulic Cement Mortars

7. ASTM C143: Test Method for Slump of Hydraulic Cement Concrete
8. ASTM C150: Standard Specification for Portland Cement
9. ASTM C171: Standard Specification for Sheet Materials for Curing Concrete
10. ASTM C309: Specifications for Liquid Membrane Forming Compounds for Curing Concrete
11. ASTM C494: Specification for Chemical Admixtures for Concrete
12. ASTM C579: Standard Test Methods for Compressive Strength of Chemical-Resistant Mortars, Grouts, Monolithic Surfacing, and Polymer Concretes
13. ASTM A615: Standard Specification for Deformed and Plain Carbon-Steel Bars for Concrete Reinforcement
14. ASTM C827: Standard Test Method for Change in Height at Early Ages of Cylindrical Specimens of Cementitious Mixtures
15. ASTM C881: Standard Specification for Epoxy-Resin-Base Bonding Systems for Concrete
16. ASTM C920: Specification for Elastomeric Joint Sealants
17. ASTM C1077: Practice for Laboratories Testing Concrete and Concrete Aggregates for use in Construction & Criteria for Laboratory Evaluation
18. ASTM C1107: Standard Specification for Packaged Dry, Hydraulic-Cement Grout
19. ASTM D638: Test Method for Tensile Properties of Plastic
20. ASTM D747: Test Method for Apparent Bending Modulus of Plastics by Means of a Cantilever Beam

D. American Welding Society:

1. AWS D1.4: Structural Welding Code – Reinforcing Steel

E. U.S. Army Corps of Engineers (ACOE) Specifications:

1. CRD-C572: PVC Waterstop

F. Concrete Reinforcing Steel Institute (CRSI)

1. Manual of Standard Practice

1.03 SUBMITTALS

- A. General: Submit all information for all products and materials.
- B. Formwork: Calculations and drawings

C. Reinforcing:

1. Product cutsheets
2. Materials of construction
3. Shop drawings:
 - a. Details of reinforcement steel for fabrication and erection shall conform to ACI 315 and the requirements indicated.
 - b. The shop bending diagrams shall show the actual lengths of bars, to the nearest inch, measured to the intersection of the extensions (tangents for bars of circular cross section) of the outside surface.
 - c. The shop drawings shall include bar placement diagrams which clearly indicate the dimensions of each bar splice.
4. Welding procedures: The Contractor shall submit a written welding procedure for each type of weld for each size of bar which is to be spliced by welding; a mere statement that AWS procedures will be followed will not be acceptable.

D. Concrete:

1. Mix design: Sign and seal mix designs by licensed civil or structural engineer, registered in the State of California. Mix design shall include:
 - a. Indicate proposed mix design complies with requirements of ACI 301.
 - b. Indicate proposed mix design complies with requirements of ACI 318.
 - c. Provide certificate that cement used complies with ASTM C150 and these specifications.
 - d. Provide delivery tickets for ready-mix concrete or weighmasters certificate per ASTM C94, including weights of cement and each size aggregate and amount of water added at the plant and record of pours.
 - 1) Record the amount of water added on the job on the delivery ticket.
 - 2) Water added at the plant shall account for the moisture in both coarse and fine aggregate.
 - e. Provide plant qualification showing conformance with requirements of the Check List for Certification of Ready Mixed Concrete Production facilities of the National Ready Mixed Concrete Association and ASTM C94.

E. Curing: Materials and methods

1.04 DELIVERY, STORAGE, AND HANDLING

- A. Deliver reinforcing steel to the site bundled and tagged with identifying tags.

PART 2 PRODUCTS

2.01 FORMWORK

- A. Construction:
 - 1. Comply with requirements of ACI 347R
 - 2. Forms shall be accurately constructed of clean lumber and shall be of sufficient strength and rigidity to hold the concrete and to withstand the necessary pressure and tamping without deflection from the prescribed lines.
 - 3. The surface of forms against which concrete is placed shall be smooth and free from irregularities, dents, sags, or holes. The surface shall leave uniform form marks conforming to the general lines of the structure.

- B. Form Materials:
 - 1. Lumber shall be Douglas Fir or Southern Yellow Pine, construction grade or better, in conformance with U.S. Product Standard PS 20.
 - 2. Plywood for concrete formwork shall be new, waterproof, synthetic resin bonded, exterior type Douglas Fir or Southern Yellow Pine plywood manufactured especially for concrete formwork and shall conform to the requirements of PS 1 for Concrete Forms, Class I, and shall be edge sealed.

- C. Form Ties:
 - 1. Form ties with integral water stops shall be provided with a plastic code or other suitable means for forming a conical hole to insure that the form tie may be broken off back of the face of the concrete.
 - 2. The maximum diameter of removable cones for rod ties, or of other removable-tie fasteners having a circular cross-section, shall exceed 1-1/2 inches and all such fasteners shall be such as to leave holes of regular shape for reaming.

2.02 REINFORCING STEEL

- A. Reinforcing Steel: Billet steel conforming ASTM A615, Grade 60 (60,000 psi)

- B. Steel Welded Wire Reinforcement (WWR): Galvanized, plain type, ASTM A1064

- C. Fabrication:
 - 1. Conform to requirements of the Manual of Standard Practice, published by the Concrete Reinforcing Steel Institute.
 - 2. Bend reinforcing steel cold.
 - 3. Fabricate to meet tolerances of ACI 117.

- D. Tie wire: 16 gage minimum, black, soft annealed

E. Supports:

1. Bar supports: Meet the requirements of the CRSI Manual of Standard Practice, Chapter 3, including special requirements for support of epoxy coated reinforcing bars.
 - a. Wire bar supports shall be CRSI Class 1 for maximum protection with a 1/8-inch minimum thickness of plastic coating which extends at least 1/2-inch from the concrete surface. Plastic shall be gray in color.
2. Concrete blocks (dobies): Used to support and position reinforcement steel, shall have the same or higher compressive strength as specified for the concrete in which it is located. Wire ties shall be embedded in concrete block bar supports.

F. Mechanical Couplers

1. Provided where indicated and where accepted by the District
2. Tensile strength shall exceed 125-percent of the yield strength of the reinforcement bars being spliced at each splice.
3. The reinforcement steel and coupler used shall be compatible for obtaining the required strength of the connection.
4. Straight thread type couplers shall require the use of the next larger size reinforcing bar or shall be used with reinforcing bars with specially forged ends which provide upset threads which do not decrease the basic cross section of the bar.

G. Welded Splices

1. Provided where indicated and where accepted by the District.
2. Tensile strength shall exceed 125-percent of the yield strength of the reinforcement bars which are connected.
3. All materials required to conform the welded splices to the requirements of AWS D1.4 shall be provided.

2.03 PORTLAND CEMENT CONCRETE MATERIALS

A. Cement:

1. ASTM C150, Type V - Sulfate Resistant Portland type
2. Acquire cement for entire project from same source.
3. The content of tricalcium aluminate shall not exceed 6-percent and the content of alkalis shall not exceed 0.6-percent.

B. Aggregates:

1. Conform to ASTM C33
2. Acquire aggregates for entire project from same source
3. Free from any substances that will react with the cement alkalis

- 4. Coarse aggregate
 - a. Clean, hard, durable gravel, crushed rock, or combination thereof
 - b. Maximum size: 3/4-inch
- 5. Fine aggregates
 - a. Sand or a combination of natural and manufactured sand that are hard and durable
 - b. Gradation of fine aggregate shall conform to ASTM C33 with 15 to 30-percent passing the number 50 screen and 5 to 10-percent passing the number 100 screen.
- C. Water: Clean and not detrimental to concrete
- D. Admixtures:
 - 1. Do not use chemicals that will result in soluble chloride ions in excess of 0.1 percent by weight of cement.
 - 2. Water Reducing Admixture: ASTM C494 Type A
 - 3. Set Retarding Admixture: ASTM C494 Type B or D
 - 4. Set Accelerating Admixture: ASTM C494 Type C or E

2.04 CONCRETE DESIGN REQUIREMENTS

- A. Establish required average strength for concrete on the basis of trial mixtures, as specified in ACI 301.
- B. Add acceptable admixtures as recommended in ACI 211.1 and at rates recommended or required by manufacturer.
- C. At the Contractor’s option, ready mix concrete may be used meeting the requirements of ASTM C94.
- D. Concrete classes called out on the Drawings shall conform to the following:

Class	Type of work, unless indicated otherwise	28-Day Compressive Strength (in psi)	Slump (inches)	Min. Cement Content (in lbs. Per C.Y.)
A	Where shown on the Drawings	4,000	4	650 (7 sacks)
B	Thrust blocks, anchors, pipe encasement, manhole bases, and pads	3,250	5	560 (6 sacks)
C	Guard posts	2,500	5	500 (5.5 sacks)

2.05 CONCRETE ACCESSORIES

- A. Anchor bolts:
 - 1. Type 316 stainless steel
 - 2. Possess a current ICC Evaluation Service report
- B. Non-Shrink Cementitious Grout: Premixed compound consisting of non-metallic aggregate, cement, water reducing, and plasticizing agents
 - 1. Grout: Comply with ASTM C1107
 - 2. Height Change, Plastic State; when tested according to ASTM C827
 - a. Maximum: Plus 4 percent
 - b. Minimum: Plus 1 percent
 - 3. Minimum Compressive Strength at 48 Hours, ASTM C109: 2,000 pounds per square inch
 - 4. Minimum Compressive Strength at 28 Days, ASTM C109: 7,000 pounds per square inch
- C. Non-Shrink Epoxy Grout: Moisture-insensitive, two-part; consisting of epoxy resin, non-metallic aggregate, and activator
 - 1. Composition: High solids content material exhibiting positive expansion when tested in accordance with ASTM C827
 - a. Maximum Height Change: Plus 4 percent
 - b. Minimum Height Change: Plus 1 percent
 - 2. Minimum Compressive Strength at 7 days, ASTM C579: 12,000 pounds per square inch
- D. Joint Sealant:
 - 1. Elastomeric Sealant complying with requirements of ASTM C920
 - 2. Plastic Foam Joint-Fillers: Preformed, compressible, resilient, non-waxing, non-extruding strips of plastic foam of either flexible open cell polyurethane foam or non-gassing closed-cell polyethylene foam, subject to sealant manufacturer's approval
 - 3. Bond-breaker tape: designed to prevent bond between sealant and joint filler
- E. Concrete bonding agent:
 - 1. Epoxy Bonding System
 - 2. Comply with ASTM C881
- F. Dampproofing agent: Asphalt emulsion
- G. Waterstops:
 - 1. Extruded PVC, complying with ACOE CRD-C 572.
 - 2. Ribbed with centerbulb with minimum 3/8-inch thickness
 - 3. Prefabricated joint fittings shall be used at all intersections of the ribbed-type waterstops.

4. Tensile strength: 1,400 psi per ASTM D638, Type IV
5. Stiffness in Flexure: 400 psi per ASTM D747

PART 3 EXECUTION

3.01 FORMWORK INSTALLATION

- A. Design and install formwork in compliance with requirements of ACI 347R.
- B. The Contractor shall notify the District a minimum of one working day before the placement of concrete to enable the District to check the form lines, grades, and other required items for acceptance before placement of concrete.
- C. Unless otherwise indicated on the plans, all exposed sharp edges shall be chamfered with at least 3/4 - by 3/4 inch triangular fillets.
- D. Before placing concrete, the form surface shall be clean and coated with form oil of high penetrating qualities.
- E. All embedded bolts, dowels, anchors, and other embedded items shall be held correctly in place in the forms before concrete is placed.
- F. Ties:
 1. Holes left by the removal of form tie cones shall be reamed with suitable toothed reamers so as to leave the surface of the holes clean and rough before being filled with mortar. Ties shall not be removed in such manner as to leave a hole extending through the interior of the concrete members.
 2. After the taper tie is removed, the hole shall be thoroughly cleaned and roughened for bond. A precast neoprene or polyurethane tapered plug shall be located at the wall centerline. The hole shall be completely filled with non-shrink grout for water bearing and below-grade walls. The hole shall be completely filled with non-shrink or regular cement grout for above-grade walls which are dry on both sides.
- G. Forms shall be maintained at all times in good condition, particularly as to size, shape, strength, rigidity, tightness, and smoothness of surface.
- H. False Work: The Contractor shall be responsible for the design, engineering, construction, maintenance and safety of all false work, including staging, walkways, forms, ladders, and similar appurtenances, which shall equal or exceed the applicable requirements of the provisions of the OSHA Safety and Health Standards for Construction, and the requirements of the California Division of Industrial Safety.

3.02 REINFORCEMENT

- A. General:
 1. Place reinforcing steel in accordance with CRSI Manual of Standard Practice.
 2. All reinforcing steel shall be of the required sizes and shapes and placed where shown on the drawings or prescribed by the District.

3. Do not straighten or rebend reinforcing steel in a manner that will injure the material. Do not use bars with bends not shown on the drawings.
4. All bars shall be free from rust, scale, oil, or any other coating which would reduce or destroy the bond between concrete and steel.
5. All reinforcing steel and wire mesh shall be completely encased in concrete.
6. Place additional reinforcement around the pipe or opening as indicated in the drawings.
7. Position reinforcement steel in accordance with the drawings and secure by using annealed wire ties or clips at intersections and support by concrete or metal supports, spacers, or metal hangers. Do not place metal clips or supports in contact with the forms. Bend tie wires away from the forms in order to provide the specified concrete coverage. Bars additional to those shown on the drawings, which may be found necessary or desirable by the Contractor for the purpose of securing reinforcement in position, shall be provided and paid for by the Contractor.
8. Secure reinforcing dowels in place prior to placing concrete. Do not press dowels into the concrete after the concrete has been placed.
9. Place reinforcement a minimum of 2 inches clear of any metal pipe or fittings.
10. Minimum lap for all reinforcement shall be 20 bar diameters.

B. Wire Mesh

1. Wire mesh reinforcement is to be rolled flat before being placed in the form. Support and tie wire mesh to prevent movement during concrete placement.
2. Extend welded wire fabric to within 2 inches of the edges of the slab. Lap splices at least 1-1/2 courses of the fabric and a minimum of 6 inches. Tie laps and splices securely at ends and at least every 24 inches with 16 gage black annealed steel wire. Pull the fabric into position as the concrete is placed by means of hooks, and work concrete under the steel to ensure that it is at the proper distance above the bottom of the slab.

C. Ties: The reinforcement shall be so secured in position that it will not be displaced during the placement of concrete.

D. Limitations on the use of the bar support materials shall be as follows:

1. Concrete Dobies: Permitted at all locations except where architectural finish is required.
2. Wire Bar Supports: Permitted only at slabs over dry areas, interior dry wall surfaces and exterior wall surfaces.
3. Plastic Bar Supports: Permitted at all locations except on grade.

E. Splices

1. General: Splicing shall be in accordance with ACI 318, unless otherwise noted on Drawings.
2. Vertical Bars: Except as specifically detailed or otherwise indicated, splicing of vertical bars in concrete is not permitted, except at the indicated or approved horizontal construction joints or as otherwise specifically detailed.
3. Horizontal Bars: Except as specifically detailed or otherwise indicated, splicing of horizontal bars in concrete is not permitted.

4. Mechanical Couplers: Unless otherwise indicated or accepted by the District, use of mechanical couplers is not permitted.
5. Welding: Except as specifically detailed or otherwise indicated, welding of reinforcing bars is not permitted.

3.03 DRILLED EPOXY DOWELS

- A. The hole diameter shall be as recommended by the epoxy manufacturer but shall be no larger than 0.25 inch greater than the diameter of the outer surface of the reinforcing bar deformations.
- B. The depth of the hole shall be as recommended by the epoxy manufacturer to fully develop the bar but shall not be less than 12 bar diameters, unless noted otherwise.
- C. The location of holes to be drilled shall be adjusted to avoid drilling through or nicking any existing reinforcing bars.
- D. Install epoxy per manufacturer's recommendations.

3.04 MIXING AND PLACING CONCRETE

- A. Concrete, either commercial of on-site ready mix or batch mixed, shall be placed in the forms before taking its initial set.
- B. No concrete shall be placed in water except with permission of the District.
- C. As the concrete is placed in the forms, or in excavations to be filled with concrete, it shall be thoroughly settled and compacted throughout the entire layer by internal vibration and tamping bars.
- D. All concrete surfaces upon which or against which the concrete is to be placed, and to which new concrete is to adhere, shall be roughened, thoroughly cleaned, wet, and grouted before the concrete is deposited.
- E. Maintain records of concrete placement. Record date, location, quantity, air temperature, and test samples taken.
- F. Ensure reinforcement, inserts, and formed construction joint devices will not be disturbed during concrete placement.
- G. Place concrete continuously without construction (cold) joints wherever possible.
 1. Where construction joints are necessary, before next placement prepare joint surface by removing laitance and exposing the sand and sound surface mortar, by sandblasting or high-pressure water jetting.
 2. Provide construction joints at 25-foot maximum spacing, unless noted otherwise.
- H. Cold Weather Placement:
 1. Placement of concrete shall conform to ACI 306 – Standard Specification for Cold Weather Concreting and the following.

2. Remove all snow, ice and frost from the surfaces, including reinforcement, against which concrete is to be placed. Before beginning concrete placement, thaw the subgrade to a minimum depth of 6 inches. All reinforcement and embedded items shall be warmed to above 32 degrees F before concrete placement.
3. Concrete ingredients shall not be heated to a temperature higher than that necessary to keep the temperature of the mixed concrete, as placed, from falling below the specified minimum temperature.
4. Maintain the concrete temperature above 50 degrees F for at least 3 days after placement.

I. Hot Weather Placement:

1. Placement of concrete shall conform to ACI 305R – Hot Weather Concreting, and the following.
2. When the temperature of the concrete is 85 degrees F or above, the time between the introduction of the cement to the aggregates and discharged shall not exceed 45 minutes.
3. If concrete is placed when the weather is such that the temperature of the concrete would exceed 90 degrees F, the Contractor shall employ effective means, such as pre-cooling aggregates and mixing water using ice or placing at night, as necessary to maintain the temperature of the concrete, as it is placed, below 90 degrees F. The Contractor shall be entitled to no additional compensation on account of foregoing requirements.
4. Only set retarding admixture shall be used in concrete when air temperature is expected to be consistently over 80 degrees F.
5. The maximum temperature of concrete shall not exceed 90 degrees F immediately before placement.
6. From the initial placement to the curing state, concrete shall be protected from the adverse effect of high temperature, low humidity and wind.

3.05 PUMPING OF CONCRETE

- A. General: If the pumped concrete does not produce satisfactory end results, discontinue the pumping operation and proceed with the placing of concrete using conventional methods.
- B. Pumping Equipment: The pumping equipment must have two cylinders and be designed to operate with one cylinder only in case the other is not functioning. In lieu of this requirement, the Contractor may have a standby pump on the site during pumping.
- C. The minimum diameter of the hose (conduits) shall be in accordance with ACI 304R.
- D. Pumping equipment and hoses (conduits) that are not functioning properly shall be replaced.
- E. Aluminum conduits for conveying the concrete shall not be permitted.
- F. Field Control: Concrete samples for slump, air content and test cylinders will be taken at the placement (discharge) end of the line.

3.06 TAMPING AND VIBRATING

- A. As concrete is placed in the forms or in excavations, it shall be thoroughly settled and compacted throughout the entire depth of the layer which is being consolidated, into a dense homogeneous mass, filling all corners and bringing only a slight excess of water to the exposed surface of concrete during placement. Vibrators shall be Group 3 (per ACI 309) high speed power vibrators (8,000 to 12,000 rpm) of an immersion type in sufficient number and with (at least one) standby unit(s) as required. Group 2 vibrators may be used only at specific locations when accepted by the District.
- B. Care shall be used in placing concrete around waterstops. The concrete shall be carefully worked by rodding and vibrating to make sure that all air and rock pockets have been eliminated. Where flat-strip type waterstops are placed horizontally, the concrete shall be worked under the waterstops by hand, making sure that all air and rock pockets have been eliminated. Concrete surrounding the waterstops shall be given additional vibration, over and above that used for adjacent concrete placement to assure complete embedment of the waterstops in the concrete.
- C. Concrete in walls shall be internally vibrated and at the same time rammed, stirred, or worked with suitable appliances, tamping bars, shovels, or forked tools until it completely fills the forms or excavations and closes snugly against all surfaces. Subsequent layers of concrete shall not be placed until the layers previously placed have been worked thoroughly as required, to accomplish the results herein specified within 15 minutes after concrete of the prescribed consistency is placed in the forms. The vibrating head shall be kept from contact with the surfaces of the forms. Care shall be taken not to vibrate concrete excessively or to work it in any manner that causes segregation of its constituents.

3.07 CONCRETE FINISHING

- A. Surfaces shall be free from fins, bulges, ridges, offsets, honeycombing or roughness of any kind, and shall present a finished, smooth, continuous hard surface.
- B. Surface holes larger than 1/2 inch in diameter or deeper than 1/4 inch are defined as surface defects in basins and exposed walls.
- C. Immediately upon the removal of forms, all voids shall be neatly filled with cement mortar.
- D. The surfaces of concrete to be permanently exposed to view must be smooth, free from projections, and thoroughly filled with mortar.
- E. Exposed surfaces of concrete not finished against forms, such as horizontal or sloping surfaces, shall be screened to a uniform surface and worked with suitable tools to a smooth mortar finish.

3.08 PROTECTION AND CURING OF CONCRETE

- A. Comply with requirements of ACI 308R. Immediately after placement, protect concrete from premature drying, excessively hot or cold temperatures, and mechanical injury.
- B. Exposed surfaces of new concrete shall be protected from the direct rays of the sun and from frost by being kept damp for at least two weeks after the concrete has been placed, or by using accelerant / retardant compound process or approved equal accepted by the District.
- C. Maintain concrete with minimal moisture loss at relatively constant temperature for period necessary for hydration of cement and hardening of concrete.
- D. Formed Surfaces: Cure by moist curing with forms in place for full curing period.
- E. Surfaces Not in Contact with Forms:
 - 1. Initial Curing: Start as soon as free water has disappeared and before surface is dry. Keep continuously moist for not less than three days by water ponding, water-saturated sand, water-fog spray, or saturated burlap.
 - 2. Final Curing: Begin after initial curing but before surface is dry.
 - a. Moisture-Retaining Sheet: Lap strips not less than 3 inches and seal with waterproof tape or adhesive; secure at edges.
 - b. Curing Compound: Apply in two coats at right angles, using application rate recommended by manufacturer.

3.09 FORMWORK REMOVAL

- A. Carefully remove formwork to avoid injury to the concrete.
- B. No heavy loading on green concrete will be permitted.
- C. Do not backfill against walls until the top slab is in place and all concrete has obtained compressive strength equal to the specified 28-day compressive strength.

- D. Formwork removal periods:
 - 1. General: Remove once 28-day compressive strength is achieved, except as noted otherwise.
 - 2. Curbs: Sufficient time to hold shape
 - 3. Non-load bearing walls: 16 hours
- E. Forms may be reused only if in good condition and only if acceptable to the District.

3.10 FIELD QUALITY CONTROL

- A. Field Testing: Perform field testing on all Class A concrete as follows:
 - 1. Tests on component materials and for compressive strength and shrinkage of concrete will be performed as specified herein. Test for determining slump will be in accordance with requirements of ASTM C143.
 - 2. The cost of all laboratory tests requested by the District on cement, aggregates and concrete will be borne by the District. However, the Contractor will be charged for the cost of any additional tests and investigation on work performed which does not meet the specifications. The laboratory must meet or exceed the requirements of ASTM C1077.
 - 3. The Contractor shall provide assistance to the District in obtaining samples and disposal and clean up of excess material.
 - 4. Field Compression Tests:
 - a. Compression test specimens will be taken during construction from the first placement of each class of concrete specified herein and at intervals thereafter as selected by the District to ensure continued compliance with these specifications. Each set of test specimens will be a minimum of five cylinders.
 - b. Compression test specimens for concrete shall be made in accordance with section 9.2 of ASTM C31. Specimens shall be 6-inch diameter by 12-inch high cylinders.
 - c. Compression tests shall be performed in accordance with ASTM C39. One test cylinder will be tested at 7 days and two at 28 days. The remaining cylinders will be held to verify test results, if needed.
 - 5. Evaluation and Acceptance of Concrete:
 - a. Evaluation and acceptance of the compressive strength of concrete shall be according to the requirements of ACI 318, Chapter 5 "Concrete Quality" and as specified herein.
 - b. A statistical analysis of compression test results will be performed according to the requirements of ACI 214. The standard deviation of the test results shall not exceed 640 psi when ordered at equivalent water content as estimated by slump.
 - c. If any concrete fails to meet these requirements, immediate corrective action shall be taken to increase the compressive strength for all subsequent batches of the type of concrete affected.

MOULTON NIGUEL WATER DISTRICT

- d. When the standard deviation of the test results exceeds 640 psi, the average strength for which the mix is designed shall be increased by an amount necessary to satisfy the statistical requirement that the probability of any test being more than 500 psi below or the average of any three consecutive tests being below the specified compressive strength is 1 in 100. The required average strength shall be calculated by Criterion No. 3 of ACI 214 using the actual standard of deviation.
- e. All concrete which fails to meet the ACI requirements and these specifications is subject to removal and replacement at no additional cost to the District.

B. Tolerances:

- 1. Formwork: Comply with ACI 347
- 2. Concrete:
 - a. Set and maintain concrete forms and perform finishing operations so as to ensure that the completed work is within the tolerances specified herein.
 - b. Surface defects and irregularities are defined as finishes and are to be distinguished from tolerances.
 - c. Tolerance is the specified permissible variation from lines, grades or dimensions shown.
 - d. Where tolerances are not slated in the specifications, permissible deviations will be in accordance with ACI 117.
 - e. The following construction tolerances are hereby established and apply to finished walls and slab unless otherwise shown:

Item	Tolerance
Variation of the constructed linear outline from the established position in plan	In 10 feet: 1/4-inch In 20 feet or more: 1/2-inch
Variation from the level or from the grades shown	In 10 feet: 1/4-inch In 20 feet or more: 1/2-inch
Variation from the plumb	In 10 feet: 1/4-inch In 20 feet or more: 1/2-inch
Variation in the thickness of slabs and walls	Minus 1/4-inch; Plus 1/2-inch
Variation in the locations and sizes of slabs and wall openings	Plus or minus 1/4-inch

END OF SECTION

SECTION 03461

PRECAST REINFORCED CONCRETE MANHOLES

PART 1 GENERAL

1.01 SECTION INCLUDES

- A. Precast reinforced concrete manholes
- B. Manhole bases
- C. Manhole frames and covers

1.02 RELATED REQUIREMENTS

- A. Section 02200, Earthwork
- B. Section 02223, Trenching, Backfilling, and Compacting
- C. Section 03300, Concrete
- D. Section 15043, Testing of Non-Pressure Sewer Pipelines and Manholes

1.03 REFERENCED STANDARDS

- A. American Society of Testing and Materials (ASTM)
 - 1. ASTM A48: Standard Specification for Gray Iron Castings
 - 2. ASTM A536: Standard Specification for Ductile Iron Castings
 - 3. ASTM C31: Standard Practice for Making and Curing Concrete Test Specimens in the Field
 - 4. ASTM C39: Standard Test Method for Compressive Strength of Cylindrical Concrete Specimens
 - 5. ASTM C138: Standard Test Method for Density (Unit Weight), Yield, and Air Content (Gravimetric) of Concrete
 - 6. ASTM C143: Standard Test Method for Slump of Hydraulic-Cement Concrete
 - 7. ASTM C150: Standard Specification for Portland Cement
 - 8. ASTM C173: Standard Test Method for Air Content of Freshly Mixed Concrete by the Volumetric Method
 - 9. ASTM C192: Standard Practice for Making and Curing Concrete Test Specimens in the Laboratory
 - 10. ASTM C231: Standard Test Method for Air Content of Freshly Mixed Concrete by the Pressure Method

11. ASTM C478: Standard Specification for Circular Precast Reinforced Concrete Manhole Sections
 12. ASTM C990: Standard Specification for Joints for Concrete Pipe, Manholes, and Precast Box Sections Using Preformed Flexible Joint Sealants
- B. American Association of State Highway and Transportation Officials (AASHTO)
1. AASHTO M306: Standard Specification for Drainage, Sewer, Utility, and Related Castings
- C. State of California Construction Safety Orders
1. Article 4, Section 1532 "Confined Spaces"

1.04 SUBMITTALS

- A. Design calculations and detailed drawings of component sections signed by a registered California Professional Engineer. Show dimensions and materials of construction by ASTM reference and grade.
- B. Shop drawings of grating, grating frame embeds, covers, and all appurtenances
- C. Shop drawings indicating the installation procedures and dimensions, and the location of all joints or welded strips
- D. Results of testing required per paragraph of this specification entitled "Quality Assurance"
- E. Qualifications of engineer designing the precast concrete structure
- F. Recommendations for inlet and outlet seals, and watertight caulking
- G. Show manhole cover lettering and pattern.

1.05 QUALITY ASSURANCE

- A. Precast concrete producer shall demonstrate adherence to the standards set forth in the National Precast Concrete Association Quality Control Manual.
- B. The precast concrete producer shall have been in the business of producing precast concrete products similar to those specified for a minimum of 5 years. The precast concrete producer shall maintain a permanent quality control department, or retain an independent testing agency on a continuing basis. The agency shall issue a report, certified by a licensed engineer, detailing the ability of the precast concrete producer to produce quality products consistent with industry standards.
- C. The precast concrete producer shall show that the following tests are performed in accordance with the ASTM standards indicated. Tests shall be performed for each 150 cu. yd. of concrete placed, but not less frequently than once per week.
1. Slump: C143
 2. Compressive Strength: C31, C192, C39

- 3. Air Content (when air-entrained concrete is being used): C231 or C173
 - 4. Unit Weight: C138
- D. The District may place an inspector in the plant when the products covered by this specification are being manufactured.

PART 2 PRODUCTS

2.01 PRECAST CONCRETE MANHOLES

- A. General: Precast reinforced concrete manholes shall comply with ASTM C478, with a minimum wall thickness of 6-inches.
- B. Design Load: Manhole components shall be designed for H-20 highway loads and site soil conditions.
- C. Cement: Type V per ASTM C 150
- D. Manhole Section Configuration: Manholes shall be fabricated only from eccentric taper sections and standard cylinder units of the proper internal diameter.
- E. Manhole Section Dimensions:
 - 1. Unless noted otherwise, minimum internal diameter manhole sections shall be as follows:

Depth, feet	Manhole Diameter, in
<12	48
≥12	60

- 2. Depth of cover shall be measured from proposed finish surface elevation to the lowest pipe invert.
- F. Steps: Manhole sections shall be cast without steps.

2.02 CAST IRON MANHOLE FRAMES AND COVERS

- A. Location: paved areas
- B. General Requirements:
 - 1. Manhole frames and covers shall be made of ductile iron conforming to ASTM A536, Class 400, or cast iron conforming to ASTM A48, Class 30.
 - 2. Casting shall be smooth, clean, and free from blisters, blowholes, and shrinkage.
 - 3. Frames and covers shall be of the traffic type, designed for H-20 loading.
 - 4. Provide locking bolt-down covers where shown on drawings
 - a. Stainless steel hardware

- b. Non-standard bolt head pattern; provide tool
- C. Fit and Matchmarking: Each manhole cover shall be ground or otherwise finished so that it will fit in its frame without rocking. Frames and covers shall be matchmarked in sets before shipping to the site.
- D. Cover Inscription: Per Standard Drawing
- E. Inspection and Coating: Before leaving the foundry, castings shall be cleaned and subjected to a hammer inspection. Castings shall then be dipped twice in a preparation of asphalt or coal tar and oil applied at a temperature of not less than 290°F, not more than 310°F, and in such a manner as to form a firm and tenacious coating.

2.03 COMPOSITE MANHOLE FRAMES AND COVERS

- A. Location: un-paved areas
- B. Description:
 - 1. Manhole frames and covers with quarter-turn locking mechanism
 - 2. Suitable for one-person operation
 - 3. Max weight of 50 pounds
- C. Performance Criteria:
 - 1. Resistant to corrosion, wear, and UV
 - 2. Load Bearing: H-20 loading
- D. Materials: Fiber reinforced polymer or approved equal

2.04 MANHOLE BASES

- A. Cast in place concrete
 - 1. Class B concrete, Type V cement per Section 03300
 - 2. 3/4-inch-maximum size aggregate
 - 3. Slump of not greater than 2-inches

2.05 EPOXY GROUT

- A. Epoxy grout shall be used in repairing manhole and manhole base surfaces. Epoxy grout shall be made with epoxy and sand. The sand shall be clean, bagged, graded, and kiln dried silica sand. The prepared grout shall wet the contact surface and provide proper adhesion, or a coat of epoxy shall be applied prior to placing the epoxy grout.

2.06 JOINT SEALING COMPOUND

- A. The joint sealing compound shall be a permanently flexible plastic material complying to ASTM C990 and AASHTO M198-751 (Type B).

PART 3 EXECUTION

3.01 WORK WITHIN EXISTING MANHOLES

- A. Any proposed work inside an existing manhole that is part of a sewerage system in service, shall not be undertaken until all the tests and safety provisions of Article 4, Section 1532 "Confined Spaces" State of California Construction Safety Orders have been made.

3.02 EXCAVATION

- A. Excavation for the precast concrete manhole shall be in accordance with Section 02223.

3.03 MANHOLE BASE

- A. General: Manhole bases shall be poured in place against undisturbed soil with concrete. The manhole base shall be poured as one monolithic pour. Limitations for site-mixed and ready-mixed concrete set forth in Section 03300 shall be observed. A 12-inch thick base of 3/4-inch crushed rock shall be placed prior to the placement of concrete for all installations.
- B. Manhole Stub Placement: The manhole stubs and sewer main shall be set before the concrete is placed and shall be rechecked for alignment and grade before the concrete has set. The various sized inlets and outlets to the manhole shall be located as indicated on the plans and as detailed in the detail drawings.
- C. Matching Pipe Crown Elevations: Invert elevations of connecting sewers may vary depending upon sizes. The crown elevation of all pipes shall be the same as the crown elevation of the largest pipe, unless otherwise indicated on the plans.
- D. Channel Configuration: The invert of the manhole base shall be formed so as to provide smooth channels conforming in size and shape to the lower portions of the inlet and outlet pipes. The channel shall vary uniformly in size and shape from inlet to outlet, and a shelf shall be constructed higher than the pipe as indicated on the drawings. The manhole base shall extend 12-inches below the bottom of the lowest pipe.
- E. Transitions: All transitions shall be smooth and of the proper radius to give an uninterrupted transition of flow.
- F. Finishing: The concrete base shall be shaped with a wood float and shall receive a hard steel trowel finish before the concrete sets.
- G. Placement of Additional Mortar: In the event additional mortar is required after initial set has taken place, the surface to receive the mortar shall be primed, and the mortar mixed with a concrete adhesive in the amounts and proportions recommended by the manufacturer and as directed by the District in order to secure as chip-proof a result as possible.
- H. Curing Time Before Further Construction: Unless accepted otherwise by the District in advance, the bases shall set a minimum of 24 hours before the manhole construction is continued.

3.04 INSTALLING MANHOLES

- A. Joints: Precast concrete manhole units shall be set in a bed of grout to make a watertight joint at least 1/2 inch thick with the concrete base or with the preceding unit. Manhole sections shall be set plumb. Inside joints shall be pointed and the excess grout removed. Preformed, cold-applied, ready-to-use, plastic joint sealing compound may be substituted for grout between units and must be used when groundwater is encountered.

- B. Finish Elevation of Manhole Covers: Precast sections shall be assembled so that the cover conforms to the elevation determined by the manhole location as follows, but limited to a maximum of 18-inches from the top of the manhole cone to the top of the ring and cover, unless otherwise instructed by the District.
 - 1. In Paved Area: Top of cover shall be flush with the paving surface.
 - 2. In Shoulder Areas: Top of cover shall be flush with existing surface where it is in traveled way or shoulder and 0.1 foot above existing surface where outside limits of traveled way but not in the existing roadside ditch.
 - 3. In Roadside Ditch or Unpaved Open Areas: Top of cover shall be a minimum of 6-inches above the ground surface and surrounded with a concrete collar. In special instances, as designated by the District or as shown on the plans, the top of the cover shall be flush with the surrounding ground surface and within a square concrete pad 2 feet larger than the manhole frame. Guard posts or paddle boards may be required adjacent to manholes in open areas.
 - 4. Manhole Frame and Cover: The manhole frame shall be bolted to grade ring and secured with grout and cement mortar fillet. After the frames are securely set, the frames and the covers shall be cleaned and scraped free of foreign materials, and shall be ground or otherwise finished as needed so the cover fits in its frame without rocking.
 - 5. Watertightness: It is the intent of these specifications that manholes and appurtenances be watertight and free from infiltration. All manholes are to be banded both inside and outside with cement-mortar grout. Where called for in the plans or supplemental specifications, manholes that are to be given a protective lining or coating shall be free of any seeping or surface moisture.
 - 6. Stubs: Sewer pipe shall be furnished and installed in manholes at the locations shown and in conformance with the detail drawings and plans. All stubs shall be plugged with stoppers as shown on the plans for various sizes of pipe.
 - 7. Sealing Before Completion: In order to prevent accidental use of the new sewer before completion and acceptance, the inlet to existing tie-in manholes shall be sealed with a mechanical plug. Installation of these plugs shall be accepted by the District. Plugs shall be removed at the time of final inspection or as directed by the District.
 - 8. Bulkheads: Brick and mortar bulkheads shall be installed at the downstream end of all unused stub channels over 5 feet long to prevent the creation of a septic condition resulting from ponding of sewage and debris in the unused channels, and until such time as the manhole stub is connected and normal sewage flow can occur. A plug shall be required for all downstream stubs.
 - 9. New Mainline Connections to Existing Manholes: New mainline connections to existing manholes wherein stubs have not been provided shall be made by core drilling through the base, as directed by the District.

10. Backfill: Backfill in accordance with Section 02200.
11. Concrete Collar: Class B concrete collar shall be cast around manhole frames that are flush with the surface. The collar shall be placed after final grading or paving together with final cleanup.
12. Pavement Replacement: Replacement of bituminous or concrete pavement shall be in accordance with the requirements of the governmental agency having jurisdiction.

3.05 TESTING

- A. The adequacy of manholes and appurtenances as to watertightness shall be determined by the District and shall be tested in accordance with Section 15043.

3.06 MANHOLE AND MANHOLE BASE REPAIRS

- A. Manhole sections and bases that exhibit defects in the concrete surface may be rejected. Defective concrete surfaces of manhole sections and bases not rejected shall be repaired by chipping away unsound or imperfect concrete. Edges shall be left sharp and square with the surface. Loose material and dust remaining after chipping shall be removed by means of an air jet. Epoxy grout shall be applied to the surface to be repaired in accordance with the manufacturer's instructions. The grout shall wet the contact surface and provide proper adhesion, or a coat of epoxy shall be applied prior to placing the epoxy grout.

END OF SECTION

SECTION 03462

PRECAST CONCRETE VAULTS

PART 1 GENERAL

1.01 SECTION INCLUDES

- A. Precast concrete vaults
 - 1. Precast concrete meter boxes for meters 2-inch and smaller shall be purchased from the District and installed by the Contractor unless noted otherwise.
 - 2. The Contractor shall furnish and install precast concrete vaults for meter installations 3-inch and larger and other applications.

1.02 RELATED REQUIREMENTS

- A. Section 02200, Earthwork

1.03 REFERENCED STANDARDS

- A. ASTM C31: Standard Practice for Making and Curing Concrete Test Specimens in the Field
- B. ASTM C39: Standard Test Method for Compressive Strength of Cylindrical Concrete Specimens
- C. ASTM C138: Standard Test Method for Density (Unit Weight), Yield, and Air Content (Gravimetric) of Concrete
- D. ASTM C143: Standard Test Method for Slump of Hydraulic-Cement Concrete
- E. ASTM C150: Standard Specification for Portland Cement
- F. ASTM C173: Standard Test Method for Air Content of Freshly Mixed Concrete by the Volumetric Method
- G. ASTM C192: Standard Practice for Making and Curing Concrete Test Specimens in the Laboratory
- H. ASTM C231: Standard Test Method for Air Content of Freshly Mixed Concrete by the Pressure Method
- I. ASTM C857: Standard Practice for Minimum Structural Design Loading for Underground Precast Concrete Utility Structures
- J. ASTM C858: Standard Specification for Underground Precast Concrete Utility Structures
- K. ASTM C891: Standard Practice for Installation of Underground Precast Concrete Utility Structures

- L. ASTM C900: Standard Test Method for Pullout Strength of Hardened Concrete
- M. ASTM C990: Standard Specification for Joints for Concrete Pipe, Manholes, and Precast Box Sections Using Preformed Flexible Joint Sealants
- N. AASHTO M-198: Standard Specification for Joints for Concrete Pipe, Manholes, and Precast Box Sections Using Preformed Flexible Joint Sealants
- O. Federal Specification SS-A-701

1.04 SUBMITTALS

- A. Design calculations and detailed drawings of component sections signed by a registered California Professional Engineer. Show dimensions and materials of construction by ASTM reference and grade.
- B. Shop drawings of grating, grating frame embeds, covers, and all appurtenances
- C. Shop drawings indicating the installation procedures and dimensions and the location of all joints or welded strips
- D. Results of testing required per paragraph of this specification entitled "Quality Assurance"
- E. Qualifications of engineer designing the precast concrete structure
- F. Recommendations for inlet and outlet seals and watertight caulking

1.05 QUALITY ASSURANCE

- A. Precast concrete producer shall demonstrate adherence to the standards set forth in the National Precast Concrete Association Quality Control Manual.
- B. The precast concrete producer shall have been in the business of producing precast concrete products similar to those specified, for a minimum of 5 years. The precast concrete producer shall maintain a permanent quality control department or retain an independent testing agency on a continuing basis. The agency shall issue a report, certified by a licensed engineer, detailing the ability of the precast concrete producer to produce quality products consistent with industry standards.
- C. The precast concrete producer shall show that the following tests are performed in accordance with the ASTM standards indicated. Tests shall be performed for each 150 cu. yd. of concrete placed, but not less frequently than once per week.
 - 1. Slump: C143
 - 2. Compressive Strength: C31, C192, C39
 - 3. Air Content (when air-entrained concrete is being used): C231 or C173
 - 4. Unit Weight: C138
- D. The District may place an inspector in the plant when the products covered by this specification are being manufactured.

PART 2 PRODUCTS

2.01 PRECAST CONCRETE VAULT

- A. General: Comply with requirements of ASTM C858
- B. Cement: Type II or V per ASTM C150
- C. Design loads: Comply with requirements of ASTM C857 using HS-20 live load.
- D. Sizes shall be as specified on the standard drawings for the various sizes and types of services.

2.02 METER BOX COVERS

- A. All meter box covers shall be touch-read type.
- B. Polymer meter box covers shall be installed only in non-traffic locations.
- C. Steel traffic-rated meter box covers shall be installed in traffic locations.

2.03 VAULT FRAMES AND COVERS

- A. Vault frames and covers shall be fabricated aluminum.
- B. Covers shall be fabricated with supports to resist deflection.
- C. All covers shall be hinged. Covers shall have spring assists.
- D. All covers shall be equipped with a hold-open mechanism.
- E. All covers shall be equipped with a flush locking devices.
- F. All vaults that may be subject to equipment or vehicle loading shall have HS-20 live load rated covers. Vaults in non-traffic areas shall have covers rated for 300 pounds per square foot unless specified otherwise by the District.
- G. Size per drawings.
- H. Build up so that the cover is flush with the surrounding surface unless otherwise specified on the drawings or by the District in the field.

2.04 JOINT SEALING COMPOUND

- A. The joint sealing compound shall be a permanently flexible plastic material complying to ASTM C990 and AASHTO M198-751 (Type B).

2.05 WATERPROOFING

- A. Apply waterproofing formulated to comply with Federal Specification SS-A-701.

PART 3 EXECUTION

3.01 EARTHWORK

- A. Excavation and backfill for precast concrete vaults shall be in accordance with Section 02200 and the requirements herein.
- B. The Contractor shall prepare an excavation large enough to accommodate the structure and permit grouting of openings and backfilling operations.
- C. The bottom of the structure shall be placed on 12 inches of compacted, crushed rock sub-base, graded level and to the proper elevation as shown on the plans.

3.02 INSTALLATION

- A. Install per requirements of ASTM C891.
- B. Openings or "knockouts" in precast concrete vaults shall be located as shown on the drawings and shall be sized sufficiently to permit passage of the largest dimension of pipe and/or coupling flange. Upon completion of installation, all voids or openings in the vault walls around pipes shall be filled with 3,000-psi concrete or mortar, using an approved epoxy for bonding concrete surfaces.
- C. After the structure and all appurtenances are in place and accepted, backfill shall be placed to the original ground line or to the limits designated on the plans.
- D. All joints between precast concrete vault sections shall be made watertight using preformed mastic material. The sealing compound shall be installed according to the manufacturer's recommendations to provide a watertight joint which remains impermeable throughout the design life of the structure. All joints shall be filled with dry-pack non-shrink grout.
- E. Frames and covers shall be built up so that the cover is flush with the surrounding surface unless otherwise specified on the drawings or by the District in the field. The Contractor is responsible for placing the cover at the proper elevation where paving is to be installed and shall make all necessary adjustments so that the cover meets these requirements.
- F. Waterproofing shall be applied to the exterior walls of all buried vaults in accordance with the manufacturer's instructions. Protection shall be placed over the waterproofing to prevent damage.

3.03 METER BOXES

- A. Boxes shall be set true to line and to the grade of the top of the curb, sidewalk, or surrounding graded area.
- B. Meter boxes are not to be set until fine grading for landscape grading has been completed by the Developer.
- C. Retaining walls may be required around meter boxes installed on slopes as determined by the District.

END OF SECTION

SECTION 03463

GREASE INTERCEPTORS

PART 1 GENERAL

1.01 SECTION INCLUDES

- A. Precast concrete grease interceptors

1.02 RELATED REQUIREMENTS

- A. Section 02200, Earthwork
- B. Section 03461, Precast Reinforced Concrete Manholes
- C. Section 03462, Precast Concrete Vaults

1.03 REFERENCED STANDARDS

- A. ASTM C31: Standard Practice for Making and Curing Concrete Test Specimens in the Field
- B. ASTM C39: Standard Test Method for Compressive Strength of Cylindrical Concrete Specimens
- C. ASTM C138: Standard Test Method for Density (Unit Weight), Yield, and Air Content (Gravimetric) of Concrete
- D. ASTM C143: Standard Test Method for Slump of Hydraulic-Cement Concrete
- E. ASTM C150: Standard Specification for Portland Cement
- F. ASTM C173: Standard Test Method for Air Content of Freshly Mixed Concrete by the Volumetric Method
- G. ASTM C192: Standard Practice for Making and Curing Concrete Test Specimens in the Laboratory
- H. ASTM C231: Standard Test Method for Air Content of Freshly Mixed Concrete by the Pressure Method
- I. ASTM C890: Standard Practice for Minimum Structural Design Loading for Monolithic or Sectional Precast Concrete Water and Wastewater Structures
- J. ASTM C1613: Standard Specification for Precast Concrete Grease Interceptors
- K. Uniform Plumbing Code (UPC)

1.04 SUBMITTALS

- A. Design calculations and detailed drawings of component sections signed by a registered California Professional Engineer. Show dimensions and materials of construction by ASTM reference and grade.
- B. Shop drawings of grating, grating frame embeds, covers, and all appurtenances
- C. Shop drawings indicating the installation procedures and dimensions and the location of all joints or welded strips
- D. Results of testing required per paragraph of this specification entitled "Quality Assurance"
- E. Qualifications of engineer designing the precast concrete structure
- F. Recommendations for inlet and outlet seals and watertight caulking

1.05 QUALITY ASSURANCE

- A. Precast concrete producer shall demonstrate adherence to the standards set forth in the National Precast Concrete Association Quality Control Manual.
- B. The precast concrete producer shall have been in the business of producing precast concrete products similar to those specified, for a minimum of 5 years. The precast concrete producer shall maintain a permanent quality control department or retain an independent testing agency on a continuing basis. The agency shall issue a report, certified by a licensed engineer, detailing the ability of the precast concrete producer to produce quality products consistent with industry standards.
- C. The precast concrete producer shall show that the following tests are performed in accordance with the ASTM standards indicated. Tests shall be performed for each 150 cu. yd. of concrete placed, but not less frequently than once per week.
 - 1. Slump: C143
 - 2. Compressive Strength: C31, C192, C39
 - 3. Air Content (when air-entrained concrete is being used): C231 or C173
 - 4. Unit Weight: C138
- D. The District may place an inspector in the plant when the products covered by this specification are being manufactured.

PART 2 PRODUCTS

2.01 GREASE INTERCEPTOR

- A. Comply with ASTM C1613.
- B. Cement: Type II or V per ASTM C 150
- C. Design loads: Comply with requirements of ASTM C890 using HS-20 live load.

- D. The interior of the precast unit shall be sealed with a protective coating.
- E. Each grease interceptor shall be permanently and legibly marked with the Manufacturer's name or trademark, model number and UPC certification mark.

2.02 ACCESSORIES

- A. Provide cast iron frames and covers per requirements of Section 03461.
- B. Provide joint sealing compound at all joints per requirements of Section 03461.

PART 3 EXECUTION

3.01 EARTHWORK

- A. Excavation and backfill for precast concrete vaults shall be in accordance with Section 02200 and the requirements herein.
- B. The Contractor shall prepare an excavation large enough to accommodate the structure and permit grouting of openings and backfilling operations.
- C. The bottom of the structure shall be placed on 12 inches of compacted, crushed rock sub-base, graded level and to the proper elevation as shown on the plans.

3.02 INSTALLATION

- A. Grease interceptors shall be installed per Section 03462.

3.03 FIELD QUALITY CONTROL

- A. Vacuum test installed grease interceptor tanks per ASTM C1613.

END OF SECTION

SECTION 09810

EPOXY COATING FOR SEWER MANHOLE REHABILITATION

PART 1 GENERAL

1.01 SECTION INCLUDES

- A. Rehabilitation of existing sanitary sewer manholes
- B. Monolithic spray applied epoxy coating covering all interior surfaces of existing manholes, including bench and invert
- C. Manhole frame and cover replacement

1.02 RELATED REQUIREMENTS

- A. Section 03461, Precast Reinforced Concrete Manholes

1.03 REFERENCED STANDARDS

- A. ASTM: The published standards of the American Society for Testing and Materials, West Conshohocken, PA.
 - 1. ASTM D4263: Standard Test Method for Indicating Moisture in Concrete by the Plastic Sheet Method
 - 2. ASTM D4414: Standard Practice for Measurement of Wet Film Thickness by Notched Gages
 - 3. ASTM D4541: Standard Test Method for Pull-off Strength of Coatings Using Portable Adhesion Testers.
- B. NACE: The published standards of National Association of Corrosion Engineers (NACE International), Houston, TX.
 - 1. NACE SP 0188: Discontinuity (Holiday) Testing of New Protective Coatings on Conductive Substrates
 - 2. NACE No. 6/SSPC SP-13: Surface Prep of Concrete
- C. SSPC: The published standards of the Society of Protective Coatings, Pittsburgh, PA.
- D. SCAQMD rules and regulations

1.04 SUBMITTALS

- A. The following items shall be submitted in accordance with the General Requirements and Section 01330 (Submittal Procedures):

MOULTON NIGUEL WATER DISTRICT

1. A certification letter from the manufacturer of the manhole rehabilitation system products stating that the products to be used are compatible with each other and appropriate for the intended use.
2. Technical data sheet on each product used, including ASTM test results indicating the product conforms to and is suitable for its intended use per these specifications.
3. Documentation that all materials used comply with SCAQMD rules and regulations.
4. Material Safety Data Sheets (MSDS) for each product used.
5. The manufacturer's published instructions for applying the coating system, including conditions, procedures, and qualities that may adversely affect the coating system.
6. Four (4) project references with contact names and phone numbers that used the submitted coating material for coating sewer manholes. The total number of manholes shall be at least 100. All projects shall be at least three (3) years old with no coating failures.

B. Applicator Qualifications:

1. Manufacturer certification that Applicator has been trained and approved in the handling, mixing, and application of the products to be used
2. Certification by the protective coating manufacturer that the equipment to be used for applying the products are recommended or have been approved and Applicator personnel have been trained and certified for proper use of the equipment
3. Five (5) recent references for the Applicator of projects of similar size and scope indicating successful application on underground concrete or masonry substrates of the specified 100% solids, high-build solvent-free epoxy coating and repair material
4. Proof of any necessary federal, state, or local permits or licenses necessary for the project

C. Design details and descriptions for the systems, processes, and equipment to be used in site and surface preparation, application, and testing.

D. A detailed plan for the removal of loose material from the interior sides of the manholes. The plan shall include the tool and equipment to be used in the removal and cleaning process; the method to be used to prevent the material from entering the sewer; the method for removal and disposal; and the final disposal location.

E. Project specific submittals and procedures for manhole repair materials, including application, cure time, and surface preparation procedures which permit optimum bond strength with the epoxy coating

F. Method statements and design procedures when confined space entry, flow diversion, debris removal, or bypass is necessary to perform the specified work.

G. Or Equal Submittal: To be considered as an equal product, said product must meet or exceed the minimum standards included in this specification and either have successfully passed the Los Angeles County "Evaluation of Protective Coatings for Concrete" corrosion testing program and SSPWC 210.2.3.3 (Greenbook "Pickle Jar" Chemical Resistance test) or have been in use in a Moulton Niguel Water District structure of similar environment for at least five (5) years successfully and without failure in the sole and final opinion of the District.

1.05 QUALITY ASSURANCE

- A. Concrete repair material and protective epoxy coating shall be applied by a Certified Applicator of the protective coating manufacturer.
- B. Applicator shall initiate and enforce quality control procedures consistent with applicable ASTM, NACE, SSPC standards, and the protective coating manufacturer's recommendations.
- C. The Contractor shall provide the District a minimum of three (3) days advance notice of the start of any field surface preparation or coating application work.
- D. A Coating Inspector will be provided by the District (District Coating Inspector). The District Coating Inspector will observe daily operations, procedures, and final product testing to ensure adherence to the specifications by Applicator. All work shall be done in the presence of the District Coating Inspector.
- E. Inspection by the District shall not relieve the Contractor of its responsibility to perform the work in accordance with this Specification.
- F. Applicator shall conform to all local, state, and federal regulations including those set forth by OSHA, RCRA, the EPA, and any other applicable authorities.
- G. All surface preparation, coating application, and repair of defective work, if necessary, shall be performed by a California licensed Contractor that is also a manufacturer approved and certified Applicator for the approved epoxy being applied. All reference and requirements herein to and for Applicator shall also apply to the Contractor.
- H. No products shall be allowed on the construction site, which do not conform to South Coast Air Quality Management District (SCAQMD) rules and regulations. Materials shall be delivered unopened to the jobsite in their original containers bearing the manufacturer's label, completely identifying the contents, date of manufacture, volatile organic compounds (VOCs) as required by the SCAQMD, and listing directions for proper use. Materials exceeding the storage life recommended by the manufacturer shall be removed from the jobsite.

1.06 DELIVERY, STORAGE, AND HANDLING

- A. Materials are to be kept dry, protected from weather, and stored under cover.
- B. Protective coating materials are to be stored between 50 deg F and 90 deg F. Do not store near flame, heat, or strong oxidants.
- C. Protective coating materials are to be handled according to their material safety data sheets.

1.07 WARRANTY

- A. The Contractor and epoxy coating manufacturer, jointly, shall warrant all work against defects in materials and workmanship for a period of not less than five (5) years, unless otherwise noted, from the date of final acceptance of the project.

MOULTON NIGUEL WATER DISTRICT

1. The Contractor shall, within a reasonable time after receipt of written notice thereof, repair defects in materials and workmanship which may develop during the warranty period, and any damage to other work caused by such defects or the repairing of same, at his/her own expense and at no additional cost to the District.
 2. A Coating Inspector hired by the District shall conduct the field testing and inspection in this specification for all warranty repairs. The Coating Inspector shall observe and document warranty repairs to ensure adherence to the specifications. All repair work shall be done to the satisfaction of the Coating Inspector.
- B. The Contractor shall accompany the District to inspect the manholes each year for the first five (5) years after project completion.
1. A total of five (5) inspections will be required. The manholes to be inspected shall be chosen by the District, and could include all of them, or the District selection.
 2. The District will be responsible for opening the manholes, providing traffic control, and performing the inspection and testing inside the manhole.
 3. The inspection will include thorough visual inspection using the latest District inspection form to identify pin holes, infiltration, corrosion, delamination, or other product or installation defects.
 4. The District may, at its sole discretion, choose to perform holiday testing and bond strength testing. Any defects found in materials or workmanship as warranted shall be corrected by the Contractor at no additional cost to the District.

PART 2 PRODUCTS

2.01 GENERAL

- A. Infiltration sealant, concrete repair material, and protective epoxy coating shall be compatible for use as a complete manhole rehabilitation system.
- B. Materials and supplies provided shall be the standard products of the manufacturer or products standardly used and certified by the epoxy manufacturer as compatible with the approved epoxy top coat.

2.02 INFILTRATION SEALANT

- A. Small active leaks in the manhole shall be sealed with a material that is compatible with the repair products and suitable for top coating with the epoxy protective coating.
- B. Sealant shall be hydrophobic polyurethane or epoxy injection grout certified to be compatible with the approved epoxy to be installed and shall be submitted for review and approval as part of the epoxy submittal package.

2.03 REPAIR MATERIAL

- A. Repair work includes re-pointing, filling, and repairing non-leaking holes, cracks, and spalls in the manhole walls, bench, slabs, and channel prior to installation of the epoxy coating product(s).

- B. Repair material shall be quick-setting epoxy mastic or cementitious material capable of a two inch vertical hang. The material shall be trowel-on or spray-on, depending on the concrete condition and whether application is on vertical or horizontal surfaces.
- C. All repair materials shall be submitted for review and acceptance and shall be certified by the finish epoxy manufacturer as fully compatible with the finish epoxy.

2.04 PROTECTIVE EPOXY COATING

- A. Protective epoxy coating shall be a 100% solids, solvent-free epoxy coating.
- B. The coating shall have bond strength to concrete equal to or greater than the tensile strength of concrete.
- C. The final cured coating shall be resistant to environments with a pH between 1.0 and 13.0 without degradation.
- D. Total dry film thickness (DFT) = 125 mils

2.05 COATING APPLICATION EQUIPMENT

- A. Protective epoxy coating shall be applied with manufacturer approved heated plural component spray equipment. Spray equipment shall be dedicated for application of the specified protective epoxy coating.
- B. Hard to reach areas, sealant and repair material application, and touch-up may be performed using hand tools.

PART 3 EXECUTION

3.01 GENERAL

- A. Appropriate actions shall be taken to comply with local, state, federal regulatory, and other applicable agencies with regard to environment, health and safety.
- B. Installation of the protective coating shall not commence until the concrete substrate has properly cured and been prepared in accordance with these specifications.
- C. During surface preparation and application of repair and epoxy materials, care must be taken so that no loose material or chemicals enter the sewer. Waste disposal shall be the sole responsibility of the Contractor.
- D. The Contractor shall furnish all tools, equipment, materials, and supplies and shall perform all labor required to complete the protective coating of all specified surfaces. This work shall include all surface preparation, pretreatment, coating application, protection of surfaces not to be coated, cleanup, and appurtenant work, in accordance with the requirements of the Contract Documents.

3.02 MANHOLE FRAME AND COVER REPLACEMENT

- A. Remove and dispose of existing manhole frame and cover prior to application of coating.
- B. Remove existing asphalt or concrete pavement as necessary and entire concrete collar, if existing, for frame and cover removal.
- C. Install new manhole frame and cover per District Standard Drawings and per requirements of Section 03461.
- D. Patch pavement surrounding manhole with temporary bagged cold mix asphalt. The use of bulk cold mix asphalt will not be permitted.

3.03 SURFACE PREPARATION

- A. Applicator shall inspect all surfaces specified to receive a protective coating prior to surface preparation. Applicator shall notify the District of any noticeable disparity in the surfaces which may interfere with the proper preparation or application of the repair mortar and protective coating.
- B. If areas of exposed structural steel are encountered, the Contractor shall contact the District immediately for further inspections and instructions.
- C. Minor infiltration shall be sealed with a material meeting the requirements of this specification. If running and gushing leaks (greater than one gallon per minute) are encountered, the Contractor shall contact the District immediately for further inspections and instructions.
- D. All contaminants including oils, grease, unsound or incompatible existing coatings, waxes, form release, curing compounds, efflorescence, sealers, salts, or other contaminants shall be removed.
- E. All concrete that is not sound or has been damaged by chemical exposure shall be removed up to sound concrete or replaced. Sound concrete is defined as concrete prepared to a level of and in accordance with NACE No. 6/SSPC SP-13 and International Concrete Restoration Institute Concrete Service Preparation Level 4 (ICRI CSP Level 4).
- F. Surface preparation method(s) should be based upon the conditions of the substrate and the requirements of the epoxy protective coating to be applied.
- G. Surfaces to receive protective coating shall be cleaned and abraded to produce a surface with adequate profile and porosity to provide a strong bond between the protective coating and the substrate. Surface preparation method, or combination of methods, that may be used include high pressure water cleaning, high pressure water jetting, abrasive blasting, shot-blasting, grinding, scarifying, acid etching, detergent water cleaning, hot water blasting and others as described in NACE No. 6/SSPC SP-13. Whichever method(s) are used, they shall be performed in a manner that provides a uniform, sound, clean, neutralized surface that is not excessively damaged.

- H. The surface, after preparation, shall be inspected and accepted by the District Coating Inspector. Following acceptance, lining of the manhole must be completed within the following two calendar days. A pH test shall be conducted in the presence of the District Coating Inspector and a pH of 7 or greater shall be required prior to coating.

3.04 APPLICATION OF REPAIR MATERIALS

- A. The Contractor shall repair all uneven surfaces, surfaces with exposed aggregate that protrudes more than ½ inch above the surrounding concrete, or has holes more than ½ inch deep.
- B. Repair materials shall be trowel or spray applied utilizing proper equipment on damaged surfaces.
- C. Repair materials shall be applied to provide a smooth surface with an average profile equivalent to coarse sandpaper to optimally receive the protective coating. No bugholes or honeycomb surfaces should remain after the final trowel procedure of the repair mortar. Use a brush finish after troweling to provide a coarse sandpaper-type finish. Repaired surface shall be ±1/16-inch level with the original surface.
- D. The repair materials shall be cured according to the manufacturer's recommendations.

3.05 APPLICATION OF PROTECTIVE EPOXY COATING

- A. Application procedures shall conform to the recommendations of the protective coating manufacturer, including material handling, mixing, environmental controls during application, safety, and spray equipment.
- B. Applicator shall test prepared surface for moisture prior to application of protective epoxy coating in accordance with ASTM D4263. If required, additional drying of concrete shall be done by removal of the moisture sources and ventilation or dehumidification. The surface moisture level immediately prior to coating shall not exceed the manufacturer's recommended moisture level for application of the protective epoxy coating.
- C. Applicator shall test prepared surfaces for pH and other manufacturer recommended physical properties immediately prior to application of the epoxy coating. These properties shall be as recommended by the manufacturer. The pH shall be 7 or greater.
- D. The spray equipment shall be specifically designed to accurately ratio and apply the specified protective coating materials and shall be regularly maintained and in proper working order.
- E. Airless spray application equipment approved by the coating manufacturer shall be used to apply each coat of the protective coating. Air assisted spray application equipment may be acceptable, especially for thinner coats (<10 mils), only if the air source is filtered to completely remove all oil and water.
- F. If necessary, subsequent top coating or additional coats of the protective coating should occur as soon as the basecoat becomes tack free, ideally within 12 hours but no later than the manufacturer stated and approved recoat window for the specified product. Additional surface preparation procedures will be required if this recoat window is exceeded.

- G. The coating shall be installed on the entire manhole including the shelf and trough of the base to 1-inch above the water level. The coating shall not be applied to the cast iron frame and cover and shall not be applied to the trough below an elevation 1-inch above the water level. All coating termination shall be keyed into a ¼-inch by ¼-inch mechanically scored groove. The coating termination at the manhole trough shall be at the vertical portion of the trough 1-inch above the water level. If the frame and cover is to be replaced, the coating shall include the horizontal surface of the uppermost grade ring.
- H. For manholes that specify shelf coating only, the shelf and trough of the base to 1-inch above the water level shall be coated. The coating shall also be applied 6-inches above the shelf on the vertical wall of the manhole section.

3.06 FIELD TESTING AND INSPECTION

- A. Testing and inspection shall be conducted by the District Coating Inspector. The Contractor shall provide access, confined space support and equipment, and traffic control necessary for all testing and inspection activities to be performed by the District Coating Inspector.
- B. Any portion of the coating that does not satisfactorily pass the inspection and testing requirements shall be repaired or replaced by the Contractor at no additional cost to the District. Further, all District coordination, inspection, testing, and other costs related to failed preparation, application, and testing shall be at the expense of the Contractor.
- C. Testing and inspection to be conducted by the District Coating Inspector will include, but not be limited to, the following:
 - 1. Surface Preparation Inspection: The District Coating Inspector will examine the hydro or abrasive blasting equipment used for surface preparation, and will identify areas of insufficient or inadequate cleaning or surface profile, prior to the application of any repair material or protective coatings. The Contractor shall notify the District and the Coating Inspector of the time and date for inspection and approval two working days prior to completing the surface preparation of each manhole and prior to application of the coating.
 - 2. Ambient Conditions: The District Coating Inspector will monitor the air and surface temperatures, relative humidity, and dew point periodically during coating operations.
 - 3. Moisture Content: The moisture content in the concrete prior to application shall be less than that recommended by the manufacturer. The District Coating Inspector will use a "blotter test", or other test method, to determine the moisture content.
 - 4. Equipment Inspection: The District Coating Inspector will check that the plural component spray equipment is clean and properly calibrated prior to protective epoxy coating application.
 - 5. Compressed Air Cleanliness: The District Coating Inspector will check that the compressed air supply used for operations such as blast cleaning or substrate blowing is adequately free of moisture and oil contaminates.
 - 6. Mixing: The District Coating Inspector will observe the mixing of coatings to assure that all components are added and proportioned correctly. The Inspector will check that materials used are approved and that their pot or shelf lives have not been exceeded.

7. **Thickness Testing:** During coating application, a wet film thickness gage, such as those available through Paul N. Gardner Company, Inc., or approved equal, meeting ASTM D4414 - Standard Practice for Measurement of Wet Film Thickness of Organic Coatings by Notched Gages, will be used to ensure a monolithic coating and uniform thickness during application.
8. **Holiday Testing (Spark Testing):** After the protective coating has set hard to the touch, it will be inspected with high-voltage holiday detection equipment in accordance with NACE Recommended Practice for Discontinuity (Holiday) Testing of Protective Coatings (SP 0188-99). Surfaces shall first be dried; an induced holiday will then be made on to the coated concrete surface and will serve to determine the minimum/maximum voltage to be used to test the coating for holidays at that particular area. The spark tester will be initially set at 100 volts per 1 mil (25 microns) of film thickness applied but will be adjusted as necessary to detect the induced holiday. All detected holidays will be marked by the District Coating Inspector. The Contractor shall repair/touch-up holidays in accordance with the protective coating manufacturer's recommendations.
9. **Bond Strength Testing:** Measurement of bond strength of the protective coating to the substrate will be made by the District Coating Inspector in accordance with ASTM D4541. The number of manholes and locations inside the manholes to be tested shall be determined by the District after application of coating. Each manhole tested shall have one or more 20 mm dollies fixed and pulled in accordance with ASTM D4541, using an Elcometer 106 instrument. The adhesion pulls shall exceed 200 psi or concrete failure with more than 50% of the subsurface adhered to the coating. For each test that fails, two additional tests will be performed in the same manhole at locations chosen by the District Coating Inspector. Further bond tests may be performed by the District Coating Inspector to determine the extent of potentially deficient bonded areas. The Contractor shall repair all bond strength test sites in accordance with the manufacturer's recommendations. If two consecutive dollies in the same manhole fail, the liner shall be removed and replaced at the expense of the Contractor.

The District Coating Inspector shall determine whether or not a sample shall be scored prior to initiating the Bond Strength Test.
10. **Visual Inspection:** A visual inspection will be made by the Inspector and manufacturer's representative using the latest NASSCO standard inspection form (if available) or District inspection form. Any deficiencies in the finished coating will be marked and repaired according to the procedures set forth herein by Applicator.

END OF SECTION

SECTION 09900

PAINTING AND COATING

PART 1 GENERAL

1.01 SECTION INCLUDES

- A. Field painting and coatings for non-buried, exposed surfaces
 - 1. Ferrous metal surfaces
 - 2. Galvanized and non-ferrous metal surfaces, where indicated
 - 3. Aluminum in contact with dissimilar materials
 - 4. Plastic surfaces, where indicated

1.02 RELATED REQUIREMENTS

- 1. Section 15056, Ductile-Iron Pipe and Fittings
- 2. Section 15100, Manual Valves
- 3. Section 15139, Fire Hydrants
- 4. Section 15151, Potable Water, Recycled Water, and Wastewater Facilities Identification

1.03 DEFINITIONS

- A. DFT: Dry Film Thickness, mils
- B. Exterior exposure: Outdoors; with or without overhead cover
- C. Ferrous: Metal material containing or consisting of iron (e.g. ductile iron, cast iron, steel)
- D. Interior exposure: Inside a building, vault, etc.
- E. Mil: Thousandth of an inch
- F. Paint: All coating systems materials, which includes pretreatments, primers, emulsions, epoxies, enamels, varnish, stain, sealers and fillers, and other applied materials whether used as prime, intermediate or finish coats

1.04 REFERENCED STANDARDS

- A. The National Association of Pipe Fabricators (NAPF)
 - 1. NAPF 500: Surface Preparation Standard For Ductile Iron Pipe and Fittings in Exposed Locations Receiving Special External Coatings and/or Special Internal Linings
- B. NSF International
 - 1. NSF 61: Drinking Water Systems Components – Health Effects

- C. SSPC: The Society for Protective Coatings
 - 1. SSPC-SP2: Hand Tool Cleaning
 - 2. SSPC-SP6: Commercial Blast Cleaning
 - 3. SSPC-SP10: Near-White Blast Cleaning
 - 4. SSPC-SP16: Brush-off Blast Cleaning Non-Ferrous Metals

1.05 SUBMITTALS

- A. Product data sheets:
 - 1. Manufacturer's technical information, surface preparation instructions, and application instructions for product
 - 2. Each product shall be listed and cross-referenced to the specific coating system.
 - 3. Color charts and sample for each coating system
 - 4. Safety data sheets for each product
- B. Certifications: Letter from manufacturers verifying that the factory applied prime coats are compatible with specified finish coatings
- C. Contractor safety plan
- D. Manufacturer Experience: Submit reference documentation for submitted coating system. Provide list of utility or industrial installations painted, responsible officials, contact information, and date.
- E. Applicators Qualifications: Submit name and experience record of the painting applicator. Provide list of utility or industrial installations painted, responsible officials, architects, or engineers concerned with the project, contact information, date, and the approximate contract price.

1.06 QUALITY ASSURANCE

- A. Manufacturer Qualifications: Minimum of five similar installations with the submitted coating system, which have been in service for more than five years in the United States of America.
- B. Applicator Qualifications: Minimum of five utilities or industrial installation of a similar size or larger, all in Southern California within the last five years.
- C. Permits: All work shall conform to the specifications and requirements of the city having jurisdiction, and other agencies involved. The Contractor shall keep a copy of all the required permits on the job site and comply with all the terms and conditions of said permits.

1.07 PRODUCT DELIVERY, STORAGE AND HANDLING

- A. Delivery of Materials: All materials shall be delivered to the job site in original, new and unopened packages and containers bearing the manufacturer's name and label, and the following information:
 - 1. Name or title of material, stock number, color, and date of manufacture

2. Contents by volume, for major pigment and vehicle constituents
 3. Thinning instructions where recommended, and Application instructions
- B. Storage of Materials:
1. Conform to manufacturer's written recommendations including, but not limited to, product shelf life and recommended storage temperature.
 2. Materials not in actual use shall be stored in tightly covered containers. Containers used in storage, mixing, and application of paint shall be maintained in a clean condition, free of foreign materials and residue.

1.08 AMBIENT CONDITIONS

- A. Water-base paints shall be applied only when the temperature of surfaces to be painted and the surrounding air temperatures are between 55-degrees F and 90-degrees F unless otherwise permitted by the paint manufacturer's printed instructions.
- B. Other paints shall be applied only when the temperature of the surfaces to be painted and the surrounding air temperatures are between 65-degrees F and 95-degrees F, unless otherwise permitted by the paint manufacturer's printed instructions.
- C. Paint shall not be applied in snow, rain, fog, or mist, when the relative humidity exceeds 85 percent, or to damp or wet surfaces, unless specifically permitted by the manufacturer's printed instructions.
- D. Painting may be continued during inclement weather only if the areas and surfaces to be painted are enclosed and heated within the temperature limits specified by the paint manufacturer during application and drying periods, and there is no danger of condensation on the surfaces being painted.
- E. Adequate illumination and ventilation shall be provided in all areas where painting operations are in progress.

PART 2 PRODUCTS

2.01 PAINT MATERIALS

- A. The best grade of the various types of coating suitable for the intended use as regularly manufactured by acceptable paint material manufacturers shall be provided.
- B. Primers produced by the same manufacturer as the intermediate and finish coats shall be provided. Use only thinners recommended by the paint manufacturer, and use only to recommended limits. The District's acceptance shall be obtained prior to thinning any material.
- C. Provide coating systems that withstand normal washing as required for removing grease, oil, chemicals, etc., without showing discoloration, loss of gloss, staining, or other damage.
- D. Provide coating materials suitable for the intended use and recommended by the manufacturer for the intended service.

- E. Lead content shall not exceed amount permitted by federal, state, and local government laws and regulations.
- F. Coatings specified for application on submerged concrete or metal in contact with potable water shall conform to the requirements of NSF 61.
- G. Coatings shall comply with South Coast Air Quality Management District Requirements.

2.02 EPOXY COATING

- A. Type:
 - 1. Amine-type epoxy coating
 - 2. Self-priming
- B. Finish: Semi-gloss or satin
- C. Percent solids content: 66 to 75-percent

2.03 URETHANE COATING

- A. Type: Aliphatic acrylic polyurethane coating
- B. Finish: Gloss or semi-gloss
- C. Percent solids content: 66 to 70-percent

2.04 HIGH-SOLIDS EPOXY COATING

- A. Type:
 - 1. Amine-type epoxy coating
 - 2. Self-priming
- B. Finish: Gloss or semi-gloss
- C. Percent solids content: 98 to 100-percent

2.05 SULFIDE-RESISTANT EPOXY COATING

- A. Type:
 - 1. Amine-type epoxy coating
 - 2. Self-priming
 - 3. Resistant to 98-percent sulfuric-acid
- B. Percent solids content: 100-percent

2.06 BITUMINOUS MASTIC COATING

- A. Type:

1. Bituminous tar mastic coating
 2. Self-priming
- B. Percent solids content: 69-percent (minimum)

PART 3 EXECUTION

3.01 EXAMINATION

- A. The Contractor and his applicator shall examine the areas and conditions under which painting work is to be performed and notify the District in writing of conditions detrimental to the proper and timely completion of the Work. The Contractor shall not proceed with the work until unsatisfactory conditions have been corrected in a manner acceptable to the District.
- B. The Contractor shall not paint over dirt, rust, scale, grease, moisture, scuffed surfaces, or conditions otherwise detrimental to the formation of a durable paint film.

3.02 PROTECTION OF IN-PLACE CONDITIONS

- A. Protect all items not to be painted from cleaning, blasting, and new painting splatters and overspray:
1. Remove, mask, or otherwise protect hardware, grease fittings, lighting fixtures, switchplates, stainless steel, brass, copper, bronze, galvanized, and aluminum surfaces, machined surfaces, couplings, shafts, bearings, nameplates on machinery, and other surfaces not specified elsewhere to be painted.
 2. Provide drop cloths to prevent paint materials from falling on or marring adjacent surfaces.
 3. Protect working parts of mechanical and electrical equipment from damage during surface preparation and painting process.
 4. Mask openings in motors to prevent paint and other materials from entering.
 5. Protect surfaces adjacent to or downwind of Work area from overspray.
 6. After painting operations begin in a given area, broom cleaning will not be allowed; cleaning shall then be done only with commercial vacuum cleaning equipment.
 7. Thoroughly clean all accidental spills, splatters, and overspray. Any damage or stains to finishes, equipment, or concrete shall be restored to original condition to the District's satisfaction.
 8. "Wet Paint" signs shall be provided as required to protect newly painted finishes. All temporary protective wrapping provided for protection shall be removed after completion of painting operations.

3.03 SURFACE PREPARATION

- A. Perform surface preparation per the coating system schedule specified herein.

- B. Conform to manufacturer's written requirements for each particular substrate. If proper application of the coating system requires a more stringent surface preparation than is specified herein, comply with manufacturer's requirements at no additional cost to the District.
- C. Surfaces to be painted shall be cleaned before applying paint or surface treatments. Oil and grease shall be removed with clean cloths and cleaning solvents prior to mechanical cleaning. Remove all sharp edges, burrs, and weld spatter.
- D. The cleaning and painting shall be coordinated so that dust and other contaminants from the cleaning process will not fall in wet, newly painted surfaces.
- E. Before painting is started in any area, it shall be broom cleaned and excessive dust shall be removed.
- F. Do not sandblast or prepare more surface area than can be coated in one day or less.

3.04 MATERIALS PREPARATION

- A. Tinting:
 - 1. Undercoats shall be tinted to match the color of the finish coat, but provide sufficient difference in shade of undercoats to distinguish each separate coat.
 - 2. A code number shall be provided to identify material tinted by the manufacturer.
- B. Mixing:
 - 1. Coating materials produced by different manufacturers shall not be mixed, unless otherwise permitted by the manufacturer's instructions.
 - 2. Painting materials shall be mixed and prepared in strict accordance with the manufacturer's written directions.
 - 3. All materials shall be stirred before application to produce a mixture of uniform density and as required during the application of the materials. Any film that may form on the surface shall not be stirred into the material. The film shall be removed and, if necessary, the material shall be strained before using.
 - 4. The Contractor shall mix only in mixing pails placed in a suitably sized non-ferrous or oxide resistant metal pans to protect concrete floor from splashes or spills which could stain exposed concrete or react with subsequent finish floor material. The Contractor shall thoroughly clean all accidental spills and any damage to finish or concrete shall be restored to original condition to the District's satisfaction.
 - 5. Paint shall be mixed and applied only in containers bearing accurate product name of material being mixed or applied.

3.05 APPLICATION

- A. Apply coatings by brush, roller, air spray, or airless spray in accordance with manufacturer's written instructions.
 - 1. If the manufacturer of the coating system requires a more stringent dry film thickness than is specified herein, comply with manufacturer's requirements at no additional cost to the District.

MOULTON NIGUEL WATER DISTRICT

2. The number of coats and paint film thickness required is the same regardless of the application method.
 3. The first-coat of material shall be applied to surfaces that have been cleaned, pretreated or otherwise prepared for painting as soon as practicable after preparation and before subsequent surface deterioration.
 4. Sufficient time between successive coatings shall be allowed to permit proper drying per the manufacturer's written instructions. The Contractor shall not recoat until paint has dried to where it feels firm, does not deform or feel sticky under moderate thumb pressure, and the application of another coat of paint does not cause lifting or loss of adhesion of the undercoat.
 5. Do not double back with spray equipment for the purpose of building up film thickness of 2 coats in one pass.
 6. All brush coats shall be brushed-out and worked onto the surfaces in an even film.
 7. Work shall be free of cloudiness, spotting, holidays, brush marks, sags, ropiness, runs, bridges, shiners, laps, or other imperfections.
- B. Provide complete coverage to dry film mil thickness specified.
1. In situations of discrepancy between manufacturer's square footage coverage rates and mil thickness, mil thickness requirements govern.
 2. When color or undercoats show through, apply additional coats until paint film is of uniform finish and color. The Contractor shall completely cover to provide an opaque, smooth surface of uniform finish, color, appearance, and coverage.
 3. The Contractor shall insure that all surfaces, including edges, corners, crevices, welds, and exposed fasteners receive a film thickness equivalent to that of flat surfaces.
- C. Temporarily remove pipe clamps and hangers prior to painting installed pipe.
- D. Provide all necessary air monitoring, ventilation, confined space training, and personal protection equipment.
- E. Conform to all federal, state, local, and health codes/requirements.

3.06 COATING SYSTEMS SCHEDULE

- A. Provide the following coating systems for all of the following surfaces:
- B. System "1": Ferrous Metals, Interior Exposure, Non-Immersed:
 - 1. Use on the following items or areas:
 - a. Interior exposed ferrous metals including structural steel and miscellaneous metals
 - b. Interior exposed ferrous piping, fittings, valves, appurtenances, and pipe supports
 - 2. Surface Preparation:
 - a. Steel: SSPC-SP 6 Commercial Blast
 - b. Ductile/cast iron: NAPF 500 Solvent Cleaning and Abrasive Blast Cleaning
 - 3. Coating Material and Dry Film Thickness
 - a. Primer: Epoxy; 1 coat, 3.0 to 5.0 dry mils
 - b. Intermediate: Epoxy; 1 coat, 3.0 to 5.0 dry mils
 - c. Finish: Epoxy; 1 coat, 4.0 to 6.0 dry mils
 - 4. Field Touchup:
 - a. Preparation: Mechanically grind clean all visibly corroded surfaces per SSPC-SP 11 Bare Metal Power Tool Cleaning and remove all corrosion.
 - b. Coating: High-solids epoxy; 1 coat, 3.0 to 5.0 dry mils
- C. System "2": Ferrous Metals, Exterior Exposure:
 - 1. Use on the following items or areas:
 - a. Exterior exposed ferrous metals including structural steel and miscellaneous metals
 - b. Exterior exposed ferrous piping, fittings, valves, appurtenances, and pipe supports
 - 2. Surface Preparation:
 - a. Steel: SSPC-SP 6 Commercial Blast
 - b. Ductile/cast iron: NAPF 500 Solvent Cleaning and Power Tool Cleaning
 - 3. Coating Material and Dry Film Thickness
 - a. Primer: Epoxy; 1 coat, 3.0 to 5.0 dry mils
 - b. Intermediate: Epoxy; 1 coat, 4.0 to 6.0 dry mils
 - c. Finish: Urethane; 1 coat, 3.0 to 5.0 dry mils
 - 4. Field Touchup:
 - a. Preparation: Mechanically grind clean all visibly corroded surfaces per SSPC-SP 11 Bare Metal Power Tool Cleaning and remove all corrosion.
 - b. Coating: High-solids Epoxy; 1 coat, 3.0 to 5.0 dry mils
- D. System "3": Ferrous Metals, Immersed (potable or recycled water):
 - 1. Use on the following items or areas:

- a. Immersed ferrous metals including structural steel and miscellaneous metals
 - b. Immersed ferrous piping, fittings, valves, appurtenances, and pipe supports
 2. Surface Preparation:
 - a. Steel: SSPC-SP 10 Near-White Blast Cleaning
 - b. Ductile/cast iron: NAPF 500 Solvent Cleaning and Abrasive Blast Cleaning
 3. Coating Material and Dry Film Thickness
 - a. Option 1: Complete System: High-solids epoxy; 1 coat, 16.0 to 30.0 dry mils
 - b. Option 2: Complete System: Epoxy; 3 coats, 5.0 to 6.0 dry mils (each)
 4. Field Touchup:
 - a. Preparation: Mechanically grind clean all visibly corroded surfaces per SSPC-SP 11 Bare Metal Power Tool Cleaning and remove all corrosion
 - b. Coating: High-solids epoxy; 1 coat, 3.0 to 5.0 dry mils
- E. System "4": Ferrous Metals, Immersed (sewer):
 1. Use on the following items or areas:
 - a. Immersed ferrous metals including structural steel and miscellaneous metals
 - b. Immersed ferrous piping, fittings, valves, appurtenances, and pipe supports
 2. Surface Preparation:
 - a. Steel: SSPC-SP 10 Near-White Blast Cleaning
 - b. Ductile/cast iron: NAPF 500 Solvent Cleaning and Abrasive Blast Cleaning
 3. Coating Material and Dry Film Thickness
 - a. Complete System: Sulfide-resistant epoxy; 1 coat, 30.0 to 40.0 dry mils
 4. Field Touchup:
 - a. Preparation: Mechanically grind clean all visibly corroded surfaces per SSPC-SP 11 Bare Metal Power Tool Cleaning and remove all corrosion.
 - b. Coating: High-solids epoxy; 1 coat, 3.0 to 5.0 dry mils
- F. System "5": Galvanized Metal and Non-Ferrous Metal, Exterior Exposure:
 1. Use on the following items or areas:
 - a. Galvanized metal surfaces where indicated
 2. Surface Preparation: SSPC-SP 16: Brush-Off Blast Cleaning for Non-Ferrous Metals
 3. Coating and Dry Film Thickness
 - a. Primer: Epoxy; 1 coat, 3.0 to 5.0 dry mils
 - b. Finish: Urethane; 1 coat, 3.0 to 5.0 dry mils
 4. Field Touchup:
 - a. Preparation: Mechanically grind clean all visibly corroded surfaces per SSPC-SP 11 Bare Metal Power Tool Cleaning and remove all corrosion.

MOULTON NIGUEL WATER DISTRICT

- b. Coating: High-solids epoxy; 1 coat, 3.0 to 5.0 dry mils

- G. System "6": All Aluminum in Contact with Dissimilar Materials:
 - 1. Use on the following items or areas:
 - a. Aluminum in contact with steel, stainless steel, or other metals
 - b. Aluminum in contact with concrete
 - 2. Surface Preparation: SSPC-SP 16: Brush-Off Blast Cleaning for Non-Ferrous Metals
 - 3. Coating Material and Dry Film Thickness
 - a. Option 1: Complete system: Epoxy; 2 coats, 5.0 to 6.0 dry mils (each)
 - b. Option 2: Complete system: Bituminous mastic; 1 coat, 10.0 to 20.0 dry mils
 - 4. Field Touchup:
 - a. Preparation: Mechanically grind clean all visibly corroded surfaces per SSPC-SP 11 Bare Metal Power Tool Cleaning and remove all corrosion.
 - b. Coating: High-solids epoxy; 1 coat, 3.0 to 5.0 dry mils

- H. System "7": Plastics, Exterior Exposure:
 - 1. Use on the following items or areas:
 - a. Exterior exposed plastic enclosures where indicated
 - 2. Surface Preparation
 - a. Hand sand plastic surfaces to be coated with medium grit sandpaper to provide tooth for coating system
 - 3. Coating Material and Dry Film Thickness
 - a. Primer: Epoxy; 1 coat, 3.0 to 5.0 dry mils
 - b. Finish: Urethane; 1 coat, 3.0 to 5.0 dry mils

3.07 COLOR SCHEDULE

- A. Coat items per the following color schedule:

Service	Item	Color Name	Color Code
Potable Water	Piping and equipment	Moulton Blue	Tnemec B0821
	Public fire hydrants and bollards	Safety Yellow	Tnemec 02SF
	Private fire system	Safety Red	Tnemec 06SF
	Steel reservoir exterior	Desert Sand	Tnemec 04BR
Recycled Water	Piping and equipment	Moulton Magenta	Tnemec R0581

MOULTON NIGUEL WATER DISTRICT

Service	Item	Color Name	Color Code
Wastewater	Lift station piping and equipment	Moulton Tan	Tnemec S0356
		Moulton Brown	Tnemec D2161
	Treatment plant equipment	Desert Sand	Tnemec 04BR

- B. The color trade name is provided as a standard color only and does not indicate preference for a particular manufacturer. Match color based on physical paint sample.

3.08 FIELD QUALITY CONTROL

- A. Maintain an accurate written record of the coatings used each day.
 - 1. A copy of this record shall be furnished to the District at the close of each working day. This record shall list:
 - a. Coating manufacturer's product number
 - b. Amount of each coating in gallons used in the day and amount of excess mixed paint left over at the end of each day
 - c. Component ratio of mixed paints and any approved thinning procedures
- B. Notify the District prior to initial coat and after completion of each successive coat of paint to schedule inspection and checking of film thickness.
- C. Dry-Film Thickness Testing
 - 1. Measure thickness of each coat with a magnetic type dry-film thickness gage to verify compliance with specifications.
 - 2. Provide dry-film thickness gage as manufactured by Mikrotest, Elcometer, or equal.
 - 3. Do not measure within eight hours after application of the coating.
- D. Holiday Testing:
 - 1. Test the finish coat (except galvanizing) for holidays and discontinuities with an electrical holiday detector, low-voltage, wet-sponge type.
 - 2. Measuring equipment shall be provided by the Contractor. Provide detector as manufactured by Tinker and Razor, or equal.
- E. Non-Conforming Work:
 - 1. If the item has an improper finish color or insufficient film thickness as determined by the District, the surface shall be cleaned and topcoated with the specified paint material to obtain the specified color, coverage, and DFT.
 - 2. Visible areas of chipped, peeled, or abraded paint shall then be primed and finish coated in accordance with these specifications.

3.09 CLEANING

- A. During the progress of the Work, all discarded paint materials, rubbish, cans and rags shall be removed from the site at the end of each work day.
- B. Upon completion of painting work, all paint-spattered surfaces shall be cleaned. Spattered paint shall be removed by proper methods of washing and scraping, using care not to scratch or otherwise damage finished surfaces.
- C. At the completion of work of other trades, all damaged or defaced painted surfaces shall be touched-up and restored, as determined by the District.

END OF SECTION

SECTION 13110

DISSIMILAR METAL CONNECTIONS

PART 1 GENERAL

1.01 SECTION INCLUDES

- A. Insulating flange kits
- B. Dielectric unions
- C. Insulating bushings
- D. Casing seals and spacers
- E. Wax tape wrap system

1.02 REFERENCED STANDARDS

- A. American Water Works Association (AWWA)
 - 1. AWWA C210: Liquid-Epoxy Coating Systems for the Interior and Exterior of Steel Water Pipelines
 - 2. AWWA C213: Standard for Fusion-Bonded Epoxy Coating for the Interior and Exterior of Steel Water Pipelines
 - 3. AWWA C217: Wax Coating Systems for Underground Piping Systems
- B. NACE International
 - 1. NACE RP0286: Electrical Isolation of Cathodically Protected Pipelines
- C. NSF International
 - 1. NSF 61: Drinking Water Systems Components – Health Effects

1.03 SUBMITTALS

- A. Manufacturer's catalog cutsheets
- B. Test Results: The following test results shall be submitted to the District:
 - 1. Insulator test results for casing and insulating flange kits

PART 2 PRODUCTS

2.01 FLANGE INSULATION KITS

- A. Insulating flange kits shall contain full face gaskets, full length sleeves and double washers (steel and phenolic) on each end. Flange insulation kits shall consist of:
 - 1. Insulating Gaskets: Gaskets for flanges 16-inches or greater shall be Type E fullfaced Phenolic with Rectangular Nitrile or Viton O-Ring Seal. For flanges less than 16-inches, gaskets shall be Type E fullfaced neoprene faced phenolic.
 - 2. Insulating Stud Sleeves for Bolts: Insulating sleeves shall be 1/32 inch thick, G10 laminated glass tube. For installation on threaded studs use full length sleeves. For installation on threaded bolts, i.e., at butterfly valve flange bonnets and bases, the sleeves shall be half-length.
 - 3. Insulating Washers for Bolts: Insulating washers shall be 1/8-inch G10 laminated glass.
 - 4. Steel Washers Over Insulating Washer: 1/8-inch thick cadmium plated steel to be placed between the nut and the insulating washer.

2.02 DIELECTRIC UNIONS

- A. Union nut, two tailpieces, and a gasket that separates the tailpieces to prevent an electric current from occurring
- B. Threaded or soldered connections
- C. Forged construction, Class 3000 Service

2.03 INSULATING BUSHINGS

- A. Design:
 - 1. Isolate dissimilar metals
 - 2. Designed for heavy hex wrenching
- B. Material: Nylon

2.04 CASINGS

- A. Casing seals:
 - 1. Designed to prevent moisture intrusion into the casing annular space shall be either a rubber link or pull-on sleeve type.
 - a. Rubber link casing seals are made of molded, solid, synthetic rubber and are connected together by corrosion resistant bolts and nuts. After the links are placed in the casing opening, the bolts are turned to create an airtight and watertight seal.
 - b. Sleeve casing seals are made of 1/8-inch thick, synthetic rubber. The sleeve is fastened to the exterior of the casing and carrier pipe using stainless steel strapping.

- B. Casing Spacers: Casing insulators used to prevent contact between the casing and carrier pipe shall be comprised of a fusion coated, 8-inch wide steel band with 2-inch wide glass reinforced plastic runners.

2.05 WAX TAPE COATING SYSTEM

- A. General: Conform to requirements of AWWA C217.
- B. Primer: Blend of petrolatum or petroleum wax that may contain suitable inhibitor. Primer shall be supplied by tape manufacturer and shall protect metal surfaces and promote adhesion.
- C. Wax Tape: Wrap primed surfaces with a synthetic fabric tape saturated with a blend of petrolatum, plasticizers, and corrosion inhibitors that is easily formable over irregular surfaces. A compatible petrolatum filler should be used to smooth over irregular surfaces.
- D. Outer Covering: The primed and wax tape wrapped flange shall be wrapped with a plastic tape covering consisting of three (3) layers of 1.5 mil, polyvinylidene chloride or PVC, high cling membranes wound together as a single sheet.

PART 3 EXECUTION

3.01 FLANGE INSULATION KITS

- A. Insulating kits shall be installed to isolate any flanged dissimilar metal pipes.
- B. Moisture, soil, or other foreign matter must be carefully prevented from contacting any portion of the mating surfaces prior to installing insulator gasket. If moisture, soil or other foreign matter contacts any portion of these surfaces, the entire joint shall be disassembled, cleaned with a suitable solvent and dried prior to reassembly. Care shall be taken to prevent any excessive bending or flexing of the gasket.
- C. Alignment pins shall be used to properly align the flange and gasket.
- D. The manufacturer's recommended bolt-tightening sequence shall be followed. Bolt insulating sleeves shall be centered within the insulation washers so that the insulating sleeve is not compressed and damaged.
- E. Neither aluminum, graphite, nor any other electronically conductive pigment shall be used in paints or coatings on the flanges, bolts, or washers of any insulating device.

3.02 DIELECTRIC UNIONS

- A. Install dielectric unions on all threaded or soldered dissimilar metal pipes.
- B. Moisture, soil, or other foreign matter must be carefully prevented from contacting any portion of the mating surfaces prior to installing insulator gasket. If moisture, soil or other foreign matter contacts any portion of these surfaces, the entire joint shall be disassembled, cleaned with a suitable solvent and dried prior to reassembly.

3.03 CASINGS

- A. The casing end seal shall be installed wherever a metallic pipeline passes through a steel casing in order to restrict water intrusion into the casing annular space. The casing seal shall be installed according to the manufacturer's recommendations.
- B. The encased sections of metallic piping shall be electrically isolated from the casing. Use casing insulators to prevent metallic contact and ensure a minimum amount of standoff between casing and carrier pipe. Distance between spacers shall be small enough to prevent excessive sagging of the line.

3.04 COATINGS FOR CONCRETE-ENCASED METALLIC PIPE

- A. Provide dielectric coating on all metallic pipes, wall sleeves, and conduits encased in cast-in-place concrete structures to prevent pipe contact with the concrete and/or reinforcing steel.
- B. Dielectric coating shall be epoxy material conforming to NSF 61 and AWWA C210 or AWWA C213.

3.05 WAX TAPE WRAP

- A. Install wax tape coating system on all buried insulating flange kits and all joints, valves, and coupling with joint bonding per the requirements of AWWA C217. Where discrepancies exist between current AWWA C217 and this specification, the more stringent requirements shall govern.
- B. Install wax tape tight and without air pockets. Apply three neat and tight outer layers over the flange, valve, or coupling. Individually wrap each bolt or tie-rod.
- C. The edges of flanges 18-inches in diameter and larger shall be wrapped with an additional layer of 10-mil pipe tape (two layers, 50-percent overlap) to protect wax tape during backfilling process.

3.06 FIELD QUALITY CONTROL

- A. Notification for Testing: The Contractor shall notify the District at least five days in advance of testing.
- B. Insulating Flange Kits: Retain certified NACE Cathodic Protection Tester to test and confirm isolation.
 - 1. Method:
 - a. Buried insulators must be tested and accepted by the District's Corrosion Engineer prior to application of wax tape and backfilling.
 - b. The assembled flange shall be tested with a Gas Electronics Model 601 Insulator Checker or equivalent instrument that is specifically designed for the testing of insulating flanges.
 - c. The testing shall be done in accordance with NACE RP0286-97.

MOULTON NIGUEL WATER DISTRICT

- d. If a short is indicated, each bolt shall be tested to verify the integrity of each insulating sleeve before the flange is disassembled. The Contractor shall find any and all shorts or shorted bolts.
 - 2. Acceptance: The installation of the insulating flange kit shall be considered complete when the testing instrument indicates that no shorts or partial shorts are present. Any deflection of the meter, no matter how small, indicates a short. All disassembly and re-assembly necessary for acceptance shall be done at no additional cost to the District.
- C. Casing Isolation: Retain certified NACE Cathodic Protection Tester to test all casings to verify that they are metallicity isolated from the pipe.
- 1. Method:
 - a. The casing shall be considered fully isolated if the difference between the structure-to-soil potential of the casing and the pipe is more than 30 millivolts.
 - b. If this potential difference is less than 30 millivolts the casing and the pipe may still be adequately isolated. In this case the Corrosion Engineer shall submit a test approach and test data to verify isolation.
 - 2. Acceptance: A potential difference of 30 millivolts or greater or the District's acceptance of the Corrosion Engineer's test report.

END OF SECTION

SECTION 13121

CORROSION PROTECTION

PART 1 GENERAL

1.01 SECTION INCLUDES

- A. Zinc Anodes
- B. Wire and Cable
- C. Alumino-Thermic Weld Primer and Caps

1.02 RELATED REQUIREMENTS

- A. Section 02223, Trenching, Backfilling, and Compacting
- B. Section 09900, Painting and Coating
- C. Section 13110, Dissimilar Metal Connections

1.03 REFERENCED STANDARDS

- A. ASTM International (ASTM)
 - 1. ASTM B3: Standard Specification for Soft or Annealed Copper Wire
 - 2. ASTM B8: Standard Specification for Concentric-Lay-Stranded Copper Conductors, Hard, Medium-Hard, or Soft
 - 3. ASTM B418: Standard Specification for Cast and Wrought Galvanic Zinc Anodes
 - 4. ASTM D1248: Standard Specification for Polyethylene Plastics Extrusion Materials for Wire and Cable
 - 5. ASTM D2220: Standard Specification for Poly (Vinyl Chloride) Insulation for Wire and Cable, 75°C Operation
- B. Underwriters Laboratory
 - 1. UL 83: Thermoplastic Insulated Wires and Cables

1.04 SUBMITTALS

- A. Manufacturer's catalog cutsheets
- B. As-built Drawings: The Contractor shall maintain as-built drawings showing the exact locations of all corrosion monitoring test stations, insulators, and wire trenching runs. Location changes from the design drawings shall be legibly indicated in red on a blue line copy of the design drawings. These drawings shall be submitted to the District before the work is considered complete.

- C. Test Results: The following test results shall be submitted to the District:
 - 1. Continuity test report
 - 2. Insulator test results
 - 3. Anode and pipe lead wire integrity tests results

PART 2 PRODUCTS

2.01 ZINC ANODES FOR NEW SERVICES AND AIR-VACS

- A. Zinc Anode: Anode shall conform to ASTM B 418, Type II and shall be a prepackaged zinc alloy ingot having a chemical composition not exceeding the following limits:
 - 1. Aluminum: 0.005-percent Max.
 - 2. Cadmium: 0.003-percent Max.
 - 3. Iron: 0.0014-percent Max.
 - 4. Zinc: Remainder
- B. Ingot Weight: 12 pounds
- C. Anode Backfill: Each zinc anode shall be prepackaged in a permeable cloth bag with a backfill of the following composition or installed bare and backfilled with material having the following composition:
 - 1. Gypsum: 75-percent
 - 2. Powdered Bentonite: 20-percent
 - 3. Anhydrous Sodium Sulfate: 5-percent
- D. Backfill grains: Capable of 100-percent passing through a 100 mesh screen. The backfill shall be firmly packed around the anode by mechanical vibration to density which will maintain the zinc ingot in the center of the cloth bag and surrounded by at least 1-inch of backfill.
- E. Steel Core: Anode shall be cast full length with an electrogalvanized 1/4-inch diameter steel core which shall be exposed at one end for connection of the anode lead wire.
- F. Anode Lead Wire: Wire shall be attached to the steel core with silver solder by the manufacturer. The connection shall be encapsulated in a heat-shrinkable sleeve. Anode lead wire shall be of sufficient length to extend from the anode to the designated termination point without a splice. Wires with cut or damaged insulation will not be accepted and replacement of the entire lead will be required at the Contractor's expense.

2.02 WIRE AND CABLE

- A. Material: Copper conforming to ASTM Standards B3 or B8
- B. Insulation: All DC wires shall be stranded copper with high molecular weight polyethylene (HMWPE) or thermal plastic (THWN) insulation suitable for direct burial in corrosive soil and water, conforming to UL 83 and ASTM Standards B3 or B8.

1. HMWPE insulation and shall conform to the requirements of ASTM D1248 Type 1, Class C.
2. THWN insulation shall conform to the requirements of ASTM D2220.

2.03 ALUMINO-THERMIC PRIMER AND CAPS

- A. Weld Cap Primer: Weld cap primer shall be an elastomer-resin based corrosion resistant primer for underground services.
- B. Weld Caps: Alumino-thermic welds shall be sealed with a pre-fabricated plastic cap filled with bituminous mastic compound on a base of elastomeric tape or a polymer-coated synthetic fabric with a synthetic adhesive
- C. Sizing: Weld charge size, alloy, and mold size shall be as specified by the manufacturer of the weld kit for use on steel or ductile iron pipe.

PART 3 EXECUTION

3.01 ZINC ANODES

- A. General: Where called for on the drawings, prepackaged zinc anodes shall be installed in excavated, drilled, or punched holes a minimum of 8-inches in diameter. Anodes shall be installed below the level of the service or air/vac line, with a minimum separation of 2 feet between the copper water tubing and the zinc anode maintained at all times. Anodes shall not be lowered, transported, handled, or lifted by the lead wire.
- B. Location: Anode shall be installed approximately midway between pipeline and meter box.
- C. Backfilling: After the prepackaged anode is placed in the hole, approximately 5 gallons of water shall be poured into the hole so that the anode is completely covered with water. Allow water to soak for 30 minutes. Stone-free native soil shall then be used to backfill the anode hole. Imported sand shall not be used for backfilling. The anode hole shall be backfilled in stages and carefully compacted to ensure that no voids exist around the bag and that the bag and anode wire are not damaged. After backfill is level with the top of the anode, another 5 gallons of water shall be poured into the hole to completely saturate the soil backfill. More water shall be added if it is suspected that the backfill is not completely saturated. Care shall be taken to avoid damage to the anode and anode lead wires.
- D. Anode Lead Wire: The anode lead wire shall extend from the anode along the copper pipe to the water service or air/vac meter box. The anode lead wire shall be attached to the copper water service or air/vac riser inside the meter box using a bronze mechanical grounding clamp.

3.02 BOND WIRE

- A. Wire Quantity and Arrangement:
 1. Two or three bond wires shall be installed on ductile iron and steel pipe across each buried, unwelded pipe joint or mechanical joint including valves, couplings, special fittings, and flanges except insulating flange.

2. Bond wires shall not be attached to valve bodies, but instead to the flange of the valve.
3. Bond wires shall have minimal slack wire at each weld but otherwise be as short as possible.

B. Connection to Pipe:

1. Preparation of Wire: Use a cutter to prevent deforming wire ends. Remove only enough insulation from the wire to allow the weld connection to be made. Do not use a hacksaw for cutting.
2. Preparation of Metal:
 - a. Remove all coating, dirt, grime and grease from the metal pipe at weld location by wire brushing and/or use of suitable safe solvents. Clean the pipe to a bright, shiny surface free of all serious pits and flaws by use of mechanical grinder or a file.
 - b. The area of the pipe where the attachment is to be made must be absolutely dry. Failure to provide a dry surface for welding will result in a poor quality weld and could result in serious injury to the workman.
3. Alumino-Thermic Weld Wire to Pipe:
 - a. The attachment of copper wire shall be made using an alumino-thermic weld.
 - b. The wire is to be held at a 30-degree to 45-degree angle to the surface when welding.
 - c. Manufacturer's recommended cartridge size and type shall be used.
 - d. Only one wire shall be connected with each weld.
4. Coating of All Completed Welds:
 - a. Thoroughly clean by wire brushing the area to be coated.
 - b. The area must be completely dry.
 - c. Overcoat the weld cap with a bituminous mastic coating per Section 09900 in accordance with the manufacturer's recommendations.
 - d. Completely coat the weld, all bare pipe surfaces around the weld and any exposed copper wire.
 - 1) For non-mortar coated pipe, extend coating 3 inches beyond weld cap.
 - 2) For mortar coated pipe, apply coating up to but not over mortar.
 - a) Allow sufficient time to dry prior to repair of the mortar coating on steel pipe.
 - b) The mortar coating shall be repaired after the bituminous weld coating has dried, using fast setting, non-shrinkable mortar to restore the original outside diameter of the pipe at each weld location.

3.03 FIELD QUALITY CONTROL

- A. Notification for Testing: The Contractor shall notify the District at least five days in advance of testing.
- B. Bond Wire Welds: Inspect all wire insulation for damage and test all bond wire welds.
 1. Test Method:

- a. All wire insulation shall be visually inspected. As soon as the weld has cooled, all completed wire connection welds shall be tested, in the presence of the District, for strength by striking the weld with a sharp blow with a 2-pound hammer while pulling firmly on the wire.
 - b. Welds failing this test shall be re-welded and re-tested.
- C. Pipeline Continuity Through Bonded Or Mechanical Joints: Retain certified NACE Cathodic Protection Tester to test all sections that contain bonded joints, valves, and couplings.
- 1. Method:
 - a. Continuity is verified when the measured linear resistance of section of pipe being tested is approximately equal its theoretical value.
 - b. Resistance shall be measured by the linear resistance method.
 - 1) A direct current shall be impressed from one end of the test section to the other (test station to test station) using a DC power supply (battery).
 - 2) A voltage drop is measured through the test section at several current levels. The resistance (R) is calculated using the equation $R = dV/I$, where dV is the voltage drop and I is the current.
 - 3) The resistance shall be calculated for three or four different current levels.
 - 2. Acceptance:
 - a. Acceptance is reasonable comparison of the measured resistance with the calculated or theoretical resistance.
 - b. The measured resistance shall not exceed the theoretical resistance by more than 130-percent. The theoretical resistance is the sum of the pipe resistance and the bond (wire or clip) resistance.
- D. Anode and Pipe Lead Wire Integrity Tests: Retain certified NACE Cathodic Protection Tester to test all anodes.
- 1. Method: After the pipe and anodes and lead wire trenches are backfilled, each anode lead wire shall be tested for electrical continuity to the anode by measuring the anode's potential with respect to a copper-copper sulfate reference electrode.
 - 2. Acceptance: The measured open circuit potential of the anode shall be a minimum of 1.0 volts, or as specified by the manufacturer and accepted by the District.

END OF SECTION

SECTION 15000

PIPE SUPPORTS

PART 1 GENERAL

1.01 SECTION INCLUDES

- A. Pipe hangers
- B. Pipe supports

1.02 RELATED REQUIREMENTS

- A. Section 09900, Painting and Coating

1.03 REFERENCED STANDARDS

- A. ANSI B31.1.0: Pressure Piping
- B. Manufacturers Standardization Society (MSS) Standard Practice: Pipe Hangers and Supports
 - 1. SP-58: Materials, Design, Manufacture, Selection, Application, and Installation
 - 2. SP-69: Selection and Application
 - 3. SP-89: Fabrication and Installation Practices

1.04 SUBMITTALS

- A. Product data sheets

1.05 GENERAL

- A. Contractor is responsible for furnishing pipe supports for all above grade piping, whether or not the supports are shown on the Drawings. It is the responsibility of the Contractor to adequately space and size the supports. Supports shall be of sufficient design and spacing to withstand all static, dynamic, and seismic loads, with the appropriate safety factor. Where supports are not shown on the Drawings, Contractor shall provide stainless steel or carbon steel supports painted in accordance with Division 9. Maximum allowable spacing for pipe supports is ten feet. Maximum allowable spacing for certain types of pipe is less than ten feet where shown or specified. Contractor shall ensure that supports, anchor bolts, and bolt embedment are suitable for design loads with a minimum safety factor of 3. All pipes, whether horizontal, or vertical, shall be supported to prevent lateral sway and visible deflection.
- B. All pipe and appurtenances connected to equipment shall be supported in such a manner as to prevent any strain being imposed on the equipment.

MOULTON NIGUEL WATER DISTRICT

- C. All pipe and tubing shall be supported as required to prevent significant stresses in the pipe or tubing material, valves, and fittings and to support and secure the pipe in the intended position and alignment. All supports shall be designed to adequately secure the pipe against excessive dislocation due to thermal expansion and contraction, internal flow forces, and all probable external forces such as equipment, pipe, and personnel contact. All pipe supports shall be submitted for review prior to installation.
- D. Hangers and supports shall be spaced in accordance with ANSI B31.1.0, unless noted otherwise on the Contract Drawings, or specified herein.
- E. Metal piping shall be supported at intervals of not more than 10'0" with a minimum of one support per pipe section at pipe fittings, valves and flowmeters. There shall be no noticeable sagging of piping between supports.
- F. Piping shall be rigidly anchored to walls and ceilings by means of suitable pipe hangers or wall brackets. Concrete inserts shall be used for the support of piping hangers wherever practicable. Where it is necessary to install hangers or supports after the concrete has been poured or other masonry work is finished, 316 stainless steel bolts in concrete anchors shall be used unless noted otherwise on the Contract Drawings. Unless otherwise shown or specified, hangers shall be of adjustable split-ring swivel type, Grinnell Figure 104, or equal. Strap hangers will not be acceptable.
- G. All miscellaneous piping, including valves and devices therein, shall be supported approximately 1-1/2 inches from walls and ceilings on suitable brackets.
- H. All uninsulated PVC or fiberglass piping shall be protected from local stress concentrations at each support point. Protection shall be provided by 316 stainless steel protection shields or other method as approved by the District's Representative. Where pipes are bottom supported 180 degrees, arc shields shall be furnished. Where 360 degrees of support is required, such as U bolts, protection shields shall be provided for the entire pipe circumference. Protection shield have an 18 gauge minimum thickness, not to be less than 12 inches in length and be securely fastened to pipe with stainless steel metal straps not less than 1/2 inch wide.
- I. Any required pipe supports for which the supports specified in this Section are not applicable shall be fabricated or constructed, as part of the work of this section, from standard structural steel shapes, concrete, and anchor hardware similar to items previously specified herein and shall be subject to the approval of the Engineer and District.
- J. Expansion bolts shall be equal to Kwik-Bolt as manufactured by the Hilti or Wej-it manufactured by Wej-it Fastening systems. Unless shown otherwise all expansion bolts shall be of Type 316 stainless steel and shall be double expansion shields. Unless otherwise directed by the District's Representative, the length of expansion bolts shall be sufficient to place the wedge portion of the bolts a minimum of 1-inch behind the steel reinforcement.
- K. All supports and hangers shall be crated, delivered and uncrated so as to protect against any damage.
- L. All parts shall be properly protected so that no damage or deterioration shall occur during a prolonged delay from the time of shipment until installation is completed.

- M. Finished iron or steel surfaces not galvanized or painted shall be properly protected to prevent rust and corrosion.
- N. Unless otherwise specified herein, pipe hangers and supports shall be as manufactured by Grinnell Co.

PART 2 PRODUCTS

2.01 DESIGN

- A. All supports and parts shall conform to the latest requirements of the ANSI Code for Pressure Piping B31.1.0, and MSS Standard Practice SP-58, SP-69 and SP-89, and shall be sized for a Site Class D Seismic area, except as supplemented or modified by the requirements of this specification.
- B. "C" type beam clamps will not be allowed.
- C. Designs generally accepted as exemplifying good engineering practice, using stock or production parts, shall be utilized wherever possible.
- D. All pipes, horizontal and vertical, requiring rigid support shall be supported by the Contractor by methods as described herein. Supports shall be provided at changes in direction and elsewhere as shown on the Drawings or specified herein.
- E. No piping shall be supported from metal stairs, ladders and walkways unless specifically directed or authorized by the District's Representative.
- F. All pipe supports shall have liberal strength and stiffness to support the respective pipes under the maximum combination of peak loading conditions, to include pipe weight, liquid weight, liquid movement, and pressure forces, thermal expansion and contraction, vibrations, and all probable externally applied forces.
- G. Accurate weight balance calculations shall be made by the Contractor to determine the required supporting force at each hanger location and the pipe weight load at each equipment connection.
- H. Pipe hangers shall be capable of supporting the pipe in all conditions of operation. They shall allow free expansion and contraction of the piping, and prevent excessive stress resulting from transferred weight being induced into the pipe or connected equipment.
- I. All rigid hangers shall provide a means of vertical adjustment after erection.
- J. Where the piping system is subject to shock loads, such as seismic disturbances or thrusts imposed by the actuation of safety valves, hanger design shall include provision of shock absorbing devices of the approved design. This requirement applies to all locations where relief valves are employed.
- K. If vibration is encountered after the piping system is in operation, appropriate vibration control equipment will be installed at the direction of the Engineer at no additional cost to the District.
- L. Hanger rods shall be subject to tensile loading only. At hanger locations where lateral or axial movement is anticipated, suitable linkage shall be provided to permit swing.

- M. Where horizontal piping movements are greater than 1/2 inch, or where the hanger rod angularity from the vertical is greater than 4 degrees from the cold to hot position of the pipe, the hanger pipe and structural attachments shall be offset in such manner that the rod is vertical in the hot position.
- N. Hangers shall be designed so that they cannot become disengaged by movements of the supported pipe.
- O. Metallic piping 2-1/2 inches or larger diameter shall be supported at a maximum spacing of 10 feet with a minimum of one support per pipe section at pipe fittings, valves and flow meters unless shown otherwise on the Drawings.
- P. Support spacing for metallic piping 2-inch diameter and smaller and copper tubing shall not exceed 5 feet unless shown otherwise on the Drawings.
- Q. All vertical pipes shall be supported at each floor or at intervals of not more than 10 feet by approved pipe collars, clamps, brackets, or wall rests, and at all points necessary to ensure rigid construction.
- R. Supports shall be provided at changes in direction and elsewhere as shown in the Drawings or specified herein. No piping shall be supported from other piping or from metal stairs, ladders, and walkways, unless specifically directed or authorized by the District's Representative.
- S. Contractor shall provide suitable method of support for pipes connecting to plastic storage tanks. Where supports connect directly to tanks, Contractor shall ensure that tanks are supplied with molded lugs or connection points, where required.

PART 3 EXECUTION

3.01 INSTALLATION

- A. All pipes, horizontal and vertical, shall be rigidly supported from the building structure by approved supports. Supports shall be provided at changes in direction and elsewhere as shown on the Drawings or specified herein. No piping shall be supported from other piping or from metal stairs, ladders, and walkways, unless specifically directed or authorized by the District's Representative.
- B. Pipe supports shall be provided to minimize lateral forces through valves, both sides of split type couplings, and sleeve type couplings and to minimize all pipe forces on pump housings. Pump housings shall not be utilized to support connecting pipes.
- C. All vertical pipes shall be supported at each floor or at intervals of at least 10 ft. by approved pipe collars, clamps, brackets, or wall rests, and at all points necessary to ensure rigid construction.
- D. Pipe supports shall not result in point loadings but shall distribute pipe loads evenly along the pipe circumference.
- E. Effects of thermal expansion and contraction of the pipe shall be accounted for in pipe support selection and installation.

MOULTON NIGUEL WATER DISTRICT

- F. Inserts for pipe hangers and supports shall be installed on existing concrete walls and ceilings. Before setting these items, all Drawings and figures which have a direct bearing on the pipe location shall be checked.
- G. Continuous metal inserts shall be embedded flush with the concrete surface.

END OF SECTION

SECTION 15041

CHLORINATION OF POTABLE WATER MAINS AND SERVICES FOR DISINFECTION

PART 1 GENERAL

1.01 SECTION INCLUDES

- A. Disinfection by chlorination of potable water mains, services, appurtenances, and connections by the following methods:
 - 1. Liquid chlorine solution
 - 2. Sodium hypochlorite

1.02 RELATED REQUIREMENTS

- A. Section 15042, Hydrostatic Testing of Pressure Pipelines

1.03 DEFINITIONS

- A. Liquid chlorine solution: The commercially available form of liquefied elemental chlorine gas (Cl_2)
- B. Sodium hypochlorite: Clear light-yellow liquid solution, typically 12.5-percent concentration, of sodium hypochlorite (NaOCl)

1.04 REFERENCED STANDARDS

- A. American Water Works Association:
 - 1. AWWA B300: Hypochlorites
 - 2. AWWA B301: Liquid Chlorine
 - 3. AWWA C651: Disinfecting Water Mains

1.05 SEQUENCING

- A. Concurrent Testing: Disinfecting the mains and appurtenances, hydrostatic testing, and preliminary retention may run concurrently for the required 24-hour period.
- B. In the event there is leakage, and repairs are necessary, additional disinfection shall be required.

1.06 SUBMITTALS

- A. Action Submittals:
 - 1. Testing plan and schedule
 - 2. Disinfection products
 - 3. Testing equipment
- B. Certified testing results

1.07 QUALITY ASSURANCE

- A. Conform to AWWA C651. Where discrepancies exist between current AWWA C651 and this specification, the more stringent requirements shall govern.

PART 2 PRODUCTS

2.01 LIQUID CHLORINE SOLUTION

- A. Liquid chlorine solution shall be in accordance with the requirements of ANSI/AWWA B301.

2.02 SODIUM HYPOCHLORITE

- A. Sodium hypochlorite shall be in accordance with the requirements of ANSI/AWWA B300.

PART 3 EXECUTION

3.01 DISINFECTION PROCEDURES

- A. General Requirements
 - 1. Chlorinate all water mains, water services, attached appurtenances, connections, and other water facilities before being placed in service or connected to existing facilities.
 - 2. The Contractor shall notify the District two (2) working days prior to chlorination of facilities.
 - 3. All required corporation stops and other plumbing materials necessary for chlorination or flushing of the main shall be installed by and at the expense of the Contractor.
 - 4. All mains shall be thoroughly flushed prior to disinfection.
 - 5. Every service connection served by a main being disinfected shall be tightly shutoff at the curb stop before filling the main for disinfection. Care shall be taken to expel all air from the main and services during the filling operation.

6. Methods of chlorination that may be used are:
 - a. Continuous-feed Method
 - 1) Treated water shall be retained in the system for a minimum of 24 hours and shall contain an initial chlorine concentration of 25 ppm and a chlorine residual of not less than 10 ppm at the end of the retention period in all sections being disinfected.
 - b. Slug Method
 - 1) Water shall be fed slowly into the pipeline with chlorine applied in amounts to produce an initial dosage of not less than 100 ppm.
 - 2) Chlorine shall be applied continuously to develop a solid column, or “slug”.
 - 3) All interior surfaces shall be exposed to a concentration of approximately 100 ppm for at least 3 hours.
 - 4) If concentration drops below 50 ppm at any time, flow shall be stopped; chlorination equipment shall be relocated at the head of the slug and, as flow resumes, chlorine shall be applied to restore the free chlorine in the slug to not less than 100 ppm.
- B. Liquid Chlorine Solution Dosing Requirements
 1. Liquid chlorine solution shall be injected with a solution feed chlorinator and a water booster pump.
- C. Sodium Hypochlorite Dosing Requirements
 1. Sodium hypochlorite should be diluted in water to desired concentration and pumped into the pipeline at a measured rate.

3.02 BACTERIOLOGICAL TESTING

- A. The Contractor is responsible for bacteriological testing.
- B. Provide a clean and disinfected sample port including all necessary appurtenances for the purposes of obtaining the sample.
- C. Bacteriological testing shall be conducted after disinfection and final flushing, and when typical system chlorine residuals are present.
 1. The new main shall be allowed to sit for a minimum of 16 hours without any water use. After the 16 hours, two consecutive acceptable samples from each location shall be collected at a minimum of 15 minutes apart. The sampling tap shall be left running between the sample collections.
 2. The main shall not be flushed again prior to samples being taken.
 3. The number and location of required samples shall be determined by the District.
 4. The samples shall be delivered to an EPA-certified, independent laboratory within six hours.
 5. An EPA-approved bacteriological quality test shall be performed by the laboratory. Certified test results with chain of custody shall be delivered to the District.

- D. All mains must successfully pass bacteriological tests prior to connecting to the existing system.
 - 1. Results of satisfactory test shall demonstrate the absence of coliform organisms and a plate count of less than 500 CFU/mL from each sample location.
 - 2. If the tests are not satisfactory, the Contractor shall provide additional disinfection as required.
 - 3. Retesting of the system may be required if 90 days or more have passed between the date of testing and acceptance by the District.
- E. The District reserves the right to perform their own sample collection and testing to validate any test results, as they see necessary. The District-obtained test results shall govern the determination of pipeline acceptability.

3.03 FLUSHING

- A. After chlorination, the water shall be flushed from the line, at its extremities until the replacement water tests are equal chemically and bacteriologically to those of the permanent source of supply.
- B. The chlorinated water may be used later for testing other lines, or if not so used, shall be disposed of by the Contractor. This flushing water shall be discharged to a sanitary sewer. Discharge to the storm drain or watercourse requires acceptance by the District.
- C. The Contractor shall be responsible for all costs to dechlorinate the water before it enters any storm drain or watercourse. The District will not be responsible for loss or damage resulting from such disposal.

3.04 CUTTING INTO EXISTING MAINS

- A. Following the opening of an existing potable water main, the interior of all accessible pipes and fittings shall be swabbed with a 1-percent hypochlorite solution. The drained portion of the existing line and any new section shall be flushed from two directions toward the cut-in, if possible.

END OF SECTION

SECTION 15042

HYDROSTATIC TESTING OF PRESSURE PIPELINES

PART 1 GENERAL

1.01 SECTION INCLUDES

- A. Hydrostatic leakage testing of new or rehabilitated pressure pipelines

1.02 RELATED REQUIREMENTS

- A. Section 02223, Trenching, Backfilling, and Compacting
- B. Section 15041, Chlorination of Potable Water Mains and Services for Disinfection

1.03 DEFINITIONS

- A. Working Pressure: Maximum anticipated sustained operating pressure

1.04 REFERENCE STANDARDS

- A. American Water Works Association (AWWA)
 - 1. AWWA C600: Installation of Ductile Iron Water Mains and Their Appurtenances
 - 2. AWWA C604: Installation of Buried Steel Water Pipe - 4 In. (100 mm) and Larger
 - 3. AWWA C605: Underground Installation of Polyvinyl Chloride (PVC) and Molecularly Oriented Polyvinyl Chloride (PVCO) Pressure Pipe and Fittings

1.05 SEQUENCING

- A. Requirements Prior to Testing:
 - 1. Before testing, the pipe trench shall be backfilled and compacted to the ground surface per Section 02223.
 - 2. All concrete anchor blocks shall be allowed to cure a sufficient time to develop a minimum strength of 2,000 psi, but not less than five (5) days, before testing, unless otherwise directed by the District.
 - 3. Steel pipelines shall not be tested before the mPortar lining and coating on all of the pipe lengths in the line have attained an age of 14 days. Cement-mortar lined pipe shall not be filled with water until a minimum period of eight hours has elapsed after the last joint in any section has been made.
 - 4. All surrounding utilities shall be installed prior to testing.
- B. Connection to Existing Mains: Complete hydrostatic testing before connecting new pipelines with existing pipelines.

- C. Final Pavement: All pipeline shall be satisfactorily pressure tested prior to the placement of final pavement.
- D. Disinfection: Disinfecting of pipelines may occur concurrently with hydrostatic testing.

1.06 SUBMITTALS

- A. Action Submittals:
 - 1. Testing plan and schedule
 - 2. Testing equipment, pumps, gauges, and meters
 - 3. Meter and gauge calibration certification
- B. Certified testing results

1.07 QUALITY ASSURANCE

- A. Conform to requirements of the following standards depending on the pipeline material. Where discrepancies exist between the current AWWA standards and this specification, the more stringent requirements shall govern.
 - 1. Ductile iron pipe: AWWA C600
 - 2. Steel pipe: AWWA C604
 - 3. PVC pipe: AWWA C605
- B. Testing Company
 - 1. All testing shall be performed by a District-approved testing company.
 - 2. Tester will have a gauge and meter, calibrated annually.

PART 2 PRODUCTS

2.01 WATER

- A. The same water used for chlorination of the pipeline may be used to fill the line for pressure testing.
- B. Make up water for testing shall be potable water.

PART 3 EXECUTION

3.01 TEST PROCEDURES

- A. Fill pipeline test section with water while purging all air.
- B. For cement mortar lined pipe, allow water to stand for at least 24 hours to permit maximum absorption of water by the lining. Additional makeup water shall be added to replace water absorbed by the lining.

- C. Apply test pressure by approved pumping assembly connected to pipe with temporary test bulkheads.
- D. Monitor leakage rate for duration of test by measuring the required makeup water flow rate to maintain test pressure within allowable variance.

3.02 TEST PRESSURES

- A. Test pressures for pressurized pipelines shall be the greater of the following:
 - 1. 225 psi
 - 2. 50 psi in excess of working pressure
 - 3. As required to ensure pressure at highest elevation of the test section is at least 1.5 times the working pressure
- B. Hydrostatic test pressures at any point in the section tested shall not exceed the following:
 - 1. Design pressure capacity of pipe and appurtenances
 - 2. Design capacity of thrust restraints
- C. Ensure the test pressure variance is less than +/- 5 psi for duration of test.

3.03 TEST DURATION

- A. Perform hydrostatic leakage test for a minimum duration of four hours.

3.04 PIPELINE FILLING

- A. Filling velocity: The pipeline should be filled at a rate such that the average velocity of flow is less than 1-foot per second. At no time shall the maximum velocity of flow exceed 2-feet per second. For convenience, the following table has been provided to relate the velocity of 1-foot per second to an equivalent volume flow rate.

Normal Pipe Diameter (inches)	Flow Rate (gallons per minute)
4	38
6	88
8	158
12	353
16	624

- B. Air Removal:
 - 1. All air should be purged from the pipeline before checking for leaks or performing pressure or acceptance tests on the system.
 - 2. To accomplish this, if air valves or hydrants or other outlets are not available, corporation cocks shall be installed at the high points to expel the air, and these cocks shall be tightly closed afterwards. If allowed by the District, air may be purged using temporary blow-offs at the end of the lines at the test bulkhead.

3.05 ALLOWABLE LEAKAGE RATES

A. Ductile Iron Pipe:

$$L = (S \times D \times P^{1/2}) / (133,200)$$

Where:

L = Allowable leakage rate (makeup water flow rate), in gallons per hour

S = Length of pipe tested, in feet

D = Nominal diameter of pipe, in inches

P = Average test pressure during hydrostatic test, in gauge pound per square inch (psig)

B. Steel and PVC Pipe:

$$L = (N \times D \times P^{1/2}) / (7,400)$$

Where:

L = Allowable leakage rate (makeup water flow rate), in gallons per hour

N = Number of joints (not including welded joints) in pipeline tested, in feet

D = Nominal diameter of pipe, in inches

P = Average test pressure during hydrostatic test, in gauge pound per square inch (psig)

C. Flanged, grooved, and welded joints shall have zero leakage.

3.06 REPAIR

A. Any noticeable leak shall be stopped and all defective pipe, fittings, valves, and other accessories discovered in consequence of the test shall be removed and replaced by the Contractor with sound material.

B. Repeat test until the pipeline meets the testing requirements.

END OF SECTION

SECTION 15043

TESTING OF NON-PRESSURE SEWER PIPELINES AND MANHOLES

PART 1 GENERAL

1.01 SECTION INCLUDES

- A. Low-pressure air test of sewer pipelines
- B. Infiltration testing of sewer pipelines
- C. Deflection testing of sewer pipelines
- D. Leakage testing of manholes

1.02 RELATED REQUIREMENTS

- A. Section 03461, Precast Reinforced Concrete Manholes
- B. Section 15066, Gravity Sewer Pipelines
- C. Section 15068, Sewer Laterals

1.03 REFERENCED STANDARDS

- A. ASTM International:
 - 1. ASTM C828: Standard Test Method for Low-Pressure Air Test of Vitrified Clay Pipe Lines
 - 2. ASTM C1244: Standard Test Method for Concrete Sewer Manholes by the Negative Air Pressure (Vacuum) Test Prior to Backfill
 - 3. ASTM F1417: Standard Practice for Installation Acceptance of Plastic Non-pressure Sewer Lines Using Low-Pressure Air

1.04 QUALITY ASSURANCE

- A. Conform to requirements of the following standards depending on the pipeline material. Where discrepancies exist between the current standards and this specification, the more stringent requirements shall govern.
 - 1. Vitrified Clay Pipe: ASTM C828
 - 2. PVC Pipe: ASTM F1417

PART 2 PRODUCTS (NOT USED)

PART 3 EXECUTION

3.01 GENERAL

- A. General:
 - 1. The Contractor shall furnish all equipment and materials required for testing.
 - 2. All tests shall be made in the presence of the District. No one shall be allowed in the manholes during testing because of the hazards present.
- B. Leakage: Each section of sewer between two successive manholes shall be tested for leakage and the leakage test shall be made on all sections of sewer.
- C. Infiltration: The infiltration test shall be made where excessive groundwater is encountered.
- D. Retesting: Even though a section may have previously passed the leakage or infiltration test, each section of sewer shall be tested subsequent to the last backfill compacting operation if, in the opinion of the District, heavy compaction equipment or any of the operations of the Contractor or others may have damaged or affected the structural integrity or water tightness of the pipe, structure, and appurtenances.
- E. Other Utilities: Official District tests will not be made until after all the other utilities have been installed and their trench compaction verified.
- F. Excessive Leakage or Infiltration: If the leakage or infiltration rate is greater than the amount specified, the pipe joints shall be repaired or, if necessary, the pipe shall be removed and relaid by the Contractor.
- G. Acceptance: The sewer will not be accepted until the leakage or infiltration rate, as determined by testing, is less than the maximum allowable.
- H. House Laterals: House laterals are not to be connected until after the sewer main has been successfully tested.

3.02 LOW-PRESSURE AIR TEST

- A. Test Section: Each section of sewer between two successive manholes shall be tested by plugging all pipe outlets.
- B. Addition of Air: Air shall be slowly added until the internal pressure is raised to 4.0 pounds per square inch gage (psig). The compressor used to add air to the pipe shall have a blowoff valve set at 5 psig to ensure that at no time the internal pressure in the pipe exceeds 5 psig.
- C. Internal Pressure: The internal pressure of 4 psig shall be maintained for at least two minutes to allow the air temperature to stabilize, after which the air supply shall be disconnected and the pressure allowed to decrease to 3.5 psig.
- D. Pressure Drop: The time in seconds that is required for the internal air pressure to drop from 3.5 psig to 2.5 psig shall be measured and the results compared with the minimum permissible pressure holding times indicated in the following table.
- E. Minimum Pressure Holding Times

1. Vitrified Clay Pipe:

Pipe Diameter (inch)	Time (minutes) per 100 feet of length
6	0.7
8	1.2
10	1.5
12	1.8
15	2.1

2. PVC Pipe:

Pipe Diameter (inch)	Time (minutes) per 100 feet of length
6	5.7
8	7.6
10	9.4
12	11.3
15	14.2

- F. Retest: If the pressure drop from 3.5 psig to 2.5 psig occurs in less time than specified, the pipe shall be repaired and, if necessary, replaced and relaid until the joints and pipe shall hold satisfactorily under this test.

3.03 INFILTRATION TEST

- A. Preparation of Test Section: The end of the sewer at the upper structure shall be closed to prevent the entrance of water, and pumping of groundwater shall be discontinued for at least three days, after which the section shall be tested for infiltration.
- B. Allowable Infiltration Rate: The infiltration shall not exceed 0.025 gpm per inch of diameter per 1,000 feet of main line sewer being tested, not including the length of laterals entering that section.
- C. Excessive Infiltration: Where infiltration in excess of the allowable amount is discovered before completion and acceptance of the sewer, the sewer shall be immediately uncovered and the amount of the infiltration reduced to a quantity within the specified amount of infiltration, before the sewer is accepted.
- D. Individual Leaks: Even if the infiltration is less than the allowable amount, any individual leaks that may be observed shall be stopped as directed by the District.
- E. Completion of Tests: All tests must be completed before the street or trench is resurfaced, unless otherwise directed by the District.

3.04 DEFLECTION TEST

- A. All PVC main line pipe shall be tested for deflection, joint displacement, or other obstruction by passing a rigid mandrel through the pipe by hand.
- B. Conduct deflection test not less than 30 days after completion of the trench backfill, but prior to permanent resurfacing.
- C. The mandrel shall be a full circle cylinder, accepted by the District as to design and manufacture. The circular cross section of the mandrel shall have a diameter as indicated in the following table:

Pipe Diameter (inch)	Minimum Mandrel Diameter (inches)
6	5.31
8	7.09
10	8.84
12	10.51

3.05 NEGATIVE AIR PRESSURE (VACUUM) MANHOLE TEST

- A. Perform test per ASTM C1244 immediately after assembly and prior to backfilling.
 - 1. Draw 10 inches mercury of vacuum on the manhole, close vacuum line valve, and shutoff vacuum pump.
 - 2. Measure time for the vacuum to drop to 9 inches mercury.
 - 3. Minimum test times for the vacuum reading to drop from 10 inches to 9 inches mercury are as follows:

Depth (feet)	48-inch Diameter Manhole	60-inch Diameter Manhole	72-inch Diameter Manhole
	Minimum Test Times (seconds)		
<4	10	13	16
6	15	20	25
8	20	26	33
10	25	33	41
12	30	39	49
14	35	46	57
16	40	52	67
18	45	59	73
20	50	65	81
22	55	72	89
24	59	78	97
26	64	85	105
28	69	91	113
30	74	98	121

- B. All manhole inlets and outlets shall be plugged with approved stoppers or plugs.
- C. If the manhole fails the initial test, necessary repairs shall be made with a non-shrink grout while the vacuum is still being drawn. Cracks longer than two-inches shall be cause for rejection of the casting and no patching shall be allowed. Retesting shall proceed until a satisfactory test is obtained.

END OF SECTION

SECTION 15050

HOT TAP CONNECTIONS

PART 1 GENERAL

1.01 SECTION INCLUDES

- A. Hot tap (system under pressure) connections to existing distribution systems

1.02 RELATED REQUIREMENTS

- A. Section 01045, Existing Facilities
- B. Section 15041, Chlorination of Potable Water Mains and Services for Disinfection
- C. Section 15057, Copper, Brass, and Bronze Pipe Fittings and Appurtenances
- D. Section 15100, Manual Valves

1.03 REFERENCED STANDARDS

- A. American Petroleum Institute (API)
 - 1. API RP 2201: Procedures for Welding or Hot Tapping on Equipment in Service
- B. American Water Works Association
 - 1. AWWA C205: Cement-Mortar Protective Lining and Coating for Steel Water Pipe – 4” (100 mm) and Larger – Shop Applied
 - 2. AWWA C210: Liquid-Epoxy Coating Systems for the Interior and Exterior of Steel Water Pipelines
 - 3. AWWA C213: Fusion-Bonded Epoxy Coating for the Interior and Exterior of Steel Water Pipelines
 - 4. AWWA M11: Steel Water Pipe: A Guide for Design and Installation
- C. NSF International
 - 1. NSF 61: Drinking Water Systems Components – Health Effects

1.04 SUBMITTALS

- A. Hot tap connection plan
- B. Product data sheets
- C. Contractor hot tap project list with contact information for agencies/owners

1.05 QUALITY ASSURANCE

- A. Conform to requirements of API RP 2201.
- B. Hot Tapping Company
 - 1. All hot tapping shall be performed by a District-approved hot tapping company.

PART 2 PRODUCTS

2.01 SERVICE SADDLES AND CORPORATION STOPS

- A. Service saddles and corporation stops shall comply with Section 15057.

2.02 TAPPING SLEEVES

- A. Type:
 - 1. Tapping sleeves for tap diameters smaller than the pipeline diameter: full circle type bolted stainless steel
 - 2. Tapping sleeves for size on size taps:
 - a. Full circle cast iron with mechanical joint end glands
 - b. Interior and exterior epoxy coating per:
 - 1) AWWA C210 or AWWA C213
 - 2) Conform to requirements of NSF 61 for interior coatings.
 - 3. Tapping sleeves onto 14-inch and larger ACP:
 - a. Full circle cast iron with mechanical joint end glands
 - b. Interior and exterior epoxy coating per:
 - 1) AWWA C210 or AWWA C213
 - 2) Conform to requirements of NSF 61 for interior coatings.
- B. Gaskets: Buna-N rubber with a wide cross section
- C. Bolts and trim hardware: Type 316 stainless steel

2.03 TAPPING VALVES

- A. Tapping valves shall be flanged resilient seat wedge gate valves per Section 15100.
- B. All bolts and trim hardware shall be Type 316 stainless steel.

2.04 WELD NOZZLES

- A. Weld nozzles and reinforcing plates shall be fabricated steel per AWWA M11.

PART 3 EXECUTION

3.01 NOTIFICATION

- A. The Contractor shall provide proper notification to the District inspector at least five working days prior to making a hot tap connection.

3.02 VERIFICATION

- A. The Contractor shall pothole the proposed connection to verify the outside diameter, location and type of pipe to be tapped prior to ordering materials.

3.03 SURFACE PREPARATION

- A. The pipe barrel to be tapped shall be thoroughly cleaned with a wire brush to provide a smooth, hard surface for the saddle, sleeve or nozzle.

3.04 SERVICE SADDLE AND CORPORATION STOP

- A. Service saddles and corporation stops will be installed onto ACP, DIP or PVC mains in accordance with the manufacturer's instructions and Section 15057. The outlet shall be oriented to comply with the intended use of the service connection.

3.05 WELD NOZZLES

- A. Nozzles and reinforcing plates are to be welded onto steel pipe shells in accordance with API RP 2201.

3.06 TAPPING SLEEVES

- A. The tapping sleeve shall be installed in accordance with the manufacturer's instructions and to the satisfaction of the District.
- B. The pipe barrel shall be thoroughly cleaned with a wire brush to provide a smooth, hard surface for the sleeve.
- C. The sleeve shall be supported independent of the pipe during the tapping operation.
- D. The sleeve shall be hydrostatically tested in the presence of the District prior to tapping.
- E. Thrust blocks shall be provided at the tapping sleeve.

3.07 TAPPING VALVE

- A. The tapping valve shall be installed on the tapping sleeve or weld nozzle per Section 15100.

3.08 HOT TAP

- A. All taps into existing pipes will be made through a service saddle, tapping sleeve, welded nozzle or welded coupling. Direct taps are not permitted.

- B. The hot tap into the existing pipe shall be made using the appropriate type of cutting machine and shell cutting bit for the material being tapped.
- C. The tapping machine shall be operated per the manufacturer's operating instructions.
- D. Proper care shall be taken to prevent cutting material from entering the pipeline. The tapping coupon must be extracted.

3.09 MORTAR COATING REPAIR

- A. The exterior mortar coating on welded steel pipe shall be repaired in accordance with AWWA C205.

3.10 TESTING

- A. Perform hydrostatic test of hot tap installation in the presence of the District inspector prior to tapping the pipe.
- B. Test pressure:
 - 1. At least equal to the operating pressure of the line to be tapped
 - 2. Not exceeding the present internal pressure by more than approximately 10 percent, in order to avoid possible internal collapse of the pipe or vessel wall

3.11 DISINFECTION

- A. The interior of the tapping valve and connecting piping shall be sprayed with a 1-percent sodium hypochlorite solution prior to connection per requirements of Section 15041.

END OF SECTION

SECTION 15056

DUCTILE-IRON PIPE AND FITTINGS

PART 1 GENERAL

1.01 SECTION INCLUDES

- A. Ductile-iron pipe and fittings

1.02 RELATED REQUIREMENTS

- A. Section 02223, Trenching, Backfilling, and Compacting
- B. Section 03300, Concrete
- C. Section 09900, Painting and Coating
- D. Section 13121, Corrosion Protection
- E. Section 15041, Chlorination of Potable Water Mains and Services for Disinfection
- F. Section 15042, Hydrostatic Testing of Pressure Pipelines

1.03 REFERENCED STANDARDS

- A. AWWA C104: Cement-Mortar Lining for Ductile-Iron Pipe and Fittings
- B. AWWA C105: Polyethylene Encasement for Ductile-Iron Pipe Systems
- C. AWWA C110: Ductile-Iron and Gray-Iron Fittings
- D. AWWA C111: Rubber-Gasket Joints for Ductile-Iron Pressure Pipe and Fittings
- E. AWWA C150: Thickness Design of Ductile-Iron Pipe
- F. AWWA C151: Ductile-Iron Pipe, Centrifugally Cast
- G. AWWA C153: Ductile-Iron Compact Fittings
- H. AWWA C600: Installation of Ductile-Iron Water Mains and Their Appurtenances
- I. ASTM A193: Standard Specification for Alloy-Steel and Stainless Steel Bolting for High Temperature or High Pressure Service and Other Special Purpose Applications
- J. ASTM A194: Standard Specification for Carbon Steel, Alloy Steel, and Stainless Steel Nuts for Bolts for High Pressure or High Temperature Service, or Both
- K. ASTM A536: Standard Specification for Ductile-Iron Castings

1.04 SUBMITTALS

- A. Product data sheets
- B. Thrust restraint calculations

PART 2 PRODUCTS

2.01 DUCTILE-IRON PIPE

- A. Pressure class or thickness class of DIP shall be determined by the design method detailed in AWWA C150 the "Thickness Design Method."
- B. Ductile-iron pipe shall be manufactured in accordance with AWWA C151.
- C. All ductile-iron pipe shall be the pressure class shown on the plans for bell and spigot pipe, pressure Class 350 for plain end pipe and thickness, and Class 53 for flanged spools unless indicated otherwise.
- D. Lining:
 - 1. Potable and recycled water: Cement-mortar lined in accordance with AWWA C104. Lining thickness shall be the double thickness listed in AWWA C104.
 - 2. Sewer: Ceramic epoxy lining
- E. Coating:
 - 1. Buried: factory applied bituminous coating of not less than 1 mil. in thickness
 - 2. Non-buried: primer coat suitable for use with coating system in Section 09900.
- F. Unless otherwise called out on the plans, a push-on type joint shall be used. The joint dimensions and gasket shall be as specified in AWWA C111.
- G. Where restrained joints are called for, provide the following:
 - 1. Restraint harness system for push-on joints:
 - a. Design: Ductile-iron pipe bell restraint system consisting of a wedge action restraint ring on the spigot joined to a split ductile-iron ring behind the bell. Restraint ring incorporates individually actuated wedges. Proper actuation of the wedges achieved through use of torque limiting twist off nuts.
 - b. Design safety factor: 2.0
 - c. Restraint ring and wedging components: Cast iron per ASTM A536, grade 65-45-12
 - d. Gripping wedges: Heat treated ductile-iron with minimum hardness of 370 BHN
 - e. Coating: Fusion bonded polyester, 5 mil thickness
 - f. Restraining rods and clamping fasteners: Type 316 Stainless steel
- H. Flanges for ductile-iron pipe shall be in accordance with AWWA C115.

I. Outlets for DIP shall be as follows:

2" or smaller:	bronze service saddle
2-1/2":	tapped tee or service saddle
4" and larger:	ductile-iron tee fitting

2.02 DUCTILE-IRON FITTINGS

- A. Ductile-iron fittings shall be manufactured in accordance with AWWA C110, or AWWA C153. Compact body fittings, as described in AWWA C153, will not be permitted in vault structures.
- B. Lining: Same as ductile-iron pipe
- C. Coating: Same as ductile-iron pipe
- D. All fittings shall be made with "push-on" joints designed for use with the type of pipe to be joined unless noted otherwise.
- E. Where restrained joints are called for, provide the following:
 - 1. Mechanical joint restraining gland:
 - a. Design: Restraint device consisting of multiple gripping lugs/wedges/pads around the pipe circumference incorporated into a follower gland meeting the applicable requirements of AWWA C110.
 - 1) Specifically designed for the pipe material being connected to coupling
 - 2) Proper actuation of the gripping wedges achieved through use of torque limiting twist off nuts.
 - b. Design safety factor: 2.0
 - c. Gland: Cast iron per ASTM A536, grade 65-45-12
 - d. Gripping lugs/wedges/pads: Heat treated ductile-iron
 - e. Coating: Fusion bonded polyester, 5 mil thickness
 - f. Tie bolts: Type 316 Stainless steel
- F. Unless otherwise indicated on the drawings, all fittings with flanged ends shall be ductile-iron class 150. The gasket surface shall have a serrated finish of approximately 16 serrations per inch, approximately 1/32-inch deep, with serrations in either a concentric or spiral pattern. All flanges shall be flat faced. In addition, all flanges shall meet the following tolerances:

Bolt circle drilling	$\pm 1/16$ inch
Bolt hole spacing	$\pm 1/32$ inch
Eccentricity of bolt circle and	$\pm 1/32$ inch
Maximum facing with respect to bore	
- G. Gray-iron fittings may not be substituted for ductile-iron.

2.03 GASKETS

- A. Flange Gaskets:
 - 1. Gaskets for flanged joints shall be 1/8-inch thick, synthetic-fiber rubber.
 - 2. Full face type gaskets with pre punched holes shall be used where both flanges are flat face. Ring gaskets extending to the inner edge of the bolts may be used where a raised face flange is present.
- B. Push on or mechanical joint gaskets: Rubber gaskets for push on joints shall be synthetic or natural rubber manufactured in accordance with AWWA C111.

2.04 HARDWARE

- A. All bolts and nuts shall be Type 316 stainless steel conforming to ASTM A 193, Grade B8M for bolts, and ASTM A 194, Grade 8M for nuts.
- B. Provide one (1) washer for each nut. Washer shall be of the same material as the nuts.
- C. The length of each bolt or stud shall be such that between 1/4 inch and 3/8 inch will project through the nut when drawn tight.
- D. Tie-bolts for restrained joints shall be Type 316 stainless steel.

2.05 CORROSION GUARD

- A. Water resistant, oxidation inhibiting cosmoline grease or microcrystalline wax-based coating system that adheres to metal surfaces
- B. 345-degree F dropping point

2.06 LUBRICANTS

- A. Lubricant for pipe insertion shall be food grade, and biodegradable.

PART 3 EXECUTION

3.01 GENERAL

- A. Ductile-iron pipe and ductile-iron fittings shall be installed in accordance with the applicable Sections of AWWA C600 and as specified herein.
- B. Where the pipe grade is not shown, the minimum allowable pipe cover is listed below. The pipe grade shall be accepted by the District.
 - a. Distribution Mains (12-inch diameter and smaller): The top of the pipe is to be a minimum of 42 inches below finished grade.
 - b. Transmission Mains (larger than 12-inch diameter): The top of the pipe is to be a minimum of 48 inches below finished grade.

- C. Coat buried stainless steel hardware with corrosion guard. Exposed stainless steel hardware shall not be coated.

3.02 TRENCHING, BACKFILLING, AND COMPACTING

- A. Trenching, backfilling, and compacting shall be in accordance with Section 02223 and as specified herein.

3.03 PLACEMENT OF PIPE IN TRENCH

- A. Lay pipes uphill if the grade exceeds 10-percent.
- B. The radius of curvature of the trench shall determine the maximum length of pipe section that can be used without exceeding the allowable deflection at a joint. Combined deflections at rubber gasket, restrained joint, deflection coupling or flexible coupling joints shall not exceed 50-percent of the manufacturer's recommended deflection.
- C. The manufacturer's printed installation guide outlining the radius of curvature that can be negotiated with pipe sections of various length and the deflection couplings shall be followed if applicable.
- D. The pipe shall be laid true to the line and grade shown on the plans within acceptable tolerances. The tolerance on grade is 1 inch. The tolerance on line is 2 inches.
- E. Fittings shall be supported independently of the pipe.
- F. Until thrust blocks and supports are poured, fittings shall be temporarily supported by placing sand under the bells so that the pipe is not subjected to the weight of the fitting.
- G. Bond all pipe joints with bond wire per Section 13121.

3.04 EXTERIOR PROTECTION

- A. Exterior surface, buried service:
 - 1. Wrap buried flanges, valves, and fittings with 10-mil polyethylene wrap per AWWA C105. Wrap beyond flanges, valves, and fittings by 12 inches on both sides. Wrap all joints in polyethylene wrap with 2-inch wide polyethylene adhesive tape.
 - 2. Apply corrosion guard to all hardware.
- B. Exterior surface, non-buried: Coat all surfaces per Section 09900.

3.05 THRUST RESTRAINT

- A. Construct thrust blocks at all pipe deflection angles greater than 5 degrees, at changes in pipe size, at fittings, at hydrant ells, and at valves.
- B. Install pipe with restrained joints only where shown on the Drawings, or where directed by the District.
- C. Design thrust restraint method used (thrust blocks, restrained joints, etc.) to withstand the maximum internal pipeline pressure created during testing of each particular pipeline.

- D. The area and design of the bearing surface shall be per the Drawings. Submit thrust restraint calculations where soil or pressure parameters differ than as shown on the Drawings.
- E. The bearing surface shall be against wetted undisturbed ground in all cases, except where unstable conditions are encountered. In unstable conditions, the bearing surface shall be as directed by the District.
- F. Unless otherwise directed by the District, the blocking shall be placed so that the pipe and fitting joints are accessible for repair.
- G. The depth of thrust blocks below valves shall conform with the size of the valve and shall be cut into the side of the trench a minimum of 12-inches on each side.

3.06 FLANGED CONNECTIONS

- A. Bolt holes of flanges shall straddle the horizontal and vertical centerlines of the pipe run.
- B. Clean flanges by wire brushing before installing gaskets.
- C. Clean flange bolts and nuts by wire brushing, lubricate threads with anti-seize compound, and tighten nuts uniformly and progressively. Between 1/4 inch and 3/8 inch shall project through the nut when drawn tight.
- D. If flanges leak under pressure testing, loosen or remove the nuts and bolts, reseal or replace the gasket, reinstall or retighten the bolts and nuts, and retest the joints. Joints shall be watertight.

3.07 PIPE SUPPORT

- A. All exposed pipe shall be supported as detailed in the plans.

3.08 DISINFECTION

- A. All potable water piping shall be disinfected by chlorination in accordance with Section 15041.

3.09 TESTING

- A. All potable water and recycled water piping shall be hydrostatically pressure tested in accordance with Section 15042.

END OF SECTION

SECTION 15057

COPPER, BRASS, AND BRONZE PIPE FITTINGS AND APPURTENANCES

PART 1 GENERAL

1.01 SECTION INCLUDES

- A. Copper tubing and fittings
- B. Brass pipe, nipples, and fittings
- C. Brass corporation and angle meter stops, and appurtenances
- D. Bronze saddles and appurtenances

1.02 RELATED REQUIREMENTS

- A. Section 02223, Trenching, Backfilling, and Compacting
- B. Section 13110, Dissimilar Metal Connections
- C. Section 15151, Potable Water, Recycled Water, and Wastewater Facilities Identification

1.03 REFERENCED STANDARDS

- A. ASTM International
 - 1. ASTM A193: Standard Specification for Alloy-Steel and Stainless Steel Bolting for High Temperature of High Pressure Service and Other Special Purpose Applications
 - 2. ASTM A194: Standard Specification for Carbon Steel, Alloy Steel, and Stainless Steel Nuts for Bolts for High Pressure or High Temperature Service, or Both
 - 3. ASTM B32: Standard Specification for Solder Metal
 - 4. ASTM B43: Standard Specification for Seamless Red Brass Pipe, Standard Sizes
 - 5. ASTM B75: Standard Specification for Seamless Copper Tube
 - 6. ASTM B88: Standard Specification for Seamless Copper Water Tube
 - 7. ASTM F467: Standard Specification for Nonferrous Nuts for General Use
 - 8. ASTM F468: Standard Specification for Nonferrous Bolts, Hex Cap Screws, Socket Head Cap Screws, and Studs for General Use
- B. American Water Works Association
 - 1. AWWA C800: Underground Service Line Valves and Fittings
- C. NSF International
 - 1. NSF 61: Drinking Water Systems Components – Health Effects

- D. ASME Boiler and Pressure Vessel Code

1.04 SUBMITTALS

- A. Submit detailed layout if pipe runs in copper exceed 50 linear feet.
- B. Submit catalog order sheets showing material construction and conformance to industry standards (ASTM, etc.) specified. The material data sheets shall indicate NSF certification for materials used on the potable water system.

PART 2 PRODUCTS

2.01 COPPER TUBING AND FITTINGS

- A. Copper tubing shall conform to the requirements of ASTM B88 for seamless copper water tube. Piping located aboveground or suspended within vaults shall be Type L. Buried piping shall be Type K. Copper pipe shall be of domestic manufacture.
- B. Fittings shall be copper conforming to ASTM B75 and ANSI B16.22, with solder end joints. Fittings 3/8 inch and smaller may have flared end connections or compression joint connections.
- C. Solder shall be silver solder conforming to ASTM B32, Grade 95TA. Do not use cored solder.
- D. All copper lines shall be encased within a 8-mil polyethylene sleeve. Sleeves shall be color coded per Section 15151.
- E. Conform to NSF 61.

2.02 BRASS PIPE, NIPPLES, AND FITTINGS

- A. Short threaded nipples, brass pipe, and fittings shall conform to ASTM B43, regular wall thickness, except for nipples and pipe of sizes 1-inch and smaller shall be extra strong. Threads shall conform to ANSI B2.1.
- B. Conform to NSF 61.

2.03 BRASS APPURTENANCES

- A. General: All items specified herein shall be manufactured of brass conforming to AWWA C800 and NSF 61.
- B. Customer service valves:
 - 1. Ball valve type and shall be manufactured of brass, with lever-type turn handle.
 - 2. Inlet connection: Meter flange or a meter coupling
 - 3. Outlet connection: Female iron pipe thread

- C. Corporation stops: Ball valve type and shall be manufactured of brass. The inlet fitting shall be a male iron pipe thread when used with saddle and the outlet connection shall be a flare type.
- D. Angle meter stops: Ball valve type for 3/4-inch and 1-inch services and ground inverted key type for 1-1/2-inch and 2-inch services and shall be manufactured of brass. The inlet connection shall be a flare type or female iron-pipe thread and the outlet fitting shall be a meter flange or meter coupling. The inlet and outlet shall form an angle of 90 degrees on a vertical plane through the centerline of the meter stop. A rectangular lug and lock wing shall be provided on the top of the fitting to operate the shutoff mechanism.

2.04 BRONZE APPURTENANCES

- A. General:
 - 1. All items specified herein shall be manufactured of bronze conforming to AWWA C800 and NSF 61.
- B. Saddles:
 - 1. Design:
 - a. Double-strap with flat straps (or bails)
 - b. Tapped for an iron pipe thread
 - c. The seal with the pipe shall be effected with either a rubber gasket or an O-ring.
 - 2. Material
 - a. Straps (or bails):
 - 1) Silicon bronze for tapping asbestos cement pipe
 - 2) Stainless steel for tapping C900 PVC and ductile iron pipe
 - b. Body: Bronze
 - 3. Flanges, Gaskets, Bolts, and Nuts
- C. Flanges:
 - 1. Connect to flanged valves and fittings with bronze flanges conforming to ANSI B16.24, Class 125 or Class 150, to match the connecting flange. Use solder end companion flanges.
 - 2. Gaskets for flanged-end fittings shall be made of synthetic rubber binder and shall be fullface, 1/8-inch-thick.
 - 3. When both adjoining flanges are bronze, use bronze bolts and nuts. Bolts shall conform to ASTM F468, Grade C65100 or C63000. Nuts shall conform to ASTM F467, Grade C65100 or C63000.
 - 4. When only one of the adjoining flanges is bronze, use type 316 stainless-steel bolts and nuts conforming to ASTM A193, Grade B8M for bolts, and ASTM A194, Grade 8M for nuts.

5. Connect to buried ferrous flanges with flange insulation kits. Bolts used in flange insulation kits shall conform to ASTM A193, Grade B7. Nuts shall comply with ASTM A194, Grade 2H. If the adjoining buried flange is bronze, use bronze bolts and nuts as described above, without a flange insulation kit.
6. Provide one (1) washer for each nut. Each washer shall be of the same material as the nut.

PART 3 EXECUTION

3.01 COPPER TUBING AND FITTINGS

- A. Cut tubing square and remove burrs. Clean both the inside and outside of fitting and pipe ends with steel wool and muriatic acid before soldering. Prevent annealing of fittings and tubing when making connections. Do not miter joints for elbows or notch straight runs of pipe for tees.
- B. Bends in soft copper tubing shall be long sweep. Shape bends with shaping tools. Form bends without flattening, buckling, or thinning the tubing wall at any point.
- C. Brazing procedures shall be in accordance with Articles XII and XIII, Section IX, of the ASME Boiler and Pressure Vessel Code. Silver solder shall be used. Solder shall penetrate to the full depth of the cup in joints and fittings. Solderers shall comply with ANSI B31.3, paragraph 328.
- D. Buried piping shall be installed with some slack to provide flexibility in the event of a load due to settlement, expansion or contraction. A minimum cover of 36 inches below the finished street grade shall be adhered to. The tubing is to be bedded and covered with sand or select material as determined by the District.
- E. All potable service laterals shall be 3/4-inch minimum size copper tubing. End connections shall be flare type.
- F. All 2-inch size services shall be installed with straight lengths of soft copper water tube Type K. Flare fittings are acceptable on only the corporation stop and angle meter stop. All couplings and adapters shall be silver soldered.
- G. The service line shall extend perpendicular to the centerline of the street from the water main to the meter stop or structure, except in a cul-de-sac, where the service shall run in a straight line from the water main to the meter stop.
- H. The service line shall be placed within an 8-mil polyethylene sleeve, color-coded for the type of service. The ends and splices in the sleeve shall be sealed with 20-mil tape.

3.02 SERVICE SADDLE

- A. The service saddle shall be no closer than 18 inches to a valve, coupling, joint, or fitting.
- B. The surface of the pipe shall be filed to remove all loose material and to provide a hard, clean surface before placing the service saddle.

- C. The service saddle shall be tightened per manufacturer's recommendation. Care shall be used to prevent damage or distortion of either the corporation stop or service saddle by over tightening.
- D. The tap into the pipe shall be made in accordance with the pipe manufacturer's recommendation.

3.03 INSTALLING FLANGE BOLTS AND NUTS

- A. Lubricate bolt threads with anti-seize compound prior to installation.
- B. Set flanged pipe with the flange bolt holes straddling the pipe horizontal and vertical centerlines.

3.04 DISSIMILAR METALS

- A. Isolate dissimilar metals per Section 13110.

3.05 BACKFILL MATERIAL

- A. The pipe zone material for all service laterals shall be compacted sand per Section 02223.

END OF SECTION

SECTION 15064

PVC PRESSURE DISTRIBUTION PIPE

PART 1 GENERAL

1.01 SECTION INCLUDES

- A. Polyvinyl chloride (PVC) pressure distribution pipe

1.02 RELATED REQUIREMENTS

- A. Section 02223, Trenching, Backfilling, and Compacting
- B. Section 03300, Concrete
- C. Section 15041, Chlorination of Potable Water Mains and Services for Disinfection
- D. Section 15042, Hydrostatic Testing of Pressure Pipe
- E. Section 15050, Hot Tap Connections
- F. Section 15056, Ductile-Iron Pipe and Fittings
- G. Section 15100, Manual Valves
- H. Section 15151, Potable Water, Recycled Water, and Wastewater Facilities Identification

1.03 REFERENCED STANDARDS

- A. American Water Works Association
 - 1. AWWA C110: Ductile-Iron and Gray-Iron Fittings
 - 2. AWWA C153: Ductile-Iron Compact Fittings
 - 3. AWWA C210: Liquid-Epoxy Coating Systems for the Interior and Exterior of Steel Water Pipelines
 - 4. AWWA C213: Fusion-Bonded Epoxy Coating for the Interior and Exterior of Steel Water Pipelines
 - 5. AWWA C900: Polyvinyl Chloride (PVC) Pressure Pipe and Fabricated Fittings, 4 In. Through 12 In., for Water Transmission and Distribution
 - 6. AWWA C905: Polyvinyl Chloride (PVC) Pressure Pipe and Fabricated Fittings, 14 In. through 48 In., for Water Transmission and Distribution

1.04 SUBMITTALS

- A. Product data sheets
- B. Thrust restraint calculations

1.05 QUALITY ASSURANCE

- A. Conform to AWWA C900 unless noted otherwise below.

PART 2 PRODUCTS

2.01 PVC PIPE

- A. PVC pipe shall be manufactured in accordance with AWWA C900. The pipe shall have gasket bell end or plain end with elastomeric gasket coupling.
- B. Laying lengths shall be 20 feet with the manufacturer's option to supply up to 15-percent random (minimum length 10 feet).
- C. Each pipe length shall be marked showing the nominal pipe size and O.D. base, the AWWA pressure class, and the AWWA specification designation (AWWA C900). For potable water application, the seal of the testing agency that verified the suitability of the material for such service shall be included.
- D. Pipe for recycled lines shall be purple in color and marked as detailed in Section 15151.
- E. Where restrained joints are called for, provide the following:
 - 1. Restraint harness system for push-on joints:
 - a. Design: Ductile-iron pipe bell restraint system consisting of a wedge action restraint ring on the spigot joined to a split ductile-iron ring behind the bell. Restraint ring incorporates individually actuated wedges. Proper actuation of the wedges achieved through use of torque limiting twist off nuts.
 - b. Design safety factor: 2.0
 - c. Restraint ring and wedging components: Cast iron per ASTM A536, grade 65-45-12
 - d. Gripping wedges: Heat treated ductile-iron with minimum hardness of 370 BHN
 - e. Coating: epoxy per AWWA C210 or AWWA C213
 - f. Restraining rods and clamping fasteners: Type 316 Stainless steel

2.02 FITTINGS

- A. Fittings shall be ductile-iron conforming to Section 15056.

2.03 LUBRICANTS

- A. Lubricant for pipe insertion shall be food grade, and biodegradable.

2.04 LOCATOR WIRE

- A. No. 10 AWG copper wire with insulating suitable for direct burial
- B. The insulation shall be blue for potable water, purple for recycled water, and green for pressurized sewer lines.

PART 3 EXECUTION

3.01 GENERAL

- A. The Contractor shall install all the pipe, closure sections, fittings, valves, and appurtenances shown including pipe supports, bolts, nuts, gaskets, and jointing materials.
- B. At all times when the work of installing pipe is not in progress, all openings into the pipe and the ends of the pipe in the trenches or structure shall be kept tightly closed to prevent the entrance of animals and foreign materials. The Contractor shall maintain the inside of the pipe clean, sanitary, and free from foreign materials until its acceptance by the District.
- C. Where closure sections are required by the Contractor's installation operations, the sections shall be installed in accordance with the applicable sections of these specifications.
- D. The pipe sections shall be laid in the trench to true alignment and grade in accordance with the drawings.
- E. Where the pipe grade is not shown, the minimum allowable pipe cover is listed below. The pipe grade shall be accepted by the District.
 - a. Distribution Mains (12-inch diameter and smaller): The top of the pipe is to be a minimum of 42 inches below finished grade.
 - b. Transmission Mains (larger than 12-inch diameter): The top of the pipe is to be a minimum of 48 inches below finished grade.
- F. Curved Pipe Alignments:
 - 1. Limit pipe joint or coupling deflection to 50-percent of manufacturer's published allowable amount.
 - 2. Longitudinal bending of pipe barrel:
 - a. Limit bend radius to no less than 200-percent of manufacturer's published allowable amount.
 - 1) Ensure a constant bend radius is achieved throughout the length of each pipe section and ensure there are no points of a shorter bend radius (i.e. tighter curvature).
 - b. Do not deflect joints when also longitudinally bending the pipe barrel.
 - 1) Implement construction measures to prevent any deflection of the joints when longitudinally bending the pipe barrel.
 - 3. Install couplings or elbow fittings as necessary to achieve greater deflection.

3.02 INSTALLATION

- A. Trenching, backfilling, and compacting shall be in accordance with Section 02223 and as specified herein.
- B. Proper care shall be used to prevent damage in handling, moving, and placing the pipe. Tools and equipment satisfactory to the District shall be provided and used by the Contractor.
- C. The Contractor shall take all necessary precautions to prevent the pipe from floating due to water entering the trench from any source, shall assume full responsibility for any damage due to this cause, and shall pay for and perform the work to restore and replace the pipe to its specified condition and grade if any displacement occurs due to floating.
- D. Excavate bell holes at each joint to permit proper assembly and inspection of the entire joint.
- E. All connecting parts of pipe, rings, couplings, and castings shall be cleaned before assembly. After bearing has been obtained, couplings shall be assembled in a proper manner (as determined by the District). The use of excessive lubricant will not be permitted, and the assembly of the couplings and rings shall be in accordance with the manufacturer's recommendations. Lubricant and rubber rings shall be supplied by the pipe manufacturer. All fittings and valves shall have joints that match the type of adjoining pipe.
- F. All fittings and valves shall be supported so that the pipe is not subjected to the weight of these appurtenances.
- G. Install locating wire above pipe as shown on the Drawings.
 - 1. Bring locating wire to within 6 inches of finish grade at valve locations.
 - 2. Wire shall be accessible by removing the valve can cover. The wire shall be brought up the outside of the valve well and folded over between the inside of the valve can and the valve well.
 - 3. The wire shall not be spliced at any point, and shall be continuous from riser to riser.

3.03 INSTALLATIONS WITHIN JACKED CASING

- A. Certain portions of the project, such as crossings of some roads, highways, and railroads, may be required to be installed within a jacked casing pipe.
- B. Work shall not proceed without permission of the District.
- C. All pipe installed within a casing shall have restrained joints.

3.04 TAPPING

- A. Hot tap connections per Section 15050.

3.05 PIPE IDENTIFICATION

- A. Warning and locator tape and locator wire shall be installed on all on-site recycled water pipelines and potable water piping installed within the limits of a non-potable irrigation system. The pipe identification shall be in accordance with Section 15151.

3.06 LOCATOR WIRE

- A. Install #10 AWG copper wire with insulating suitable for direct burial over the top of the pipe as shown on the Drawings.
- B. The insulation shall be blue for potable water, green for sewer lines, and purple for recycled water.
- C. The wire shall not be spliced at any point, and shall be continuous from riser to riser.
- D. The wire shall be brought to the surface at valve locations and shall be accessible by removing the valve can cover. The wire shall be brought up the outside of the valve well and folded over between the inside of the valve can and the valve well. The wire shall be brought to within 6 inches of finish grade.

3.07 THRUST RESTRAINT

- A. Conform to requirements of Section 15056.

3.08 CHLORINATION

- A. All potable water pipelines shall successfully be chlorinated in accordance with Section 15041 prior to connection to the existing distribution system.

3.09 HYDROSTATIC TESTING

- A. All pipelines shall pass a hydrostatic pressure test in accordance with Section 15042.

END OF SECTION

SECTION 15066

GRAVITY SEWER PIPELINES

PART 1 GENERAL

1.01 SECTION INCLUDES

- A. Gravity sewer pipelines
 - 1. Vitriified clay pipe (VCP)
 - 2. Polyvinyl chloride (PVC) pipe

1.02 RELATED REQUIREMENTS

- A. Section 02223, Trenching, Backfilling, and Compacting
- B. Section 03461, Precast Reinforced Concrete Manholes
- C. Section 15043, Testing of Non-Pressure Sewer Pipelines and Manholes
- D. Section 15068, Sewer Laterals

1.03 REFERENCED STANDARDS

- A. ASTM International
 - 1. ASTM C301: Standard Test Methods for Vitriified Clay Pipe
 - 2. ASTM C425: Standard Specification for Compression Joints for Vitriified Clay Pipe and Fittings
 - 3. ASTM C700: Standard Specification for Vitriified Clay Pipe, Extra Strength, Standard Strength, and Perforated
 - 4. ASTM D395: Standard Test Methods for Rubber Property – Compression Set
 - 5. ASTM D412: Standard Test Methods for Vulcanized Rubber and Thermoplastic Elastomers - Tension
 - 6. ASTM D573: Standard Test Method for Rubber – Deterioration in an Air Oven
 - 7. ASTM D1149: Standard Test Methods for Rubber Deterioration – Cracking in an Ozone Controlled Environment
 - 8. ASTM D1784: Standard Specification for Rigid Poly (Vinyl Chloride) (PVC) Compounds and Chlorinated Poly (Vinyl Chloride) (CPVC) Compounds
 - 9. ASTM D2240: Standard Test Method for Rubber Property – Durometer Hardness
 - 10. ASTM D3034: Standard Specification for Type PSM Poly (Vinyl Chloride) (PVC) Sewer Pipe and Fittings

- B. National Association of Sewer Service Companies (NASSCO)
 - 1. Pipeline Assessment Certification Program (PACP)

1.04 SUBMITTALS

- A. Vitrified Clay Pipe
 - 1. Provide certificates of compliance with all standards referenced in this section to the District.
 - 2. Provide copies of the manufacturer’s required tests of the following conducted on project pipe:
 - a. Crushing test
 - b. Record of retests and rejections
- B. PVC Gravity Sewer Pipe
 - 1. Provide materials list showing material of pipe and fittings with ASTM references and grade.
 - 2. Provide certificates of compliance with all standards referenced in this section to the District.
- C. Installation
 - 1. An installation schedule (tabulated layout) shall be submitted which includes:
 - a. Order of installation and closures
 - b. Pipe centerline station and elevation at each change of grade and alignment
 - c. Locations of manholes

1.05 DELIVERY, STORAGE AND HANDLING

- A. Per manufacturer’s recommendations and the following:
 - 1. Onsite Storage Limitation: Onsite pipe storage shall be protected from UV exposure and limited to a maximum of one week, unless exception is accepted by the District.
 - 2. Care of Pipe: At times when the pipe laying is not in progress, the open end of the pipe shall be closed with a tight-fitting cap or plug to prevent the entrance of foreign matter into the pipe. These provisions shall apply at all times. In no event shall the sewers be used as drains for removing water which has infiltrated into the construction trenches.
 - 3. Moving Pipe: Pipes shall be lifted with handling beams or wide belt slings as recommended by the pipe manufacturer. Cable slings shall not be used. Pipe shall be handled in a manner to avoid damage to the pipe. Pipe shall not be dropped or dumped from trucks or into trenches under any circumstances.
 - 4. Inspection of Pipe: The pipe and accessories shall be inspected for defects prior to lowering into the trench. Any defective, damaged or unsound pipe in the District’s determination shall be replaced at no additional cost to the District. All foreign matter or dirt shall be removed from the interior of the pipe before lowering into position in the trench.

PART 2 PRODUCTS

2.01 VITRIFIED CLAY PIPE (VCP)

- A. General: All VCP and fittings shall be of one class; designated extra strength; of the best quality; vitrified; homogenous in structure; thoroughly burned through their entire thickness; impervious to moisture; sound; and free from cracks, checks, blister, broken extremities, or other imperfections. Pipe shall be bell and spigot pipe unless otherwise specified. Pipe ends shall be square with the longitudinal axis, and sockets shall be true, circular, and concentric with the barrel of the pipe. The thickness of the shell, the depth of the socket, and the dimension of the annular space shall be within the limits of permissible variation to dimension standards of the specifications of ASTM C700, for the size of pipe indicated on the plans.
- B. Pipe Marking: All pipe or fittings shall be clearly marked with the name of the manufacturer or with a trademark and with the size and strength of the pipe as shown on the plans and as herein specified.
- C. Source Testing:
 - 1. Perform factory test of pipes per requirements in ASTM C301.
 - 2. Tests shall be witnessed by a reputable testing laboratory. Pipe selected for testing shall be delivered to the place and at the time designated by the testing laboratory. All costs of furnishing, transporting, and handling the pipe for testing and conducting the tests shall be borne by the Contractor.
 - 3. In lieu of witnessing by a testing laboratory, a certified statement from the pipe manufacturer may be furnished stating that all prescribed tests have been made and the pipe to be used on the project has met all requirements of the specifications.
 - 4. The testing laboratory shall select, at random, for testing as herein specified, no less than 0.5-percent of the number of pipe sections in each size of pipe furnished, except that no less than two specimens shall be tested.
 - 5. The specimens selected for testing shall be sound pipe having dimensions consistent with these specifications. The lot or lots from which the tests samples are taken shall be sufficient to fill the entire order for that size of pipe used in the work under the contract and, if they pass the tests, shall be so designated and marked.
 - 6. All pipe shall be subject to inspection at the factory, trench, or other point of delivery by the District. The purpose of the inspection shall be to cull and reject any pipe that, independent of the physical tests herein specified, fails to conform to the requirements of these specifications or that may have been damaged during transportation or in subsequent handling.
 - 7. If all of the minimum designated percentage or number of the specimens tested meet the requirements of the test, then all of the pipe in the lot, shipment, or delivery corresponding to the sizes and classes so tested shall be considered as complying with the test. If, however, 10-percent or more of the specimens tested fail to meet the requirements of the test or if more than one specimen fails to meet the requirements of the test when the number to be tested is less than ten, then a second selection of pipe shall be made for that test. The number of specimens to be tested in the second selection of pipe shall be five for each specimen of the first selection that failed to meet the requirements.

8. If 90-percent or more of the specimens tested, including those first tested, meet the requirements of the test, all the pipe in the lot, shipment, or delivery corresponding to the sizes and classes so tested shall be considered as complying with that test, otherwise all pipe of these sizes and classes shall be rejected.
 9. Causes for Rejection: The following imperfections in a pipe or special fitting shall be considered injurious and cause for rejection without consideration of the test results specified above.
 - a. A single crack in the barrel of the pipe
 - b. Surface imperfections, such as lumps, blisters, pits or flakes, on the interior surface of a pipe or fitting
 - c. When the bore or socket of the pipe varies from a true circle more than 3-percent of its nominal diameter
 - d. If the pipe or fitting is designated to be straight and it deviates from a straight line more than 1/16-inch per lineal foot. The deviation shall be measured from a straight edge at a point midway between the ends of the pipe.
 - e. A joint of pipe with a piece broken from either the socket or spigot end
 - f. Pipe joints that have tramp clays, grog or other foreign matter flushed permanently to the exterior or interior surface of the pipe or fittings
- D. Joints: All VCP fittings shall be furnished with compression joints.
1. The compression joint on the spigot and bell ends of the pipe shall be factory made of plastisol, polyurethane elastomer, or other approved resilient element bonded onto the outside of the spigot and the inside of the bell to the pipe and molded and cured to a uniform hardness and compressibility to form a tight compression coupling when assembled. Materials for compression joints shall conform to ASTM C425.
 2. Where pipe from different manufacturers is to be jointed together, an adapter pipe with the proper matching joint on each end for the respective manufacturer or an adapter with bushing or sleeves and stainless steel bands, matching each pipe end shall be used. Hot poured joints or concrete encasement of plain end joints shall not be permitted.
- E. Branches: Branches of the type shown on the plans shall be furnished with connections of the sizes specified and shall be securely and completely fastened to the barrel of the pipe in the process of manufacture. Tee branches shall have their axis perpendicular to the longitudinal axis of the pipe. Wye branches shall have their axis approximately 45 degrees (unless otherwise specified on the plans) to the longitudinal axis of the pipe, measured from the socket end. All branches shall terminate in sockets and the barrel of the branch shall be of sufficient length to permit making a proper joint.
- F. Stoppers: The stoppers for all pipe 8-inches in diameter and smaller, in which a sealing component for a flexible compression-type joint is cast, shall be neoprene, polyethylene, or polyurethane. Stoppers in all other cases shall be discs of the same material as the pipe, equal in diameter to the outside of the pipe barrel, and made and installed as accepted by the District.

1. Neoprene stoppers shall be manufactured from a compound containing not less than 50 percent neoprene by volume, which shall be the sole elastomer. Stoppers shall not be adversely affected when exposed to the chemical and bacteriological environments normally found in wastewater.
2. When installed and braced in place in branch spurs, stoppers shall withstand a hydrostatic pressure test of 10 psi with no leakage. When unbraced, stoppers shall remain in place when subjected to a maximum air pressure test of 5 psi.

2.02 POLYVINYL CHLORIDE (PVC) PIPE

A. Pipe and Fittings

1. ASTM Requirements: Pipe, fittings, couplings, and joints shall be in conformance with the size, material and performance requirements of ASTM D3034, SDR 35, and shall have gasketed joints. Pipe shall be made of PVC plastic having a cell classification of 12364 or 12454 as defined in ASTM D1784. Fittings shall be made of PVC plastic having a cell classification of 12454. All pipe shall be of solid wall construction with smooth interior and exterior surfaces.
2. Manufacturer's Testing Certification: During production of the pipe, the manufacturer shall perform the specified tests for each pipe marking. A certification by the manufacturer indicating compliance with specification requirements shall be delivered with the pipe. The certification shall include the test result data.
3. Pipe Marking: All pipe, fittings, and couplings shall be clearly marked at an interval not to exceed 5-feet as follows:
 - a. Nominal pipe diameter
 - b. PVC cell classification
 - c. Company, plant, shift, ASTM, SDR, and date designation
 - d. Service designation or legend

For fittings and couplings, the SDR designation is not required. All pipe shall have a home mark on the spigot end to indicate proper penetration when the joint is made.

4. Additional Pipe Tests Following Delivery: When pipe is delivered to the jobsite, the District may require additional testing to determine conformance with the requirements of pipe flattening, impact resistance, pipe stiffness, and extrusion quality. When testing is required, one test pipe shall be selected at random by the District from each 1,200 feet or fraction thereof of each size of pipe delivered to the jobsite but not less than one test pipe per lot. A lot shall be defined as pipe having the same identification marking. The length of specimen for each selected pipe shall be a minimum of 8-feet.
5. Pipe Retest: Pipe which is not installed within 120 days of the latest test shall not be used without prior acceptance by the District.
6. Fitting and Coupling End Configurations: The socket and spigot configurations for fittings and couplings shall be compatible with those used for the pipe.

B. Gaskets for PVC Pipe

1. General: Unless otherwise specified, gaskets shall be manufactured from a synthetic elastomer, and shall be extruded or molded and cured in such a manner as to be dense, homogeneous and of smooth surface, free of pitting, blisters, porosity, and other imperfections. The compound shall contain not less than 50 percent by volume of first-grade synthetic rubber. The remainder of the compound shall consist of pulverized fillers free of rubber substitutes, reclaimed rubber, and deleterious substances. The tolerance for any diameter measured at any cross section shall be $\leq 1/32$ -inch (.8mm).
2. Gasket Material Requirements: When required by the District, the Contractor shall furnish test samples of gaskets from each batch used in the work. Gasket material shall meet the following requirements:

Property	Value	ASTM Test Method
Tensile Strength (min. psi)	2,000	D412
Elongation at break (% min.)	350	D412
Shore durometer, Type A (Pipe manufacturer shall select value suitable for type of joint)	40 to 65*	D2240
Compression set (constant deflection) max % of original deflection	16	D395
Compression strength after oven aging (96 hours, 158°F {70°C}) % of tensile strength before aging	80	D573
Increase in Shore durometer hardness after oven aging. Maximum increase over original Shore durometer	10	D2240
Physical requirements after exposure to ozone concentration (150 pphm. 70 hours, 140°F {40°C}), 20% strain)	No Cracks	D1149

*This applies only to the sealing component of the gasket.

PART 3 EXECUTION

3.01 PLACEMENT OF PIPE IN TRENCH

A. General:

1. The Contractor shall follow all manufacturer’s installation instructions. If conflicts exist between manufacturer’s installation instructions and this specification, the more stringent requirements shall be used.
2. All pipe shall be laid to the line and grade given to form a close concentric joint with the adjoining pipe and prevent sudden offsets of the flow line. Pipe shall be laid from the downstream structure to the upstream structure, without grade breaks, with the bell ends of the pipe upstream.

- B. Trench Excavation: Dewatering, excavation, shoring, sheeting, bracing, backfill material placement, material compaction, compaction testing, and pipe laying requirements and limitations shall be in accordance with Section 02223.
- C. Subgrade at Joints: At each joint in the pipe, the pipe subgrade shall be recessed in firm bedding material so as to relieve the bell of the pipe of all load and to ensure continuous bearing along the pipe barrel.
- D. Cleaning: The interior of the sewer pipe shall be cleaned of all dirt and superfluous materials as the work progresses.
- E. Joints: The mating surfaces of the pipe to be joined shall be wiped clean of all dirt and foreign matter and a lubricant applied that is approved by the pipe manufacturer. Then, with the surfaces properly lubricated, the spigot end of the pipe shall be positioned inside the bell and the joint shoved home.
- F. For larger diameter pipe where a lever attachment is required, the necessary precautions shall be taken to insure an undamaged pipe installation.
- G. Pipe Alignment: Unless specified otherwise, pipeline line and grade shall be as shown on the plans. Grade shall be measured along the pipe invert.
- H. PVC Pipe Curvature:
 - 1. Construction of curved reaches of PVC pipe shall not be accomplished by deflecting joints or by beveling pipe ends.
 - 2. Longitudinal bending of pipe barrel:
 - a. Limit bend radius to no less than 200-percent of manufacturer's published allowable amount.
 - 1) Ensure a constant bend radius is achieved throughout the length of each pipe section and ensure there are no points of a shorter bend radius (i.e. tighter curvature).
 - b. Do not deflect joints when also longitudinally bending the pipe barrel.
 - 1) Implement construction measures to prevent any deflection of the joints when longitudinally bending the pipe barrel.
- I. Short Lengths of VCP Pipe: When using VCP, two 1-foot lengths of sewer pipe shall be used to provide curve flexibility and prevent cracking or shearing failures as shown on the plans or as may be required by the District during construction. The use of short lengths of pipe is particularly required, but not necessarily limited to these locations: (1) inlets and outlets to all manholes; (2) ends of steel casing pipe; (3) ends of concrete encasement; (4) vertical and horizontal curvilinear sewers; and (5) deep lateral connections.
- J. Backfill: Backfill shall be placed and compacted in accordance with the requirements of Section 02223. Backfill within the pipe zone shall be 3/4-inch crushed rock for PVC pipe and VCP. Wrap rock with filter fabric.

3.02 CLEANING

- A. Before testing, each pipe shall be thoroughly cleaned from manhole to manhole with a sewer scrubbing ball, and all debris and trash shall be removed from each manhole.

3.03 TESTING

- A. The pipe, manholes, and other appurtenances shall be tested for leakage and infiltration per Section 15043.

3.04 CLOSED-CIRCUIT TELEVISION INSPECTION

- A. General: In addition to the regular leakage and infiltration test, the entire length of all new sewer lines shall be inspected using closed-circuit television equipment. The inspection shall be conducted after the line has been successfully tested and prior to paving. The inspection shall be conducted in the presence of the District.
- B. Responsibility: All labor and equipment necessary to conduct this inspection shall be furnished by the Contractor.
- C. Notification: Requests for sewer line inspection shall be made to the District a minimum of five working days in advance of the requested inspection date.
- D. Flushing: Each sewer section shall be flushed with water being introduced at the upstream manhole of each section prior to video recording.
- E. Stationing: The video shall show stationing corresponding to sewer stationing shown on plans for each manhole and wye location.
- F. Sag Gauge: All closed-circuit television equipment shall be installed with a sag gauge visible in the video to determine sag depths.
- G. Submittal: The video shall be MPEG format compatible with the District's current viewer software and shall be submitted to the District with reports showing manhole numbers and stationing, wye stationing, and distance between manholes prior to Final Acceptance of the project by the District. The electronic file and reports shall be labeled with the project name, tract number, street names, and the Contractor's name and shall list the station of any defects, dirt, sags, etc. in the pipe. Reports and videos shall include defect coding in accordance with the National Association of Sewer Service Companies (NASSCO) Pipeline Assessment Certification Program (PACP).
- H. Repair of Defects: Even though the sewer line may have successfully passed the leakage and infiltration tests, any defects or sags in the line shall be repaired to the satisfaction of the District.
- I. Acceptance: Any sewer section having sags or defects shall be repaired by the Contractor prior to Final Acceptance of the project by the District. Sags in the line will not be allowed.

3.05 FINAL INSPECTION

- A. After paving has been completed and all manholes raised to grade, a final visual inspection shall be made. The necessary labor shall be furnished to assist the District in making the final inspection. Additional cleaning may be required if the lines are dirty, even though lines were previously cleaned. The Contractor shall furnish a responsible person or supervisor for the final inspection to remove manhole covers and to note any corrections required by the District in order to obtain final acceptance. Final District inspection shall be requested through the District by giving at least five days of notice.

END OF SECTION

SECTION 15068
SEWER LATERALS

PART 1 GENERAL

1.01 SECTION INCLUDES

- A. Vitrified clay pipe (VCP) sewer laterals
- B. Polyvinyl chloride (PVC) pipe sewer laterals
- C. Flexible saddles

1.02 RELATED REQUIREMENTS

- A. Section 02223, Trenching, Backfilling, and Compacting
- B. Section 15043, Testing of Non-Pressure Sewer Pipelines and Manholes
- C. Section 15066, Gravity Sewer Pipelines

1.03 REFERENCE STANDARDS

- A. ASTM International
 - 1. ASTM D5926: Standard Specification for Poly (Vinyl Chloride) (PVC) Gaskets for Drain, Waste, and Vent (DWV), Sewer, Sanitary, and Storm Plumbing Systems

1.04 SUBMITTALS

- A. Shop drawings shall be submitted in accordance with the General Provisions and as specified herein.
- B. An installation schedule (tabulated layout) shall be submitted which includes:
 - 1. Order of installation and closures
 - 2. Pipe centerline station and elevation at each change of grade and alignment
- C. Lateral elevation certification

PART 2 PRODUCTS

2.01 PIPE AND FITTINGS

- A. Refer to Section 15066 for product requirements.

2.02 SADDLES

- A. Banded flexible saddle wye
 - 1. Conform to ASTM D5926
 - 2. High durometer PVC
 - 3. Groove bands for straps
 - 4. Root-proof and leak-proof
- B. Straps and hardware shall be 316 Stainless Steel.

PART 3 EXECUTION

3.01 INSTALLATION

- A. Installation of pipe, fittings, and saddles shall be in accordance with manufacturer's recommendations and these specifications.

3.02 LATERALS

- A. General: VCP and PVC wyes, and other types of branches shall be furnished and installed along with the VCP or PVC sewer. Wyes sized as specified on the plans shall be installed for all sewer house connections and for future sewer house connections as shown on the plans. The longitudinal barrel of branch fittings, to be placed in line and grade with the sewer mains, shall be of the same diameter, quality, and type as specified herein for sewer installations. Earthwork and bedding for branches shall conform to the applicable provisions set forth in the specification for each pipe material. Unless otherwise specified, the branch of wye fittings shall be inclined upward at an angle not greater than 45 degrees from a horizontal line. The Contractor shall place a support of graded crushed rock under every wye branch when installed.
- B. Sequencing: Laterals shall be installed after mass grading is finished and before other utilities are installed.
- C. Lateral Elevation Certification: Certify the elevation of the house lateral and connection point.
- D. Locations: House laterals and wye branch fittings of the size indicated on the plans shall be installed at the locations shown on the plans or at the location furnished by the District.
- E. Plugged Branches: All branch fittings that are to be left unconnected shall be plugged or capped.
- F. Fittings: House laterals shall be joined to wye branch fittings at the sewer main as set forth above by eighth bends. All eighth bends and sixteenth bends are considered part of house lateral sewer line.
- G. Alignment: Where possible, all house laterals shall run perpendicular to the sewer main from the main to the property line, and all house laterals shall be bedded the same as the sewer main into which they connect.

- H. Plugged House Laterals: All house laterals shall be plugged with an approved stopper in the socket of the last joint of each house lateral so that it will withstand the internal pressure during the test for leakage, but also in such a manner that it may be removed without injury to the socket.
- I. Marking: The Contractor shall mark the location of each sewer lateral at its upper end by chiseling a letter "S" 2-inches high on the face of the curb.
- J. Chimney Connections: Chimney connections are not allowed.
- K. Mainline Testing: The mainline sewer shall have passed final testing per Section 15043 before the laterals may be connected to the main.
- L. Inspection: The District shall be notified at least five days in advance of and be present to inspect all connections to the public sewer mains.

3.03 SADDLE CONNECTIONS

- A. Scoring and Tapping: The sewer line to be saddled shall be scored to the approximate shape of the wye and shall be cut with a hole cutter. The tap holes shall be cleanly machined and may be further worked by hand to provide a true and neat opening for the saddle wye. Pipe damaged during this operation shall be repaired or replaced, using a method that is acceptable to the District.
- B. Installation: Install banded flexible saddle wye per manufacturer's instructions.
- C. Encasement: After installation of the saddle, the District will inspect the connection and, if satisfactory, the Contractor shall encase the saddle with 3/4-inch crushed rock. Vibrate crushed rock to compact.
- D. Cleaning: The saddling operation shall be carried out in a workmanlike manner. Chips, dirt, concrete, and other debris shall be kept out of the sewer line being saddled. If directed by the District, the reach of sewer main saddled shall be flushed and cleaned using a hydrocleaner or vacuum truck.
- E. Cut-in Wye: Where lateral connection is size-on-size, a wye connection shall be made by installing a cut-in wye.

END OF SECTION

SECTION 15072

DISPOSAL OF ASBESTOS CEMENT PIPE

PART 1 GENERAL

1.01 SECTION INCLUDES

- A. Connection to and disposal of existing asbestos cement distribution pipe (ACP)

1.02 RELATED REQUIREMENTS

- A. Section 15064, PVC Pressure Distribution Pipe
- B. Section 15162, Pipe Couplings and Adapters

1.03 REFERENCED STANDARDS

- A. California Code of Regulations (CCR), Title 8, Section 1529, Asbestos
- B. ASTM D4397: Standard Specification for Polyethylene Sheeting for Construction, Industrial, and Agricultural Applications

1.04 SUBMITTAL

- A. Copies of the Contractor's certification from the Contractors State Licensing Board for asbestos removal shall be submitted to the District prior to the commencement of any asbestos removal activities.
- B. The Contractor is to provide manifests/disposal records to the District.

1.05 QUALITY ASSURANCE

- A. Cutting, removal, handling, and disposal of ACP shall be performed by a Contractor registered by the California Division of Occupational Safety and Health (Cal/OSHA) and certified by the Contractors State Licensing Board for asbestos removal.
- B. The Contractor or subcontractor shall comply with all State and Federal laws regarding handling and removal of asbestos materials. The Contractor shall provide sufficient supervision and monitoring to assure said conformance.
- C. Workers handling ACP shall be trained in accordance with applicable State regulations.
- D. Comply with requirements of CCR Title 8, Section 1529.

1.06 HEALTH HAZARD

- A. The Contractor is warned that asbestos is a known human carcinogen and poses serious health risks. Asbestos fibers are easily inhaled and can result in chronic respiratory illness, cancer, and other severe health effects.

PART 2 PRODUCTS

2.01 CONTAINMENT

- A. 6 mil (150-micron) polyethylene sheeting or bags and appropriate tape, in accordance with ASTM D4397-16

2.02 TRANSITION COUPLINGS

- A. Refer to requirements of Section 15162.

PART 3 EXECUTION

3.01 CUTTING, REMOVAL, AND HANDLING

- A. Adequate care shall be taken to maintain the materials in a non-friable state.
- B. Pipe cutting will be permitted only when repairing or joining existing ACP, as determined by the District.
- C. All cutting of ACP shall be by snap-cut method.
- D. ACP shall be wrapped in 6 mil (150-micron) polyethylene sheeting or bags sealed with appropriate tape, and properly labeled and removed away from the construction area to prevent damage.

3.02 DISPOSAL

- A. Asbestos materials are considered hazardous materials regulated as a hazardous waste in California.
- B. The Contractor shall be responsible for the proper identification, removal and disposal of all asbestos materials.

3.03 CONNECTING TO EXISTING ACP

- A. Connect to existing ACP with a transition coupling.
- B. Provide minimum 3-foot length PVC pipe spool between the transition coupling and new valve, fitting, or piping.

END OF SECTION

SECTION 15089

AIR VALVES

PART 1 GENERAL

1.01 SECTION INCLUDES

- A. Combination air valves

1.02 RELATED REQUIREMENTS

- 1. Section 09900, Painting and Coating
- 2. Section 15042, Hydrostatic Testing of Pressure Pipelines

1.03 REFERENCED STANDARDS

- A. American Water Works Association (AWWA)
 - 1. AWWA C213: Standard for Fusion-Bonded Epoxy Coating for the Interior and Exterior of Steel Water Pipelines
 - 2. AWWA C512: Air-Release, Air/Vacuum, and Combination Air Valves for Water and Wastewater Service
- B. ASTM International
 - 1. ASTM A126: Standard Specification for Gray Iron Castings for Valves, Flanges, and Pipe Fittings
 - 2. ASTM A240: Standard Specification for Chromium and Chromium-Nickel Stainless Steel Plate, Sheet, and Strip for Pressure Vessels and for General Applications
 - 3. ASTM A276: Standard Specification for Stainless Steel Bars and Shapes
- C. NSF International
 - 1. NSF 61: Drinking Water Systems Components – Health Effects

1.04 SUBMITTALS

- A. Product data sheets
- B. Shop drawings
- C. NSF 61 conformance certification for lining (for potable water applications)

1.05 QUALITY ASSURANCE

- A. Conform to AWWA C512. Where discrepancies exist between current AWWA C512 and this specification, the more stringent requirements shall govern.

PART 2 PRODUCTS

2.01 COMBINATION AIR VALVES

- A. Description: Combination valve assemblies shall function to accomplish the following:
1. Slowly release pockets of air which accumulate at high points, or changes in line gradient.
 2. Exhaust large quantities of air from the pipeline when being filled.
 3. Admit large quantities of air into the pipeline when being drained to prevent air lock or vacuum collapse of the pipe.

B. Materials for air valves ≤ 2”:

Item	Material	Specification
Body and Cover	Reinforced Nylon	-
Float, Lever Poppet	Foamed Polypropylene	-
Screws	Stainless Steel	ANSI Type 316
Drain Plug	Reinforced Nylon	-
Discharge Outlet	Polypropylene	-

C. Materials for air valves >2”:

Item	Material	Specification
Body and Cover	Cast Iron, Ductile Iron, or 316 Stainless Steel	ASTM A126, Class B - -
Float, Lever Poppet	Stainless Steel or Foamed Polypropylene	ANSI Type 316 -
Seat	Rubber	Buna-N (Chlorine Resistant)
Drain Plug	Bronze	85-5-5-5 Alloy
Casing bolts/nuts	Stainless Steel	ANSI Type 316

- D. Interior valve lining:
1. Fusion bonded epoxy lined per AWWA C213 for valves greater than 2”.
 2. Conform to requirements of NSF 61 for potable water applications.
- E. Connections: All valves 2-inch and smaller shall have threaded inlets. All valves 3-inch and larger shall have flanged inlets.
- F. Style:
1. 4-inch diameter and smaller valves: Both air-vacuum and air-release functions shall be contained in one valve body.

2. 6-inch diameter and larger valves: Separate valves for each function piped together to function as one unit is permitted. An isolation valve shall be installed between the two units.

2.02 AIR VALVE ENCLOSURES

A. Description:

1. Low density polyethylene construction within UV inhibitors
2. 1/2-inch vent holes at approximately 4-inch on center around circumference of enclosure

B. Color:

1. Sandstone, or approved equal
2. When used on recycled water, paint vent hole strip purple per Section 09900.

C. Enclosure size:

1. 1-inch air valves: 12-inch diameter by 36-inch high enclosure
2. 2-inch air valves: 12-inch diameter (if enclosure fits) or 20-inch diameter by 36 inch high enclosure
3. 2-1/2-inch and larger air valves: 24-inch diameter by 36 inch high enclosure

PART 3 EXECUTION

3.01 INSTALLATION

- A. Install per manufacturer's recommendations.
- B. Clean threaded joints by wire brushing or swabbing. Apply Teflon joint compound or Teflon tape to pipe threads before installing threaded valves. Joints shall be watertight.

3.02 FIELD COATING

- A. Coat exterior of valve per requirements of Section 09900.

3.03 VALVE PRESSURE TESTING

- A. Test valves at the same time that the connecting pipelines are pressure tested. Refer to Section 15042.
- B. Protect or isolate any parts whose pressure rating is less than the test pressure.

END OF SECTION

SECTION 15100
MANUAL VALVES

PART 1 GENERAL

1.01 SECTION INCLUDES

- A. Bronze Ball Valves
- B. Metal Seated Gate Valves
- C. Tapping Vales
- D. Butterfly Valves
- E. Resilient-Seated Gate Valves
- F. Valve operators and appurtenances

1.02 RELATED REQUIREMENTS

- A. Section 02223, Trenching, Backfilling, and Compacting
- B. Section 09900, Painting and Coating
- C. Section 15042, Hydrostatic Testing of Pressure Pipelines
- D. Section 15056, Ductile-Iron Pipe and Fittings

1.03 REFERENCED STANDARDS

- A. American Water Works Association
 - 1. AWWA C105: Polyethylene Encasement for Ductile-Iron Pipe Systems
 - 2. AWWA C210: Liquid-Epoxy Coating Systems for the Interior and Exterior of Steel Water Pipelines
 - 3. AWWA C213: Fusion-Bonded Epoxy Coating for the Interior and Exterior of Steel Water Pipelines
 - 4. AWWA C500: Metal-Seated Gate Valves for Water Supply Service
 - 5. AWWA C504: Rubber-Seated Butterfly Valves
 - 6. AWWA C509: Resilient-Seated Gate Valves for Water Supply Service
 - 7. AWWA C510: Double Check Valve Backflow Prevention Assembly
 - 8. AWWA C515: Reduced-Wall, Resilient-Seated Gate Valves for Water Supply Service

B. ASTM International

1. ASTM A126: Standard Specification for Gray Iron Castings for Valves, Flanges, and Pipe Fittings
2. ASTM A536: Standard Specification for Ductile Iron Castings
3. ASTM B62: Standard Specification Composition Brass or Ounce Metal Castings

1.04 SUBMITTALS

- A. Product data sheets
- B. Materials
- C. Pressure rating
- D. Shop Drawings

1.05 QUALITY ASSURANCE

- A. The Contractor shall use valves from a single approved manufacturer for all valves throughout the project or development.

PART 2 PRODUCTS

2.01 GENERAL

- A. Valves shall be installed complete with operating handwheels or levers, extension stems, worm gear operators, operating nuts, and wrenches required for operation.
- B. Valves shall have the name of the manufacturer and the size of the valve cast or molded onto the valve body or bonnet or shown on a permanently attached plate.
- C. Valve body and trim casting shall be of domestic origin.

2.02 BRONZE BALL VALVES

- A. Aboveground Ball Valves 3 Inches and Smaller
 1. Aboveground threaded end ball valves, 1/4-inch through 3-inches, for water service shall be full bore port ball type having a minimum working pressure of 200 psi WOG. Valves shall have plastic coated lever operators.

2. Materials of construction shall be as described below:

<u>Component</u>	<u>Material</u>	<u>Specification</u>
Body	Bronze	ASTM B62
Ball	Bronze	ASTM B62
Seat, Seals	PTFE	
Stem	Bronze or Copper silicon	ASTM B62, B99 (Alloy 651), B584 B371 (Alloy 694)

3. Stem material shall have a minimum tensile strength of 60,000 psi and a minimum yield strength of 30,000 psi.

2.03 METAL SEATED GATE VALVES

- A. Valves shall conform to AWWA C500 and the following.
- B. Gate valves shall be designed for a working pressure of 150 psi or 250 psi as required.
- C. Valves shall be ductile iron bodied, solid bronze internal working parts, parallel faced, bottom wedging double-discs, non-rising stem opening to the left, O-Ring seals, and a 2-inch-square operating nut.
- D. Materials of construction shall be as described below:

<u>Component</u>	<u>Material</u>	<u>Specification</u>
Body, Bonnet	Cast Iron or Ductile Iron	--
Operating Nut, Stuffing Box	Bronze or Cast Iron	ASTM B62
Bonnet Bolts	Stainless Steel	Type 316
Stuffing Box Bolts	Stainless Steel	Type 316
Interior Parts, Gate	Ductile Iron	ASTM A536
O-Rings	Synthetic rubber	ASTM D2000

- E. Gate valve stems shall be of low zinc content (2-percent), having a minimum tensile strength of 70,000 psi, a yield strength of 40,000 psi, and 12-percent elongation in 2-inches. The stem is to be visibly marked so that it meets this requirement.
- F. Gate valves shall be furnished with ends as specified on plans or by the District.

2.04 TAPPING VALVES

- A. Tapping valves shall conform to all requirements for gate valves 3 inches and larger and the additional requirements listed herein.
- B. All valve ends shall be flanged. The flange on one end shall have slotted bolt holes to fit all standard tapping machines.
- C. Seat rings shall be oversized to permit the use of full-size cutters.
- D. Resilient wedge valves may be used as tapping valves, provided that the disk fully retracts to produce a full port opening.

2.05 BUTTERFLY VALVES

- A. Butterfly valves shall be short body, conforming to AWWA C504, Class 150. Minimum working differential pressure across the valve disc shall be 150 psi unless specified otherwise on the plans.
- B. Butterfly valves shall be furnished and installed with the type of ends as shown on the plans and as herein specified. Flanged ends shall be Class 125, ANSI B16.1.
- C. Wafer style valves will not be permitted.
- D. Each valve body shall be tested under a test pressure equal to twice its design water working pressure.
- E. Valves shall be bubble tight at rated pressures and shall be satisfactory for throttling service and frequent operation after long periods of inactivity. Valve discs shall rotate 90 degrees from the full-open position to the tight-shut position.
- F. Valve shafts shall be Type 316 stainless steel. Valve shafts shall be dual stub shafts or a one-piece shaft extending completely through the valve disc.
- G. Materials of construction shall be as described below:

<u>Component</u>	<u>Material</u>	<u>Specification</u>
Body	Cast Iron or Ductile Iron	
Exposed Body Capscrews, and Bolts and Nuts	Stainless Steel	Type 316
Discs	Cast Iron Ductile Iron, or Ni-Resist	

- H. The rubber seat shall be an integral part of the valve body. Rubber seats fastened to the disc by any means shall not be permitted.

2.06 RESILIENT-SEATED WEDGE GATE VALVES

- A. Valves shall conform to AWWA C509 or AWWA C515 and the requirements listed herein.
- B. All valves shall be bubble tight at 200 psi working pressure.
- C. Valves shall have non-rising low zinc stems, opening by turning left and provided with a 2-inch-square operating nut. Outside stem and yolk valves shall be used on backflow device shutoff valves.
- D. Each valve shall have a smooth unobstructed waterway free from any sediment pockets.
- E. Stuffing boxes shall be O-ring seal type with two rings located in stem.
- F. Low friction torque reduction thrust bearings shall be located both above and below the stem collar.
- G. Materials shall be as described below:

<u>Component</u>	<u>Material</u>	<u>Specification</u>
Body, Operating Nut Bonnet, Seal Plate	Cast Iron or Ductile Iron	ASTM A126 Class B
Gate	Cast Iron or Ductile Iron	
Bonnet and Seal Bolts	Stainless Steel	Type 316
O-Rings	Synthetic Rubber	ASTM D2000

- H. All internal working parts (excluding gate) shall be all bronze containing not more than 2-percent aluminum or more than 7-percent zinc. Valve stems shall be cast or forged from bronze having a tensile strength of not less than 60,000 psi, a yield point of not less than 30,000 psi, and an elongation of not less than 10-percent in 2-inches.
- I. All gates shall be EPDM encapsulated.

2.07 BOLTS AND NUTS FOR FLANGED VALVES

- A. Bolts and nuts for flanged valves shall be Type 316 stainless steel in accordance with Section 15056.

2.08 GASKETS

- A. Gaskets for flanged end valves shall be as described in Section 15056.

2.09 VALVE OPERATORS

- A. Provide lever or wrench operators having adjustable, "position indicator" for exposed valves smaller than 6 inches.
- B. Provide 2-inch AWWA operating nuts for buried and submerged valves.
- C. Provide gear operators on butterfly valves 6-inches and larger. Gear operators for valves 8-inches through 20-inches shall be of the worm and gear, or of the traveling nut type. Gear operations for valves 24-inches and larger shall be of the worm and gear type.
- D. Gear operators shall be enclosed, suitable for running in oil with seals provided on shafts to prevent entry of dirt and water into the operator. Gear operators for valves located above ground or in vaults and structures shall have handwheels. Minimum handwheel diameter shall be 12 inches. The operator shall contain a dial indicating the position of the valve disc or plug. Gear operators for buried or submerged valves shall have 2-inch square AWWA operating nuts.
- E. For buried or submerged service, provide watertight shaft seals and watertight valve and actuator cover gaskets.
- F. Provide totally enclosed operators designed for buried or submerged service.
- G. Traveling nut and worm and gear operators shall be of the totally enclosed design so proportioned as to permit operation of the valve under full operating head with a maximum pull of 80 pounds on the handwheel or crank. Provide stop limiting devices in the operators in the open and closed positions. Operators shall be of the self-locking type to prevent the disc or plug from creeping. Design operator components between the input and the stop-limiting devices to withstand without damage a pull of 200 pounds for handwheel or chainwheel operators and an input torque of 300 foot-pounds for operating nuts when operating against the stops.
- H. Operators on buried valves shall produce the required torque on the operating nut with a maximum input of 150 foot-pounds.
- I. Valve operators, handwheels, or levers shall open by turning counterclockwise.

2.10 VALVE BOXES FOR BURIED VALVES

- A. Valve extension pipe material shall be 8-inch SDR 35 PVC pipe.
- B. Design cast iron valve box cover to rest within a frame on a cast-in-place concrete ring surrounding the valve extension pipe; size the tapered skirt of the cover for a close fit inside the upper sleeve portion of the valve box. Valve box covers for the potable water system shall be circular with the word "WATER" cast on the cover. Valve box covers for the recycled water system shall be circular with the word "RECYCLED" cast on the cover.

2.11 EXTENSION STEMS FOR BURIED VALVE OPERATORS

- A. Where the depth of the valve nut exceeds 96-inches, provide operating extension stems to bring the operating nut to a point 24-inches to 30-inches below the surface of the ground and/or box cover.

- B. Extension stems shall be steel and shall be complete with 2-inch-square operating nut.
- C. Valve stem extensions shall be of a solid design (no pinned couplings permitted) with guides.

2.12 FACTORY FINISHES

- A. Coat all ferrous surfaces.
 - 1. Interior and buried exterior surfaces:
 - a. Fusion bonded epoxy meeting requirements of AWWA C213
 - b. Liquid-epoxy meeting requirements of AWWA C210 allowed for touch up and when valve design uses bonded rubber seats
 - c. Conform to requirements of NSF 61 for interior coatings.
 - 2. Non-buried exterior surfaces: factory primer

PART 3 EXECUTION

3.01 JOINTS

- A. Bolt holes of flanged valves shall straddle the horizontal and vertical centerlines of the pipe run to which the valves are attached. Clean flanges by wire brushing before installing flanged valves. Clean flange bolts and nuts by wire brushing, lubricate threads with oil and graphite, and tighten nuts uniformly and progressively. If flanges leak under pressure testing, loosen or remove the nuts and bolts, reseal or replace the gasket, reinstall or retighten the bolts and nuts, and retest the joints. Joints shall be watertight.
- B. Clean threaded joints by wire brushing or swabbing. Apply Teflon joint compound or Teflon tape to pipe threads before installing threaded valves. Joints shall be watertight.
- C. Rubber ring grooves of valves shall be inspected before installation by the Contractor for ridges or holes that would interfere with the rubber ring. Interferences with the rubber ring shall be corrected to a satisfactory connection or the valves replaced, as required by the District. All valves shall have the same rubber-ring groove profile as the groove of the pipe couplings furnished with the pipe.

3.02 BUTTERFLY VALVE OPERATORS

- A. Butterfly valves shall be installed with the operators on the street centerline side of the pipeline.

3.03 EXTERIOR PROTECTION

- A. Valve Exterior Surface, Buried Service: Wrap buried valves with 8-mil polyethylene wrap per AWWA C105. Wrap beyond valve by 12 inches on both sides.
- B. Valve Exterior Surface, Above Grade or in Vault: Apply coatings per Section 09900. Coat all valve metal surfaces, except bronze and stainless steel surfaces.

- C. Stainless Steel Bolts and Nuts, buried service: Apply cosmoline grease corrosion guard per Section 15056 to all stainless steel bolts and nuts.

3.04 CONCRETE SUPPORTS

- A. Inline valves shall be anchored in concrete.
- B. Concrete supports will not be required under valves bolted to flanged fittings.
- C. Until supports are poured, valves shall be temporarily supported by placing wooden skids underneath the valve so that the pipe is not subjected to the weight of the valve.
- D. All concrete anchors and thrust blocks specified or required by the District are considered as part of the pipeline installation.

3.05 VALVE BOXES

- A. Valve boxes shall be firmly supported and shall be kept centered and plumb over the operating nut of the valve.
- B. Beveled sections of pipe will not be allowed at the top of the valve extension pipe. The top cut shall be square and machine made.
- C. During the construction of new tracts, the valve extension pipes for "key valves" identified by the District shall extend well above the ground level to permit ease of location in case of emergency shutoffs.
- D. The box cover shall be flush with the surface of the finished pavement or at any other level designated by the District.

3.06 BACKFILL

- A. All backfill within 24-inches of a valve shall be clean, washed sand.
- B. Backfill is to be placed and compacted in accordance with Section 02223.

3.07 VALVE LEAKAGE TESTING

- A. Test valves for leakage at the same time that the connecting pipelines are tested. See Section 15042 for pressure testing requirements.
- B. Valves shall have a pressure rating higher than or equal to the test pressure.
- C. All valves 16-inch and larger shall be hydrostatically shop tested to the valves working pressure in the presence of the District inspector. Each side of the valve shall be tested independently. Exterior epoxy shall be touched up as required. After testing, valves shall be palletized, shrink wrapped, and delivered to the job site.

3.08 VALVE LOCATION

- A. The location of all valves shall be marked with a 2-inch “V” chiseled in the curb face perpendicular to the valve. The offset distance, in feet, from the curb face to the valve shall be chiseled next to the “V”. Where a perpendicular offset is not possible, multiple tangential offsets will be required to allow triangulation of the valve location.

END OF SECTION

SECTION 15112

BACKFLOW PREVENTERS

PART 1 GENERAL

1.01 SECTION INCLUDES

- A. Backflow prevention assemblies

1.02 RELATED REQUIREMENTS

- A. Section 15056, Ductile-Iron Pipe and Fittings
- B. Section 15057, Copper, Brass and Bronze Pipe Fittings and Appurtenances
- C. Section 15100, Manual Valves
- D. Section 15150, Meters

1.03 REFERENCED STANDARDS

- A. Foundation for Cross-Connection Control and Hydraulic Research, University of Southern California, School of Engineering
 - 1. "Manual of Cross-Connection Control"
- B. American Water Works Association (AWWA)
 - 1. AWWA C510: Double Check Valve Backflow Prevention Assembly
 - 2. AWWA C511: Reduced-Pressure Principle Backflow Prevention Assembly

1.04 SUBMITTALS

- A. Product Data Sheet and Drawings
- B. Certification of approved assembly per the California State Water Resources Control Board
- C. Field testing certificate

PART 2 MATERIALS

2.01 BACKFLOW PREVENTION ASSEMBLY

- A. All backflow prevention assemblies shall conform to the latest edition of AWWA C510 or C511.
- B. Backflow prevention assemblies shall be on the latest approved list of backflow prevention assemblies from the U.S.C./F.C.C.C. & H.R. Institute and comply with the California State Water Resources Control Board.

- C. Backflow assemblies for Moulton Niguel Water District-owned or maintained backflows shall be as follows, no exceptions:
 - 1. 3/4-inch – 2-inch Febco RP #LF825Y (For domestic potable water or potable water used for irrigation)
 - 2. 2-1/2-inch – 10-inch Zurn/Wilkins RP #375AST (For domestic potable water or potable water used for irrigation)
 - 3. 2-1/2-inch – 10-inch Zurn/Wilkins DCDA #350ASTDA (For fire protection water)"

2.02 SHUT-OFF VALVES

- A. The shut-off valves for assemblies 2 1/2-inch and larger shall be resilient seat gate valves. Ball valves shall be used on assemblies smaller than 2 1/2-inch. Shut-off valves shall conform to Section 15100.
- B. Shut-off valves shall have outside stems and yokes for fire protection water and non-rising stems for domestic or potable water used for irrigation.

2.03 FIRE SERVICE BYPASS PIPING

- A. Bypass piping shall be copper or brass conforming to Section 15057.

2.04 FIRE SERVICE BYPASS METER

- A. The bypass meter shall conform to the requirements of Section 15150 and shall be compatible with the backflow assembly on which it is installed. The backflow prevention assembly and the bypass meter shall be furnished as one complete unit. All bypass meters shall be 3/4-inch, with registers reading in cubic feet.

PART 3 EXECUTION

3.01 INSTALLATION

- A. Installation shall comply with the requirements of the latest edition of the California Cross Connection Control Policy Handbook

3.02 TESTING

- A. Upon completion of the installation of the assembly, a test shall be performed and a certificate of the adequacy and operational compliance shall be furnished to the District. The tests shall be performed by a testing agency approved by the Orange County Health Department.

END OF SECTION

SECTION 15139

FIRE HYDRANTS

PART 1 GENERAL

1.01 SECTION INCLUDES

- A. Wet barrel fire hydrants

1.02 RELATED REQUIREMENTS

- A. Section 02223, Trenching, Backfilling, and Compacting
- B. Section 09900, Painting and Coating
- C. Section 15042, Hydrostatic Testing of Pressure Pipelines
- D. Section 15056, Ductile-Iron Pipe and Fittings

1.03 REFERENCED STANDARDS

- A. ASTM B62: Standard Specification for Composition Bronze or Ounce Metal Castings
- B. AWWA C503: Wet-Barrel Fire Hydrants
- C. AWWA M17: Fire Hydrants: Installation, Field Testing, and Maintenance

1.04 SUBMITTALS

- A. Product data sheets
- B. Shop drawings

PART 2 PRODUCTS

2.01 WET BARREL HYDRANT

- A. General: Conform to AWWA C503.
- B. Hydrant Top Section
 1. Fire hydrants shall have individual valves for each outlet opening counter clockwise. Fire hydrants for residential use shall have one 2-1/2 inch hose nozzle and one 4-inch pumper nozzle. Fire hydrants for commercial or industrial developments shall have one (1) 2-1/2 inch hose nozzle and two (2) 4-inch pumper nozzles.
 2. All outlets shall have National Standard Hose Threads.
 3. The hydrant top section shall be manufactured of bronze conforming to ASTM B62.

4. All interior working parts, including stems, shall be of bronze containing no more than 7-percent zinc or 2-percent aluminum.
5. Hydrants are to be provided with:
 - a. 1-1/2-inch sized pentagon-shaped operating nut, and
 - b. 1-1/2-inch capnuts
6. All fire hydrants shall have the name of the manufacturer cast onto the hydrant body or shown on a permanently attached plate.
7. Plastic outlet nozzle caps shall be provided for all outlets. Caps shall be securely chained to the barrel with non-kinking metal chain in a manner to permit free rotation of the cap.
8. All hydrant flanges shall be eight-hole regular, Class 125, American Standard cast iron flange drilling.

C. Bury Section

1. The bury section shall be 6-inch (cast-iron or ductile-iron) long radius bury elbow and shall be cement lined in conformance with Section 15056. Bury inlet shall be 6-inch rubber-ring hub bell connection for C900 PVC pressure pipe.
2. A flanged ductile iron spool shall be installed to position the hydrant flange 4 inches above the concrete pad (finish grade).
3. All wet-barrel fire hydrant cast-iron and ductile-iron buries are to be cement lined.
4. When using a riser spool, bolts shall be Type 316 stainless steel, standard non break-away.
5. Bury section outlet and riser spool flanges shall be eight-hole regular, Class 125, American Standard cast-iron flange drilling.

D. Break-Off Check Valve

1. DI Body
2. 250 psi rating
3. Retrofit existing concrete pad as required to install on existing hydrant
4. Use 316 SS bolts for break-off valve application

2.02 BREAK-AWAY BOLTS

- A. Unless otherwise specified, break-away bolts shall not be used to join the spool section to the hydrant top section.
- B. All bolts, and nuts, shall be Type 316 stainless steel.

2.03 GASKETS

- A. Gaskets shall be of rubber composition per Section 15056.

PART 3 EXECUTION

3.01 GENERAL

- A. Fire hydrant assemblies shall be installed in accordance with the standard drawing and as specified herein, and shall include the connection to the main, the fire hydrant, hydrant bury, shutoff valve, valve well and valve box, connection piping, concrete thrust blocks, and appurtenances.
- B. Conform to AWWA M17.

3.02 TRENCHING, BACKFILLING, AND COMPACTING

- A. All trenching, backfilling, compaction, and other excavation shall be in accordance with Section 02223.
- B. All backfill within 24 inches of a valve shall be imported sand.

3.03 BREAK-AWAY BOLTS

- A. Break-away bolts shall be installed with the threads away from the top of the hydrant.

3.04 FIELD COATING

- A. All public fire hydrants shall be painted in accordance with Section 09900.

3.05 TESTING

- A. Test hydrants at the same time that the connecting pipeline is pressure tested. See Section 15042 for pressure testing requirements.

END OF SECTION

SECTION 15150

METERS

PART 1 GENERAL

1.01 SECTION INCLUDES

- A. Customer Meters and Fire Service Bypass Meters (3/4-inch through 1-inch)
- B. Customer Meter (1-1/2 inch through 2 inch)
- C. Commercial and Irrigation Customer Meters (3-inch through 8-inch) and Commercial Bypass Meters (2-inch)
- D. Propeller Flowmeters
- E. Magnetic Flowmeters

1.02 RELATED REQUIREMENTS

- A. Section 15042, Hydrostatic Testing of Pressure Pipelines

1.03 REFERENCED STANDARDS

- A. American Water Works Association
 - 1. AWWA C700: Cold-Water Meters -- Displacement Type, Metal Alloy Main Case
 - 2. AWWA C701: Cold-Water Meters -- Turbine Type, for Customer Service
 - 3. AWWA C702: Cold-Water Meters -- Compound Type
 - 4. AWWA C703: Cold-Water Meters -- Fire Service Type
 - 5. AWWA C704: Propeller-Type Meters for Waterworks Applications
 - 6. AWWA C710: Cold-Water Meters -- Displacement Type, Plastic Main Case
 - 7. AWWA C751: Magnetic Inductive Flowmeters
 - 8. AWWA M6: Water Meters--Selection, Installation, Testing and Maintenance
- B. ASTM International
 - 1. ASTM A193: Standard Specification for Alloy-Steel and Stainless Steel Bolting for High Temperature or High Pressure Service and Other Special Purpose Applications
 - 2. ASTM A194: Standard Specification for Carbon Steel, Alloy Steel, and Stainless Steel Nuts for Bolts for High Pressure or High Temperature Service, or Both

1.04 COORDINATION

- A. All residential meters 3/4-inch through 2-inch will be furnished by the District, subsequent to payment of all applicable charges, and installed by the Applicant.

- B. All industrial, commercial, individual service meters 3-inch and larger will be supplied and installed by the Applicant and dedicated to the District subsequent to payment of applicable charges.
- C. Prepayment of meters and appurtenances is not allowed. Upon payment of fees for meter and appurtenances, the entire meter package must be collected at that time. The District will not store meters and appurtenances after payment of charges. The meter package consists of meter box, gaskets, tailpieces, shut-offs, meter, and all other appurtenant facilities. The Applicant will be charged for the specified minimum billing per billing period for all tailpieces and shut-offs, regardless of whether or not the meter was used.
- D. Subsequent applications for permanent service shall be made in accordance with the District's Rules and Regulations.

1.05 SUBMITTALS

- A. Product data sheets and drawings

PART 2 PRODUCTS

2.01 CUSTOMER METERS AND FIRE SERVICE BYPASS METERS (3/4-INCH THROUGH 1-INCH)

- A. Meter shall be electromagnetic type.
- B. Meter body and flow tube shall be constructed of composite alloys and contain no metal material. Coated silver electrodes embedded in the flowtube shall be used to measure flow velocity.
- C. The register shall be hermetically sealed with a nine digit programmable electronic register and LCD display. The meter shall be compatible with common AMR/AMI systems. The register shall be Sensus protocol and include a touch read device.
- D. 3/4-inch meters shall be rated at 200 psi maximum operating pressure and 1-inch meters shall be rated at 175 psi maximum operating pressure.
- E. The manufacturer shall furnish certified results for each meter showing that it has been tested for accuracy of registration and pressure loss requirements with respect to the accuracy and capacity requirements of AWWA C700 and AWWA C710 when tested in accordance with AWWA Manual M6.
- F. Meters shall be NSF/ANSI Standard 61 Annex F and G compliant.
- G. Meter shall be provided with threaded end connections.
- H. All registers shall be of integrated tamper-proof construction with magnetic tamper and low field alarms. Safety wiring of standard bolts and screws is NOT considered an acceptable method of tamper-proofing.
- I. The serial number of each meter shall be imprinted on the register.

- J. Meters shall be supplied with the following warranty, which shall not be prorated under any conditions:
 - 1. All meters shall be guaranteed to maintain new-meter accuracy (+/- 1.5-percent) for twenty years.
 - 2. All meters shall have a twenty year battery life guarantee.
- K. Meters shall be guaranteed to maintain a low flow accuracy of +/- 3-percent over the following ranges

Meter size (inches)	Low Flow Range with +/- 3-percent Accuracy	Starting Flow
3/4	>.11 gpm to <0.18 gpm	0.03 gpm
1	>.3 gpm to <0.4 gpm	0.11 gpm

2.02 CUSTOMER METER (1-1/2-INCH THROUGH 2-INCH)

- A. Meter housing shall be constructed of polyphenylene sulfide (PPS) mounted in a stainless steel body. Volume shall be measured using a bidirectional ultrasonic technique based on the transit time method. The meter shall have no moving parts.
- B. Meter shall be IP68 (submersible) type suitable for installation in meter pits.
- C. The register shall be hermetically sealed with a nine digit programmable electronic register and LCD display. The meter shall be compatible with common AMR/AMI systems. Consumption data may be read visually from the display, with an optical eye, and remotely, either with a built in 915 MHz band RF signal or by a three wire encoded interface. The register shall be Sensus protocol and include a touch read device.
- D. Meters shall be rated at 300 psi maximum operating pressure.
- E. The manufacturer shall furnish certified results for each meter showing that it has been tested for accuracy of registration and pressure loss requirements with respect to the accuracy and capacity requirements of AWWA C700 and AWWA C710 when tested in accordance with AWWA Manual M6.
- F. Meters shall be NSF/ANSI Standard 61 compliant.
- G. Meter shall be provided with flanged end connections.

- H. Meters shall be guaranteed to maintain a low flow accuracy of +/- 3-percent over the following ranges

Meter size (inches)	Leak Flow Detection	Extended Low Flow Range	Max. Flow for continuous operation
1-1/2	0.06 gpm	0.4 – 1.2 gpm	120 gpm
2	0.1 gpm	0.5 – 1.5 gpm	160 gpm

2.03 COMMERCIAL AND IRRIGATION CUSTOMER METERS (3-INCH THROUGH 8-INCH) AND COMMERCIAL BYPASS METERS (2-INCH)

- A. Provide turbine meters in conformance with AWWA C701 and AWWA C702 Class II and the requirements specified herein. Turbine meters used for fire service shall comply with AWWA C703.
- B. The manufacturer shall furnish certified test results for each meter showing that it has been tested for accuracy of registration and that it complies with accuracy and capacity requirements of AWWA C701 and AWWA C702 Class II when tested in accordance with AWWA Manual M6.
- C. Meters shall have ductile iron main cases with a fusion bonded epoxy NSF approved lining and coating. Main case for turbine meters 3” in size shall be 304 stainless steel. Meter assemblies shall be provided with ANSI Class 125 flat faced flanges conforming to ANSI B16.1. Turbine meters shall be rated for a maximum operating pressure of 200 psi.
- D. Meters shall be NSF/ANSI Standard 61 Annex F and G compliant.
- E. Measuring chamber assembly shall utilize “floating ball” impeller with a coated titanium shaft, hybrid thermoplastic radial bearings, and sapphire/ceramic thrust bearings.
- F. Fully electronic hermetically sealed register with electronic pickup containing no moving parts and programmable registration. The electronic register shall at a minimum include AMR resolution units fully programmable, large easy to read LED display, integral data logging capability, and pulsed output frequency fully programmable. The register shall be Sensus protocol and include a touch read device.
- G. Meters shall be equipped with strainers. All strainers shall be furnished with stainless steel screens with an effective open area at least double the area of the meter. On metered fire service installations, a U.L/FM. approved strainer is required.
- H. The serial number of each meter shall be imprinted on the register cover and the main case.

2.04 PROPELLER METERS

- A. All propeller meters shall conform to AWWA C704 and the requirements specified herein.
- B. The meter tubing shall be fabricated steel with straightening vanes and provided with fusion bonded epoxy NSF approved coating and lining. Tube shall be constructed with 150 lb. AWWA Class D flat face flanged ends.
- C. Meter head shall be mounted on a flanged connection for easy removal of all interior parts from the pipe tee without disturbing the connections to the pipeline.
- D. Bearing in propeller shall be a water lubricated ceramic sleeve and spindle bearing system with a ceramic/stainless steel spindle. Provide dual ceramic thrust bearings to handle flows in both forward and reverse directions.
- E. Bearings within the sealed meter mechanism shall be shielded precision stainless steel bearings, factory lubricated for the life of the meter.
- F. All meters shall be provided with injection molded thermoplastic propellers.
- G. Stainless steel gear boxes on the propeller drive shafts are required.

2.05 MAGNETIC FLOWMETER

- A. All magnetic flowmeters shall conform to AWWA C751 and the requirements specified herein.
- B. Mounting style shall be ASME B16.5 Class 150 or Class 300 flanges and shall be equivalent to adjacent flanges,
- C. Flowmeter will be designed for IP68 and NEMA 6P submersible construction.
- D. Case and flanges shall be mild steel coated with a polyurethane resin. Liner shall be NSF 61 certified. Electrodes shall be compatible with and recommended for use with NSF 61 liner.
- E. Converter shall be combined or separate dependent on District acceptance. Converter shall be equipped with a LED readout and, at a minimum, provide instantaneous flowrate and totalizer readings.

2.06 HARDWARE

- A. All bolts, nuts, cap screws, studs, and washers shall be Type 316 stainless steel ASTM A193 B8M for bolts, and ASTM A194 8M for nuts.

PART 3 EXECUTION

3.01 BYPASS VALVES

- A. Provide lockable valves (in the closed position) on all bypass lines. On 3-inch and larger bypass lines, resilient seat gate valves with hand wheels and a chain and lock are permitted.

3.02 TEST TAP

- A. On services 3 inches and larger, a 2-inch nipple with ball valve service saddle or welded coupling and corporation stop shall be installed on the spool downstream of the meter. The tap shall be located a minimum of three (3) pipe diameters downstream of the meter. On propeller meter installations, the location of the test tap will be determined by the District.

3.03 TESTING

- A. All meter services shall be hydrostatically pressure tested during the testing of pipeline in accordance with Section 15042.

END OF SECTION

SECTION 15151

**POTABLE WATER, RECYCLED WATER, AND WASTEWATER FACILITIES
IDENTIFICATION**

PART 1 GENERAL

1.01 SECTION INCLUDES

- A. Warning Tape
- B. Warning Labels
- C. Witness Markers
- D. Stenciling

1.02 RELATED REQUIREMENTS

- A. Section 09900, Painting and Coating
- B. Section 15100, Manual Valves
- C. Section 15139, Fire Hydrants

1.03 SUBMITTALS

- A. Product data sheets

PART 2 PRODUCTS

2.01 WARNING TAPE FOR BURIED PIPE

- A. The plastic warning tape shall be an inert plastic film specifically formulated for prolonged underground use.
- B. The minimum thickness shall be 4 mils.
- C. Overall width of the tape shall be 12 inches (for 8-inch and larger pipe) and 6 inches (for 6-inch and smaller pipe).
- D. Lettering:
 - 1. Potable Water: Blue background with the following words in black letters: "CAUTION: POTABLE WATER-LINE BURIED BELOW"
 - 2. Recycled Water: Purple background with the following words in black letters: "CAUTION: RECYCLED WATER-LINE BURIED BELOW"

3. Sewer: Green background with the following words in black letters: "CAUTION: SEWER-LINE BURIED BELOW"

2.02 WARNING LABELS FOR EXPOSED PIPE AND APPURTENANCES

- A. Labels shall be inert plastic film specifically formulated for prolonged exposure.
- B. The minimum thickness shall be 4 mils for adhesive backed labels and 10 mils for tag type labels.
- C. Tag type labels shall have reinforced tie holes and shall be attached with heavy-duty nylon fasteners.
- D. Provide with 1/2-inch high black letters (minimum):
 1. Potable Water: Blue background with the following words in black letters: "POTABLE WATER"
 2. Recycled Water: Purple background with the following words in black letters: "CAUTION: RECYCLED WATER – DO NOT DRINK"
- E. The size and type of label will be dictated by each individual application and subject to acceptance by the District.

2.03 WITNESS MARKERS

- A. Design:
 1. High visibility
 2. Equipped with a barb or other such device to secure marker in the surrounding soil
- B. Materials: UV-resistant fiberglass
- C. Identification:
 1. Potable Water: Blue background with the following words in black letters: "POTABLE WATER"
 2. Recycled Water: Purple background with the following words in black letters: "RECYCLED WATER"
 3. Sewer: Green background with the following words in black letters: "SEWER"

PART 3 EXECUTION

3.01 INSTALLATION OF PIPE WARNING TAPE

- A. Install warning tapes 12-inches above all pipe.
 1. Longitudinally center over pipe.
 2. Install warning tape continuously for the length of the pipe.

3.02 INSTALLATION OF WARNING LABELS

- A. Install warning labels on all appurtenances in vaults, such as, but not limited to, air release valves, blow offs, and meters, and on designated facilities, such as, but not limited to, controller panels, wash down or blow off hydrants, on water trucks, and temporary construction services.
- B. Location of labels will be dictated by each individual application and subject to acceptance by the District.
- C. Firmly attach warning labels to all appurtenances using heavy-duty nylon fasteners.
- D. Painted labels may, at the District discretion be acceptable in lieu of plastic labels.

3.03 INSTALLATION OF WITNESS MARKERS (UNPAVED AREAS)

- A. Install witness markers over all pipe in unpaved areas and open space areas at intervals not greater than 200 feet.
- B. Install witness markers at all appurtenances, including but not limited to valves, valve boxes, air release/vacuum breaks, dead ends, inflection points, and tees.
- C. Witness markers shall be embedded into the soil at least 18-inches or as directed by manufacturer; the more stringent requirement shall apply.

3.04 COLOR AND STENCILING OF POLYETHYLENE ENCASEMENT SLEEVES

- A. Ductile iron pipe carrying recycled water: Pantone 512C purple 8-mil polyethylene sleeve with the words "RECYCLED WATER" stenciled with 2-inch black letters.
- B. Service lines
 - 1. Potable water: Blue 8-mil polyethylene sleeve
 - 2. Recycled water: Pantone 512C purple 8-mil polyethylene sleeve.

3.05 STENCILING

- A. Stencil all pipe as follows:
 - 1. PVC or ductile iron pipe carrying potable water, and located in the vicinity of recycled water piping:
 - a. Stencil the words "POTABLE WATER" with 2-inch black letters.
 - b. Lettering shall be on both sides of the pipe in at least three places in a 18-foot section of pipe (total six places per section of pipe).
 - 2. PVC or ductile iron pipe carrying recycled water:
 - a. Stencil the words "CAUTION: RECYCLED WATER – DO NOT DRINK" in 5/8-inch letters.
 - b. Lettering shall appear on both sides of the pipe repeated every 12 inches.

3.06 COLOR OF BURIED PVC PIPE

- A. Potable water: Blue
- B. Recycled Water: Pantone 522C Purple
- C. Sewer: Green

3.07 VALVE AND METER BOXES

- A. All valve and meter boxes for recycled water facilities shall have covers with the inscription "RECYCLED" cast thereon.
- B. Valve box lids for recycled water shall be painted purple per requirements of Section 09900.
- C. Steel meter box lids for recycled water shall be painted purple per requirements of Section 09900.
- D. Polymer meter box lids shall be tinted purple.

3.08 RESTRICTION OF PUBLIC ACCESS

- A. All off-site recycled water facilities shall be restricted from public access so that the general public cannot draw water from the system. Facilities such as air release assemblies, blow-off hydrants, blow offs on strainers, and other such facilities, shall be restricted from public access.
- B. Recycled water facilities, both above and below grade, shall be housed in an approved lockable container colored purple. A sign reading "CAUTION: RECYCLED WATER" shall be installed, its size accepted by the District. Other means of restricting public access may be accepted by the District.

END OF SECTION

SECTION 15162

PIPE COUPLINGS AND ADAPTERS

PART 1 GENERAL

1.01 SECTION INCLUDES

- A. Sleeve-Type Couplings
- B. Restrained Sleeve-Type Couplings
- C. Restrained One-Piece Coupling

1.02 RELATED REQUIREMENTS

- A. Section 09900, Painting and Coating
- B. Section 15042, Hydrostatic Testing of Pressure Pipelines

1.03 DEFINITIONS

- A. Straight coupling: A coupling that uses end rings of the same size and a center sleeve with ends of proper inside diameters to join pipes of the same outside diameters
- B. Reducer coupling: A coupling that uses end rings of different sizes and a center sleeve with ends of proper inside diameters to join pipes of different outside diameters
- C. Transition coupling: A coupling used to join pipe of the same nominal size, but of differing outside diameters. Differences in pipe outside diameters are accommodated by specially sized gaskets and, when necessary, specially sized end rings.
- D. Flange coupling adapters: A coupling used to connect plain-end pipe to a flange. It consists of a flange, center sleeve, gasket, and an end ring connected with bolts and nuts.

1.04 REFERENCED STANDARDS

- A. American Water Works Association
 - 1. AWWA C105: Polyethylene Encasement for Ductile-Iron Pipe Systems
 - 2. AWWA C111: Rubber-Gasket Joints for Ductile-Iron Pressure Pipe and Fittings
 - 3. AWWA C213: Fusion-Bonded Epoxy Coating for the Interior and Exterior of Steel Water Pipelines
 - 4. AWWA C219: Bolted, Sleeve-Type Couplings for Plain-End Pipe
 - 5. AWWA M11: Steel Pipe: A Guide for Design and Installation

B. ASTM International

1. ASTM A36: Standard Specification for Carbon Structural Steel
2. ASTM A193: Standard Specification for Alloy-Steel and Stainless Steel Bolting for High Temperature or High Pressure Service and Other Special Purpose Applications
3. ASTM A194: Standard Specification for Carbon Steel, Alloy Steel, and Stainless Steel Nuts for Bolts for High Pressure or High Temperature Service, or Both
4. ASTM A283: Standard Specification for Low and Intermediate Tensile Strength Carbon Steel Plates
5. ASTM A285: Standard Specification for Pressure Vessel Plates, Carbon Steel, Low- and Intermediate-Tensile Strength
6. ASTM A536: Standard Specification for Ductile Iron Castings
7. ASTM A576: Standard Specification for Steel Bars, Carbon, Hot-Wrought, Special Quality

C. NSF International (NSF)

1. NSF 61: Drinking Water System Components – Health Effects

1.05 SUBMITTALS

A. Product data sheets

1. Materials
2. Pipe material and outside diameter dimensions suitable for coupling
3. Pressure rating

B. Shop drawings

PART 2 PRODUCTS

2.01 SLEEVE-TYPE COUPLINGS

A. Design:

1. Comply with AWWA C219
2. Assembly consisting of a center sleeve, gaskets, and end rings connected with bolts and nuts. Tightening of the fasteners transfers the load through the end rings and compresses the gaskets into the space between the inside of the center sleeve and the outside surface of the pipe ends.
3. Types: Straight couplings, reducing couplings, transition couplings, and flange coupling adapters

B. Pressure rating: Greater than or equal to the pressure rating of adjacent piping

C. Materials:

1. Center rings/sleeve: Ductile iron per ASTM A536, grade 65-45-12 or carbon steel per ASTM A283, grade C
2. End Rings/followers: Ductile iron per ASTM A536, grade 65-45-12 or carbon steel per ASTM A576, grade 1020
3. Gaskets: Styrene-butadiene (SBR)
4. Sleeve Bolts: Type 316 stainless steel per ASTM A-193 (Grade B8M)
5. Nuts: Type 316 stainless steel per ASTM A-194 (Grade B8M)

2.02 RESTRAINED SLEEVE-TYPE COUPLINGS

A. General:

1. Comply with AWWA C219
2. Sleeve-type coupling with restraining end rings/followers consisting of multiple gripping lugs/wedges/pads around the pipe circumference
 - a. Specifically designed for the pipe material being connected to coupling
 - b. Proper actuation of the gripping lugs/wedges/pads achieved through use of torque limiting twist off nuts
3. Types: Straight couplings, reducing couplings, transition couplings, and flange coupling adapters

B. Pressure rating: Greater than or equal to the pressure rating of adjacent piping

C. Materials:

1. Center rings/sleeve: Ductile iron per ASTM A536, grade 65-45-12 or carbon steel per ASTM A283, grade C
2. End Rings/followers: Ductile iron per ASTM A536, grade 65-45-12 or carbon steel per ASTM A576, grade 1020
3. Gaskets: Styrene-butadiene (SBR)
4. Sleeve Bolts: Type 316 stainless steel per ASTM A-193 (Grade B8M)
5. Nuts: Type 316 stainless steel per ASTM A-194 (Grade B8M)
6. Restraining lugs/wedges/pads: Heat treated ductile iron

2.03 RESTRAINED ONE-PIECE COUPLING

A. General:

1. One-piece coupling with one bolt and nut per end and no loose components. When tightened, coupling shall simultaneously seal and restrain pipe end using rotating end rings, draw hook fasteners, and individual grippers. Individual grippers compensate for angular deflection and distribute load evenly around pipe circumference.
 - a. Specifically designed for the pipe material being connected to coupling
2. Types: Straight couplings and flange coupling adapters

- B. Pressure rating: Greater than or equal to the pressure rating of adjacent piping
- C. Materials:
 - 1. Center rings, end rings, and bolt guides: Ductile iron per ASTM A536, grade 65-45-12
 - 2. Grippers: Ductile iron per ASTM A536, grade 65-45-12, machine sharpened, heat treated, Xylan 1424 coated
 - 3. Gaskets: Styrene-butadiene (SBR)
 - 4. Draw hook fasteners: Type 304L stainless steel
 - 5. Bolts and nuts: Type 316 stainless steel

2.04 FACTORY FINISHES

- A. Coat all interior and exterior ferrous surfaces as follows:
 - 1. Center rings/sleeves and all interior/wetted surfaces: Fusion bonded epoxy meeting requirements of AWWA C213 and NSF 61
 - 2. End rings/followers and other exterior surfaces: Fusion bonded polyester, 5 mil thickness

PART 3 EXECUTION

3.01 INSTALLATION OF FLEXIBLE PIPE COUPLINGS

- A. Clean oil, scale, rust, and dirt from pipe ends. Clean gaskets in flexible pipe couplings before installing.
- B. Install expansion joints per manufacturer's written recommendations.
- C. Install expansion joints so that 50-percent of total travel is available for expansion and 50-percent is available for contraction.
- D. Lubricate bolt threads with graphite and oil prior to installation.

3.02 FIELD COATING

- A. Wrap the couplings with 8-mil polyethylene wrap per AWWA C105. Wrap beyond coupling by 12 inches on both sides.
- B. Apply cosmoline grease corrosion guard, per Section 15056, to all hardware.
- C. Coat all non-buried pipe couplings per requirements of Section 09900. Apply prime coat at factory.

3.03 HYDROSTATIC TESTING

- A. Hydrostatically test flexible pipe couplings, expansion joints, and expansion compensators in place with the pipe being tested. Test in accordance within Section 15042.

END OF SECTION

SECTION 15170

WALL AND SLAB PENETRATIONS

PART 1 GENERAL

1.01 SECTION INCLUDES

- A. Wall Pipe Modular Seals
- B. Wall Pipes and Sleeves

1.02 REFERENCED STANDARDS

- A. American Iron and Steel Institute (AISI)
- B. American Water Works Association (AWWA):
 - 1. AWWA C115: Flanged Ductile-Iron Pipe with Ductile-Iron or Gray-Iron Threaded Flanges
 - 2. AWWA C210: Liquid-Epoxy Coating Systems for the Interior and Exterior of Steel Water Pipelines
 - 3. AWWA C116: Protective Fusion-Bonded Epoxy Coatings for the Interior and Exterior Surfaces of Ductile-Iron and Gray-Iron Fittings

1.03 SUBMITTALS

- A. Submit the following for each type of product specified:
 - 1. Product data including dimensions, materials, and pressure ratings
 - 2. Shop Drawings
 - 3. Certifications

PART 2 PRODUCTS

2.01 WALL PIPE MODULAR SEALS

- A. Description
 - 1. Inter-locking synthetic rubber links shaped to continuously fill the annular space between the pipe and the wall opening
 - 2. Sized and selected per the manufacturer's recommendations
- B. Performance Criteria
 - 1. Seal pressure rating: 20 psig

C. Materials

1. Links: Nitrile rubber
2. Hardware: AISI Type 316 Stainless Steel
3. Pressure Plates: Reinforced nylon polymer

2.02 WALL PIPES AND SLEEVES

A. Description

1. General:
 - a. Pipes or sleeves cast into concrete wall
 - b. Provide integral wall collar, continuously welded to pipe or sleeve, to control water seepage along the outside of the pipe or sleeve through the concrete wall.
 - c. Wall collar size per AWWA C115
 - d. Center wall collar in wall to avoid wall reinforcement.
2. Wall pipes:
 - a. Connected to adjacent pipe per plans
 - b. Size per plan; match connecting piping.
3. Wall sleeves:
 - a. Allow a carrier pipe to pass through wall sleeve.
 - b. Sleeve diameter per wall pipe modular seal manufacturer
 - c. Schedule 40 thickness (minimum)

B. Materials:

1. Wall Pipes: Match connecting piping, except provide ductile iron wall pipe for plastic connecting pipes.
2. Wall Sleeves: AISI Type 316L Stainless Steel

C. Finishes:

1. Wall Pipes (interior and exterior): Conform to AWWA C210 or AWWA C116.
2. Wall Sleeves: None

PART 3 EXECUTION

3.01 WALL PIPE MODULAR SEALS

- A. Install according to the manufacturer's written instructions and recommendations.
- B. Install on all pipes passing through wall sleeves in concrete walls.

3.02 WALL PIPES AND SLEEVES

- A. Provide wall pipes for all pipes passing through concrete walls or slabs, unless otherwise noted.
- B. Position wall pipes and sleeves in place with temporary, external supports. Prevent contact with reinforcement or other embedments.
- C. Inspect coatings prior to concrete placement. Repair any damage to the coating system in accordance with the manufacturer's written recommendations.
- D. Cast wall pipes and sleeves directly into concrete wall or slab. Wall blockouts are not allowed.

END OF SECTION

SECTION 15300

AUTOMATIC CONTROL VALVES

PART 1 GENERAL

1.01 SECTION INCLUDES

- A. Globe valves
- B. Check valves
- C. Solenoid control valves
- D. Pressure reducing valve
- E. Pressure relief valves
- F. Surge anticipated valves
- G. Pump control valves
- H. Altitude valves

1.02 RELATED REQUIREMENTS

- A. Section 09900, Painting and Coating
- B. Section 15042, Hydrostatic Testing of Pressure Pipelines
- C. Section 15056, Ductile-Iron Pipe and Fittings
- D. Section 15057, Copper, Brass, and Bronze Pipe Fittings and Appurtenances

1.03 REFERENCED STANDARDS

- A. ASTM International
 - 1. ASTM B62: Standard Specification for Composition Bronze or Ounce Metal Castings
- B. American Water Works Association
 - 1. AWWA C210: Liquid-Epoxy Coating Systems for the Interior and Exterior of Steel Water Pipelines
 - 2. AWWA C213: Fusion-Bonded Epoxy Coating for the Interior and Exterior of Steel Water Pipelines
 - 3. AWWA C550: Standard Test Method for Measuring Trueness and Squareness of Rigid Block and Board Thermal Insulation
- C. NSF International (NSF)

1. NSF 61: Drinking Water System Components – Health Effects

1.04 SUBMITTALS

- A. Product data sheets
- B. Materials
- C. Pressure rating
- D. Shop drawings
- E. Hydraulic characteristic curves and data

PART 2 PRODUCTS

2.01 GENERAL

- A. All valves shall be complete, with all necessary operating appurtenances included in the work under this section.
- B. Valves shall have the name of the manufacturer and the size of the valve cast or molded onto the valve body or bonnet or shown on a permanently attached plate.
- C. Valve body and trim casting shall be of domestic origin.
- D. Bolts and nuts for flanged valves shall be Type 316 stainless steel in accordance with Section 15056.

2.02 GLOBE VALVE

- A. All control valve applications shall be based on a hydraulically operated, diaphragm-actuated, globe pattern valve. It shall contain a resilient, synthetic rubber disc, having a rectangular cross-section, contained on three and one-half sides by a disc retainer and forming a tight seal against a single removable seat insert. The diaphragm assembly contacting a valve stem shall be fully guided at both ends by a bearing in the valve cover and an integral bearing in the valve seat. This diaphragm assembly shall be the only moving part and shall form a sealed chamber in the upper portion of the valve, separating operating pressure from line pressure. The diaphragm shall consist of nylon fabric bonded with synthetic rubber and shall not be used as a seating surface. Packing glands and/or stuffing boxes are not permitted and there shall not be pistons operating the valve.
- B. Valve shall be of indicated size and shall be of manufacturer's standard ductile iron with stainless steel trim (seat, disc guide, cover bearing, stem nut, and stem). Valve shall have a pressure rating of 150 or 300 psi, depending on the service application, with the appropriate class ductile iron flanges.

- C. The design shall preclude cavitation erosion, fouling of working surfaces, and other effects adverse to reliability. Seats and other trim shall be secured by means precluding their loosening by hydraulically induced vibrations; and the fit of stems in guides and guide lengths shall preclude any binding, scraping, or deviation from true alignment affecting the free movement of working parts.
- D. All repairs shall be possible without removing the valve from the pipeline.

2.03 CHECK VALVE

- A. The check valve shall consist of a globe valve with the appropriate pilot system.
- B. The pilot shall contain auxiliary controls which permit the adjustment of the opening and closing speeds, and shall be set for fast opening and slow closing.
- C. Pilot valves shall be all bronze conforming to ASTM B62 with stainless steel trim. Hydraulic control and sensing lines shall be copper, conforming to Section 15057.

2.04 SOLENOID CONTROL VALVE

- A. The solenoid control valve shall consist of a globe valve with the appropriate pilot system.
- B. The pilot control shall be a solenoid valve controlling a diaphragm-operated three-way auxiliary valve. The control system shall include opening and closing speed controls, a wye strainer, and limit switch Model X105LCW.
- C. Pilot valves shall be all bronze conforming to ASTM B62 with stainless steel trim. Hydraulic control and sensing lines shall be copper, conforming to Section 15057, herein.

2.05 PRESSURE REDUCING VALVE

- A. The pressure reducing valve shall consist of a globe valve with the appropriate pilot system.
- B. The pilot control shall be a direct-acting, adjustable, spring-loaded, diaphragm valve, designed to permit flow when controlled pressure is less than the spring setting. The control system shall include a fixed orifice.
- C. The pilot valve system shall have a direct-acting, adjustable, spring-loaded pilot, diaphragm actuated valve, designed to permit flow in the pilot valve system whenever the controlling pressure exceeds the spring setting. The pilot valve system shall also contain a strainer needle valve assembly that shall control the opening of the main valve.
- D. Pilot valves shall be all bronze conforming to ASTM B62 with stainless steel trim. Hydraulic control and sensing lines shall be copper, conforming to Section 15057.

2.06 PRESSURE RELIEF VALVE

- A. The pressure relief valve shall consist of a globe valve with the appropriate pilot system.

- B. The pilot valve system shall have a direct acting, adjustable, spring-loaded pilot, diaphragm actuated valve, designed to permit flow in the pilot valve system whenever the controlling pressure exceeds the spring setting. The pilot valve system shall also contain a strainer needle valve assembly that shall control the closing of the main valve.
- C. Pilot valves shall be all bronze conforming to ASTM B62 with stainless steel trim. Hydraulic control and sensing lines shall be copper, conforming to Section 15057.

2.07 SURGE ANTICIPATOR VALVE

- A. The surge anticipator valve shall consist of a globe valve with the appropriate pilot system.
- B. The pilot control shall be a direct-acting, adjustable, spring-loaded, diaphragm valve. The pilot valve system shall contain a strainer needle valve assembly that shall control the closing of the main valve. The pilot valve system shall also contain a check valve that is installed on one of the main valve cover connections. This check valve shall be so installed that if low pressure occurs at the inlet of the valve, it will open and relieve the cover pressure to the inlet side of the valve.
- C. Pilot valves shall be all bronze conforming to ASTM B62 with stainless steel trim. Hydraulic control and sensing lines shall be copper, conforming to Section 15057.

2.08 PUMP CONTROL VALVE - BOOSTER TYPE

- A. This valve shall be a hydraulically operated, single seated, diaphragm actuated, composition disc, dual-port globe style valve with solenoid valve control. The valve shall have a built-in check feature; designed to operate with pump controls to start and stop the pump against a closed valve.
- B. Valves shall have emergency shutdown power check features for surge protection as described below: upon power failure, solenoids de-energize and a check valve in the diaphragm unit shall release to effect closure under spring action when flow stops before flow reversal can occur.
- C. Pilot valves shall be all bronze conforming to ASTM B62 with stainless steel trim. Hydraulic control and sensing lines shall be copper, conforming to Section 15057.
- D. A manual control override shall be provided on the valve assembly. The design shall preclude cavitation erosion, fouling of working surfaces, and other effects adverse to reliability. Seats and other trim shall be secured by means precluding their loosening by hydraulically induced vibrations; and the fit of stems in guides and guide lengths shall preclude any binding, scraping, or deviation from true alignment affecting the free movement of working parts.
- E. The valve shall be provided with a SPDT limit switch actuated by the control rod. The switch shall indicate:
 - 1. When the valve is fully closed
 - 2. When the valve is not fully closed

2.09 ALTITUDE VALVE

- A. The altitude valve shall consist of globe valve with the appropriate control system.

- B. The control system shall consist of auxiliary valves working in conjunction with the pilot valve to control the main valve. The pilot valve is to be controlled by the difference between the reservoir pressure and an adjustable spring pressure with a spring range of 5-40 feet of water. The entire valve and control assembly shall be designed so that no surface water can be drawn into the pilot system or the main valve at any time.

2.10 BOLTS AND NUTS FOR FLANGED VALVES

- A. Bolts and nuts for flanged valves shall be Type 316 stainless steel in accordance with Section 15056.

2.11 GASKETS

- A. Gaskets for flanged end valves shall be as described in Section 15056.

2.12 FACTORY FINISHES

- A. Coat all ferrous surfaces.
 - 1. Interior surfaces:
 - a. Fusion bonded epoxy meeting requirements of AWWA C213
 - b. Liquid-epoxy meeting requirements of AWWA C210 allowed for touch up and when valve design uses bonded rubber seats
 - c. Conform to requirements of NSF 61 for interior coatings.
 - 2. Exterior surfaces: factory primer

PART 3 EXECUTION

3.01 FIELD COATING

- A. Valve Exterior Surface, Above Grade or in Vault: Apply coatings per Section 09900. Coat all valve metal surfaces, except bronze and stainless steel surfaces.

3.02 VALVE LEAKAGE TESTING

- A. Test valves for leakage at the same time that the connecting pipelines are tested. See Section 15042 for pressure testing requirements.
- B. Valves shall have a pressure rating higher than or equal to the test pressure.
- C. All valves 16-inch and larger shall be hydrostatically shop tested to the valves working pressure in the presence of the District inspector. Each side of the valve shall be tested independently. Exterior epoxy shall be touched up as required. After testing, valves shall be palletized, shrink wrapped, and delivered to the job site.

3.03 MANUFACTURER'S SERVICES

- A. A manufacturer's representative for the equipment specified herein shall be present at the job site and/or classroom designated by the District for the minimum personnel days listed for the services hereunder, travel time excluded:
1. One (1) personnel day for equipment start up, and
 2. One (1) personnel-day for post start-up training
 3. Start up services and training of District's personnel shall be at such times as requested by the District.

END OF SECTION

SECTION 16010

ELECTRICAL GENERAL PROVISIONS

PART 1 - GENERAL

A The Requirement

1. General:
 - a. The Contractor shall provide all tools, materials, equipment, and labor necessary for the furnishing, construction, installation, testing, and operation of all electrical Work necessary to provide a complete and operable system, all in accordance with the requirements of the Contract Documents.
 - b. The provisions of this Specification section shall apply to all electrical items specified in the various sections of Division 16 and all other Specification divisions specifying electrical items, except where otherwise indicated in the Contract Documents.
 - c. Persons performing work as electricians under a C-10 licensed contractor shall be certified pursuant to certification standards established by the Division of Labor Standards Enforcement. "Electricians" is defined as all persons who engage in the connection of electrical devices for electrical contractors licensed pursuant to Section 7058 of the Business and Profession Code, specifically, contractors classified as electrical contractors in the Contractor's State License Board Rules and Regulations [Labor Code § 108 (c)].
 - d. The Contractor shall demolish electrical connections to mechanical equipment, electrical equipment and instrumentation as described in the Contract Documents. The Contractor shall disconnect, preserve and prepare for reconnection equipment that is to be replaced. Where equipment is replaced, the Contractor shall update the electrical installation to reflect current codes.
2. The Contractor shall be responsible for:
 - a. Complete systems in accordance with the intent of these Contract Documents.
 - b. The Contractor shall coordinate the details of facility equipment and construction for all Specification divisions which affect the Work covered under Division 16, Electrical.
 - c. The Contractor shall furnish and install all incidental items not actually shown or specified, but which are required to provide complete functional systems.
 - d. The Contractor shall notify the DISTRICT in writing 48 hours in advance of energizing any new electrical equipment or de-energizing of any existing equipment. If the energization or de-energization is rescheduled, a new notification shall be made. The Contractor shall not proceed with energization or de-energization without approval by the DISTRICT.
 - e. The Contractor shall be responsible for coordination with the utility company through all phases of the Work.
 - f. Temporary Power: The Contractor shall furnish, install, and maintain all temporary power and lighting systems needed for construction. This temporary power system shall include weatherproof panel(s) for the Contractor's main circuit breakers, power distribution system, and ground fault interrupting equipment. All connections shall be watertight with wiring

done with Type SO portable cable as a minimum. The Contractor shall remove all temporary power, equipment and devices after construction is completed.

3. Existing Conditions:
 - a. Carry out any Work involving the shutdown of existing services to any piece of equipment now functioning and the tie-in of equipment to the existing system at such time as to provide the least amount of inconvenience to the DISTRICT. Do such Work when directed by the DISTRICT.
 - b. Construction Coordination and Electrical Downtime: See the Section 01115 and the Special Provisions of these Specifications regarding scheduling of electric power interruptions.
 - c. Prior to starting any underground Work, the Contractor shall obtain all the information of the underground utilities and obstructions from the DISTRICT and take proper precautions to locate the utilities by potholing or other means acceptable to the DISTRICT.
4. Intent of Drawings: The Drawings show only general locations of equipment, devices, and raceway, unless specifically dimensioned. The Contractor shall be responsible for the proper routing of raceway, subject to acceptance by the DISTRICT.
5. Work Provided Outside this Contact:
 - a. Incoming underground power cables, materials, installation, termination, and connection; under this Contract, provide trench, and backfill, and duct system.
 - b. Pump station bypass pumping will be provided by the DISTRICT. The Contractor shall coordinate with and accommodate the DISTRICT's bypassing operation as needed.

B. Related Work Specified Elsewhere

1. The requirements of the following sections and divisions apply to the Work of this section. Other sections and divisions of these Specifications, not referenced below, shall also apply to the extent required for proper performance of this Work.
 - a. Section 01115, Construction Sequencing and Work Restrictions
 - b. Section 01782, Operation and Maintenance Manuals
 - c. Section 01810, Commissioning Requirements
 - d. Section 09900, Protective Coating
 - e. Division 16, Electrical, other applicable sections

C. Reference Specifications, Codes and Standards

1. All Work specified herein shall conform to or exceed the applicable requirements of the referenced portions of the following publications to the extent that the provisions thereof are not in conflict with other provisions of these Specifications.
2. Comply with the applicable editions of the following codes, regulations, and standards.
 - a. Code and Regulations:

29 CFR 1910	Code of Federal Regulations, Title 29, Part 1910, U.S. Occupational Safety and Health Standards (OSHA)
-------------	--

CCR	California Code of Regulations, Title 8, Div. 1, Chap. 4, Subchapter 5, Electrical Safety Orders
CCR	California Code of Regulations, Title 8, Industrial Relations (Cal/OSHA), other applicable provisions
CCR	California Code of Regulations, Title 24, Building Standards Code
ADAAG	Americans with Disabilities Act (ADA), Accessibility Guidelines for Buildings and Facilities.
NFPA 70	National Electrical Code (NEC)

b. Industry Standards:

NECA	National Electrical Installation Standards (NEIS)
------	---

c. Other Standards: All electrical equipment and materials shall be designed, manufactured, and installed in accordance with the latest published edition of the applicable standards of the following standard-making organizations. Specific standards are identified in the various sections for specific types of equipment and materials:

ANSI	American National Standards Institute
ASTM	ASTM International (formerly, American Society for Testing and Materials)
CSA	Canadian Standards Association
FM	FM Approvals (formerly, Factory Mutual Research Corporation)
ICEA	Insulated Cable Engineers Association
IEEE	Institute of Electrical and Electronics Engineers
NECA	National Electrical Contractors Association
NEMA	National Electrical Manufacturers Association
NETA	InterNational Electrical Testing Association
UL	Underwriters Laboratories

3. All Work specified herein shall conform to or exceed the applicable requirements of the NFPA 70 - National Electric Code (NEC) and California Electrical Code. Where provisions of the NFPA 70 and the California Electrical Code are in conflict, the more stringent provisions, as interpreted by the applicable authority having jurisdiction, shall govern. Where a local code or ordinance is in conflict with the NFPA 70 and California Electrical Code, the provisions of said local code ordinance shall take precedence.

4. Comply with the applicable reference Specifications as directed in the General Provisions and the Special Provisions.

D. Contractor Submittals

1. Submittals shall be in accordance with the General Provisions, the Special Provisions, and Section 01330 as specified herein. Submittals shall include the following:
 - a. Shop drawings: Shop drawings shall provide sufficient information to evaluate the suitability of the proposed material and equipment for the intended use and for compliance with the Contract Documents. The Contractor shall also clearly state deviations from the Contract Documents on the first page of the submittal. The Contractor shall review the shop drawings for compliance with the Contract Documents before submitting them to the DISTRICT for review. Shop drawings shall include the following:
 - (1) Equipment front, side, and rear elevations, footprints, top views, and internal component layout with dimensions
 - (2) Location and size of conduit entrances and access plates
 - (3) Component data
 - (4) Material lists show manufacturer and brand name of each item or class of material
 - (5) Elementary diagrams, block diagram, connection and interconnection diagrams
 - (6) Elementary diagrams shall include individual elementary (schematic) diagram (drawing) for all equipment. Adaptor tables shall not be used except as accepted by the DISTRICT. Elementary diagrams shall show tag numbers, fuse sizes, control power transformer voltage and VA ratings, wire numbers, terminal block numbers, terminal numbers, PLC input/outputs with tag numbers and descriptions, and all related internal and external control devices. The wire number shall be the rung number next to the wire. Use suffixes, as needed, for rung with more than one wire.
 - (7) Wiring (connection and interconnection) diagrams shall show all connections, devices, terminal numbers, cable number, and item designations. These diagrams should show the various components in their relative physical location. Diagrams shall be prepared in AutoCAD format. All the text information on the diagrams shall be added as AutoCAD attributes to facilitate export of the information to Microsoft Excel format files.
 - (8) One line diagrams and three-line diagrams, as applicable
 - (9) Method of anchoring and weight
 - (10) Finish color and painting method
 - (11) Nameplate locations, color, legend, size, and mounting methods
 - (12) Temperature limitations and special cooling requirements, as applicable
 - (13) Rating of equipment per Contract Documents
 - (14) NEMA rating and material of enclosures
 - (15) UL, FM, or agency listings acceptable to the DISTRICT.
 - b. Contractor-prepared Drawings: Drawings prepared by the Contractor for construction shall include the following:

- (1) Drawing sheet sizes shall be 11 inches by 17 inches or 22 inches by 34 inches. Maximum drawing sheet size shall be 22 inches by 34 inches. All drawings shall be legible when printed as half-size drawings. Drawings shall be prepared using AutoCAD software. Software version shall be the latest or as accepted by the DISTRICT.
- c. Catalog Data: Catalog cuts, bulletins, and brochures shall be submitted for mass-produced, non-custom manufactured material. These documents shall show Project name, Project number, applicable Specification section and paragraph. Applicable model number and options shall be annotated.
- d. Installation, Operation, and Maintenance Manuals: The Contractor shall furnish these manuals as specified under Operation and Maintenance Manuals of the General Provisions, Special Provisions, Section 01330, Section 01782 and as specified herein.
- e. Recommended Spare Parts List: A recommended spare parts list shall be submitted for each piece of equipment. The DISTRICT will order the appropriate spare parts for use. The Contractor shall also furnish the name, address, and telephone number of the nearest distributor for each piece of equipment.
- f. Equipment seismic restraint design and calculations: The design and calculations shall be stamped and signed by a Professional Civil Engineer or Structural Engineer registered in the State of California.
- g. A Material Safety Data Sheet (MSDS) shall be provided for each type of paint solvent, cleaner, oil, etc. supplied.
- h. Standard test reports for mass-produced equipment shall be submitted along with the shop drawing for such equipment. Factory and field test reports on testing specifically required for individual pieces of equipment shall be submitted to the DISTRICT for review prior to Final Acceptance of the Project.
- i. Methods for temporary storage and protection of electrical equipment and material.

E. Quality Assurance

- 1. General:
 - a. Comply with the requirements specified herein and the applicable reference Specifications of the General Provisions and the Special Provisions.
 - b. Tests: The Contractor shall make all tests as specified. All such tests shall be performed in the presence of the DISTRICT. The Contractor shall furnish all necessary testing equipment and pay all costs of tests, including rework and retest resulting from faulty installation and/or noncompliance with Specifications. Operational testing shall be performed on all equipment furnished to confirm they function as intended.
 - c. Any material and equipment that fails the field tests shall be replaced, repaired, and retest until the specified requirements are met.
- 2. Contractor Qualifications:
 - a. Comply with the requirements for the certifications, licenses, training, skills, experience, and other qualifications specified in Part 3, Article entitled “General” of this Specification.

- b. Comply with the requirements for the certifications, licenses, training, skills, experience, and other qualifications specified in Part 3, Article entitled “Checkout and Startup” of this Specification.

F. Site Conditions

1. General:

- a. The Contractor personnel and material storage area shall be arranged at Contractor’s expense as specified in Section 12 of the Special Provisions of this Specification.
- b. On-site parking is extremely limited. Parking is not allowed along the street. The Contractor shall make suitable arrangements at Contractor’s expense to park their vehicles off site as specified in the Special Provisions of this Specification.
- c. Use of vehicles and equipment required to deliver, offload and load-out project equipment and components may require traffic control and an encroachment permit from the city or the agency having jurisdiction.
- d. Seismic Requirements: The installation of the equipment and appurtenances furnished under this Contract shall meet the requirements of California Seismic Zone 4 and as specified in Section 01640.

G. Warranty

- 1. Provide an unlimited one year materials and labor warranty for all electrical and instrumentation described in the Contract Documents.
- 2. The warranty period shall commence upon the DISTRICT’s acceptance of the Contractor’s notice of final completion.

PART 2 - PRODUCTS

A. General

- 1. All equipment furnished by the Contractor shall be listed by and bear the label of UL, FM, or an OSHA-recognized testing laboratory.
- 2. All electrical equipment and materials shall be capable of operating successfully at full-rated load, without failure, at an ambient temperature of 55 degrees C (130 degrees F).

B. Hazardous Areas

- 1. Provide materials and equipment acceptable to the regulatory Authority Having Jurisdiction (AHJ) for the Class, Division, and Group of hazardous area indicated.
- 2. Area classification drawings are provided as a guide to the Contractor in determining the NEC-required materials and methods to meet classification. However, the area classification drawings can neither detail nor anticipate actual field conditions. The Contractor is responsible for providing an electrical installation that meets classification as determined by the AHJ. The DISTRICT shall identify the project AHJ(s)

C. Area Designations

MOULTON NIGUEL WATER DISTRICT

- 1. General: Areas are classified as General Purpose Dry, Wet and Corrosive, and Wet, Corrosive, and Hazardous. Install electrical enclosures and conduit systems accordingly.

Area	Area Designation
Electrical room	General Purpose Dry
Outdoor locations	Wet and Corrosive
All other locations	Wet and Corrosive
Hazardous areas	Wet, Corrosive, and Hazardous

- a. General Purpose Dry Locations: The enclosures shall be NEMA 12 in electrical rooms, distribution centers, power buildings and air-conditioned rooms.
- b. Wet and Corrosive Locations: Entrances shall be threaded and fittings shall have gasketed covers. Provisions shall be made to drain the fittings and conduit system. Threaded fastening hardware shall be Type 316 stainless steel. Mounting brackets shall be hot dipped galvanized steel. Attachment and welded assemblies shall be hot dipped galvanized after fabrication. Instrument, control cabinets, and other enclosures shall be Type 316 stainless steel, NEMA 4X unless hazardous location requirements apply. Enclosures shall be mounted 1/4 inch from walls to provide air space, unless shown otherwise. Conduit systems shall be PVC-coated galvanized rigid steel conduits, fittings, and conduit boxes.
- c. Wet, Corrosive, and Hazardous Locations: Electrical installations shall be suitable for wet and corrosive as described above and Class 1, Division 1 or 2, Group C locations as required under Cal/OSHA Safety Orders (Title 8, CCR) and NFPA 70 & 820. Enclosures shall be NEMA Type 4X minimum and 7 where area classification dictates. Requirements for fastening hardware, mounting channels, brackets, and conduit systems shall be same as wet and corrosive locations.

D. Standard Products

- 1. Provide all new materials and equipment, free from any defects, in unblemished condition, and suitable for the space provided.
- 2. Where two or more units of the same class of material and/or equipment are required, provide products of a single manufacturer. Component parts of materials and/or equipment of the same manufacturer shall be preferred.
- 3. Provide materials and equipment of standard design and production. Provide the manufacturers' latest standard products that conform to these Specifications.
- 4. All materials and equipment shall be unused, of current manufacture, and of highest grade. All equipment and materials shall be of a proven type, and shall have a minimum of one year in service experience in similar service to that utilized in the Contract. No prototype equipment shall be installed. In addition, no equipment that is being phased out of manufacture by the supplier shall be installed.
- 5. Where equipment is to be replaced or matched and the original manufacturer no longer makes the original equipment, substitute manufacturer's recommended equipment.

6. Where equipment is to be replaced or matched and the original manufacturer is no longer in business, document and research suitable replacement equipment and submit to the DISTRICT.
 7. The fabricator of major equipment assemblies, such as distribution panelboards, switchgear, MCCs, etc. shall also be the manufacturer of the major devices and components contained therein.
- E. Equipment Finish
1. Provide materials and equipment with manufacturers' standard finish system. Provide manufacturers' standard finish color, except where specific color is indicated. If manufacturer has no standard color, finish equipment with ANSI No. 61, light gray color, or equal.
- F. Outdoor Equipment
1. Provide equipment and devices to be installed outdoors or in unheated enclosures capable of continuous operation within an ambient temperature range of 30 degrees F to 130 degrees F. Enclosures shall be NEMA 3R or as noted on the Contract Drawings.
- G. Special Tools
1. The Contractor shall provide all special tools required for operation and maintenance of the equipment. The tools shall be considered as part of the product and become the property of the DISTRICT.

PART 3 – EXECUTION

- A. General
1. Install materials and equipment in a workmanlike manner utilizing craftsmen skilled in the particular trade. Installations shall have a neat and finished appearance. Carry out Work in accordance with NECA National Electrical Installation Standards unless specified otherwise.
 2. Coordinate electrical Work with the DISTRICT and Work of all other trades to avoid conflicts, errors, delays, and unnecessary interference with operation of the plant during construction.
 3. The Contract Documents are not intended to show every offset and fitting, or every structural and mechanical obstruction that will be encountered during the installation of the Work. The alignment of equipment and raceways may be varied due to architectural changes, or to avoid work of other trades. Electrical system installations shall be integrated with all existing facilities and the work of other disciplines in this Contract. Accommodation of existing conditions and conditions developed by the Contractor shall be at no extra cost to the DISTRICT.
 4. Raceway sizes, numbers of cables, and conductors, as shown on the Contract Documents, may vary in accordance with actual field conditions and equipment installed. The Contractor shall obtain the DISTRICT's acceptance for any deviations.
 5. Field Control of Location and Arrangement: The Drawings diagrammatically indicate the desired location and arrangement of outlets, conduit runs, equipment, and other items.

Exact locations shall be determined by the Contractor in the field based on the physical size and arrangement of equipment, finished elevations, required clearances, and other obstructions. Locations shown on the Contract Documents, however, shall be adhered to as closely as possible.

6. Where the Contract Documents do not indicate exact locations of conduit routing and equipment placement, the Contractor shall submit proposed locations to the DISTRICT for review. Where equipment is installed without instruction and the DISTRICT directs that it be relocated, it shall be moved as directed without additional cost to DISTRICT.
7. All materials and equipment shall be installed in accordance with the recommendations of the manufacturer or as agreed by the DISTRICT. The installation shall be coordinated in the field with other trades so that interferences are avoided.
8. All Work, including installation, connection, calibration, testing, and adjustment shall be accomplished by qualified and experienced personnel working under continuous, competent supervision. The completed installation shall display competent work, reflecting adherence to prevailing industrial standards and methods.
9. All electrical installations with connections greater than 100 VA shall be performed by a C-10 Electrical Contractor licensed in the State of California or by an electrician participating in the certified electrician program of the State of California.
10. All faulty electrical equipment shall be repaired or replaced by factory-trained representatives in a manner acceptable to the DISTRICT. Factory technical representatives shall be provided during start-up of all systems.

B. Material and Equipment Protection

1. All materials and equipment shall be covered or protected in such a manner that no finished surfaces are damaged, marred, or splattered with foreign material. All moving parts shall be kept clean and dry. The Contractor shall replace or have rehabilitated by the manufacturer, all damaged materials and equipment at no expense to the DISTRICT.
2. All electrical equipment and skid mounted equipment shall be shipped in sealed dust- and moisture-proof plastic sheet enclosures.
3. Follow manufacturers' recommendations for handling, storage, and protection of material and equipment. Protect everything from the effects of weather, condensation, and corrosion. Before installation, store indoor equipment and equipment with electrical insulations such as motors in clean and dry indoor locations. Provide temporary power and heating acceptable to the DISTRICT, to prevent equipment condensation.
4. Protect equipment and material in a manner acceptable to the DISTRICT.
5. Cap conduit runs during construction with manufactured seals. Keep openings in boxes and equipment closed during construction.

C. Material and Equipment Installation

1. Follow manufacturers' installation instructions explicitly. Wherever any conflict arises between the manufacturers' instructions, codes and regulations, and the Contract Documents, resolve the conflict and obtain acceptance by the DISTRICT. Keep copy of manufacturers' installation instructions on the jobsite available for reference at all times.

2. Provide appropriate conduit and conductor entry fittings with enclosures to maintain the specified enclosure environmental capability after proper installation.
3. Equipment Installation
 - a. Equipment shall be anchored to accommodate all operating forces and seismic forces. Equipment shall be secured in accordance with the manufacturer's recommendations and Contractor's seismic restraint design and calculations.
 - b. Electrical equipment shall be secured with 1/2-inch Type 316 stainless steel concrete anchors or welded to channels as recommended by the manufacturer and seismic calculations. Equipment shall be installed level and aligned in place. Voids shall be filled with grout. Openings through slabs under equipment, wall, and ceiling shall be sealed around conduit with grout, synthetic rubber sealing compound, or other means acceptable to the DISTRICT. Conduit passing through these penetrations shall have both end openings sealed with conduit sealant acceptable to the DISTRICT.
 - c. Holes made in existing and new structures to accommodate electrical installations shall be neatly formed without rough edges. Repairs to damage caused during installation shall be made in a manner acceptable to the DISTRICT.
4. Torque on Conductor Terminations: After installation and before energizing electrical equipment, each bolted bus and cable connection both factory and field installed shall be torqued to the manufacturer's recommended values.

D. Removal and Relocation of Materials and Equipment

1. Where existing materials and equipment are removed or relocated, remove all materials no longer used such as studs, straps, conduits, and wires (entire length). Remove or cut off concealed and embedded conduit, boxes, and other materials and equipment to a point at least 3/4 inch below the final finished surface and capped.
2. Repair affected surfaces to conform to the type, quality, and finish of the surrounding surface in a neat and workmanlike manner.

E. Cutting and Patching

1. Lay out Work carefully in advance. Do not cut, core-drill, and/or notch any structural member and building surface without specific acceptance by the DISTRICT. Carefully carry out any cutting, channeling, chasing, and drilling of floors, walls, partitions, ceilings, paving, and other surfaces required for the installation, support, and anchorage of conduit, raceways, and other electrical materials and equipment. Following such Work, restore surfaces neatly to original condition.
 - a. Prior to core-drilling and/or saw-cutting of existing concrete structures, verify with the DISTRICT whether X-ray testing is required for the related concrete area to identify embedded objects. Perform X-ray testing if directed so by the DISTRICT.

F. Load Balance

1. The Drawings show circuiting to electrical loads. Balance electrical load, if needed, among phases as nearly as possible on switchboards and panelboards. Submit the proposed changes to the DISTRICT in writing before proceeding.

G. Phasing Sequence

1. Coordinate service entrance and motor phasing checks with the DISTRICT. Submit a written report to the DISTRICT for each service entrance verifying that phasing has been checked for correct rotation.

H. Cleaning and Touchup Painting

1. Keep the premises free from accumulation of waste material and/or rubbish. Remove demolished equipment from the site within 3 days. Upon completion of Work, remove all materials, scraps, and debris from premises and from interior and exterior of all devices and equipment. Touch up scratches, scrapes, and chips in interior and exterior surfaces of devices and equipment with finishes matching as nearly as possible the type, color, consistency, and type of surface of the original finish. If extensive damage is done to equipment paint surfaces, refinish the entire equipment in a manner that provides a finish equal to the factory finish and acceptable to the DISTRICT.
2. All parts of the materials and equipment shall be thoroughly cleaned before energization and leave the equipment in a safe condition for the DISTRICT's operators and maintenance personnel.

I. Hazardous Areas

1. Install all materials and equipment in hazardous areas in a manner acceptable to the regulatory authority having jurisdiction for the Class, Division, and Group of hazardous area indicated.

J. Inspection

1. Allow materials, equipment, and workmanship to be inspected at any time by the DISTRICT. Correct Work, materials, and equipment not in accordance with the Contract Documents, and/or found to be deficient or defective in a manner acceptable to the DISTRICT.

K. Service Continuity

1. Maintain continuity of electric service to all functioning portions of the process and buildings during hours they are normally in use. Outages, if needed, shall be requested from the DISTRICT in writing. The requests shall include the reasons for outage, date, time, duration and equipment/system affected. A pre-outage meeting shall be held between the Contractor and the DISTRICT to review the impact on plant operation, safety, and other issues. Make no outages without written approval by the DISTRICT. All costs for temporary wiring and overtime work required for the outage shall be at no cost to the DISTRICT. Remove all temporary wiring at the completion of the Work.

L. Checkout and Startup

1. During checkout and startup of the various plant systems, provide a crew of skilled craftsmen to be at site for checkout and troubleshooting activities as required by the DISTRICT. Since coordination with other crafts and contractors will often be required, the craftsmen assigned to checkout shall be at site outside normal working hours, when necessary.

M. Tests

1. General: Carry out tests as indicated in Section 16080 and under individual items of materials and equipment specified in other Specification sections.

N. Training

1. Contractor shall conduct on-site training of newly installed and modified electrical equipment.

END OF SECTION

SECTION 16050

BASIC MATERIALS AND METHODS

PART 1 - GENERAL

A The Requirement

1. The Contractor shall furnish all tools, equipment, materials, and supplies and shall perform all labor required to complete the Work as indicated in the Contract Documents.

B. Related Work Specified Elsewhere

1. The requirements of the following sections and divisions apply to the Work of this section. Other sections and divisions of the Specifications, not referenced below,
 - a. Section 09900, Protective Coating
 - b. Section 16010, Electrical General Provisions
 - c. Section 16075, Electrical Identification Nameplates and Warning Signs
 - d. Division 16, Electrical, other applicable sections

C. Reference Specifications, Codes and Standards

1. All Work specified herein shall conform to or exceed the applicable requirements of the referenced portions of the following publications to the extent that the provisions thereof are not in conflict with other provisions of these Specifications.
2. Comply with the applicable editions of the following codes, regulations, and standards.
 - a. Code and Regulations:

29 CFR 1910	Code of Federal Regulations, Title 29, Part 1910, U.S. Occupational Safety and Health Standards (OSHA)
CCR	California Code of Regulations, Title 8, Div. 1, Chap. 4, Subchapter 5, Electrical Safety Orders
CCR	California Code of Regulations, Title 24, Part 3, California Electrical Code
ADAAG	Americans with Disabilities Act (ADA), Accessibility Guidelines for Buildings and Facilities.
NFPA 70	National Electrical Code (NEC)
 - b. Industry Standards:

ANSI C80.1	Electrical Rigid Steel Conduit (ERSC)
ASTM E814	Standard Test Method for Fire Tests of Penetration Firestop Systems

MOULTON NIGUEL WATER DISTRICT

IEEE C62.41.1	Guide on the Surge Environment in Low-Voltage (1000 V and Less) AC Power Circuits
IEEE C62.41.2	Recommended Practice on Characterization of Surges in Low-Voltage (1000 V and Less) AC Power Circuits
IEEE C62.45	Recommended Practice on Surge Testing for Equipment Connected to Low-Voltage (1000 V and Less) AC Power Circuits
NEMA ICS 2	Controllers, Contactors and Overload Relays Rated 600 V
NEMA LA 1	Surge Arresters
NEMA KS 1	Enclosed and Miscellaneous Distribution Equipment Switches (600 Volts Maximum)
NEMA PB 1	Panelboards
NEMA VE 1	Metal Cable Tray Systems
NEMA WD 1	General Color Requirements for Wiring Devices
UL 467	Grounding and Bonding Equipment
UL 489	Molded-Case Circuit Breakers, Molded-Case Switches, and Circuit-Breaker Enclosures
UL 943	Ground-Fault Circuit-Interrupters
UL 1449	Surge Protective Devices
UL 1479	Standard for Fire Tests of Through-Penetration Firestops
W-C-596G	Federal Specifications, General Specification for Connector, Electrical, Power
W-S-896F	Federal Specifications, Switches, Toggle (Toggle and Lock), Flush Mounted (General Specification)
c.	Other Standards:
ANSI	American National Standards Institute
ICEA	Wire and Cable standards
IEEE	Institute of Electrical and Electronics Engineers
NEMA	National Electrical Manufacturers Association

D. Contractor Submittals

1. Submittals shall be made in accordance with Section 01330, the General Provisions, Special Provisions, and as specified herein. Also refer to Section 16010, Electrical General Provisions, for submittal requirements.

E. Quality Assurance

1. Comply with the requirements specified herein and the applicable reference Specifications of the General Provisions and Special Provisions.

PART 2 - PRODUCTS

A. Material Listing

1. All equipment and material shall be listed by Underwriters Laboratories, Incorporated and bear the UL label or an OSHA-recognized testing laboratory acceptable to the DISTRICT.

B. Hazardous Areas

1. Provide devices, materials, and equipment listed for installation in hazardous areas of the Class, Division, and Group indicated.

C. Outlet and Device Boxes

1. General: Provide boxes not less than 2 inches deep, unless shallower boxes are required by structural conditions and are specifically accepted by the DISTRICT. Do not use box extensions to provide wiring space required by the NEC and California Electrical Code. For hollow masonry construction, provide boxes of sufficient depth so that conduit knockouts and hubs are in the masonry void space.
2. Sheet Steel Boxes: Provide zinc-plated or cadmium-plated boxes of the one-piece drawn type. Install 4-inch minimum octagonal boxes for ceiling outlets, except where smaller boxes are required for the particular fixture being installed. Provide concrete type boxes in poured concrete slabs. Provide 4 inches by 4 inches minimum boxes with 3/4-inch knockouts for switches and receptacles. Provide plaster rings where required.
3. Cast Steel Boxes: Provide boxes of cast ferrous metal with gasketed, watertight, cast ferrous metal covers and stainless steel screws. Provide boxes with threaded conduit hubs and cast mounting lugs where lugs are required. Provide Type FS or FD boxes as manufactured by Crouse-Hinds, Appleton, or equal.
4. PVC-Coated Cast Steel Boxes: PVC-coated cast steel boxes shall meet the requirements of UL 514B and the NEC. Boxes shall be cast steel. The exterior PVC coating of the box shall have nominal thickness of 40 mils bonded to the box. The PVC coating shall be UV-resistant. The interior surfaces shall be lined with corrosion resistant coating to a nominal thickness of 2 mils. Box cover shall be PVC-coated steel and secured with Type 316 stainless steel screws.
5. Provide a box suitable for the conditions at each outlet in the wiring or raceway system and sized in accordance with the NEC and California Electrical Code.
6. Unless otherwise indicated on the Contract Documents, device boxes and junction boxes shall be heavy duty and compatible with the location and conduit system being used. Types to be provided shall be as follows:

Location	Box Type
Wet and corrosive area (outdoors)	PVC-coated cast steel
Encased in concrete or concealed	Cast steel
Wet, corrosive, and hazardous	PVC-coated cast steel (with factory sealed or explosion-proof devices)

7. Device Plates: Types to be provided:

Location	Plate Type
General purpose	Stainless steel
Wet and corrosive	Type 316 stainless steel with gasket or PVC-coated cast steel

D. Junction and Pull Boxes

1. Provide NEMA 4X PVC-coated or Type 316 stainless steel enclosures for wet and corrosive locations as well as where subscript WP is indicated on the Drawings.
2. Where outlet boxes are used as junction or pull boxes, provide materials as specified in Article entitled “Outlet and Device Boxes” of this Specification.
3. Where larger sheet steel boxes are required, provide boxes of code-gauge, galvanized steel for general purpose dry locations or NEMA 4X Type 316 stainless steel in wet and corrosive areas. All boxes shall be hinged and have full-access screw covers with Type 316 stainless steel machine screws and hardware.
4. Provide concrete boxes of reinforced, cast concrete, 10 inches by 17 inches minimum inside dimensions, Brooks Products, Inc., No. 3-1/2T, Quikset W.17 Associated, or equal. Mark cast iron cover, per the DISTRICT’s standards.
5. Provide special boxes where indicated on the Drawings.

E. Terminal Junction Boxes

1. Provide hinged-cover terminal junction boxes of the required type and size where indicated. Provide NEMA 1 gasketed or NEMA 12 enclosures for general purpose dry locations. Provide NEMA 4X Type 316 stainless steel enclosures for wet and corrosive locations and where subscript WP is indicated at the box location on the Drawings. Provide terminal blocks with a separate connection point for each conductor entering or leaving the box. Where 277-480V, 120-240V and/or <50V conductors enter the same terminal junction box, supply full depth 16-gauge metal dividers between the differing voltage terminals. Provide **25** percent spare terminal points for the DISTRICT’s use following completion of installation. Paint interior surfaces white for NEMA 1 or NEMA 12 boxes.

F. Wiring Devices

1. Switches:
 - a. General Use Switches: Provide specification grade, totally-enclosed, ac type, quiet tumbler switches meeting NEMA WD 1 performance standards and Federal Specification W-S-896F, and capable of control of 100 percent tungsten filament and fluorescent lamp loads. Provide switches rated at 20 A, 120/277 V. Provide operating handles colored white. Switches shall have screw terminals.
 - b. Weatherproof Switches: Provide switches mounted in a NEMA 4X PVC-coated cast metal box with gasketed, weatherproof device plate.

- c. Switches with Pilot Lights: Provide switches with a 125-volt neon light with red jewel, or lighted toggle which shall be lighted when the switch is on.
 - d. Manufacturers: Bryant, General Electric, Hubbell, Pass and Seymour, or equal.
2. Receptacles:
- a. Single and Duplex: Provide specification grade receptacles meeting NEMA WD 1 performance standards and Federal Specification W-C-596G, and having a contact arrangement such that contact shall be made on two sides of each inserted blade without detent. Provide two-pole, three-wire grounding type receptacles rated 20 A, 125 V, NEMA Configuration 5-20R, and with screw type wire terminals suitable for 10 AWG. Provide high-strength thermoplastic bases colored white. Manufacturers: Bryant, General Electric, Hubbell, Pass and Seymour, Sierra, or equal.
 - b. Weatherproof Receptacles: Receptacles shall be ground fault interrupter type as specified below, mounted in a PVC-coated cast metal box and enclosed with a polycarbonate weatherproof "in-use" cover. Manufacturers: Pass & Seymour, Hubbell, or equal.
 - c. Ground Fault Interrupter (GFI) Receptacles: Provide duplex specification grade GFI receptacles tripping at 5 mA; rated 20 A, 120 V, NEMA Configuration 5-20R; and capable of interrupting 1,000 A without damage. Provide units meeting NEMA WD 1, fitting standard sized outlet boxes, having 12 AWG copper TW insulated pigtails, having provision for testing, and white in color. Provide standard model where ground fault protection is needed at an individual location. Provide feed-thru model where ground fault protection is specified for "downstream" conventional receptacles. Provide receptacles accepting standard device plates. Manufacturers: Pass and Seymour, Square D, General Electric, or equal.
3. Device Plates:
- a. General:
 - (1) Provide plates fitting closely and tightly to the box on which they are to be installed.
 - (2) Provide plate material compatible with the box material such that galvanic corrosion of the plate and/or box does not occur.
 - b. Metal Plates: Provide specification grade, one-piece, 0.040-inch nominal thickness, No. 430 satin finish stainless steel device plates with oval-head, matching mounting screws.
 - c. Weatherproof (WP) Plates:
 - (1) Where weatherproof switches are designated, the switch shall be installed in the specified box with a gasketed, weatherproof, cast metal cover plate incorporating an external operator for the internal switch and with stainless steel mounting screws.
 - (2) Manufacturers and types: Crouse-Hinds DS-181 or DS-185, Appleton FSK-1VTS or FSK-1VS, or equal.

G. Retained Key Interlock:

1. When indicated in the Contract Documents, retained key interlocks shall be provided with each device such that the first device can be closed only after the second device is opened and vice versa. Retained key interlocks shall be Kirk Key, selected as needed to fit the installation.

H. Local Control Stations, Pushbuttons, Indicating Lights, and Selector Switches:

1. For general purpose dry locations, provide heavy-duty, 30 mm, and oil-tight type pushbuttons, indicating lights, and selector switches. Provide Allen-Bradley Type 800T, General Electric Type CR 104P, an equivalent by Square D, Cutler-Hammer, or equal.
2. For wet and corrosive locations, provide heavy-duty, 30 mm, and corrosion-resistant, watertight type pushbuttons, indicating lights, and selector switches mounted in NEMA 4X, Type 316 stainless steel watertight enclosures. Provide Square D Type SK, an equivalent by General Electric, Cutler-Hammer, Allen-Bradley or equal.
3. Install provisions for pushbuttons and selector switches pad-lockable in the OFF position wherever lockout provisions are indicated on the Contract Documents. Latch material shall be Type 316 stainless steel.
4. For wet, corrosive, and hazardous locations, local control station enclosures for push buttons, indicating lights and selector switches shall be listed for classified areas and shall be in compliance with NEC Article 500.
5. Provide selector switches having standard operating levers.
6. Indicating lights shall be heavy-duty, 30 mm, and oil-tight (NEMA 13) for indoors and water tight (NEMA 4X) for outdoors. Indicating lights for 120 V ac applications shall be 120 V ac, push-to-test, LED, transformer type. Indicating lights for 125 V dc applications shall be 125 V dc, push-to-test, LED type. Each light shall have a screwed-on plastic prismatic lens approximately 1 inch in diameter. Each light shall have a factory-engraved legend plate, as shown on the Contract Documents. Indicating lights shall be General Electric Type CR104, Square D Class 9001 Type SK and K, [Allen-Bradley 800T and 800H series](#), or equal.
7. Emergency stop pushbuttons shall have a large, red mushroom head, maintained contacts, push-to-stop, pull-to-reset, [Allen-Bradley Bulletin 800T](#), General Electric CR104P, or equal.

I. Terminal Blocks 600 V and less

1. Provide 600 V terminal blocks for termination of all power and 120 V control circuits entering or leaving electrical equipment, panels, and/or boxes. Provide screw clamp compression, dead front barrier type terminal blocks. For instrumentation and control terminal blocks, they shall be DIN-rail mounted, molded plastic with barriers and box lug terminals, and shall be rated 15 amperes at 600-volts. White marking strips, fastened securely to the molded sections, shall be provided and wire numbers or circuit identifications shall be marked thereon with permanent marking fluid. Terminal blocks shall be Allen-Bradley, Weidmuller, General Electric Type CR 151A1 with mounting rack, Cinch-Jones, Phoenix Contact type UK 5 N, or equal.

2. Size all terminal block components to allow insertion of all necessary wire sizes and types. Supply terminal blocks with marking system allowing the use of preprinted or field-marked tags. Supply CSA-certified or UL-listed terminal blocks manufactured by Allen-Bradley, Weidmuller, Ideal, Electrovert, or equal. Provide terminal blocks with 25 percent spare termination points for the DISTRICT's use following completion of installation.

J. Control Relays

1. Open frame industrial relays shall not be used unless accepted by the DISTRICT. Provide magnetic control relays with operating coils of the proper voltage rating as required by the control circuit, NEMA Class A600 (600V, 10A continuous, 7,200VA make, 720VA break), industrial control type with field convertible contacts, and meeting the requirements of NEMA ICS 2. Provide Allen-Bradley, Cutler-Hammer Type M-600, General Electric Type CR120B, or equal.
2. Where time delay relays are specified or required provide magnetic control relays with an electronic timer adjustable over the range specified on the Drawings.
3. Where latching (mechanically held) relays or motor thermal detector relays are specified, provide magnetic control relays with mechanical latch attachment with unlatching coil and coil clearing contacts. Provide an attachment allowing easy manual latching and unlatching.
4. Intrinsically safe relays shall allow the use of remote devices located in Class 1 (hazardous) locations by providing a circuit incapable of releasing sufficient electrical energy to ignite gases or vapors. The units shall have an output relay with 1 PDT per channel rated at least 2A at 120VAC, resistive load. The intrinsically safe relays shall be Allen-Bradley, Phoenix Contact PI-EX-ME-2NAM, Pepperl+Fuchs KHA5-SS1/EX2 or equal.
5. General Purpose Relays: General purpose relays in the Control Boards shall be plug-in type with 2DPDT contacts rated 10 amperes at 120 volts ac. Each relay shall be enclosed in a clear plastic heat and shock resistant dust cover. Relays shall be held in place with manufacturers relay retention hardware. Sockets for relays shall have screw type terminals. Relays shall be Allen-Bradley, Potter and Brumfield Type KRP or KUP, Square D Type KP, or equal.

K. Elapsed Time Meters

1. Provide synchronous-motor-driven or electronic, elapsed time meters, 0 to 99,999.9 hours range, non-reset type, suitable for semiflush, panel mounting. Provide meters by General Electric, Eagle Signal, or equal.

L. Magnetic Contactors

1. Provide contactors of the NEMA sizes indicated. Mount contactors in NEMA 12 enclosures unless otherwise indicated. Provide contactors manufactured and rated in accordance with NEMA ICS 2.

M. Dry Type Power Transformers

1. Provide self-cooled, two-winding, dry type transformers of the ratings indicated and built in accordance with the latest IEEE, ANSI, and NEMA standards. Provide units with manufacturer's standard insulation class and not to exceed 115 degrees C temperature rise.
2. Manufacturers: General Electric, Square D, Cutler-Hammer, or equal.

N. Main, Branch and Combination Breakers

1. Rating
 - a. Service: Service shall be 480 volt, 3 phase, 3 wire, 60 Hertz.
 - b. The overall short circuit withstand and interrupt rating of the equipment and devices shall be not less than 65,000 Amperes R.M.S. symmetrical at 480 volts. Main and feeder circuit protective devices shall be fully rated for the specified short circuit duty. Systems employing series connected ratings for main and feeder devices shall not be used. Motor starter units shall be tested and UL labeled for the specified short circuit duty in combination with the motor branch circuit protective device.
 - c. The continuous current rating of the main horizontal bus shall be as shown on the drawing. Vertical buses shall be sized for the structure load and shall have a minimum rating of 300 amperes. Bus bracing shall equal or exceed the specified equipment short circuit rating.
 - d. All devices shall be designed for continuous operation at rated current in a 40° C ambient temperature.
2. Components
 - a. General
 - (1) The drawings indicate the approximate horsepower and intended control scheme of the motor driven equipment. Provide the NEMA size starter, circuit breaker trip ratings, control power transformers and thermal overload heater element ratings matched to the motors and control equipment actually supplied, in compliance with the NEC and the manufacturer's heater selection tables. All variations necessary to accommodate the motors and controls as actually furnished shall be made without extra cost to the DISTRICT.
 - b. Main Circuit Breakers
 - (1) Molded case circuit breakers: 600 volt, 3 pole, 100% rated, with integral fully adjustable solid-state trip device. Provide external operating handles padlockable in the off position. Trip device shall be temperature insensitive and have the following characteristics and functions:
 - (a) Independently adjustable long time pick-up and delay.
 - (b) Independently adjustable short time pick-up and delay with in and out switch.
 - (c) Independently adjustable ground fault pick-up and delay.
 - (d) Trip mode targets for over load, short circuit and ground fault.
 - (e) Long time pick-up light.

- c. Branch Circuit Feeder Breakers (Non-motor loads)
 - (1) Molded case circuit breakers: Thermal-magnetic trip type, 600-volt, 2- or 3-pole as required, labeled in accordance with UL 489. Provide external operating handles padlockable in the off position. Circuit breakers shall be fully rated to meet the specified equipment short circuit rating. Provide independently adjustable magnetic trips on 250A frame breakers and larger.
- d. Combination Starter Units
 - (1) Combination starters shall include a motor circuit protector (MCP) in series with a motor controller and an overload protective device. The MCP shall have an adjustable magnetic trip range up to 1,000 percent of rated continuous current and a trip test feature. Provide external operating handles padlockable in the off position. MCPs shall be labeled in accordance with UL 489.
 - (2) Motor starters shall be 3-pole, 600-volt, electrically operated, of the types shown on the drawings. Provide NEMA sizes as required for the horsepower shown on the drawings. Minimum size shall be NEMA Size 1. Fractional size starters are not acceptable. Starters shall have 120-volt encapsulated operating coils; individual control power transformers with primary and secondary fuses and silver cadmium oxide renewable line contacts.
 - (3) Integral self-protected combination motor starter, where indicated on the plans, shall combine all the functions of a disconnect, circuit breaker, contactor, and overload relay in a coordinated modular unit and shall be UL listed as a Type E combination motor controller, meeting “Type 2” coordination protection per IEC 947-2. The entire assembly shall meet “Total Coordination” requirements of IEC 947-6 and be UL listed with a short circuit withstand rating of at least 30KAIC. Provide operating handles padlockable in the off position.
 - (4) Contactors: Electrically held, 120 VAC coil operator, suitable for tungsten, ballast, or resistive non-motor loads, with overcurrent protection, control transformer and contact ratings and poles as shown on the drawings.
 - (5) Motor overload protection: Ambient compensated, adjustable, 3 pole, thermal bi-metallic type, with push-to-test feature. Overload relays for submersible pump motors shall be ambient compensated, quick trip, Class 10. Overload relays shall be manually reset from outside the enclosure by means of an insulated pushbutton. Provide two, Form C auxiliary alarm contacts for each motor.
 - (6) Auxiliary contacts: Form C, NEMA A600 rating, as required by the control schemes developed by the Contractor. Provide 1-normally open and 1-normally closed spare contacts on each starter. Additional auxiliary contacts shall be furnished as required by the schematic diagram and specifications.
 - (7) Each motor control starter shall include the operating components shown on the schematic diagram.

- 3. Factory Testing and Inspection
 - a. Perform manufacturers standard production testing and inspection in accordance with NEMA, NETA and ANSI standards. The Contractor shall provide a 5-working day advance notice of factory testing in California and 3-week advance notice of factory testing outside California. All tests shall be performed in the presence of the DISTRICT.

O. Enclosure Paint and Finish

- 1. All metallic enclosures, except for stainless steel, shall be painted in accordance with manufacturer’s standard. Exterior color shall be ANSI No. 61. See Specification 09900.

PART 3 - EXECUTION

A. Outlet and Device Boxes

- 1. Installation:
 - a. Mount boxes at the following heights unless otherwise required by Americans with Disabilities Act (ADA), (heights shall be to the centerline of the box):

Wall switches and receptacles:	48 inches above floor
Thermostats:	54 inches above floor
Wall telephone outlets:	6 inches above counter tops; about 18 inches above floor
Wall mounted telephone:	52 inches above floor
Office, Lab Receptacles:	Flush device plate bottom or side with top of the backsplash on use areas, halls, etc. or 6 inches above counter tops without backsplash; about 18 inches above floor.

Where above heights do not suit the building construction or finish, locate boxes where directed by the DISTRICT.

Locations indicated are approximate. Study the Drawings in relation to spaces and equipment surrounding each outlet. When necessary, with the acceptance by the DISTRICT, relocate outlets to avoid interference with mechanical equipment and/or structural features. Locate all light switches on lock side of doors. Locate all light fixture outlets in a symmetrical pattern according to the room layout unless otherwise indicated.

Mount all boxes plumb and level. Provide flush-mounted boxes with concealed conduits. Make edges of boxes flush with finished surface. Provide proper type extension rings or plaster covers for this purpose. For flush-mounted boxes, make holes in the surrounding surface no larger than required to receive the box.

Install boxes in a secure, substantial manner supported independently of conduit by attaching to the building structure or a structural member. Fasten boxes with bolts and expansion anchors on concrete or brick, toggle bolts on hollow masonry units, and machine screws or welded, threaded studs on steelwork. No powder actuated tools shall be permissible. Boxes embedded in concrete or masonry need not be additionally supported. Provide galvanized

mounting hardware for general purpose dry locations and Type 316 stainless steel mounting hardware in wet and corrosive areas.

Provide flush or recessed lighting fixtures with separate junction boxes when required by the fixture terminal temperature. Where boxes support fixtures, provide proper means of attachment with adequate strength.

Seal all unused openings in any type of boxes.

B. Junction and Pull Boxes

1. Where indicated on the Drawings, and where necessary to terminate, tap-off, or redirect multiple conduit runs, provide and install appropriately designed junction boxes. Furnish and install pull boxes where necessary in the raceway system to facilitate conductor installation. Provide pull boxes to limit conduit runs to less than 150 feet and to contain no more than the equivalent of three right-angle bends unless accepted by the DISTRICT.

- a. Types to be provided:

Provide boxes of the types listed for specific locations as described above in Article entitled "Outlet and Device Boxes" of this Specification.

Provide outlet boxes as junction boxes and pull boxes wherever possible and allowed by applicable codes.

- b. Installation:

Make all boxes accessible. Do not install boxes in finished areas unless accepted by the DISTRICT. Mount all boxes plumb and level. Provide flush-mounted boxes with concealed conduits. Make edges of recessed boxes flush with the final surface.

Mount boxes in a secure, substantial manner supported independently of conduit by attachment to the building structure or a structural member. Fasten boxes with bolts and expansion shields on concrete or brick, toggle bolts on hollow masonry units, and machine screws or welded, threaded studs on steelwork. No power actuated tools shall be allowed. Threaded studs driven in by a powder charge and provided with lock washers and nuts shall be acceptable in lieu of expansion shields. Boxes embedded in concrete or masonry need not be additionally supported. Provide galvanized mounting hardware in general purpose dry locations and Type 316 stainless steel mounting hardware in wet and corrosive areas.

Install boxes for conduits under grade flush with finished grade in locations outside of paved areas, roadways, and walkways.

If adjacent structure is available, the box may be mounted on the structure surface just above finished grade in accessible but unobtrusive location. If it is found desirable to locate boxes in paved areas, roadways, or walkways, obtain the DISTRICT's written acceptance and provide boxes and covers suitable for the weights to which they may be subjected.

C. Terminal Junction Boxes

Install in accordance with all the requirements detailed herein. Label each block and terminal with a permanently attached, non-destructible tag.

D. Wiring Devices

1. Switches: Mount switches in the vertical position.
2. Receptacles: Mount receptacles with grounding slot down, except where horizontal mounting is indicated, in which case mount with neutral slot down. Ground receptacles to boxes with grounding wire, not by yoke or screw contact.
3. Device Plates: Securely fasten device plates to the respective switch and receptacle boxes, and the wiring devices. Install device plates used with flush-mounted boxes with all four edges in continuous contact with the finished wall surfaces without the use of mats and/or similar materials. Plaster fillings shall not be acceptable. Install device plates with an alignment tolerance of 1/16 inch. Do not use sectional type device plates.

E. Dry Type Transformers

1. Mount transformers approximately where indicated. Install vibration isolators to provide complete isolation with no direct transformer unit metal in contact with the mounting surface. Provide liquid-tight flexible conduit to prevent transformer vibrations from transmitting to the building and/or other equipment.
2. Ground neutrals, enclosures, and liquid-tight flexible conduits in accordance with applicable codes. Connect voltage taps on all transformers to give as close as possible to rated output voltage under normal plant load conditions.

END OF SECTION

SECTION 16060

GROUNDING AND BONDING

PART 1 - GENERAL

A. The Requirement

1. The CONTRACTOR shall furnish all tools, equipment, materials, and supplies and shall perform all labor required to complete the Work as indicated on the drawings and specified herein.
2. Electrical grounding and bonding systems shall be installed as indicated herein and/or elsewhere in the Contract Documents with materials including, but not limited to, cables/wires, connectors, solderless lug terminals, grounding electrodes and plate electrodes, bonding jumper braid, exothermic connections, and additional accessories needed for a complete installation. Where materials or components are not indicated, provide products which comply with NEC, UL, and IEEE requirements and with established industry standards.
3. System ground conductors shall run continuously in duct banks and cable trays, through manholes, handholes, and other raceways. The system ground conductor shall be connected to the structure grounding systems to provide a continuous ground system.
4. Existing grounding conductors shall be rerouted to new equipment where feasible. Existing grounding conductors shall be removed to 2" below concrete finish level and the concrete shall be patched where the conductors are abandoned.

B. Related Work Specified Elsewhere

1. The requirements of the following divisions and sections apply to the Work of this section. Other divisions and sections of the Specifications, not referenced below, shall also apply to the extent required for proper performance of this Work.

Electrical, applicable sections

Division 16

2. Materials, equipment and devices furnished and installed under Divisions with raceway and electrical conductors furnished, installed, and connected under Division 16, Electrical.

C. Referenced Specifications, Codes and Standards

1. All Work specified herein shall conform to or exceed the applicable requirements of the referenced portions of the following publications to the extent that the provisions thereof are not in conflict with other provisions of these specifications.
2. Comply with the current editions of the following codes and standards.
 - a. Codes and Standards
NEC: National Fire Protection Association (NFPA) – 70 National Electrical Code (NEC)

CCR: Title 8, Industrial Relations, Subchapter 5, Electrical Safety Orders, California Code of Regulations

b. Commercial Standards

ANSI/IEEE 80: Guide for Safety in AC Substation Grounding

ANSI/UL 467: Safety Standard for Grounding and Bonding Equipment

IEEE 142: Grounding of Industrial and Commercial Power Systems

3. All equipment furnished by the contractor shall be listed by and shall bear the label of Underwriters' Laboratories, Incorporated, (UL) or of an independent testing laboratory acceptable to the engineer in writing.
4. The construction and installation of all electrical equipment and materials shall comply with all applicable provisions of the CAL-OSHA Safety orders. (Title 8 CCR, as applicable), State Building Standards, and applicable local codes and regulations.

D. Contractor Submittals

1. Submittals shall be made in accordance with the requirements of Section 16010 Electrical General Provisions and Section 01330 Submittals.
2. General Provisions - Submittals shall conform to the requirements of Section 16080 Electrical Testing, Section 16120 Conductors and Cables, and additional requirements specified herein. Submittals shall be made for, but not be limited to the following:
 - a. Catalog literature for all products.
 - b. Certified copies of ground test results.
 - c. Field test procedures including lists of test equipment to be used.

E. Quality Assurance

1. Quality assurance shall be in accordance with the requirements of Section 16010 Electrical General Provisions and Section 16080 Electrical Testing.

PART 2 - PRODUCTS

A. Grounding Conductors

1. CONTRACTOR shall locate existing grounding conductors and shall spliced as needed and extended to the new panels, conduits and other equipment shown ground on the drawings. All grounding conductors furnished shall be composed of material resistant to existing corrosive conditions or shall be suitably protected against such conditions.
2. Protect all grounding conductors from physical damage in accordance with NEC requirements. Where grounding conductors rise above ground, install Schedule 80 PVC sleeves to protect the grounding conductors.

B. Grounding Connections

1. For above grade connections, provide mechanical or compression connectors.

2. Where equipment bases are shown with grounding conductors, attach the grounding conductor to manufacturer-provided grounding points in accordance with manufacturer's instructions. Where there are no manufacturer's provisions for grounding the equipment base, weld a screw-type grounding connector suitable for stranded copper conductors to the base to receive the grounding conductor.

PART 3 - EXECUTION

A. General

1. All conductor to conductor grounding connections shall be by means of exothermic welded connections (inaccessible locations) or compression connectors (accessible locations).
2. The contractor shall connect together service equipment enclosures via separate grounding conductors, exposed non-current carrying metal parts of electrical equipment, metal raceway systems, grounding conductor in raceways and cables, receptacle ground connectors, and plumbing systems as required by the National Electrical Code.
3. Unless otherwise indicated on the Contract Documents, the contractor shall provide electrical grounding conductors for grounding system connections that match power supply overcurrent protection and are sized according to NEC. All equipment grounding conductors shall consist of a separate insulated equipment grounding conductor run in the conduit or multiconductor cable from the equipment to the MCC, panelboard, switchgear, etc. equipment ground bus.
4. The contractor shall terminate feeder and branch circuit insulated equipment-grounding conductors with grounding lug, or bushing.
5. The contractor shall connect together metal raceway systems, cable tray systems, and grounding conductors in raceways and cables, as required by the National Electrical Code. The cable tray ground cable shall be sized for the largest circuit breaker serving the cable tray system.
6. The contractor shall tighten grounding and bonding connectors and terminals, including screws and bolts, to the manufacturers recommended torque values. Where manufacturer's torque values do not exist, comply with torque values specified in UL 486A.
7. Ground connection to equipment and ground buses shall use ground lugs compatible with copper. Connections to enclosures not provided with ground buses or ground terminals shall be by clamp type lugs added under permanent assembly bolts or under new bolts drilled and added through enclosures other than explosion proof, or by grounding locknuts or bushings. Explosion proof enclosures not provided with any of the above grounding means shall be grounded by the addition of an adjacent junction box with a ground lug. Ground cable connections to anchor bolts, against gaskets, paint, or varnish, or on bolts holding removable access covers will not be permitted.
8. Ground cable penetrations through building exterior walls shall enter within 3 feet below finish grade and shall be prepared with a water stop. Unless otherwise indicated in the Contract Documents, the water stop shall include filling the space between the strands with solder and soldering a 12-inch copper disc over the cable.
9. All ground connection hardware, bolts, and nuts shall be high strength, high conductivity copper alloy.

10. Liquid tight flexible conduits shall be provided with separate equipment grounding conductors sized in accordance with the NEC. The equipment grounding conductor shall be bonded to an accepted grounding bushing and terminal lug. The grounding conductor may be installed outside the conduit if the required size is greater than # 10 AWG.
11. Exposed splices and connections for bare copper conductors and buses shall be protected by wrapping with heat shrink tape or covering.

B. Grounding Connections

1. When making exothermic welds, wire brush or file the point of contact to a bare metal surface. Use exothermic welding cartridges and molds in accordance with the manufacturer's recommendations. After welds have been made and cooled, brush slag from the weld area and thoroughly clean the joint.
2. Use connectors of proper size for conductors and ground rods specified. Use connector manufacturer's compression tool. Notify the DISTRICT prior to backfilling any ground connections.

C. Field Tests

1. The grounding system modifications shall be tested as specified in Section 16080.

END OF SECTION

SECTION 16075

ELECTRICAL IDENTIFICATION NAMEPLATES AND WARNING SIGNS

PART 1 - GENERAL

A. The Requirement

The Contractor shall furnish all tools, equipment, material, and supplies and perform all labor required to install nameplates and/or warning signs to identify electrical equipment as indicated on the Drawings and specified herein.

B. Related Work Specified Elsewhere

The requirements of the following sections and divisions apply to the Work of this section. Other sections and divisions of the Specifications, not referenced below, shall also apply to the extent required for proper performance of this Work.

1. Section 16120, Conductors and Cables
2. Section 16130, Raceway Systems and Pull Boxes
3. Division 16, Electrical, other applicable sections

C. Reference Specifications, Codes and Standards

1. All Work specified herein shall conform to or exceed the applicable requirements of the referenced portions of the following publications to the extent that the provisions thereof are not in conflict with other provisions of these Specifications.
2. Comply with the applicable editions of the following codes, regulations, and standards:
 - a. Codes and Regulations:

29 CFR 1910	Code of Federal Regulations, Title 29, Part 1910, U.S. Occupational Safety and Health Standards (OSHA)
CCR	California Code of Regulations, Title 8, Div. 1, Chap. 4, Subchap. 5, Electrical Safety Orders
CCR	California Code of Regulations, Title 8, Industrial Relations (Cal/OSHA), other applicable provisions
NFPA 70	National Electrical Code (NEC)
 - b. Industry Standard:

IEEE C37.2	Electrical Power System Device Function Numbers, Acronyms, and Contact Designations
------------	---
 - c. Comply with the applicable reference Specifications as specified in the General Requirements and the Addition General Requirements.

PART 2 - PRODUCTS

A. Nameplates and Warning Signs

1. Nameplates: Nameplates for indoor electrical equipment shall be black lamicoïd with white letters. They shall be fastened with round head stainless screws. Nameplate for outdoor electrical equipment shall be engraved or laser etched Type 316 stainless steel and fastened with General Electric (GE) Silicone II sealant or equal. At locations where fastening the nameplate with screw is not practical (such as behind front door of equipment or explosion-proof enclosure), use GE Silicone II Sealant or equal.
 - a. Any equipment for which a nameplate is required, but not shown on the Contract Documents, the Contractor shall request in writing such nameplate legend from the DISTRICT.
 - b. The nameplates shall be installed on the front and back of the enclosure (if backside access is available) to clearly identify each compartment, power source, etc. This shall apply to all equipment installed and/or modified per the Contract Documents.
 - c. All control panels and terminal board panels shall have large equipment nameplates with 3/4-inch-high letters for the panel designation, and nameplates with 3/16-inch-high letters for each control and indicating device in accordance with the Contract Documents.
 - d. Visible, permanent engraved nameplates shall be provided by Contractor identifying each instrument, relay, switch, indicating light, circuit breaker compartment, potential transformer compartment, fuse block, and auxiliary compartment. Devices mounted inside the compartment shall also be identified with engraved nameplates. Equipment and terminal blocks within control panels, boxes and compartments shall be permanently identified with engraved nameplates. This shall include the backside of door- or panel-mounted items. The backside engraved nameplate shall read the same as the front engraved nameplate. Protective relays shall be designated as to use, the phase to which connected and shall include the IEEE C37.2 device function number; e.g., Phase A Overcurrent Relay, Device 51.
 - e. All pilot device legend plates, whether located on MCC compartment door, control panels, or as part of field control stations, shall receive legend plates made of lamicoïd material (indoors) or stainless steel (outdoors), mounted above the pilot device with minimum two-line identification. First line shall indicate the function description, such as ON, OFF, RESET, etc.
 - f. Warning Signs: All warning signs shall be in accordance with OSHA regulations and shall be suitable for exterior use when installed outdoors. The warning signs shall be fastened with methods described above. All warning signs shall be 7 inches high by 10 inches wide unless otherwise noted in the Contract Documents, and on 1/16-inch thick plastic or similar material acceptable to the DISTRICT. The signs specified below shall be installed on the front and back of the enclosure (if backside access is available to the enclosure) of each electrical distribution equipment and control equipment to clearly identify each compartment, power source, etc. This shall apply to all equipment installed and/or modified per the Contract Documents.

- (1) Permanent and conspicuous warning signs shall be mounted on all equipment, doorways to equipment rooms, pull boxes, manholes, etc. where the operating voltage exceeds 600 V. High-voltage warning signs shall be colored red with white lettering and shall read:

DANGER
xxx VOLTS
KEEP OUT

- (2) Rear access panels or doors of cubicles containing power conductors shall include a large "DANGER xxx VOLTS INSIDE" nameplate of red background and 1-inch high minimum white lettering.
- (3) A door-mounted sign made of laminated plastic with white letters on a red background shall be provided on each compartment in which multiple voltage sources will be terminated. The sign shall read: "**Caution - This Unit Contains Foreign Voltage Sources.**"
- (4) Permanent warning signs shall be mounted at all mechanical equipment which can be started automatically or be started from remote locations. Automatic or remote controlled equipment warning signs shall be colored yellow with black lettering and shall read:

**CAUTION
THIS EQUIPMENT STARTS
AUTOMATICALLY OR
BY REMOTE CONTROL**

B. Conduit, Multiconductor Cable, and Conductor Identification

1. Conduit Tags

- a. Conduits shall be tagged at all terminations and every 50 feet along the exposed conduit route. Conduits shall also be tagged where the conduits and/or conductors enter an underground installation and/or penetrate a wall. The conduit numbering systems shall provide for the unique designation of each conduit and tray as shown in the Contract Documents.
- b. Use the conduit number as shown on the construction drawings.
- c. Conduit marker tags shall be 2-inch minimum diameter, 0.036-inch minimum thickness, Type 316 stainless steel, with a single hole. Tags shall be attached to the conduits with 0.03-inch Type 316 stainless steel wire. The conduit numbers and tray segment numbers shall be engraved or laser-etched in 3/16-inch minimum height characters
- d. Color Coding: Power conductors shall be color coded at the terminations in accordance with Specification Section 16120, Conductors and Cables. In addition, single power conductors of a three-phase circuit shall be color coded or tagged Phase A, B, and C at each manhole, handhole, and pull-box.
- e. All exposed conduits with conductors rated 480 V and above shall also be identified with markers in accordance with Specification section 16130, Raceway Systems and Pull Boxes.

2. Conductor and Multiconductor Cable Tags:

- a. Each conductor and multiconductor cable shall be identified with tags at each termination. The tag number shall be the same at each end. In addition, conductors and multiconductor cable shall be tagged at least once in pull boxes, junction boxes, manholes, maintenance holes, handholes.
- b. Multiconductor cables shall be tagged at all jacket end points.
- c. Each conductor of a multiconductor cable shall be individually tagged.
- d. Each multiconductor cable and conductor shall be identified with a white shrink-on wire marker sleeve acceptable to the DISTRICT. The wire sleeve should only be slightly shrunk to keep the tubing from slipping down the cable/conductor but loose enough to allow the wire tag to be rotated after it is installed so it can be made more readable. The sleeves shall be as manufactured by Brady, Thomas and Betts, or equal.
- e. Tags relying on adhesives or taped-on markers shall not be acceptable.

3. Conductor Tag:

- a. Each Conductor Tag shall be two lines. The tag shall be identical at both ends of conductor and shall specify the "FROM" and "TO" terminations of each conductor as follows:

Equipment Identifier-Terminal Block Designation-Terminal No. Equipment Identifier-Terminal Block Designation-Terminal No.
--

- b. Equipment Identifier shall be as follows:
 For Control Panels: the Panel Tag Number (PTN) shall be used.
 For Field Instruments: the Loop Tag Number (LTN) shall be used.
 For Electrical Distribution Equipment: the Single-Line Designation of the equipment shall be used.

Examples of Equipment Identifier:
 Control Panel PCP, CP
 Field Equipment LIT, LSH

- c. Example:

LIT-TB1-1 LCP-TB6-3

- d. Do not list terminal block number if a device does not have a terminal block number.

- e. Examples:

LIT- (+) PCP-D2S10-1

- f. Multiconductor Cable Tag:

- (1) Each multiconductor cable tag shall be one lines.
- (2) The top line of the tag specifies the "FROM" and "TO" destinations as found in the Conduit/Cable Schedule and in accordance with the following

example: PCP-PTA, where PCP is the “From” destination separated by a hyphen from ATS, the “To” destination.

- (3) Example:

PCP-ATS

- (4) Each individual conductor in the multiconductor cable shall be labeled as shown above in Conductor Tag.

4. Color Coding:

- a. Power conductors shall be color coded at the terminations in accordance with Specification section 16120, Conductors and Cables. In addition, single power conductors of a three-phase circuit shall be color coded or tagged Phase A, B, and C at each manhole, handhole, and pull-box.

PART 3 - EXECUTION

A. General

1. The Contractor shall coordinate the installation of electrical equipment so all equipment, conduits, cable trays, cables, and conductors are identified in accordance with these Specifications.
2. The Contractor shall provide an Excel spreadsheet at the conclusion of the project with the assigned cable and conduit tag numbers, FROM location, TO location, and description.

END OF SECTION

SECTION 16080

ELECTRICAL TESTING

PART 1 - GENERAL

A. The Requirement

1. This Section defines electrical equipment testing responsibilities for the Contractor.
2. Tests specified herein that do not require the use of the testing organization may be performed by the Contractor.
3. The Contractor shall furnish all tools, equipment, material, and supplies and perform all labor required to perform electrical tests as indicated on the Contact Documents and specified herein.
4. The Contractor shall include electrical testing in the construction schedule.

B. Related Work Specified Elsewhere

The requirements of the following sections and divisions apply to the work of this Section. Other sections and divisions, not referenced below, shall also apply to the extent required for proper performance of this work.

1. Division 16, Electrical, applicable sections

C. Reference Specifications, Codes and Standards

1. All work specified herein shall conform to or exceed the applicable requirements of the referenced portions of the following publications to the extent that the provisions thereof are not in conflict with other provisions of these Specifications.
2. Comply with the applicable editions of the following codes, regulations, and standards:
 - a. Codes and Standards
 - 29 CFR 1910: Code of Federal Regulations, Title 29, Part 1910, U.S. Occupational Safety and Health Standards (OSHA)
 - CCR: California Code of Regulations, Title 8, Div. 1, Chap. 4, Subchap. 5, Electrical Safety Orders
 - NFPA 70: National Electrical Code (NEC)
 - NFPA 70E: Standard for Electrical Safety in the Workplace
 - b. Industry Standards
 - IEEE 43: Recommended Practice for Testing Insulation Resistance of Rotating Machinery
 - NETA: Standard for Certification of Electrical Testing Technicians
 - NETA: Standard for Acceptance Testing Specifications

- c. Other Standards
 - ANSI: American National Standards Institute
 - IEEE: Institute of Electrical and Electronics Engineers
 - NEMA: National Electrical Manufacturers Association
 - NETA International Electrical Testing Association
 - NFPA: National Fire Protection Association
 - NIST: National Institute of Standards and Technology

- 3. Comply with the applicable reference Specifications as directed in the General Requirements and Additional General Requirements.

D. Submittals

- 1. Submittals shall be made in accordance with the General Requirements, Additional General Requirements and as specified herein.
- 2. Testing Plan
 - a. The Contractor shall submit for Engineer's acceptance a testing plan for each electrical item. Equipment tested by the testing organization and equipment tested by the Contractor's testing personnel shall be included in Testing Plan.
 - b. The testing plan shall detail the type, schedule and duration of each test. The testing plan shall, as a minimum, include a description of test, identify tools required, construction power required, the state of installation of the equipment to be tested, and any safety issues.
- 3. Test Reports: Three bound copies of the certified test reports shall be submitted to the Engineer at the completion each test. The final report shall be signed and shall include the following information:
 - a. Summary of the project
 - b. Description of equipment tested and the DISTRICT Tag Number
 - c. Visual inspection report
 - d. Description of tests
 - e. Test results
 - f. Conclusions and recommendations
 - g. Appendix including appropriate test forms
 - h. Identification of test equipment used
 - i. Device setting values
 - j. Tester's name and date of test

4. Protective Device Setpoint and Arc Flash Request
 - a. The Contractor shall request from the Engineer the adjustable/programmable protective device settings and available arc flash hazard information after all applicable electrical equipment submittals have been accepted.
 - b. The submittal shall request all adjustable/programmable settings for each piece of equipment including settings for time, current, voltage, frequency, power factor, ground detection, transformer tap, etc.
 - c. The submittal shall be in each respective equipment manufacturer's format and each set point shall be included.

E. Quality Assurance

1. General: Comply with the requirements specified herein and the applicable reference Specifications of the General Requirements and Additional General Requirements.
2. Test Instrumentation
 - a. The testing organization and Contractor shall have a calibration program that ensures that all applicable test instruments are maintained within rated accuracy. The accuracy shall be directly traceable to NIST Standards. Dated calibration labels shall be visible on all test equipment, and up to date records and calibration instructions shall be maintained for each test instrument. The calibrating standard shall be of a higher accuracy than that of the instrument tested.
 - b. All testing shall be done using the proper test equipment. Megohmmeters, ohmmeters, and dc high-potential test sets from such manufacturers as Biddle, Associated Research, Hipotronics, and AEMC shall be acceptable for use in performing insulation resistance and high-potential tests.
3. Testing Organization
 - a. The testing organization shall be provided by the generator manufacturer.
 - b. The testing organization shall use technicians who are certified and regularly employed for testing services.
 - c. Technicians performing electrical tests and inspections shall be trained and experienced concerning the apparatus and systems being evaluated.

PART 2 – PRODUCTS (NOT USED)

PART 3 - EXECUTION

A. General

1. Prior to testing equipment including cable, the equipment shall be installed and secured per the manufacturer's recommendations, the Contract Documents. A minimum of ten days in advance, the Contractor shall provide a notice to the Engineer for inspection of installation. Engineer's acceptance of installation shall be obtained prior to the commencement of any testing.
2. The Contractor shall update the testing schedule showing daily work projected a minimum of three weeks into the future.

3. The Contractor shall provide a minimum of seven days' notice to the Engineer for the scheduling of any testing.
4. The Contractor shall provide the testing organization-approved manufacturers' documentation of all equipment.
5. The Contractor, in the event a retest is required due to failure of equipment, adverse testing conditions, or method of installation, shall schedule the retest. Any impact to schedule shall be borne by the Contractor.
6. All tests that are required to be performed, whether done by the Contractor or by the testing organization shall be in accordance with NETA Standard for Acceptance Testing Specifications.
7. High-potential tests shall not be repeated without authorization by the Engineer.
8. Test and inspection records shall be submitted to the Engineer no later than thirty days after completion of the individual test and prior to energizing of equipment.
9. All tests shall be performed with the equipment or material de-energized, except where otherwise specifically required by the nature of the test.
10. All items not in conformance with the requirements of this Section shall be noted on an Electrical Punchlist Record for correction by the Contractor.
11. The Engineer may, during start-up and check-out of electrical equipment, perform additional testing functions, wiring check-out, operational compliance certification, etc. to satisfy that the equipment meets the Contract requirements. The Contractor shall be responsible for correcting deficiencies revealed by the testing.

B. Contractor Tests

1. Tests listed herein are to be performed by the Contractor's staff. The tests are not substitutions for tests required to be performed by the testing organization but are additional or complimentary tests.
2. Upon completion of various phases of the project, electrical equipment and wiring and cabling systems shall be inspected and tested in accordance with this Section. All testing shall be in accordance with the applicable ANSI, IEEE, NETA, NEMA, or other national standard, and in accordance with the specific manufacturer's instruction bulletins or other literature supplied with the equipment to be tested, and the test equipment manufacturer's operating instructions.
3. The Contractor shall check all equipment for proper mechanical adjustment and freedom of operation. All electrical equipment, both pre-wired and field-wired shall be field-tested for functional operation, including all intended modes and sequences of operation. This shall include switches, relays, non-adjustable circuit breakers, contactors, etc., including control interlock and sequence circuits. All necessary adjustments shall be made on apparatus in accordance with the manufacturer's instructions and design requirements. Alarm systems and circuits shall be tested by manually operating the initiating devices. Relays and control components that may prove to be functioning incorrectly or otherwise appear to be

unreliable shall be repaired or replaced as necessary. An electrical system will not be accepted until it is tested in its entirety and the results reported to and accepted by the Engineer.

4. Circuit and Cable Testing

a. Power, Control and Lighting Circuits - 600 V and Below. The Contractor shall perform continuity checks of all power, control and lighting cables and wires, including each conductor of multiconductor and multipair cables. Continuity checks shall be done prior to termination of cables and any testing organization tests.

- (1) The Contractor shall visually check all wire and cable connections, verify wire numbers, and verify that the actual wiring conforms to the Drawings.
- (2) Each power cable shall be tested to ensure proper phase identification.
- (3) The conductor ends shall be cleaned and guarded for personnel safety during testing. Circuits in the immediate vicinity that are not under test shall be grounded.
- (4) Prior to performing insulation resistance tests on cables, the Contractor shall verify that they are not connected to any solid state devices, transformers, or capacitors.
- (5) The Contractor shall perform insulation resistance tests on all 600 V power and control cables. Each conductor in a multiconductor or multipair cable or conduit shall be tested against ground with the conduit and/or all others conductors connected to ground. Motor feeder circuits shall be tested with motors disconnected and the controller open. Motor control circuits shall be tested with control stations and overcurrent devices connected. Lighting panelboard main feeder circuits, including lighting panelboard and transformer, shall be tested with the branch circuit breakers open. Testing shall be for one minute using 1000 V dc. Values of insulation resistance less than 50 megohms shall not be acceptable.
- (6) The Contractor shall check all ac and dc control circuits for short circuits and extraneous grounds.
- (7) The Contractor shall perform functional tests of all power, control and lighting circuits. Alarm conditions shall be simulated for each alarm and control point, and alarm indicators shall be checked for proper operation. All control circuits shall function as intended by the Contract Documents. Metering and indication lights for motors shall be checked for proper operation. All lighting panels, circuits and fixtures, power panels, circuits, and receptacles shall be tested for proper operation.
- (8) The Engineer shall be notified if minimum insulation resistance values are not obtained.

b. Instrumentation, Signal and Alarm Circuits - 300 V and Below.

- (1) The Contractor shall perform continuity checks of all instrumentation, signal and alarm cables and wires, including each conductor of multiconductor and multipair cables. Continuity checks shall be done prior to termination of cables.

- (2) The Contractor shall visually check all wire and cable connections, verify wire numbers, and verify that actual wiring conforms to the Drawings.
- (3) Prior to performing insulation resistance tests on cables, verify that they are not connected to any solid-state devices.
- (4) The Contractor shall perform insulation resistance tests on all instrumentation, signaling and alarm cables. Each conductor in a multiconductor or multipair cable or conduit shall be tested against ground with the conduit, shield and/or all other conductors connected to ground. Testing shall be for one minute using 500 V dc. Values of insulation resistance less than 50 megohms shall not be acceptable.
- (5) Alarm conditions shall be simulated for each alarm and control point, and alarm indicators checked for proper operation.
- (6) The Contractor shall check all ac and dc instrumentation, signaling and alarm circuits for short circuits and extraneous grounds.
- (7) The Engineer shall be notified if minimum insulation resistance values are not obtained.
- (8) The Contractor shall perform a functional test of all electrical signaling and alarm systems.

C. Tests Required to be Performed by Testing Organization

1. Prior to testing equipment including cable, the equipment shall be installed and secured per the manufacturer's recommendations and the Contract Documents. All terminations required for NETA testing shall be complete. A minimum of ten days in advance, the Contractor shall provide a notice to the Engineer for inspection of installation. Engineer's acceptance of installation shall be obtained prior to the commencement of any testing.
2. Subsequent to acceptance of installation by the Engineer, the Contractor shall provide a minimum of ten days' notice of third party testing. Energizing of tested equipment shall be at the discretion of the Engineer and will not take place until passed and documented by the testing organization and reviewed by the Engineer. The entire electrical system shall be tested before energization. If functional testing requires power, the Contractor shall provide temporary power for that purpose. All testing shall be completed prior to equipment start up.
3. All references to NETA in this Specification section are referring to NETA Standard for Acceptance Testing Specifications.
4. The following tests shall be performed by the testing organization and witnessed by the DISTRICT:
 - a. Switchgear and Switchboard Assemblies: Perform all inspection and tests, including all optional tests, listed in Section 7.1 of NETA on all Low-Voltage Switchgear and Low-Voltage Switchboard Assemblies.
 - b. Circuit Breakers, Air, Insulated-Case/Molded-Case: Perform all inspection and tests, including all optional tests, listed in Section 7.6.1.1 of NETA on all insulated-case/molded-case circuit breakers 100 A trip and higher.

- c. Circuit Breakers, Air, Low-Voltage Power: Perform all inspection and tests, including all optional tests, listed in Section 7.6.1.2 of NETA on all low-voltage power circuit breakers.
- d. Motor Control, Motor Starters, Low-Voltage: Perform all inspection and tests, including all optional tests, listed in Section 7.16.1.1 of NETA on all motor starters. For item 7.16.1.1.6 “Perform operational tests by initiating control devices,” the starter control devices (selector switches, pushbuttons, relays, pilot lights, etc.) and motor control wiring shall be tested by simulating field device controls or signals at starter terminal blocks to simulate actual control functionality.

D. Setting and Testing of Adjustable/Programmable Protective Devices

- 1. The Engineer will provide settings within thirty days after Contractor’s “Protective Device Setpoint and Arc Flash Request” and all protective device data/manual submittal.
- 2. The testing organization shall set/program and test the adjustable/programmable protective devices in the field according to applicable NETA and manufacturer’s requirements.

E. Short Circuit Coordination Study / ARC Flash Hazard Analysis

- 1. The Contractor shall provide a short-circuit analysis with protective device evaluation, a protective device coordination study, load flow/voltage drop analysis and an arc flash hazard analysis.
- 2. The results of the short-circuit, protective device coordination, and arc flash hazard analysis studies shall be summarized in a final report and shall include protective device time current coordination curves, one-line diagrams showing protective device ampere ratings, cable size and lengths, transformer kVA and voltage ratings, motor and generator kVA ratings, switchboard and panelboard designations.
- 3. The Contractor shall furnish an arc flash hazard analysis study performed in compliance with the latest edition of IEEE Standard 1584 – “IEEE Guide for Performing Arc Flash Hazard Calculations” and per NFPA 70E – “Standard for Electrical Safety in the Workplace” and submit for DISTRICT’s review and acceptance a minimum of sixty (60) days before the equipment is scheduled to be energized.
- 4. The arc flash hazard analysis shall include calculations that determine the arc flash incident energy levels and flash protection boundary distances.
- 5. The Contractor shall provide and install labels on the project electrical equipment for personnel protective clothing requirements to comply with arc flash hazard sign installation requirements as specified in NEC Article 110.16 “Flash Protection” and NFPA 70E. A black and white copy of the arc flash label template is attached herein. The Contractor shall obtain the template file (Microsoft Word format) from the DISTRICT and use the file to generate and print the labels in color.
- 6. Arc flash labels shall be installed at all the locations specified below:
 - a. One on each vertical section of the MCC.
 - b. One on each VFD if in standalone sections.

c. One on each section of power distribution centers.



F. Attachments

1. Attachment A - Arc Flash Label Template.



END OF SECTION

SECTION 16080 - ATTACHMENT A
 ARC FLASH LABEL EXAMPLE AND TEMPLATE

EXAMPLE

		 DANGER			
Flash & Shock Hazard with Covers or Doors Open Appropriate PPE Required					
Flash Protection			Shock Protection		
			Shock Hazard When Covers Removed or Doors Open		
Flash Hazard Category	2		Voltage	480	V ac
Incident Energy	3.1	cal/cm ²	Limited Approach Boundary	3.5	ft
Flash Protection Boundary	2.4	ft	Restricted Approach Boundary	1	ft
			Prohibited Approach Boundary	1	in.
Equipment:	55FATS126		Source Equipment Name:	DPN-A	
Equipment Name:	TS-DPN1		Source Protective Device:	Solid State Trip Device	
Contract #	5-50		Study Rev Date:	3-15-2011	

TEMPLATE

	<div style="background-color: red; color: white; padding: 5px; font-weight: bold; font-size: 24px;">  DANGER </div> <div style="background-color: black; color: white; padding: 5px; font-weight: bold; font-size: 14px;"> Flash & Shock Hazard with Covers or Doors Open Appropriate PPE Required </div>	
<p>Flash Protection</p> <p>Flash Hazard Category</p> <p>Incident Energy cal/cm²</p> <p>Flash Protection Boundary ft</p>	<p>Shock Protection</p> <p>Shock Hazard When Covers Removed or Doors Open</p> <p>Voltage V ac</p> <p>Limited Approach Boundary ft</p> <p>Restricted Approach Boundary ft</p> <p>Prohibited Approach Boundary in.</p>	
<p>Equipment:</p> <p>Equipment Name:</p> <p>Contract #</p>	<p>Source Equipment Name:</p> <p>Source Protective Device:</p> <p>Study Rev Date:</p>	

SECTION 16120

CONDUCTORS AND CABLES

PART 1 - GENERAL

A. The Requirement

1. The Contractor shall furnish all tools, equipment, material, and supplies and shall perform all labor required to complete the Work as indicated on the Drawings and specified herein.
2. The Contractor shall furnish and install power and control conductors and cables, as described herein and as indicated on the Contract Documents.

B. Related Work Specified Elsewhere

1. The requirements of the following sections and divisions apply to the Work of this section. Other sections and divisions of the Specifications, not referenced below, shall also apply to the extent required for proper performance of this Work.
 - a. Section 16050, Basic Materials and Methods
 - b. Section 16075, Electrical Identification Nameplates and Warning Signs
 - c. Section 16080, Electrical Testing
 - d. Section 16130, Raceway Systems and Pull Boxes
 - e. Division 16, Electrical, other applicable sections

C. Reference Specifications, Codes and Standards

1. All Work specified herein shall conform to or exceed the applicable requirements of the referenced portions of the following publications to the extent that the provisions thereof are not in conflict with other provisions of these Specifications.
2. Comply with the applicable editions of the following codes, regulations, and standards:
 - a. Codes and Regulations:

19 CFR 1910	Code of Federal Regulations, Title 29, Part 1910, U.S. Occupational Safety and Health Standards (OSHA)
CCR	California Code of Regulations, Title 8, Div. 1, Chap. 4, Subchap. 5, Electrical Safety Orders
CCR	California Code of Regulations, Title 24, Part 3, California Electrical Code
NFPA 70	National Electrical Code (NEC)
 - b. Industry Standards:

ASTM B8	Standard Specification for Concentric-Lay-Stranded Copper Conductors, Hard, Medium-Hard, or Soft
---------	--

MOULTON NIGUEL WATER DISTRICT

ICEA S-73-532/NEMA WC 57	Standard for Control, Thermocouple Extension, and Instrumentation Cables
ICEA S-81-570	Standard for 600 Volt Rated Cables of Ruggedized Design for Direct Burial Installations as Single Conductors or Assemblies of Single Conductors
ICEA S-93-639/NEMA WC 74	5 - 46 kV Shielded Power Cables for Use in the Transmission and Distribution of Electric Energy
ICEA S-94-649	Concentric Neutral Cables Rated 5 through 46 kV
ICEA S-95-658/NEMA WC 70	Power Cables Rated 2000 Volts or Less for the Distribution of Electrical Energy
ICEA S-96-659/NEMA WC 71	Standard for Nonshielded Cables Rated 2001-5000 Volts for Use in the Distribution of Electric Energy
ICEA S-97-682	Standard for Utility Shielded Power Cables Rated 5 through 46 kV
ICEA S-105-692	Standard for 600 Volt Single Layer Thermoset Insulated Utility Underground Distribution Cables
IEEE 48	Test Procedures and Requirements for Alternating-Current Cable Terminations Used on Shielded Cables Having Laminated Insulation Rated 2.5 kV Through 765 kV or Extruded Insulation Rated 2.5 kV through 500 kV
IEEE 386	Standard for Separable Insulated Connector Systems for Power Distribution Systems Above 600 V
UL 62	Flexible Cords and Cables
UL 467	Grounding and Bonding Equipment
UL 510	Polyvinyl Chloride, Polyethylene, and Rubber Insulating Tape
UL 1072	Medium-Voltage Power Cables
UL 1277	Electrical Power and Control Tray Cables with Optional Optical-Fiber Members

c. Other Standards:

UL Underwriters Laboratories

3. Comply with the applicable reference Specifications as directed in the General Provisions and the Special Provisions.

D. Contractor Submittals

1. Submittals shall be in accordance with Section 01330, the General Provisions, Special Provisions, and as specified herein.

2. Contractor shall submit the following items:
 - a. Catalog cuts and other brochures depicting conductor characteristics.
 - b. Field testing records in accordance with Specification section 16080, Electrical Testing.
 - c. Provide the certifications and other submittal documentation in compliance with Part 3.D - Conductor Arc and Fireproofing Tapes and Part 3.H - Splicing Methods of this Specification.

E. Quality Assurance

1. Comply with the requirements specified herein and the applicable reference Specifications of the General Provisions and Special Provisions.
2. Equipment:
 - a. All test equipment shall be certified within the prior year.
 - b. Provide the certifications and other submittal documentation in compliance with Part 3.H - Splicing Methods of this Specification.
3. Contractor Qualifications: Comply with the requirements for the certifications, licenses, training, skills, experience, and other qualifications specified in Part 3.B - Conductor 600V and Below of this Specification.

F. Conductor Identification System

1. Provide a complete power, control, and signal conductor and cable identification system so that, after installation, conductors and cables shall be easily traced from origin to destination. See Specification section 16075 - Electrical Identification Nameplates and Warning Signs.
2. Conductor and Cable Color Coding:
 - a. Color coding of multiconductor control and instrumentation cable shall be as specified in the individual cable type below.
 - b. For power conductors, provide all single conductors and individual conductors of multiconductor power cables with integral insulation pigmentation of the designated colors, except conductors larger than 6 AWG may be provided with color coding by applying a heat shrink tube of the appropriate color.
 - c. Phase A, B, C implies the direction of positive phase rotation.

d. Use the following colors to identify function/phase:

System	Conductor	Color
All Systems	Equipment Grounding	Green
120/240 V, 1-Phase, 3-Wire	Grounded Neutral	White
	One Hot Leg	Black
	Other Hot Leg	Red
208Y/120 V, 3-Phase, 4-Wire	Grounded Neutral	White
	Phase A	Black
	Phase B	Red
	Phase C	Blue
480Y/277 V, 3-Phase, 4-Wire	Grounded Neutral	White
	Phase A	Brown
	Phase B	Orange
	Phase C	Yellow

PART 2 - PRODUCTS

A. General

1. All conductors and cables shall be listed by UL and shall bear the UL label.
2. Conductor size and cable size 2 AWG and larger shall be manufactured no more than one year prior to installation.
3. Unless otherwise indicated in the Contract Documents, provide stranded conductors.
4. Provide only copper conductors unless otherwise noted on the Contract Documents.
5. All cables below 480V shall be installed in unbroken, unspliced, continuous runs, except as described in Part 3 below, or specifically accepted by the DISTRICT. Any splices, if required, shall be performed by the Contractor at no cost to the DISTRICT.

B. Conductors

1. Power Conductors 600 V and Below:
 - a. Provide Type THHN/THWN or XHHW insulation for lighting, control and instrument cables where the conductors are not underground during any portion of the conduit run. Provide conductors with Type XHHW insulation where conductors are underground during a portion of the conduit run. Manufacturers: Cerrowire, Okonite, Southwire, or equal.
 - b. Conductors for applications of 600V and below shall be rated for 600V, unless otherwise specified.

- c. The name of the manufacturer, UL mark, insulation type, voltage rating, and wire size shall be clearly and permanently imprinted throughout the length of each conductor.
2. Multiconductor Cable:
- a. Provide cable that is UL-listed Type TC, UV-resistant and conforms to the requirements of UL, NEC, or UL-listed Power Limited Circuit that conforms to the requirements of NEC, as applicable. Provide cables permanently and legibly marked with the manufacturer's name, the maximum working voltage for which the cable was tested, the type of cable, and labeled UL.
 - b. Power cable color coding for phase identification shall be in accordance with this Specification. Multiconductor power cables with conductors 6 AWG and larger shall be identified by ICEA Method 3 (single-color compounds with surface printing of numbers and color designations), using Table E-2, and multiconductor cables with conductors 8 AWG and smaller shall be identified by ICEA Method 1 (colored compounds with tracers), using Table E-2.
 - c. All multiconductor cables with conductors 6 AWG and larger shall contain an integral insulated grounding conductor or bare copper stranded grounding conductor incorporated in the outer interstices of the assembled multiconductor cable. All multiconductor power cables 8 AWG and smaller shall contain an integral insulated grounding conductor meeting the sizing requirements of UL 1277.
 - d. Provide cables as specified under the type number in this Specification section (Type 1, Type 2, etc.).
 - (1) Type 1 (600V, Multiconductor Control Cable, a two-conductor cable with green ground can be provided as a power cable to bring power to instruments, Type TC UV-Resistant):
 - (a) General: Multiconductor control circuit (or instrument power) interconnection cable with ground shall be suitable for installation in open air, in cable trays, conduit or other raceways accepted by the DISTRICT. Maximum cable temperature rating shall be 90 degrees C dry locations, 75 degrees C wet locations. Cable shall pass vertical tray flame test.
 - (b) Individual Conductors: 14 AWG, Class B stranded coated or uncoated copper.
 - (c) Insulation and Jackets: Provide conductors having 15-mil PVC insulation with 4-mil nylon jacket, and UL-listed as Type THHN/THWN. Color code the conductor group in accordance with ICEA S-95-658, Method 1, Table E-2. Include one full size green equipment grounding conductor. Bind conductor group with a spiral wrap of barrier tape. Provide cable with overall outer PVC jacket which is flame-retardant, sunlight- and oil-resistant.
 - (d) Provide only 2, 3, 4, 5, 7, 9-, and 12-conductor cables including the green grounding conductor. Manufacturers: Belden, General Cable, Okonite, Southwire, or equal.

MOULTON NIGUEL WATER DISTRICT

- (2) Type 2 (600V, Multiconductor Power Cable, Type TC):
 - (a) General: 3 or 4-conductor, 12 AWG to 4/0 AWG with ground and overall jacket. Suitable for installation in open air, in cable trays, conduit, or other raceways accepted by the DISTRICT. Maximum cable temperature rating shall be 90 degrees C dry locations, 75 degrees C wet locations.
 - (b) Individual Conductors: Class B stranded, coated, or uncoated copper.
 - (c) Insulation and Jacket: Provide conductors insulated with cross-linked polyethylene or ethylene-propylene, UL rated VW-1. Provide sunlight- and oil-resistant PVC outer jacket. Provide phase conductors color-coded red, black, and blue
 - (d) Manufacturers: Belden, General Cable, Okonite, Southwire, or equal.

- (3) Type 3 (600V, 16 AWG, Twisted, Shielded Pair Instrumentation Cable, Type TC) (UL 62 and UL 1277):
 - (a) General: Single-pair instrumentation cable designed for process control, computer, or data log applications. Suitable for installation in cable trays, conduit, or other raceways accepted by the DISTRICT. Maximum cable temperature rating shall be 90 degrees C dry locations, 75 degrees C wet locations.
 - (b) Individual Conductors: Bare soft annealed copper, 7-conductor, Class B stranded; 20 AWG, stranded, and tinned copper drain wire.
 - (c) Insulation and Jacket: Each conductor shall have 15-mil nominal PVC and 4-mil nylon insulation. Pair conductors shall be pigmented as shown in the chart below. Jacket shall be flame-retardant and sunlight- and oil-resistant PVC with 45-mil nominal thickness. Shield shall be 1.35-mil aluminum/mylar overlapped to provide 100 percent coverage.
 - (d) Manufacturers: Okonite, Alpha Wire Corporation, Belden, or equal.

- (4) Type 4 (600V, 16 AWG, Twisted, Shielded Triad Instrumentation Cable, Type TC) (UL 62 and UL 1277):
 - (a) General: Single-triad instrumentation cable designed for process control, computer, or data log applications. Suitable for installation. In cable tray, conduit, or other raceways accepted by the DISTRICT. Maximum cable temperature rating shall be 90 degrees C dry locations, 75 degrees C wet locations.
 - (b) Conductors: Bare soft annealed copper, 7 conductor Class B stranded; 20 AWG, stranded, and tinned copper drain wire.

MOULTON NIGUEL WATER DISTRICT

- (c) Insulation and Jacket: Each conductor shall have 15-mil nominal PVC and 4-mil nylon insulation. Triad conductors shall be pigmented black, red and white. Jacket shall be flame-retardant and sunlight- and oil-resistant PVC with 45-mil nominal thickness. Shield shall be 1.35-mil aluminum/mylar, overlapped to provide 100 percent coverage.
- (d) Manufacturers: Okonite, Alpha Wire Corporation, Belden, or equal.

e Signal Circuit Wiring:

- (1) Conductor inside control panels shall be flexible stranded copper machine tool wire, UL-listed Type MTW/TEW, rated 600V. Wires for instrument signal circuits and alarm input circuits shall be 14 AWG. All other wires, including shielded cables, shall be 16 AWG minimum. The minimum wire size shall be 16 AWG when wire is used to connect terminal blocks to PLC input and/or output modules.

All 50V and less wiring shall be run separately from 50V and above wiring. Control panel layout shall divide the panel into two sides with wiring and devices that operate above 50V on one side and below 50V on the other.

- (2) Control Panel Internal Wire Insulation Colors: Conductors shall be identified by color-coded insulation. Conductors supplying 120V ac power on the load side of a disconnecting switch shall have black insulation for the ungrounded conductor and white insulation for the neutral. Color coding shall be as follows:

<u>120V ac Power</u>		<u>120V ac Control</u>	
Hot	Black	PLC Output	Red
Neutral	White	PLC Input	Orange
Ground	Green		

<u>24V dc Power</u>		<u>24V dc Control</u>	
Positive (+)	Blue, mark (+)	PLC Output	Pink
Negative (-)	Blue w/ white stripe, mark (-)	PLC Input	Purple

<u>0-5V dc Control</u>		<u>4-20 mA Control</u>	
Positive (+)	Brown, mark (+)	Positive (+)	Red, White, or Clear
Negative (-)	Brown, mark (-)	Negative (-)	Black

<u>Pulse Control</u>		<u>OTHER</u>	
Positive (+)	Tan, mark (+)	Any service not listed above	Yellow
Negative (-)	Tan, mark (-)		

- (3) Control Panel Internal Wire Marking: Each signal, control, alarm, and indicating circuit conductor internal to the control panel that is electrically continuous shall be designated by a single unique number which shall be shown on all shop drawings. These numbers shall be shown on all conductors

at every terminal using machine printed white heat-shrink sleeves shrunk loosely shrunk to allow sleeves to be rotated.

3. Conductor Arc and Fireproofing Materials:
 - a. Provide 3M Scotch 69 tape, 3M Scotch 77 tape, Plymouth Plyarc 30 arc and fireproofing tape, Plymouth Plyglass glass cloth electrical tape, or equal.
4. Conductor and Cable Tags:
 - a. Refer to Specification Section 16075 - Electrical Nameplates and Warning Signs, for tagging information.
5. Equipment Grounding Conductors:
 - a. Provide soft-drawn copper conductors, minimum 12 AWG, and as indicated or as required by NEC, for equipment grounding.
 - b. Provide conductors with green insulation of the same type as all other circuit wires.

PART 3 - EXECUTION

A. General

1. Do not exceed cable manufacturer's recommendations for maximum pulling tensions and minimum bending radii. Where pulling compound is used, provide only UL-listed compound compatible with the cable outer jacket and with the raceway involved.
2. Tighten all screws and terminal bolts using torque wrenches and/or torque screw drivers to the values recommended by the manufacturers.
3. Wires and cables in each voltage classification shall be installed in separate raceways and shall be completely isolated at the cable and wire terminations.
4. A means of monitoring cable tension shall be provided at all pulls. (i.e., dynamometer)

B. Conductor 600V And Below

1. Provide conductor sizes indicated on the Drawings.
2. Wire nuts may be provided on solid conductors of 120V and 277V lighting and 120V receptacle circuits only. Place no more than one conductor in any single-barrel pressure connection. Provide crimp connectors with tools by same manufacturer and/or UL-listed for connectors of all stranded conductors.
3. Soldered mechanical joints insulated with tape shall not be acceptable. Do not use split bolt connectors if the wire sizes differ by 3 or more AWG sizes.
4. Vinyl plastic insulating tape for wire and cable splices and terminations shall be flame retardant, 7-mil thick minimum, rated 90 degrees C minimum meeting the requirements of UL 510.

5. Wrap all conductors that are routed through maintenance holes, handholes, and manholes with 2 layers of vinyl plastic insulating tape.
6. Provide terminals and connectors acceptable for the type of material used.
7. Arrange wiring in cabinets, panels, and electrical equipment neatly, cut wire to proper length, remove surplus wire, bundle, and secure in an acceptable manner. Identify all circuits entering electrical equipment and/or control cabinets in accordance with Specification section 16075, Electrical Identification Nameplates and Warning Signs.
8. Terminate control and instrumentation wiring with methods consistent with terminals provided, and in accordance with terminal manufacturer's instructions. Where terminals provided accept such lugs, terminate all control and instrumentation wiring (except solid thermocouple leads) with insulated, locking-fork compression lugs, Thomas & Betts Sta-Kon, 3M Scotchlok, or equal.
9. Attach compression lugs to wires with a crimping tool specifically designed for that purpose which provides a complete, controlled crimp where the tool will not release until the crimp is complete. Use of plier-type crimpers shall not be acceptable.
10. Cap spare conductors and conductors not terminated with UL-listed end caps.
11. Where conductors pass through holes or over edges in sheet metal, remove all burrs, chamfer all edges, and install bushings and protective strips of insulating material to protect the conductors.
12. For conductors to be connected by others, provide at least 6 feet spare conductor in freestanding panels and at least 2 feet spare in other assemblies. Tape/cap and coil spare conductors in panels and boxes. Provide longer spare length where it is obvious that longer conductor length will be needed to reach the termination point.
13. Contractor shall provide cable pulling tension calculations to the DISTRICT for review and acceptance before pulling cables sized 4/0 AWG and larger.
14. The Contractor shall use cable installers who are experienced in the specific work of cable terminating for the specific types of cable and cable accessories specified in this Specification section.

C. Cables

1. Locate splices, when permitted, only in readily accessible cabinets or junction boxes using terminal strips for low-voltage cables.
2. For connections of instrumentation and control cables, loop adequate length for neat bundled type connections.
3. Instrumentation, computer, and control cables run under infinite access floors in control rooms may be installed under the floor without protection. Run individual wires, pairs, or triads in flex conduit under the floor or grouped into bundles at least one inch in diameter.

4. Maintaining the integrity of shielding of instrumentation cables shall be essential to the operation of the control systems. Take special care in cable installation to ensure that grounds do not occur because of damage to the jacket over the shield.
5. Cables entering maintenance holes, handholes, and manholes shall be sealed using an expanding foam product accepted by the DISTRICT for the purpose.
6. Provide tray-rated cables when conductors are routed through maintenance holes, handholes, and manholes.

D. Conductor ARC and Fireproofing Tapes

1. Follow tape manufacturer's installation instructions. Secure the arc and fireproofing tape at frequent intervals with bands of the specified glass cloth electrical tape. Make each band of at least two wraps of tape directly over each other.
2. Wrap together as far as possible, conductors carrying phases A, B, and C of the same feeder.
3. The cables shall be trained as closely as possible to their final positions.
4. The cables shall be cleaned of all oil, grease, and cable pulling compounds using suitable solvents and cleaners non-injurious to cable and then wiped completely dry.
5. Any projecting surfaces such as fittings, ground connectors and bonding connections shall be covered with an insulating compound to present a smooth continuous surface for taping.
6. Fireproofing tapes shall be submitted as shop drawings for acceptance. Tapes shall be 3 inch width half-lapped and extend a minimum of 6 inches into the raceway. Provide glass tape at three-foot intervals to hold tape in place.

E. Field Tests

1. Field test shall be performed on conductors in accordance with Specification section 16080 - Electrical Testing.

F. Underground Wire and Cable Installation

1. Wire and Cable Installation
 - a. Before pulling wire and cable in underground conduit, the conduit shall be mandreled with a painted wooden mandrel 2-1/2 inches long having a diameter of 1/2 inch smaller than the inside diameter of the conduit.
 - b. Conductors shall be installed using a nylon pulling rope. A nylon pulling rope shall be left in each spare underground conduit for future installations.
 - c. The pulling compound for all types of wire and cables, except thermocouple wire, shall be a water-based gel lubricant, American Polywater Corp. "Polywater Lubricant J", Ideal Industries, Inc., or equal. Thermocouple wire shall be pulled in dry.
 - d. Care shall be taken to avoid sharply binding and/or kinking conductors, damaging insulation, and/or stressing cable /wire beyond manufacturer's recommendations during pulling. Maximum calculated cable pulling tensions and sidewall pressures shall not be exceeded during cable pulling.

G. Terminations and Splices

1. Terminations and Splices: Splicing cables in conduits and cable trays shall be prohibited. Where required, lighting and 120V receptacle circuits using solid 12 AWG conductors may be spliced in conduit fittings using twist-on-type connections. A tubular crimp-type splice shall be provided for stranded conductors. Conductors shall be spliced in enclosures or fittings accepted by the DISTRICT for the purpose. The number of splices shall be kept to a minimum.
 - a. Splicing shall join conductors mechanically and electrically to provide a complete circuit prior to installation and/or insulation. Splices in wet and corrosive locations and below grade shall be waterproof, heat-shrink type as manufactured by Elastimold, Tyco-Raychem, or equal.
 - b. Splices at motor junction boxes shall be accomplished by joining of motor lead wire to feeder cable with compression-type lugs. The lugs shall be bolted together with washers, and lock washers. The lugs shall then be insulated using a cold roll-type motor pigtail splice kit as manufactured by 3M, Tyco-Raychem, or equal. Alternatively, Contractor may also use insulated multi-cap connector-type lugs, as manufactured by Polaris, or approved equal.
 - c. All terminations for medium-voltage cable shall be made using termination kits.
 - d. Boxes containing splices shall be sized in accordance with NEC and in no case shall the number of conductors exceed that allowed in NEC. Barriers shall be provided to separate various classes of control and/or power circuits in enclosures where terminations are made.

H. Splicing Methods

1. Field splice methods shall be as described in the following table. Contact the DISTRICT for installations not covered by the table.

CONDUCTORS	ENCLOSURE	SPLICE DETAILS
Below ground level, underground and locations where a splice could be submerged	<ol style="list-style-type: none"> 1. No splices shall be allowed. Select equipment, devices, and sensors that are equipped with pigtails long enough to reach a non-submerged space. 2. If splices are unavoidable, install watertight splices certified by the manufacturer; submit certification, catalog cut sheets, and installation manual. 	
Signal level conductors such as intrinsic-safe elements, devices with digital input loads only, i.e.: Float Switches; Position Switches.	Terminal Junction Box Enclosure suitable for the environment, independently supported, and meeting the requirements of this Specification.	Terminal Junction Box Individual terminal blocks with 25 percent spare terminal blocks providing separate connection point for each conductor. Terminal blocks shall be suitable for connection within low signal level circuits.
Conductors rated 600V ac, i.e.: all types	Terminal Junction Box Enclosure suitable for the environment, independently supported, and meeting the	Terminal Junction Box Individual terminal blocks providing separate connection point for each conductor with one spare terminal block.

CONDUCTORS	ENCLOSURE	SPLICE DETAILS
	requirements of this Specification.	

END OF SECTION

SECTION 16130

RACEWAY SYSTEMS AND PULL BOXES

PART 1 - GENERAL

A. The Requirement

1. The Contractor shall furnish all tools, equipment, materials, supplies, and labor required to complete the Work as indicated on the Drawings and specified herein.
2. General
 - a. The Contractor shall furnish and install raceway systems as described herein and as indicated on the Contract Documents. Raceway systems shall include conduit, cable tray, lay-in wiring duct, fittings, fasteners, boxes, and other associated raceway devices. All conduits shall be selected in accordance with this Specification.
 - b. Conduit runs shall be field verified for scale dimensions shown on the Contract Documents, since actual locations, distances, and levels will be governed by field conditions. Conduit runs indicated on the Contract Documents are schematic only, and shall be modified as required to suit the field conditions, subject to review and written acceptance by the DISTRICT.
 - c. The Contractor shall install new conductors and cables in existing conduit after demolishing the existing conductors. Comply with conduit preparation requirements in PART 3 - Execution.

B. Related Work Specified Elsewhere

1. The requirements of the following sections and divisions apply to the Work of this section. Other sections and divisions of the Specifications, not referenced below, shall also apply to the extent required for proper performance of this Work.
 - a. Section 09900 - Painting and Coating
 - b. Section 16010 - Electrical General Provisions
 - c. Section 16075 - Electrical Identification Nameplates and Warning Signs
 - d. Section 16120 - Conductors and Cables
 - e. Division 16, Electrical, other applicable sections

C. Reference Specifications, Codes, and Standards

1. All Work specified herein shall conform to or exceed the applicable requirements of the referenced portions of the following publications to the extent that the provisions thereof are not in conflict with other provisions of these Specifications.

2. Comply with the applicable editions of the following codes, regulations, and standards:
 - a. Codes and Regulations:

29 CFR 1910	Code of Federal Regulations, Title 29, Part 1910, U.S. Occupational Safety and Health Standards (OSHA)
CCR	California Code of Regulations, Title 8, Div. 1, Chap. 4, Subchap. 5, Electrical Safety Orders
CCR	California Code of Regulations, Title 24, Part 3, California Electrical Code
NFPA 70	National Electrical Code (NEC)
IEEE C2	National Electrical Safety Code (NESC)
 - b. Industry Standards:

NEMA C80.1	Electrical Rigid Steel Conduit – Zinc-Coated (ERSC)
NEMA FB 1	Fittings, Cast Metal Boxes, and Conduit Bodies for Conduit, Electrical Metallic Tubing, and Cable
UL 467	Grounding and Bonding Equipment
UL 514B	Conduit, Tubing, and Cable Fittings
Intertek ETL SEMKO	Directory of ETL Verified and ETL Listed Cabling Products
 - c. Other Standards:

AASHTO	American Association of State Highway and Transportation Officials
ETL	Intertek ETL SEMKO (formerly Electrical Testing Laboratory)
NEMA	National Electrical Manufacturers Association
UL	Underwriters Laboratories
3. Comply with the applicable reference Specifications as directed in the General Provisions and the Special Provisions.

D. Contractor Submittals

1. Submittals shall be in accordance with Section 01330, the General Provisions, Special Provisions, and as specified herein.
2. Submittals shall include the following:
 - a. Catalog cuts, bulletins, or brochures shall be submitted for mass-produced non-custom material.
 - b. Proposed locations, proposed quantities and proposed sizes of pull boxes shall be submitted to the DISTRICT as indicated in Part 3.A – General of this Specification.

E. Quality Assurance

1. General: Comply with the requirements specified herein and the applicable reference Specifications of the General Provisions and Special Provisions.
2. Contractor Qualifications: Each person who will be installing PVC-coated conduit shall have attended a certification training course by the manufacturer within one year of installing PVC-coated conduit, fittings, or boxes. Training shall include methods of installation without damaging coating and demonstration of method of repair of coating.

F. Warranty

1. Provide manufacturer's standard warranty unless specified otherwise in the General Provisions and Special Provisions.

PART 2 - PRODUCTS

A. General

1. All material shall be listed by UL or an OSHA-recognized testing laboratory.
2. Conduit type selection is specified in Part 3.

B. PVC Schedule 40 Conduit

1. Rigid PVC Schedule 40 conduit shall be UL listed for concrete-encased, underground direct burial, concealed and direct sunlight-exposed use, and UL-listed and marked for use with conductors having 90 degrees C insulation. Conduits, couplings, bushings, elbows, nipples, and other fittings shall meet the requirements of NEMA, UL, and NEC requirements. Manufacturers shall be Carlon, Allied Tube and Conduit, JM Eagle, or equal.

C. PVC Schedule 80 Conduit

1. Rigid PVC Schedule 80 conduit shall be extra heavy wall, UL-listed for concrete-encased, underground direct burial, concealed, and direct sunlight-exposed use, and UL- listed and marked for use with conductors having 90 degrees C insulation. Conduit, couplings, bushings, elbows, nipples, and other fittings shall meet the requirements of NEMA, UL, and NEC. Manufacturers shall be Carlon, Allied Tube and Conduit, JM Eagle, or equal.

D. PVC-Coated Rigid Steel Conduit

1. PVC-coated galvanized rigid steel conduit and fittings shall meet the requirements of NEMA C80.1, NEMA RN-1, ASTM D870, ASTM D1151, UL 514B, and NEC. The exterior PVC coating of the conduits shall have nominal thickness of 40 mils bonded to the metal. The PVC coating shall be UV-resistant. The interior surfaces shall be lined with corrosion resistant coating to a nominal thickness of 2 mils. The exterior of couplings shall also have molded ribs to protect the coating from tool damage during installation. A loose coupling shall be furnished with each length of conduit. The PVC sleeve equal to the outside diameter of the conduit shall extend beyond both ends of the coupling approximately one pipe diameter or two inches, whichever is smaller. All conduit body hubs shall have sleeves with same features as the coupling sleeves specified above.

2. Conduits shall be tested and certified to ETL PVC-001 or to an equivalent verification program conducted by an OSHA-recognized testing laboratory. Initial compliance requires conduit samples to pass minimum 200 hours without adhesion failure immersed in boiling water (ASTM D870) and conduits to pass 90 days without adhesion failure in a heat/humidity chamber of 150 degrees F and 95 percent relative humidity (ASTM D1151). Adhesion tests shall be in accordance with NEMA RN-1. Each conduit shall bear an ETL PVC-001 label or equivalent label. The label signifies that the testing laboratory has randomly selected and retested conduit samples to the ASTM D870 standard on an on-going quarterly basis to verify compliance. Manufactures shall be Kor-Kap, Perma-Cote, Plasti-Bond, or equal.

E. Flexible Non-Metallic Conduit, Liquid-Tight

1. Flexible metal conduit shall be UL-listed liquid-tight consisting of PVC flexible conduit. Conduit straps shall be two-hole PVC straps nut and bolt connected to the structure Rigid Steel Conduit Fittings:
 - a. Insulated throat bushings shall be metal with integral plastic bushings rated for 105 degrees C and shall be Thomas & Betts Nylon Insulated Metallic Bushings, O.Z. Gedney Type B, or equal.
 - b. Grounding bushings shall have insulated throats, lay-in grounding wire clamp and minimum two set screws to insure electrical connection from bushing to conduit.
 - c. Hubs with grounding bushings shall be used to terminate rigid steel conduits at enclosures. Hubs shall be Crouse-Hinds Myers Scru-Tite, Appleton HUBG, or equal. Use PVC-coated hubs with grounding bushings for PVC-coated galvanized rigid conduits.
 - d. Conduit bodies in wet and corrosive areas shall be PVC-coated in accordance with PVC-coated rigid steel conduit requirements.
 - e. Provide insulated throat connectors for liquid-tight flexible metal conduit of metal with an integral plastic bushing rated for 105 degrees C, and of the long design type extending outside of the box or other device at least 2 inches. Provide Thomas & Betts Super-Tite, nylon insulated connectors, Crouse Hinds Series LT, or equal.
 - f. Provide non-metallic PVC flexible conduit connectors from the same manufacturer as the conduit.
 - g. Cord and cable fittings shall be Crouse-Hinds CGB, Appleton CG Series, or equal.

F. Raceway Tags and Markers

1. Refer to Specification section 16075 - Electrical Identification Nameplates and Warning Signs for conduit designation and identification requirements.

G. Warning Tape

1. Warning tape for use in trenches containing electric circuits shall be heavy-gauge, red plastic of 36 -inch minimum width made of material resistant to corrosive soil. The tape shall be printed with black legend at regular intervals indicating that an electric circuit is located below the tape. Manufacturers shall be ITT Blackburn Type YT or RT, Presco, Reef Industries Terra Tape, or equal.

H. Pull Boxes

1. Refer to Specification section 16075 - Electrical Identification Nameplates and Warning Signs, for pull box identification requirements.
2. Above Grade Pull Boxes
 - a. Pull boxes located in non-classified wet and corrosive areas shall be NEMA 4X Type 316 stainless steel with hinged gasketed covers. Weatherproof conduit hubs shall be furnished for all conduit connections to pull boxes. Covers hardware shall be Type 316 stainless steel. Manufacturers shall be Hoffman Engineering Co., Hammond Manufacturing, Cooper B-Line, or equal.
 - b. Pull boxes located in non-classified general purpose dry locations shall be NEMA 1 with gasket. Boxes shall be hot-dip galvanized or painted steel. Manufacturers shall be Hoffman Engineering Co., Hammond Manufacturing, Cooper B-Line, or equal.
 - c. Pull boxes located in classified areas shall be NEMA 7 cast aluminum or iron with hinged cover.

I. Enclosures

1. All enclosures located in wet and corrosive non-classified areas or wet, corrosive, and classified areas (Class 1, Division 2) containing non-sparking or intrinsically safe devices shall be NEMA 4X Type 316 stainless steel. Except as noted otherwise, the enclosures shall have hinged covers, Type 316 stainless steel backplates, Type 316 stainless steel latches and hardware as manufactured by Hoffman Manufacturing Co., Hammond Manufacturing, Cooper B-Line, or equal. This includes enclosures to house electrical controls, instruments, terminal blocks, and other such equipment. Polycarbonate transparent covers shall be provided as indicated on the Contract Documents.
2. Enclosures located in non-classified general purpose dry locations shall be NEMA 1 with gasket NEMA 12. Boxes shall be hot-dip galvanized or painted steel with painted backplates. Manufacturers shall be Hoffman Engineering Co., Hammond Manufacturing, Cooper B-Line, or equal.
3. Enclosures located in wet, corrosive, and classified areas containing devices that are not explosion-proof shall be NEMA 7, Type 316 stainless steel. Manufacturers shall be Crouse-Hinds, Appleton, Killark, or equal.

PART 3 - EXECUTION

A. General

1. Provide raceway systems meeting or exceeding the requirements of the NEC.
2. Provide hinged-cover or screw-cover, NEMA 4X, Type 316 stainless steel, wireway and auxiliary gutter where indicated or where required for a complete and NEC-compliant installation.
3. Seal Conduit Ends: Seal all control and instrument conduit openings entering control panels, control devices, and instruments with an expandable or a re-enterable sealant acceptable to the DISTRICT to prevent condensation in the conduits draining into these enclosures. Conduits connecting electrical equipment, lighting, and receptacle with both ends located in the same general purpose dry location do not require sealing.
4. Above-Grade Conduit:
 - a. Conduit shall be properly fastened and supported at intervals of 10 feet maximum. Additional supports shall be installed at bends and fixtures to make the system rigid. Conduit shall be fastened to steel structural shapes by means of clamp or device made for this purpose and acceptable to the DISTRICT. On masonry structures, conduit shall be fastened with one-hole pipe clamps and back straps with flush anchors and machine screws or concrete anchors. The use of channel supports shall be required for banks of conduit. Where conduit rows are installed vertically, spacers shall be provided to prevent conduit straps or clamps from slipping. Banks of conduit shall have 30 percent spare space for future conduit row(s). Installation shall be made on the channel supports.
 - b. Conduits shall not be attached to handrails, ladders or pipes for support.
 - c. Do not use setscrew type couplings, bushings, bends, nipples, and other fittings on galvanized rigid steel conduit system.
 - d. Liquid-tight flexible metal conduit of a maximum length of five feet with fittings shall be provided where flexible connections are required. Terminate flexible metal conduit with nylon bushings or bushings with steel or malleable iron body and insulated throat and sealing O-ring. If flexible conduit is required for installations in Class I, Division 1 areas, explosion-proof flexible conduit and connection fittings shall be provided.
 - e. The conduit system, including junction boxes and splice boxes, shall be furnished with drain fittings. The conduit system shall be designed to slope toward the drain fitting to prevent the accumulation of condensate in the conduit. All conduit entrances shall be from the bottom or side, where practical. Entrances from the top should be avoided. Vertical conduit runs in wet and corrosive or wet, corrosive, and hazardous areas shall have drain fittings at the bottom of the runs. The seals above and below control stations shall be of the drain type where at the bottom of vertical runs over 30 feet. Where explosion-proof fittings are not required, the drain in conduit runs shall be a T-fitting with the drain located at the low point of the run.
 - f. Explosion-proof boxes shall have drains and breathers.

- g. All devices that depend on a single seal diaphragm or tube to prevent process liquids or gases from entering the conduit system shall be provided with a drain-type seal fitting or a drain on the bottom of the device with a seal fitting. This includes canned pumps and devices used for flow, pressure and analysis measurement.
 - h. All metal surfaces, except for struts, coming into contact with concrete shall have two-part coal-tar epoxy coating field-applied per coating manufacturer's instructions. Floor-mounted stanchions shall be level, with space beneath for field grouting. Boxes and cubicles shall be installed with leveling tools so that they will be level, plumb, and properly aligned with the proper method of support. This method of support shall be by concrete anchors, or shall be by mounting on angle, plate, or other structural supports anchored to floor, wall, ceiling or equipment foundation. This includes all enclosed or partially enclosed instruments, pushbutton or selector switch control stations, pull boxes, junction boxes, outlet boxes, starters, controllers, distribution panels, lighting panels, instrument panels, and control centers.
 - i. Conduit runs shall not interfere with the proper and safe operation of equipment and shall not block or interfere with ingress or egress, including equipment removal hatches.
 - j. Conduit runs on dry-side of water-bearing walls shall be supported a minimum of 1/4 inch away from the wall or on channel supports. No conduit shall be run in water-bearing walls, unless specifically designated by the DISTRICT in writing.
 - k. Provide cord and cable fittings forming a watertight non-slip connection to pass cords and cables into conduit or conduit boxes. Size the fitting according to the outside diameter of cord or cable.
5. Raceway Tags and Markers: Exposed conduits shall be identified with tags and markers per Section 16075 unless noted otherwise.
6. Pull Boxes: Pull Boxes shall be installed in addition to those shown on the Drawings, as required to meet cable manufacturer's pulling tension and side wall pressure requirements, and as directed by the DISTRICT in writing. They shall be placed so that access is not restricted by obstructions such as pipes, valves, ladders, etc. The final locations of the pull boxes shall not intervene with walking spaces. Proposed locations, proposed quantities and proposed sizes shall be submitted to the DISTRICT for review and written acceptance prior to fabrication and installation.
- a. The Contractor shall size all pull boxes in accordance with National Electrical Code requirements and shall also size pull boxes to provide room for the future conduits and cables indicated on the Contract Documents.

B. Protection During Construction

- 1. In addition to the provisions of the General Provisions and Specification section 16010 - Electrical General Provisions, prior to installation, store all products specified in this Specification section in a dry location. Protect products from the effects of moisture, corrosion, and physical damage during construction. Keep openings in conduit, conduit body, and box capped with manufactured seals during construction.

C. Minimum Raceway Size

1. Use no circular raceway less than 3/4 inch except final conduit leg to devices with an integral 1/2-inch hub may be 1/2 inch.

D. Required Raceway Type for Location and Installation Method

1. Install raceway types in accordance with Tables 1 and 2 below:

Table 1: Above Ground Conduits

Application	Material (Wet and Corrosive Locations)	Material (Dry Locations)
Power and control	galvanized rigid steel, PVC coated	galvanized rigid steel, PVC coated
Switchboard Interior		non-metallic PVC flex
Signal, instrumentation and communication	galvanized rigid steel, PVC Coated	galvanized rigid steel, PVC Coated

Table 2: Underground Conduits

Application	Material
Power and Control	PVC for 480V and below cables
Signal, instrumentation and communication	PVC schedule 40 or 80

2. Final Connection to Certain Equipment
 - a. Make final connection to motors, wall-mounted or ceiling-mounted fans and unit heaters, dry type transformers, valves, local instrumentation, and other equipment where flexible connection is required to minimize vibration or where required to facilitate removal or adjustment of equipment, with liquid-tight, PVC-jacketed, flexible steel conduit.
 - b. The flexible conduit shall be long enough to allow the item to which it is connected to be withdrawn or moved off its base.
3. Special Locations
 - a. PVC coated rigid steel conduit shall follow Table 1 application above:
 1. Where conduit changes from underground and/or concrete embedded to exposed conduit.
 2. Under equipment mounting pads.
 3. In exterior light pole foundations.

E. General Installation Requirements for Raceways

1. Circuit Routing

- a. Power, lighting, control, and instrumentation wiring shall be run in separate raceway systems and shall not be intended to occupy the same enclosure. One motor branch circuit and its associated motor control circuit, such as a motor branch circuit and its associated push button control circuit, may be run in the same raceway or enclosure, as allowed by the NEC.
- b. Conductors for more than one lighting branch circuit may occupy the same raceway or enclosure, providing that the circuits operate at the same voltage. Where two different lighting system voltages are used (e.g., 120V and 277V), separate raceway systems shall be provided for each operating voltage.
- c. Enclosures with mixed voltages used in control wiring systems, such as field relay panels and terminal boxes, shall have separate terminal boards for each voltage level (e.g., 480V, 120V, 12V, etc.) and each voltage level shall be identified by suitable nameplates. The incoming power source shall also be suitably identified.

2. Conduit Installation

- a. General: All conduit systems shall be designed with adequate pull points for all types of cable systems. Wire and cable pulling tensions and sidewall pressures shall not exceed the maximum values specified by the cable manufacturer. Cable pulling calculations shall be submitted as specified in Specification section 16120 - Conductors and Cables, or whenever requested by the DISTRICT.
- b. Conduit shall be cut square and all ends suitably reamed and threaded for connection to couplings or fittings. All threads shall be cleaned with a die. No running threads or Ericson couplings shall be permitted. Nylon insulated bushings shall be provided on the ends of all conduits terminating in junction boxes, pull boxes, panelboards, control panels, etc. as well as on all conduits entering and leaving underground electrical boxes.
- c. Connections to couplings and fittings shall be made using Ideal Industries "Noalox" joint compound or equal.
- d. Provide pullboxes or wireways where the quantity and size of conduit set to enter an enclosure is greater than the available surface area. Separate power from control and from signal conduit should pullboxes or wireways be needed.
- e. Conduit bends shall have a radius greater than the minimum bending radius of the cables to be installed in the conduit. This may require oversize conduit fittings in locations where "C" fittings, elbows and tees are used to make bends. Conduit fittings for cable size 4/0 AWG and larger shall be of the "LBD" type. Conduit fittings for telephone cables of 2 inches in diameter and larger shall be of the "LBD" type. Minimum bending radius requirement of cable or wire stated in NEC shall not be exceeded.
- f. All fittings and condulets in the conduit system shall be the taper-thread type. All condulets shall have PVC-coated "Form 7" covers in wet and corrosive and wet, corrosive, and hazardous locations, except as noted above.

- g. The entire conduit system shall be fished or snaked clean after it is installed. The system shall be free of burrs and other foreign obstructions and these shall be removed by some mechanical means accepted by the DISTRICT.
3. Location, Routing, and Grouping:
- a. Conceal or expose raceways as indicated. Group raceways in same area together. Locate raceways at least 6 inches away from parallel runs of heated piping with surface temperatures above 140 degrees F.
 - b. Run exposed raceways parallel or perpendicular to walls, structural members, or intersections of vertical planes to provide a neat appearance. Follow surface contours as much as possible.
 - c. Avoid obstruction of passageways. Run concealed raceways with a minimum of bends in the shortest practical distance considering the building construction and other systems.
 - d. In underground, or wet and corrosive locations, make conduit connections watertight. Install and equip boxes and fittings so as to prevent water from entering the raceway.
 - e. Paint all threads of galvanized conduits with UL-approved zinc-rich paint or liquid galvanizing compound before assembling. Touch up after assembly to cover nicks or scars.
 - f. Do not notch or penetrate structural members for passage of raceways except with prior written acceptance by the DISTRICT.
 - g. Do not run raceways in equipment base foundations.
 - h. Locate above ground raceways concealed in poured concrete so that the minimum concrete covering is not less than 1-1/2 inch.
 - i. Separate conduits in slabs and conduit crossings in slabs shall be spaced in accordance with the requirements shown on the Drawings.
 - j. Raceways installed under slab floors shall lie completely under the slab with no part of the horizontal run of the raceway embedded within the slab.
 - k. Install concealed, embedded, and buried raceways so that they emerge at right angles to the surface. Provide support during pouring of concrete to ensure that raceways remain in position.
 - l. Allow minimum headroom of 6.5 feet for conduit passing over walkways.
4. Bends:
- a. Make changes in direction of runs with symmetrical bends. Make bends and offsets of the longest practical radius. Do not heat metal raceways to facilitate bending.
 - b. Make bends in parallel or banked runs of raceways from the same center or centerline so that bends are parallel and of neat appearance. Make field bends in parallel runs.
 - c. For PVC conduits, provide factory-made bend for all bends 30 degrees or larger. Provide PVC-coated rigid steel bends on all 90-degree bends in PVC conduits. Use acceptable heating methods for forming smaller PVC bends.
 - d. Make no bends in flexible conduit that exceed 90 degrees or allowable bending radius of the cable to be installed or that significantly restricts the conduits flexibility.

- e. All bends for communication cable conduits shall meet minimum bending radius requirements for the cable deployed in the conduit.
5. Bushing and Insulating Sleeves:
- a. Where metallic conduit enters metal equipment enclosures through conduit openings, install a bonding bushing on the end of each conduit. Install a bonding jumper from the bushing to any equipment ground bus or ground pad.
 - b. If neither exists, connect the jumper to a threaded bolt connection to the metallic enclosure.
 - c. Provide manufacturer's standard insulating sleeves in all metallic conduits or insulated bushings terminating at an enclosure.
6. PVC Conduit: Solvent weld PVC conduit joints with solvent recommended by the conduit manufacturer. Follow manufacturer's solvent welding instructions and provide watertight joints. Provide acceptable PVC terminal adapters when joining PVC conduit to metallic fittings. Provide acceptable PVC female adapters when joining PVC conduit to rigid metal conduit.
7. PVC-Coated Conduit: Install in strict accordance with the manufacturer's instructions including use of manufacturer's recommended tools. Touch up any damage to the coating with conduit manufacturer's acceptable patching compound and build up surface thickness to match the factory coating thickness. PVC sealing sleeves shall cover all threads.
8. Penetrations:
- a. Seal the interior of all raceways entering structures at the first box or outlet with duct-seal or suitable plastic expandable compound to prevent the entrance into the structure of gases, liquids, or rodents.
 - b. Dry pack with non-shrink grout around raceways that penetrate concrete walls, floors, or ceilings aboveground, or use one of the methods specified for underground penetrations.
 - c. Where an underground conduit enters a structure through a concrete roof or a membrane waterproofed wall or floor, provide an acceptable, malleable iron, watertight, entrance sealing device. When there is no raceway concrete encasement specified or indicated, provide such a device having a gland-type sealing assembly at each end, with pressure bushings, which may be tightened at any time. When there is raceway concrete encasement specified or indicated, provide such a device with a gland type sealing assembly on the accessible side. Securely anchor all such devices into the masonry construction with one or more integral flanges. Secure membrane waterproofing to such devices in a permanently watertight manner.
 - d. Where raceways penetrate fire-rated walls, floors, or ceilings, firestop openings around electrical penetrations to maintain the fire-resistance rating.
 - e. Raceways passing through roofs shall be flashed.
 - f. Provide conduit seals where required by Article 500 of the NEC.

F. Installation Requirements for Underground Raceway

1. Underground Conduit System Work: Minimum conduit size shall be 1-inch. The minimum size conduit for medium-voltage circuits shall be 3 inches.
 - a. The distance between grade and top of duct banks shall be a minimum of 24 inches. Conduit spacing shall be in accordance with the dimensions shown on the Drawings. All duct banks shall be reinforced in accordance with DISTRICT Standards. Vibrate concrete at all duct bank windows.
 - b. Conduit runs shall be encased in red-colored concrete to a minimum cover of 3 inches, and a maximum cover of 5 inches, top, bottom and sides. To ensure proper coverage, forming with plywood shall be required on bends and trench cave-ins. Concrete shall be as specified in Division 03 of these Specifications. All underground conduits run terminations shall have concrete encasement extended 6 inches above grade. Conduits entering or exiting concrete shall be PVC-coated galvanized rigid steel conduits. Spare conduits that enter a paved or concrete area shall have the top of the coupling flush with the grade. All underground conduit systems shall be installed sloped to drain into manholes. The amount of slope shall be suitable for proper drainage of conduits and the length of the individual runs.
 - c. Bends for conduits shall have a minimum bending radius of 10 times the diameter of the conduit.
 - d. For PVC conduits, provide factory-made bend for all bends 30 degrees or larger. Provide PVC-coated galvanized rigid steel bends on all 90-degree bends in PVC conduits.
 - e. Underground conduits that are identified by a conduit schedule shall have the identification number laser etched or engraved to a round 2-inch minimum Type 316 stainless steel tag, and the tag attached to the conduit as it enters and exits electrical equipment.
 - f. Necessary pull boxes and fittings shall be installed to facilitate pulling wire and cable. The location of pull boxes and fittings shall be in accordance with good installation practice and as shown on the Drawings. A sufficient number of pull boxes shall be provided in each conduit duct bank to enable the pulling of the wires or cables into the conduit without excessively stressing the wires or cables.
2. General:
 - a. Coordinate installation of underground raceways with other outside and building construction Work. Maintain existing outside utilities in operation unless otherwise authorized by the DISTRICT.
 - b. Remove entirely and properly reinstall all raceway installations not in compliance with these requirements.
 - c. Do not use union type fittings underground.
 - d. When underground direct burial conduits are used, such as required by SDG&E or SCE, provide a minimum cover of 24 inches unless otherwise indicated.

- e. Where a concrete-encased duct bank is installed over an extensive area of disturbed earth such as that within the periphery of a building, provide a separate concrete base under the duct bank to ensure stability of raceways during installation. Allow this base to set before the duct bank is installed. No direct burial shall be allowed.

Do not backfill underground direct burial conduits and concrete-encased raceways until they have been inspected by the DISTRICT.

- f. Warning Tapes: Bury warning tapes approximately 8 inches below grade and above all underground conduit runs or duct banks. Align tape parallel to and within 12 inches of the centerline of runs.

3. Separation and Support:

- a. Separate parallel runs of two or more raceways in a single trench with preformed, nonmetallic spacers designed for the purpose. Install spacers at intervals not greater than that specified in the NEC for support of the type raceways used, and in no case greater than 10 feet.
- b. Support raceways installed in fill areas to prevent accidental bending until concrete pouring or backfilling is complete. Tie raceways to supports and supports to the ground, so that raceways will not be displaced when concrete encasement or earth backfill is placed. Conduit ties shall be nonmetallic

4. Arrangement and Routing:

- a. Arrange multiple conduit runs substantially in accordance with details shown on the Drawings. Locate underground conduits where indicated on the Drawings and graded to the elevations shown.
- b. Make minor changes in location or cross-section as necessary but maintain conduit spacing to avoid obstructions or conflicts. Where raceway runs cannot be installed substantially as shown because of conditions not discoverable prior to digging of trenches, refer the condition to the DISTRICT for written instructions before further Work is done.
- c. Where other utility piping systems are encountered, or being installed along a raceway route, maintain a 12-inch minimum vertical separation between raceways and other systems at crossings. Maintain a 12-inch minimum separation between raceways and other systems in parallel runs. Do not place raceways over valves or couplings in other piping systems. Refer conflicts with these requirements to the DISTRICT for written instructions before further Work is done.
- d. In multiple conduit runs, stagger raceway coupling locations so that couplings in adjacent raceways are not in the same transverse line.
- e. All conduits shall enter maintenance holes and structures at right angles.
- f. Provide expandable grommets for concrete-encased raceway passing through wall to the earth.

5. Direct Earth Burial Conduit Zone Backfill Installation:

- a. Direct burial conduit shall be installed only where specifically indicated in the Contract Documents.

- b. Backfill material for the conduit zone of direct burial conduit trenches may be selected from the excavated material if it is free from roots, foreign material, and oversized particles. Provide material with 3/4-inch maximum particle size and suitable gradation for compaction acceptable to the DISTRICT. Remove material if necessary to meet these requirements.
 - c. Imported 3/4-inch minus gravel or sand may be used in lieu of material from the excavation.
 - d. After conduits have been properly installed, backfill the trench with specified material placed around the conduits and carefully tamped around and over them with hand tampers. Final, tamped conduit cover shall be 4-inch minimum.
6. Concrete Encasement:
- a. Encase conduits in a red concrete envelope sized as indicated and located at the elevation shown. Provide concrete as specified in Specification section 03300, Concrete.
 - b. Maintain a grade of at least 4 inches per 100 feet, either from one maintenance hole or pull box to the next, or from a high point between them, depending on the surface contour.
 - c. Hold conduits for concrete-encased raceways securely in place by acceptable window-type spacer supports. Where, in the opinion of the DISTRICT, ground conditions are such as to require concrete forms, install forms constructed of materials and in a manner acceptable to the DISTRICT. No variations greater than 1/2 inch in 50 feet shall be permitted from a straight line.
 - d. Envelopes may be poured directly against the sides of trenches if the cut is clean, even, and free of loose material. Remove loose material from trenches before and during pouring of concrete to ensure sound envelopes. Carefully vibrate concrete during pouring to eliminate all voids under and between raceways and honeycombing of the exterior surface.
 - e. Generally, pour an entire concrete envelope in one continuous pour. Where more than one pour is necessary, terminate each pour in a sloped plane.
7. Backfill Installation above Conduit Zone of Direct Burial Conduit or above Concrete Envelope of Concrete Encased Conduit:
- a. Backfill material above the conduit zone of direct burial conduit or above concrete envelope of concrete-encased conduit may be selected from the excavated material, if it contains no particles larger than 3 inches in diameter and is free from roots or debris. Imported material meeting these same requirements may be used in lieu of material from the excavation. Compact backfill in maximum 12-inch layers to at least 95 percent of the maximum density at optimum moisture content as determined by ASTM D1557.
8. As-Built Drawings: Contractor shall be responsible for documenting the as-built condition and location of all installed underground conduit / duct banks.

G. Preparation for Pulling in Conductors

1. Demolish existing conductors and cables where indicated on the Contract Drawings. Should the existing conductors be difficult to remove, blow out the conduit using high pressure air, and then inject wire lube. Replace any visible conduit that is damaged. Re-route and/or re-terminate conduit to the desired location if needed.
2. For concrete-encased raceways (after the concrete envelope has set) and existing raceways that are to be reused, pull a mandrel of a diameter approximately 1/2 inch less than the raceway inside diameter through each raceway. Then pull a bristle brush through each raceway to remove debris.
3. Replace new raceway that has been crushed or deformed. Take care to prevent entry of foreign material in raceways, boxes, fittings, and equipment during the course of construction. Make inside of raceways entirely free of obstructions or replace them. Ream all raceways, remove burrs, and clean raceway interior before introducing conductors or pull wires.
4. Immediately after installation, plug or cap all raceway ends with watertight and dust-tight seals until the time for pulling in conductors.

END OF SECTION

SECTION 16160

PANELBOARDS

PART 1 - GENERAL

A. Description

This section describes materials, testing, and installation of panelboards.

B. Related Work Specified Elsewhere

1. Electrical General Provisions: 16010
2. Electrical Identification Nameplates and Warning Signs: 16075
3. Low-Voltage Motor Control: 16480

C. Submittals

1. Shop drawings shall be submitted in accordance with the General Provisions, Section 16010, and as specified herein.
2. Provide ratings and characteristics including voltage ratings, bussing arrangement, continuous current ratings, fault current withstand ratings, neutral bus rating, enclosure type, ratings and arrangement of overcurrent protective devices, and mounting provisions.

PART 2 - MATERIALS

A. General

Dead front, safety type, with 120/240v, 120/208v, 277/480v, or 480v ratings as scheduled. Panelboards shall be circuit breaker type and suitable for the short circuit and duty ratings specified or at a minimum have the same short circuit rating as the upstream feeder circuit breaker, whichever rating is higher. Panelboards shall be three-phase 4-wire unless otherwise noted. Refer to Contract Drawings and/or as specified herein for panelboard NEMA ratings. Panelboards shall be as manufactured by Square D or Cutler Hammer, no equal.

B. Breakers

1. All breakers shall be molded-case type. Provide quick-make and quick-break toggle mechanism, inverse-time trip characteristics, and trip-free operation on overload or short circuit. Automatic tripping shall be indicated by a handle position between the manual OFF and ON position. Provide trip ratings as indicated in the panelboard schedules. Provide lock-on or lock-off devices where indicated on the drawings.
2. Single-pole breakers shall be full module size; two poles shall not be installed in a single module. Multiple circuit breakers shall be of the common-trip type having a single operating handle.

MOULTON NIGUEL WATER DISTRICT

3. Furnish ground-fault circuit interrupter (GFCI), 5-ma trip, 10,000-ampere interrupting capacity circuit breakers where indicated and for all 120 volt AC receptacles circuits.

C. Circuit Breaker Connections

Circuit breaker current-carrying connections to the bus shall be of the bolted type, factory assembled.

D. Bus Bars

Bus bars shall be tinned copper. Provide a copper ground bus bar installed on the panelboard frame, bonded to the box, and containing at least 10 terminal screws.

E. Space Only

Where "space only" is noted on the drawings, provide connectors, mounting brackets and any other hardware necessary for the future insertion of an overcurrent device of the size indicated.

F. Nameplates

Provide nameplates as specified in Section 16075, Electrical Identification Nameplates and Warning Signs. Designate the identifying nomenclature, voltage, and phase of the panel as shown on the drawings. For example, "PANEL A, 120/208-volt, three-phase, 4-wire, 100-ampere bus".

G. Enclosures

Enclosure requirements shall be NEMA 1 for indoor use and NEMA 3R for outdoor use unless otherwise specified in the Contract Drawings.

PART 3 – EXECUTION

A. General

Install panelboards in accordance with manufacturer's recommendations.

B. Circuit Schedule

Provide typed circuit schedule listing permanently attached to the inside surface of the panelboard access door. Handwritten directories are unacceptable.

END OF SECTION

SECTION 16290

POWER MONITORS

PART 1 - GENERAL

A. The Requirement

- 1. The MCC manufacturer shall install power monitors, current transformers, and potential transformers, all in accordance with the intent and requirements of the Contract Documents.

B. Related Work Specified Elsewhere

The requirements of the following sections and divisions apply to the work of this section. Other sections and divisions of the Specifications, not referenced below, shall also apply to the extent required for proper performance of this work.

- 1. Electrical Testing 16080
- 2. Low-Voltage Motor Control 16480
- 3. Electrical, other applicable sections Division 16

C. Reference Specifications, Codes and Standards

- 1. All work specified herein shall conform to or exceed the applicable requirements of the referenced portions of the following publications to the extent that the provisions thereof are not in conflict with other provisions of these Specifications.

- 2. Comply with the applicable editions of the following codes, regulations, and standards.

a. Codes and Regulations:

- 47 CFR 15 Code of Federal Regulations, Title 47, Part 15, Subpart B, Unintentional Radiators
- IEEE C2 National Electrical Safety Code (NESC)
- NFPA 70 National Electrical Code (NEC)

b. Industry Standards:

- ANSI C12.20 Electricity Meters 0.2 and 0.5 Accuracy Class
- IEEE C37.90.1 Surge Withstand Capability (SWC) Tests for Relays and Relay Systems Associated with Electric Power Apparatus
- UL 61010B-1 Electrical Measuring and Test Equipment; Part 1: General Requirements

c. Other Standards:

- ITI Information Technology Industry Council (formerly, CBEMA)
- NIST National Institute of Standards and Technology
- UL Underwriters Laboratories

3. Comply with the applicable reference Specifications as directed in the General Provisions and the Special Provisions.

D. Contractor Submittals

1. Submittals shall be in accordance with Section 01330, the General Provisions, the Special Provisions, and as specified herein.
2. Submittals shall include power monitor technical data sheets, installation manuals and/or user documentation manuals.

E. Quality Assurance

1. General:
 - a. Comply with the requirements specified herein and the applicable reference Specifications of the General Provisions and the Special Provisions.
 - b. The power monitors shall be calibrated at the factory using an instrument that is certified to have been calibrated using standards whose accuracies are traceable to the NIST.
2. Contractor's Qualifications:
 - a. Provide a qualified field service engineer as specified in Part 3, Article entitled "Installation" of this Specification.

F. Site Conditions

1. Operating conditions are as follows:
 - a. Indoors
 - b. Humidity: 50 to 85 percent
 - c. Ambient Temperature: 33°F - 120°F (Min – Max)
 - d. Altitude: Sea level
 - e. System Voltage: 480 V, 3-phase, 60 Hz, solidly grounded
 - f. Short Circuit Fault Withstand: 65,000 A
 - g. Seismic: Per Specification section 01640, Seismic Design of Equipment and Equipment Anchorage and as specified herein.

G. Warranty

1. See Section 16010.

PART 2 - PRODUCTS

A. Manufacturers

1. The power monitors shall be the latest version of Allen Bradley Power Monitor 5000 for installation in Allen Bradley MCCs.

B. Power Monitors

1. The power monitor shall be a multi-function 3-phase solid-state unit with ability to connect to either 3-phase 4-wire wye, or 3-phase 3-wire delta circuits.
2. Capabilities for voltage and current inputs to the meter shall conform to the following at a minimum:
 - a. The power monitor shall accept input of four independent voltage inputs and three independent current inputs of the stated capacity.
 - b. Voltage input shall be for direct connection to voltage circuits of up to 600 V ac without the use of potential transformers.
 - c. Voltage input shall have a dielectric strength of 4000VAC RMS for one minute.
 - d. Current input shall be rated for 5A, maximum current 6A.
3. The power monitor shall measure and report the following quantities at a minimum:
 - a. Voltage intervals shall be available simultaneously both phase to neutral and phase to phase, for all three phases.
 - b. Current, phase A, B, C, N-measured.
 - c. Watts (total and per phase), VARs (total and per phase), VA (total and per phase), Power Factor (total and per phase) and Frequency.
 - d. Accumulated Watt-hr, VA-hr, and VAR-hr; Watt-hr received; Watt-hr delivered.
4. Power monitor shall provide the following accuracies:
 - a. Voltage accuracy shall be +/-0.5% of readings.
 - b. Current accuracy shall be +/-0.5% of readings.
5. Provide (100 or 10Mbps) Ethernet/IP and Modbus TCP/IP port and protocol with all associated drivers and supporting hardware.
6. Power monitor shall provide waveform recording to capture and record transients and
7. The power monitor shall be field-programmable as follows:
 - a. Basic parameters: Voltage input scale, voltage mode (wye, delta, single phase), current input scale and communications setup parameters shall be programmable.
8. Current transformers input rated 5A each for all monitored phases. Shorting switches or test blocks shall be required for all CT inputs.
9. Power Transformers (PT) shall be provided for best accuracy

PART 3 - EXECUTION

A. Installation

1. The power monitors shall be completely wired and tested in accordance manufacturer's instructions. Provide a qualified field service engineer to supervise the installation, programming, and commissioning of the power monitors.
2. All current sensing connections to the power monitor shall be made using shorting type terminal blocks or test switches.

END OF SECTION

SECTION 16419

VARIABLE FREQUENCY DRIVES

PART 1 - GENERAL

A. The Requirement

1. The Contractor shall furnish all tools, equipment, material, and supplies and perform all labor required to install variable frequency drive (VFD) systems rated as indicated on the Drawings and specified herein.
2. The VFDs shall be located in the MCC, as applicable.
3. VFDs shall be rate heavy duty.

B. Related Work Specified Elsewhere

1. The requirements of the following sections and divisions apply to the Work of this Section. Other sections and divisions of the Specifications, not referenced below, shall also apply to the extent required for proper performance of this Work.
 - a. Section 01640, Seismic Design Equipment and Equipment Anchorage
 - b. Section 16080, Electrical Testing
 - c. Section 16480, Low-Voltage Motor Control
 - d. Division 16, Electrical, other applicable sections

C. Reference Specifications, Codes and Standards

1. All Work specified herein shall conform to or exceed the applicable requirements of the referenced portions of the following publications to the extent that the provisions thereof are not in conflict with other provisions of these Specifications.
2. Comply with the applicable editions of the following codes, regulations, and standards:
 - a. Codes and Regulations:
 - 29 CFR 1910 Code of Federal Regulations, Title 29, Part 1910, U.S. Occupational Safety and Health Standards (OSHA)
 - CCR California Code of Regulations, Title 8, Div. 1, Chap. 4, Subchap. 5, Electrical Safety Orders
 - CCR California Code of Regulations, Title 24, Building Standards Code
 - NFPA 70 National Electrical Code (NEC)

b. Industry Standards:

- IEEE 519 Recommended Practices and Requirements for Harmonic Control in Electrical Power Systems
- IEEE 1100 Recommended Practice for Powering and Grounding Electronic Equipment
- ISA 5.4 Instrument Loop Diagrams
- ISO 9001 Quality Management Systems - Requirements
- NEMA ICS 2 Controllers, Contactors and Overload Relays Rated 600 V
- NEMA ICS 7.1 Safety Standards for Construction and Guide for Selection, Installation, and Operation of Adjustable-Speed Drive Systems
- NEMA MG 1 Motors and Generators
- UL 467 Grounding and Bonding Equipment
- UL 508A Industrial Control Panels
- UL 508C Power Conversion Equipment

c. Other Standards:

- ANSI American National Standards Institute
- IEEE Institute of Electrical and Electronics Engineers
- NEMA National Electrical Manufacturers Association
- UL Underwriters Laboratories

3. Comply with the applicable reference Specifications as directed in the General Provisions and the Special Provisions.

D. System Description

1. Furnish and install complete, solid-state VFD systems as specified herein and indicated on the Drawings. This Specification describes variable speed motor control which includes the design, fabrication, testing, installation and support requirements for VFD systems for 3-phase squirrel cage rotor, induction motors.
2. Point of Common Coupling (PCC): The PCC shall be located at the secondary side of the transformer serving the VFD systems as shown on the Drawings.
3. The minimum available 3-phase short circuit current (SCCR) at PCC shall be 65 kA.

E. Contractors Submittals

1. Submittals shall be made in accordance with Section 01330, the General Provisions, Special Provisions, and as specified herein.
2. Shop drawings shall be project-specific. Submittals shall include the following:

- a. Layout Drawings: Layout drawings shall include enclosure dimensions, plan, front and side elevations, clearances and access details, weights, conduit entry location and dimensions, internal component arrangement, panel front device arrangement, nameplate legend, panel color, anchoring details, and heat dissipation values.
- b. Single-Line Diagrams: Single-line diagrams indicating all devices including circuit breakers, motor circuit protectors, contactors, instrument transformers, meters, relays, etc. Electrical ratings of all equipment and devices shall be clearly indicated on these diagrams.
- c. Schematic and Connection Diagrams: Schematic diagrams, per ISA 5.4, shall show system control, terminal block numbers, wire numbers, and wire colors. One schematic diagram shall be prepared for each motor-load combination.
 - (1) Internal connection diagrams shall show wiring of all devices inside the VFD, specific device location symbols and their respective legend terminal block arrangement, and wire numbers. External connection diagrams shall show interconnection of VFD with all external devices, identified by loop-tag numbers.
- d. Characteristic curves of fuses, circuit breakers, and other protective devices.
- e. Bill of Material: Bills of Material with catalog data sheets and manuals for all equipment and devices comprising the VFD system. Where catalog cuts and other brochures depicting product characteristics are supplied, annotate to show product to be provided on this Project. DISTRICT shall review and approve materials prior to procurement.
- f. List of Spare Parts: Complete list of recommended spare parts include item descriptions, recommended quantities, and unit costs. The recommended list shall be based on a maintenance plan where the DISTRICT will remove and replace failed items to the lowest replaceable module/component level.
- g. VFD design data necessary for electrical distribution system analysis: The analysis will be performed by the DISTRICT. VFD design data submitted shall include efficiencies, harmonic wave form, harmonic spectrum (up to 50 orders), transformer phase shift angle, rectifier firing angle, advance angle, and commutation reactance in percent of the rated reactance.
- h. Factory Inspection Plan, Factory Demonstration Test (FDT) Plan, and FDT Procedures.
- i. Seismic calculations: Seismic calculations for VFD structure and anchorage in accordance with Specification Section 01640 - Seismic Design Equipment and Equipment Anchorage.
- j. Certified Test Reports
- k. Installation, Operation, and Maintenance Instructions and Manuals
- l. Programming Guides and Manuals: For VFD system configuration, provide four (4) copies of latest programming software and guides/manuals. Submit to DISTRICT copies of all related software and licenses for the VFD for inclusion in the software library.
- m. Record Drawings: Drawings of each of the above types representing the as-built condition of the equipment and software shall be delivered with the equipment at the jobsite. Final or corrected As-Built Drawings shall be delivered 4 weeks after field

system acceptance and shall be included in the Installation, Operation, and Maintenance Manuals.

- (1) Programmable parameters shall be provided in hard copy and electronically (Microsoft Excel format) and shall include the following data fields: parameter, service, default setting, suggested setting, actual setting.
- n. Test documentation: Provide in a three-ring binder(s) within three weeks after the completion of the Project. The binder(s) shall be clearly marked on the outside front cover and spine with the words “Test Results”, the Project name, and the date of completion (month and year). Scanner tests shall be printed on 8-1/2-inch by 11-inch paper. When repairs and re-tests are performed, the problem found and corrective action taken shall be noted, and both the failed and passed test data shall be collected in the binder.

Quality assurance support information: Provide as specified in Part 1.G - Quality Assurance of this Specification.

F. Warranty Documentation

1. Comply with the requirements specified in Part 3.F – Maintenance and Part 3.G - Harmonic Measurement of this Specification.

G. Quality Assurance

1. General:
 - a. Comply with the requirements specified herein and the applicable reference Specifications of the General Provisions and the Special Provisions.
2. Manufacturer Qualifications:
 - a. For the equipment specified herein, the manufacturer shall be ISO 9001-certified.
 - b. VFD manufacturer shall maintain, as part of a national network, engineering service facilities to provide 24-hour/day emergency service calls.
 - c. Provide the following supporting information:
 - (1) The location of repair facilities where drive system components would be repaired
 - (2) The location(s) nearest to Laguna Niguel, California, where spare parts are stocked
 - (3) VFD manufacturer information guaranteeing 72 hours turnaround time after receipt at the repair facility for the repair and return of a failed part.

Comply with the requirements for the certifications, licenses, training, skills, experience, and other qualifications specified in Part 3.E - Field Quality Control and Part 3.F - Maintenance of this Specification.

H. Operating Conditions

1. The following operating conditions are applicable to the VFD:

- a. Humidity: 50 to 95 percent
- b. Ambient Temperature: 75 to 95 Degrees F
- c. Altitude: Sea level
- d. Power Supply: 480V, 3-phase, 60 Hertz
- e. Short circuit fault withstand: 65kAIC.

I. Warranty

1. The Contractor shall provide a system warranty covering the installed VFDs against defects in workmanship, components, and performance, and follow-on support after Project completion.
2. The Contractor shall warrant the VFDs against defects in workmanship for a period of one year from the date of system's Final Acceptance. The warranty shall cover all labor and materials necessary to correct a failed portion of the system and to demonstrate performance within the original installation Specifications after repairs are accomplished. This warranty shall be provided at no additional cost to the DISTRICT.
3. After installation, the Contractor shall submit all documentation to support the warranty in accordance with the manufacturer's warranty requirements, and to apply for said warranty on behalf of the DISTRICT.

PART 2 - PRODUCTS

A. Manufacturer

1. All VFD systems for the Contract shall be supplied by the same manufacturer.
2. Manufacturer: Rockwell Automation (Allen Bradley) 753 or 755 Series is DISTRICT's standard.

B. Variable Frequency Drive System

1. The VFD shall be UL listed and show the UL label.
2. Each VFD shall be a complete alternating current electric drive system including hardware, software, and technical data necessary to accomplish variable speed operation of an induction motor and load combination in accordance with the requirements as indicated on the Drawings and as described in these Specifications.
3. Contractor shall be responsible for the successful application and operation of the drive combined with the inverter-rated motor and driven equipment. This includes the responsibility for determining all load, torque, speed, and performance requirements from the respective sources and integrating these into a VFD system that fulfills the requirements of this Specification.
4. The complete VFD system shall be designed to withstand the mechanical forces exerted during short circuit conditions.

- 5. The VFD system shall be suitable to operate, at times, on a limited power source engine-generator set. The system when operating on this source shall also conform to waveform distortion limits for normal operation as specified in Part 2.I - Harmonic Distortion of this Specification.
- 6. All necessary motor and drive parameters together with specific control and protection functions shall be programmable via a keypad. Control and sequence logic shall be designed such that the motor-load combination can be operated in the manual mode upon control and sequence logic failure, and that all necessary personnel and equipment safety interlocks shall remain effective.

C. Design Requirements

- 1. The VFD shall consist of a 6-pulse full-wave bridge rectifier, a direct current link, a pulse-width-modulated inverter, line and load reactors. The VFD shall be of non-active-front-end (voltage source) design using Pulse Width Modulation (PWM) and Insulated Gated Bipolar Transistor (IGBT) technology. Active front end (current source) design shall not be acceptable. The inverter shall invert the direct current voltage into an alternating current voltage and frequency proportional to the desired speed. This alternating current voltage and frequency shall both vary simultaneously at a constant "Volts-Per-Hertz" ratio to operate the induction motor at the desired speed.
- 2. Provide each VFD with an adjustable type "MCP" main circuit breaker as indicated on the Drawings which can be padlocked in the OFF position. Provide line reactors as shown on the Contract Drawings, having a minimum 3 percent reactance. Reactors shall be mounted in the VFD enclosure. 480V/120V control transformer with Primary/Secondary fuses.
- 3. The drive shall operate the motor and produce full rated nameplate horsepower at the motor output shaft without exceeding rated total temperature including the additional temperature increment that constitutes the motor service factor. Motor shall retain its service factor of 1.0 when operated by the VFD. The drive shall operate with a minimum 95 percent input power factor at speeds between 30 percent and 100 percent of rated speed.
- 4. For lead lengths exceeding 500 feet, the VFD assembly shall include the capability to provide transient voltage protection at the motor by means of a motor terminator or output sine wave filter. Stand-alone line reactors shall not be acceptable.
- 5. Power (Load) is the total 3-phase power delivered to the motor, measured at the output terminals of the drive system. Power (Supply) is the total electrical power delivered to the drive system, measured at the input terminals of the VFD including filters, line reactors, transformers, harmonic distortion attenuation equipment and the other drive assembly devices. Power (Supply) shall include power input required for auxiliary equipment (e.g., controls, cooling fans, air-conditioning, pumps) for complete system operation.
- 6. The overall drive system efficiency shall be a minimum of 96 percent when operating the specified motor-load combination at rated voltage, frequency, and current. The efficiency shall exceed 90 percent when operating at 50 percent speed and load. This efficiency shall be calculated as follows:

$$Efficiency (\%) = \frac{Power (Load)}{Power (Supply)} \times 100$$

7. The VFD system shall provide smooth, stepless changes in motor speed and acceleration over the entire operating speed range from minimum to maximum speed (revolutions per minute).
8. The VFD system shall maintain a desired output frequency (set-point) with a steady state accuracy of 0.5 percent of rated frequency of 60 Hertz for a 24-hour period. The drive system shall achieve a desired output frequency (setpoint) with a repeatability of 0.1 percent of rated frequency of 60 Hertz.
9. VFD shall have an automatic current limit feature to control motor currents during startup and provide a "soft start" torque profile for the motor-load combination. The VFD shall also limit current due to motor winding or motor lead phase-to-phase short circuit or phase-to-ground short circuit. The current limit protection setting shall be field adjustable.
10. A door-mounted membrane keypad with integral two-line, 24-character LCD display shall be provided, capable of controlling the VFD and setting drive and motor parameters. The keypad module shall contain a self-test software program which may be activated to verify proper keypad operation.
11. The reset button shall not be included in the VFD, unless otherwise requested by DISTRICT.
12. The system shall be capable of operating the specified load continuously at any speed within the operating speed range of 0 percent to 100 percent of rated speed. The minimum and maximum continuous operating speeds shall each be adjustable within this speed range. The VFD shall provide for field adjustment of these set points.
13. Drive system controls shall be microprocessor-based and have controlled linear acceleration capability to ramp up and down the speed (revolutions per minute) of the motor-load combination from the minimum selected operating speed to the maximum selected operating speed at individual adjustable rates. Provide 3 field-adjustable speed set points for the VFD to skip equipment resonant frequencies. Provide controlled linear deceleration capability. The acceleration and deceleration time limits shall be field adjustable to values up to 120 seconds.
14. Voltage unbalance between phases of the VFD output shall not exceed 3 percent of the instantaneous values with balanced input voltage. The VFD system shall continuously monitor the output voltages and generate an alarm condition when the unbalance exceeds 3 percent. The system shall detect and generate a separate alarm for loss of any output phase voltage (single-phasing). Phase unbalance shall be as defined by NEMA MG 1.
15. The VFD system shall operate continuously without interruption of service or damage to equipment during transient input voltage variations of plus or minus 10 percent for a duration of 15 cycles. Unacceptable voltage fluctuations on the supply bus shall cause undervoltage or overvoltage protection to trip the drive system. VFD output voltage regulation shall be plus or minus 2 percent.
16. The VFD shall be capable of supplying continuously an output motor load RMS current equal to 100 percent of the motor full load RMS current when operated from an undistorted sine wave source. This 100 percent RMS value shall include all harmonic content in the inverter output current while producing full nameplate horsepower from the motor. Motor overcurrent protection shall be provided.

17. The audible noise (sound pressure) level of a motor when operated from no load to full load with the VFD described herein shall not increase more than 5 dbA above its noise level when operated at constant rated speed from a utility power source without the VFD. Audible noise shall be measured in a free field at 3 feet in all directions from the motor.
18. Activation of the lockout-stop pushbutton at the motor shall disable operation of the VFD including operation by the keypad in the local mode, remote mode and, if bypass contactor is used, the bypass control mode.
19. The VFD shall operate in a solidly grounded power distribution system as a normal power source. The VFD shall continue to operate without tripping when the system feeding the VFD is transferred and retransferred by an external automatic transfer switch (ATS) or a bus transfer scheme from the normal power source to a solidly grounded standby power source. The continued operation of the VFD after the transfer and retransfer shall not require operator intervention.

D. System Features and Conditions

1. Include Human Machine Interface (HMI) to provide the following:
 - a. On-line diagnostics, with an automatic self-check feature that shall detect a VFD failure that affects motor operation and generate an alarm with a form "C" output contact rated for 2A, 250V ac suitable for interfacing into an alarm annunciation system. All displays and diagnostics shall be in narrative English.
 - b. An RS-232 communication for connection to a laptop computer. The "First Out" failure indication and alarm shall be provided.
 - c. Ethernet TCP/IP connection which shall be able to upload and download all the operation/performance/programming parameters to an Allen Bradley Control Logic PLC communication module. The Contractor shall provide the DISTRICT with a register I/O list which defines the Modbus TCP/IP register locations of each parameter, its range of values and value as finalized after setup.
 - d. A door-mounted programming keypad to input set points and mode and sequence programming data and display shall provide for the following, at a minimum:
 - (1) Input Voltage
 - (2) Output Voltage
 - (3) Output Current
 - (4) Output Frequency
 - (5) Alarm Read-out
 - (6) Alarm Reset button
 - (7) Event and Diagnostic Recorder
2. In addition to HMI, controls and indicators to accomplish operation and maintenance functions shall be located on the VFD equipment assembly as specified herein and indicated on the Drawings. Status displays on the LCD/LED panel shall be in English units or narrative

English. No codes shall be acceptable. All the shutdown conditions and/or alarms which will prevent VFD from running shall be displayed on the cabinet with indicating lights.

3. Motor protection relay and motor instrumentation shall be compatible. If not, provide all necessary interface with the DISTRICT's written acceptance.
4. Devices to be mounted on the front door of the VFD Section shall include the following:
 - a. Digital Output Speed Indicator: 0 to 100 percent speed
 - b. Manual Speed Control (separate three-quarter turn potentiometer with Scale 0-100 percent speed in addition to the keypad)
 - c. 20-HMI-A6, with a NEMA 1 bezel kit
 - d. Hand-off-auto selector switch
 - e. Speed potentiometer
 - f. Elapse time meter
 - g. White, push to test, control power indicating light
 - h. White, push to test, VFD running indicating light;
 - i. Red, push to test, VFD fault indicating light;
 - j. Door ventilation filters
 - k. Control switches, indicating lights, and other devices as shown on the Drawings
5. All interlocks shall be hard-wired using relays. Use of PLC for interlocks shall not be allowed.
6. All contacts to outside equipment and/or PLC shall be Form "C" rated 2A, 250V ac.
7. All I/O interfaces with DISTRICT's PLC shall be hard-wired and provide 120V ac wetting voltage. Status, alarm, and control signals to and from DISTRICT's PLC shall be as shown on the Drawings.
8. VFD system shall provide an output signal via Ethernet that is proportional to the drive output frequency (speed in rpm) for use as speed feedback or control and remote speed indication. Retransmitted signal from indicator shall not be acceptable.
9. The controls shall accept the input increase/decrease command with a resolution that permits incremental changes in speed, revolutions per minute, equal to or less than 0.1 percent of rated speed.
10. When the HAND-OFF-REMOTE switch is in the HAND position, the VFD shall reference the potentiometer voltage signal for speed command. When the HAND-OFF-REMOTE switch is in the REMOTE position, the VFD shall reference the Ethernet PLC signal for speed command. The VFD shall be capable of successfully switching the speed command reference as controlled by the selector switch without stopping.
11. Upon restoration of normal or standby power and after an adjustable time delay (0-30 seconds); the VFD system shall automatically restart and then ramp up to speed as required by the control system. The plant operator shall not be required to reset the system manually

after a shutdown caused by a power outage. With longer power outages VFD shall restart as controlled by the PLC or manually at the VFD.

12. The VFD shall have a programmable parameter which allows the independent setting of the minimum speed as well as other speed-related settings such as frequency skipping, etc.
13. Provide VFD system with transmitted and received radio interference protection.
14. All the VFD system programming including that of the micro-processor protective relays shall be stored on EEPROM.
15. The VFD shall have Hold Zero Speed feature by applying a low-voltage direct current to the motor windings to keep the motor from spinning after power is removed. Operate the remote located Lockout-Stop (LOS) pushbutton shall disable the Hold Zero Speed feature so that no power is available at the motor terminals.
16. Indicating lights shall be push-to-test, LED, transformer type.

E. Enclosures and Material

1. Installed in the MCC.

F. Control Wiring and Terminal Blocks

1. All internal control wiring shall be flexible, stranded copper conductors, 14 AWG minimum, with type TBS or SIS (cross-linked thermosetting polyethylene) insulation. All wiring shall be bundled and supported by plastic strip lock straps or run in a wire duct. Wire harnesses shall be anchored by mechanical means or two-part epoxy glue. Adhesive "stick-on" type bundle supports shall not be allowed.
2. Terminal blocks shall be clearly labeled to identify connection points for field wiring.
3. Provide a minimum of 25 percent spare terminals. Use only single-deck terminal blocks.
4. Each end of the internal interconnecting wire shall be identified by a marker showing the wire number. Wire numbers shall match the manufacturer's detailed connection diagrams. All wires originating from the same electrical node or point shall carry the same wire number. Wire markers shall be machine printed, white, shrink-on type sleeves slightly shrunk to prevent slipping down the wire but loose enough to allow them to be rotated.
5. No more than 2 wires (including field wires) shall be terminated at any terminal. Provide sufficient terminals to terminate all wires especially X2 terminals.

G. Space Heaters

1. Motor space heaters shall be powered by the CPT in the related VFD and controlled by an external power source such as a lighting panel, so that the motor space heater shall be energized when the motor is stopped and de-energized when the motor runs. The contact shall be rated to carry the space heater current.

2. Space heater for the VFD enclosure shall be required. Contractor shall provide temporary power and heaters, acceptable to the DISTRICT, to prevent condensation in the enclosure during storage, construction, and until the electrical room ventilation is in operation.

H. Nameplates

1. Nameplates shall be furnished as specified in Specification Section 16075 - Electrical Identification Nameplates and Warning Signs.

I. Harmonic Distortion

1. The harmonic distortion values contributed by operation of all VFD motor-loads operating at full load shall be:
 - a. Maximum Allowable Harmonic Voltage Distortion (HVD) Contribution: 5 percent of the fundamental for total distortion and 3 percent for the individual harmonics per the latest edition of IEEE 519.
 - b. Maximum Allowable Total Harmonic Current Demand Distortion (THID) Contribution: 8 percent of the combined load current of the main feeder supplying all 480-volt loads.

J. Control Cards

1. Allen Bradley 753 Power Flex Drive, rated heavy duty.
2. 750 Dual Port Ethernet Card.
3. 115 Volt I/O Module.

K. Motor Protection (NOT USED)

PART 3 - EXECUTION

A. Shop Inspection and Factory Demonstration Test

1. The DISTRICT will inspect and witness Factory Demonstration Test (FDT) of the VFD at the manufacturer's factory for conformance with the Contract Documents. The Contractor shall provide the DISTRICT a minimum of a two-week advance notice before the equipment is ready for inspection and FDT and the following documents:
 - a. A complete set of up-to-date shop drawings incorporating or resolving all the DISTRICT's comments
 - b. Manufacturer's inspection and factory test plans and test procedures. Expand the procedures as needed to make them sufficient to demonstrate that the VFD meets all requirements detailed in PART 2 of this Specification section.
2. Before the test, a meeting shall be held to review the test procedures and determine that all the drawings and documents for the equipment are up-to-date.
3. After the test, a meeting shall be held to review the punchlist items and corrective actions.

4. The Contractor shall be responsible for factory demonstration test (FDT) performance. If the equipment being inspected and/or tested is not ready on Contractor's specified date, or does not meet the test criteria, or does not meet the Contract requirements, re-inspection and/or retesting of the equipment may be required. The Contractor shall be responsible for the cost and schedule impacts, including the cost of transportation, labor, and accommodations of the engineer associated with re-inspection and/or re-witness the FDT. The DISTRICT's costs incurred for re-inspection and/or retesting will be assessed through a deductive Contract change order.

B. Source Quality Control

1. Factory Testing

- a. Factory-test the complete VFD system in accordance with IEEE and NEMA standards, the requirements of the Contract Documents.
- b. The VFD system shall be tested for a minimum of 30 minutes under varying motor loads from 25 to 50 to 100 percent of full load.
- c. Acceptance of a shop test shall not relieve Contractor from requirements to meet field installation tests under specified operating conditions, nor shall the inspection relieve the Contractor of responsibilities.
- d. Drive system shall not be shipped from the manufacturing and assembly facility until the acceptance tests have been completed and the results have been accepted by the DISTRICT in writing.

C. Installation

1. During storage, installation, and before the electrical room ventilation system is in operation, the Contractor shall install temporary power and space heaters to prevent condensation inside the VFD system.

D. Programming of the VFD

1. The Contractor shall have the sole responsibility for installing and configuring the VFD software for proper operation. The Contractor shall also be responsible to ensure that the various VFD communication links fully communicate with DISTRICT's PLC system.

E. Field Quality Control

1. Provide the services of an experienced, factory-trained technician or service engineer of the VFD manufacturer at the jobsite for minimum of 2 days for startup of each VFD beginning at a date acceptable to the Contractor and the DISTRICT. The technician shall be on duty at the site for at least 8 hours per day and shall be available 24 hours per day when required to advise concerning special problems with equipment and systems. VFD 1, VFD 2 and VFD 3 will be started on separate days due to required construction sequencing.
2. Contractor shall provide factory-trained service personnel to inspect the VFD installation, make final adjustments and operational checks, and prepare a Certificate of Proper Installation.

3. The Contractor shall perform and submit the results of a final comprehensive field performance survey after equipment installation.

F. Maintenance

1. Tools and Equipment: VFD manufacturer shall identify and supply necessary test equipment and special tools that are unique to performing maintenance or repair tasks of the drive system supplied.
2. Field Services: Contractor shall describe the field service system available to support the proposed VFD system. At a minimum, describe the following:
 - a. Type of technical support available (e.g., system engineering and technician).
 - b. Location of field service personnel (maximum 100 miles).
 - c. Field service daily rates in dollars per hour and dollars per day.
 - d. Guaranteed response times to service requests.

G. Harmonic Measurement

1. The Contractor shall field measure actual harmonic distortion to verify compliance with harmonic content requirements per this Specification during acceptable full-load operation of all the drives.
2. Measurements shall include harmonic voltage and current spectra and individual and total harmonic distortions.
3. As part of the specified harmonic studies and measurements for this Project, perform frequency scan analysis to identify resonance conditions in the electrical distribution system and correct them at no additional cost to DISTRICT.

H. Field Tests

1. Field tests shall be in accordance with Specification Section 16080 - Electrical Testing.

I. Training

1. The Contractor shall conduct on-site training for DISTRICT personnel in accordance with Specification Section 01820 - Training of DISTRICT Personnel.

END OF SECTION

SECTION 16431

ELECTRICAL SYSTEM ANALYSES AND MEASUREMENTS

PART 1 - GENERAL

A. The Requirement

1. This Section specifies power system analyses and measurements for the Contract.
2. The work of this Section includes providing a short circuit study, a protective device coordination study and arc flash analysis for the electrical power system. The studies shall include the electrical distribution system for normal power sources and arc flash analysis.
3. Adjust all circuit breaker settings in accordance with the study results. Apply arc flash warning labels as needed to all electrical equipment.
4. Arc flash analysis shall provide two settings for the current limiting main circuit breaker when maintenance position is selected.

B. Related Work Specified Elsewhere

1. The requirements of the following sections and divisions apply to the work of this Section. Other sections and divisions of the Specifications, not referenced below, shall also apply to the extent required for proper performance of this work.
 - a. Electrical General Provisions: 16010
 - b. Electrical Testing: 16080
 - c. Division 16, Electrical, other applicable sections

C. Reference Specifications, Codes and Standards

1. All work specified herein shall conform to or exceed the applicable requirements of the referenced portions of the following publications to the extent that the provisions thereof are not in conflict with other provisions of these Specifications.
2. Comply with the applicable editions of the following codes, regulations, and standards:
 - a. Codes and Standards
 - NFPA 70 National Electrical Code (NEC)
 - b. Industry Standards
 - IEEE 141 Recommended Practice for Electrical Power Distribution for Industrial Plants
 - IEEE 242 Recommended Practice for Protection and Coordination of Industrial and Commercial Power Systems
 - IEEE 519 Recommended Practices and Requirements for Harmonic Control in Electrical Power Systems

IEEE C37.010	Application Guide for AC High-Voltage Circuit Breakers Rated on a Symmetrical Current Basis
IEEE C37.13	Low-Voltage AC Power Circuit Breaker Used in Enclosures
IEEE 1584	Guide for Performing Arc Flash Hazard Calculations

3. Comply with the applicable reference Specifications as directed in the General Requirements and the Additional General Requirements.

D. Contractor Submittals

1. Submittals shall be in accordance with the General Requirements, Additional General Requirements, and as specified herein.
2. Submittals shall include the following:
 - a. Any proposed substitutions to the protection scheme, equipment, and protective devices.
 - b. Complete nameplate data for all power distribution equipment and mechanical equipment including exact model number, serial number, ratings, and design data.
 - c. Protective device time current characteristic curves, specifications, type, model, and data.
 - d. Actual lengths and size of all power distribution cables installed.
 - e. Harmonic measurements.

E. Quality Assurance

1. Comply with the requirements specified herein and the applicable reference Specifications of the General Requirements and Additional General Requirements.
2. Short circuit studies, protective device evaluation studies, and protective coordination studies shall be performed by an electrical testing service regularly engaged in short circuit and protective device coordination studies having at least one successful study of comparable size and complexity completed in the recent past.

PART 2 - PRODUCTS

A. Study Reports

1. The results of the power system study and measurements shall be summarized in a final report, signed by the professional electrical engineer registered in the State of California responsible for the studies. Six bound copies of the final report shall be submitted and shall include the following:
 - a. Single-line diagram with maximum available fault current.
 - b. Tabulation and identification of protective devices on the single-line diagram.
 - c. Test instrumentation, condition and connections, as applicable, for each study.
 - d. Arc Flash Study.

2. The report shall include a single line diagram of the power system. The Contractor may request and utilize the DISTRICT's AutoCAD file single line diagram. This diagram shall identify components included in the study and the ratings of power devices including transformers, circuit breakers, relays, fuses, busses, and cables. The study shall include written data regarding maximum available short circuit current, voltage, and X/R ratio as provided by the utility company.

B. Short Circuit Study

1. The short circuit study shall be performed with the aid of a computer program (SKM software) complying with ANSI C 37.5, IEEE Standard 242, and IEEE Standard 141.

C. Protective Device Coordination Study

1. A protective device evaluation study shall be performed to determine the adequacy of circuit breakers, automatic transfer switch, and other items. Any problem areas or inadequacies in the equipment due to prospective short-circuit currents shall be promptly brought to the DISTRICT's attention in writing but in no case more than 7 days after discovery.
2. The time/current coordination curves for the power distribution system shall include, on 5-cycle log-log graph paper, at least the following:
 - a. Time/current curves for each circuit breaker showing graphically that the settings will provide protection and selectivity within industry standards. Each curve shall be identified, and tap and time dial settings shall be shown.
 - b. Time/current curves for each device shall be positioned to provide the maximum selectivity to minimize system disturbances during fault clearing. Where selectivity cannot be achieved, the DISTRICT shall be promptly notified of the cause in writing but in no case more than 7 days after discovery.
 - c. Time/current curves and points for cable and equipment damage.
 - d. Circuit interrupting device operating and interrupting times.
 - e. Maximum fault values.
 - f. Sketch of bus and breaker arrangement.
 - g. Magnetizing inrush points of transformers.
 - h. Compliance with Code requirements and proper coordination intervals and separation of characteristics curves.
3. ARC Flash Hazard Analysis
 - a. The Contractor shall provide an arc flash hazard analysis. The flash hazard analysis shall cover the service entrance switchboard. It shall include the Flash Protection Boundaries (FPB), the timing required for the main circuit protective device to operate to clear the fault, the arc-flash energy in cal/cm² available, and the level of Personal Protective Equipment (PPE) necessary to work within the FPB. The analysis shall be based on latest IEEE 1584.

- b. Two settings for the adjustable current limiting main circuit breaker in the MAINTENANCE position shall be calculated:
 - (1) One setting shall be to limit the downstream current so the required PPE will be LEVEL 1. This value shall be set on the main circuit breaker. All equipment and floor markings shall be for PPE 1.
 - (2) The second setting shall be to limit the downstream current so the required PPE will be LEVEL 0.
- c. The arc-flash analysis shall also include the arc-flash warning label, required under NEC Article 110.16, which shall contain the following:
 - (1) Flash protection boundary
 - (2) Incident energy at 18 inches expressed in cal/cm²
 - (3) PPE 1 required
 - (4) Voltage shock hazard
 - (5) Limited shock approach boundary
 - (6) Restricted shock approach boundary
 - (7) Prohibited shock approach boundary.
 - (8) Equipment name
- d. The main circuit breaker shall be equipped with the following label:

WARNING

PPE LEVEL 1 IS REQUIRED WHEN THE MAINTENANCE MODE SETTING IS ____

PPE LEVEL 0 IS AVAILABLE WHEN THE MAINTENANCE MODE SETTING IS ____

- e. A sample arc flash and shock hazard warning label is shown below.

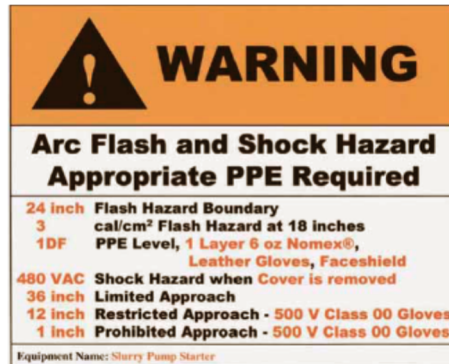

Sample Label

PART 3 - EXECUTION

A. Protective Device Testing, Calibration and Adjustment

1. Provide the services of a qualified field engineer and necessary tools and equipment to test, calibrate, and adjust the circuit breaker trip devices and other equipment as recommended in the power system study.
2. The system shall be tested in accordance with Section 16080, Electrical Testing.
3. Provide a demonstration of proper operation of all equipment and metering.

B. Setting and Testing of Adjustable/Programmable Protective Devices

1. The testing organization shall set/program and test the adjustable/programmable protective devices in the field according to applicable NETA and manufacturer's requirements.
2. Contractor shall provide all software and hardware required to set or program devices.
3. The protective devices shall be tested for operation after setting and programming.

C. ARC Flash Markings

1. Install arc flash and shock hazard warning labels on electrical equipment wherever indicated by arc flash analysis.
2. Install WARNING Arc Flash Hazard Appropriate PPE Required Category 0 arc flash hazard when operating controls with covers on or enclosure doors on label for all electrical equipment. Brady Catalog #121107 or equal.
3. Install DANGER Arc Flash and Shock Hazard Appropriate PPE Required FLASH PROTECTION Flash Hazard Category 1 when NORMAL/MAINTENANCE switch on the main disconnect is in the MAINTENANCE position label where arc flash analysis indicates the label is required. Custom label, similar to Brady Catalog #121086 or equal.

END OF SECTION

This Page Intentionally Left Blank

SECTION 16441

METER AND MAIN DISCONNECT

PART 1 - GENERAL

A. The Requirement

1. General: The Contractor shall provide all tools, materials, equipment, and labor necessary for the furnishing, construction, installation, testing, and operation of all electrical Work necessary to provide a complete and operable system, all in accordance with the requirements of the Contract Documents.
2. Contractor shall confirm dimensions in the field as well as contract documents for switchboard.

B. Related Work Specified Elsewhere

1. The requirements of the following sections and divisions apply to the Work of this section. Other sections and divisions of these Specifications, not referenced below, shall also apply to the extent required for proper performance of this Work.
 - a. Division 16, Electrical, other applicable sections.

C. Reference Specifications, Codes, and Standards

1. All Work specified herein shall conform to or exceed the applicable requirements of the referenced portions of the following publications to the extent that the provisions thereof are not in conflict with other provisions of these Specifications.
2. Comply with the applicable editions of the following codes, regulations, and standards.
 - a. Other Standards: All electrical equipment and materials shall be designed, manufactured, and installed in accordance with the latest published edition of the applicable standards of the following standard-making organizations. Specific standards are identified in the various sections for specific types of equipment and materials:

ANSI	American National Standards Institute
CSA	Canadian Standards Association
FM	FM Approvals (formerly, Factory Mutual Research Corporation)
ICEA	Insulated Cable Engineers Association
IEEE	Institute of Electrical and Electronics Engineers
NECA	National Electrical Contractor's Association
NEMA	National Electrical Manufacturers Association
NETA	InterNational Electrical Testing Association
UL	Underwriters Laboratories

3. The construction and installation of all electrical equipment and materials shall comply with all provisions of the codes, regulations and standards specified above, as applicable, and other applicable federal, state and local codes, laws and regulations.
 - a. Local Utility Company:
 - (1) San Diego Gas & Electric (SDG&E)
 - (2) Southern California Edison (SCE)
4. All Work specified herein shall conform to or exceed the applicable requirements of the NFPA 70 - National Electric Code (NEC) and California Electrical Code. Where provisions of the NFPA 70 and the California Electrical Code are in conflict, the more stringent provisions, as interpreted by the applicable authority having jurisdiction, shall govern. Where a local code or ordinance is in conflict with the NFPA 70 and California Electrical Code, the provisions of said local code ordinance shall take precedence.
5. Comply with the applicable reference Specifications as directed in the General Provisions and the Special Provisions.

D. Contractor Submittals

1. Submittals shall be in accordance with the General Provisions, the Special Provisions, and as specified in Specification Section 01330. Submittals shall also include the following:
 - a. Drawing showing the method for extending the existing conductors should they be short.

E. Quality Assurance

1. General:
 - a. Comply with the requirements specified in Specification 16010 and the applicable reference Specifications of the General Provisions and the Special Provisions.
 - b. Tests: The Contractor shall make all tests as specified Section 16080, Electrical Testing. Operational testing shall be performed on all equipment furnished to confirm they function as intended.
 - c. Any material and equipment that fails the field tests shall be replaced, repaired, and retest until the specified requirements are met.

F. Delivery, Storage, and Handling

1. Provide a temporary enclosure heater for the service entrance while the service entrance is deenergized.

PART 2 - PRODUCTS

A. General

1. All equipment furnished by the Contractor shall be listed by and bear the label of UL, FM, or an OSHA-recognized testing laboratory.

2. All electrical equipment and materials shall be capable of operating successfully at full-rated load, without failure, at an ambient temperature of 40° C (104° F). Provide NEMA 1 gasketed or NEMA 3R rated equipment where indicated on the Contract Drawings.
3. Equipment for Power Metering by Utility Company
 - a. Meters will be furnished by the Utility Company.
 - b. Current-Transformer Cabinets: Comply with requirements of electrical-power utility company.
 - c. Meter Sockets: Comply with requirements of electrical power utility company.
 - d. Meter Sockets: Steady-state and short-circuit current ratings shall meet indicated circuit ratings.
 - e. Modular Meter Center: Factory-coordinated assembly of a main service pull section, meter section, main current limiting circuit breaker, internal wireways, all arranged in stacked or adjacent vertical sections. Assembly shall be complete with interconnecting buses and other features as specified below.
 - (1) Basis-of-Design Product: Subject to compliance with requirements, provide Eaton Electrical Inc.; Cutler-Hammer Series G Arc Flash Reduction Circuit Breaker with Digitrip 310+ trip unit or comparable product by one of the following:
 - (a) General Electric Company; GE Consumer & Industrial - Electrical Distribution.
 - (b) Siemens Energy & Automation, Inc.
 - (c) Square D; a brand of Schneider Electric.
 - (d) IEM Power Systems
 - (2) Comply with requirements of utility company for meter center.
 - (3) Housing: NEMA Type 1 gasketed or NEMA 3R enclosure.
 - (4) Minimum Short-Circuit Rating: 65,000 Amps symmetrical at rated voltage.
 - (5) Main Disconnect Device: Arc Flash Current limiting circuit breaker with accessories.
 - (6) Meter Socket: Rating coordinated with indicated tenant feeder circuit rating.

B. ARC Flash Current Limiting Circuit Breaker

1. The arc flash current limiting circuit breaker shall have as a minimum the following characteristics:
 - a. Power circuit breaker meeting the requirements of UL 1066.
 - b. Voltage, current, frame size, current interrupting capacity as shown on the Contract Drawings. Minimum life of 15,000 mechanical operations, 7,500 electrical operations.
 - c. Minimum 2 spare Form C breaker status contacts.
 - d. All internal power supplies, actuation & mounting hardware, and other accessories required for a complete and operable unit.

2. The breaker trip unit shall meet the following requirements:
 - a. Digital Based Control: Long Term Delay, Short Term Delay, Instantaneous adjustable trip settings. Adjustable Ground Fault Delay where indicated on the Contract Drawings.
 - b. System Diagnostics and Monitoring: Cause-of-trip LED; Magnitude of trip information; Current (%); Remote signal contacts all displayed on an integral Liquid Crystal Display.
 - c. Controls: Provide two position low signal level selector switch marked MAINTENANCE and NORMAL. Provide amber LED indicator light marked IN MAINTENANCE MODE. Switch shall be located on the same panel as the main circuit breaker. The indicator light shall be located on the outside door of the enclosure to be visible when the door is closed.
 - d. Arc Flash Reduction System: Capable of reducing downstream PPE to Level 1 by reducing the instantaneous fault current trip rating when a MAINTENANCE/NORMAL selector switch is placed in the MAINTENANCE position. An indicator light operated by the trip unit shall illuminate when the selector switch is in the MAINTENANCE position.

C. Digital Metering Equipment

1. Volt Meter: Where indicated on the drawings, provide a microprocessor based line of multifunction, power meters, designated device equal to Eaton type IQ-250, Square D, GE or equal. The meter device shall be UL listed. All meters shall have the following ratings, features, and functions, unless a specific meter type is designated.
 - a. Meter shall be designed for Electrical Measurement on 3 phase power systems. The Meter shall support 3-Element Wye, 2.5 Element Wye, 2 Element Delta, 4 wire Delta systems.
 - b. Meter surge withstand shall conform to IEEE C37.90.1 and ANSI C62.41 (6KV)
 - c. The meter shall be user programmable for voltage range to any PT ratio.
 - d. The meter shall have a burden of up to .36VA per phase, Max at 600V, 0.014VA at 120 Volts.
 - e. The meter shall accept a direct voltage input range of up to 576 Volts Line to Neutral, and a range of up to 721 Volts Line to Line.
2. The meter shall have the following additional ratings and features:
 - a. Fault Current Withstand shall be 100 Amps for 10 seconds, 300 Amps for 3 seconds, and 500 Amps for 1 second.
 - b. Meter to accept a pass-through wire gauge dimension of 0.177" / 4.5 mm.
 - c. All inputs and outputs shall be galvanically isolated to 2500 Volts AC.
3. The meter shall have an accuracy of +/- 0.1% or better for volts. The meter shall meet the accuracy requirements of IEC687 (class 0.2%) and ANSI C12.20 (Class 0.2%).
 - a. The meter shall provide true RMS measurements of voltage, phase to neutral and phase to phase.

- b. The meter shall provide sampling at 400+ samples per cycle on all channels measured readings simultaneously.
 - c. The meter shall utilize 24-bit Analog to Digital conversion.
 - d. Meters shall provide Volts.
4. The meter shall include a three-line, bright red, .56” LED display.
- a. The meter shall fit in both DIN 92mm and ANSI C39.1 Round cut-outs.
 - b. The meter must display a % of FULL SCALE on the front panel to provide an analog feel. The % FULL SCALE shall have not less than 10 segments.
5. Meter shall be a traceable revenue meter, which shall contain a utility grade test pulse allowing power providers to verify and confirm that the meter is performing to its rated accuracy.
6. The meter shall provide user configured fixed window or sliding window demand. This shall allow the user to set up the particular utility demand profile.
- a. Voltage shall provide an instantaneous max and min reading displaying the highest surge and lowest sag seen by the meter.
7. The meter shall be capable of operating on a power supply of 120 Volts AC
- a. Meter AC/DC power supply shall accept burden of 10VA max.
8. Meter shall provide update rate of 1 sec parameters.
9. The meter shall have I/O expandability through two Option card slots on the back.
- a. The cards shall be capable of being installed in the field, without removing the meter from installation.
 - b. The meter shall auto-detect the presence of any I/O Option cards.
 - c. The Option card slots shall accept I/O cards in the following formats: Two Relay Outputs/2 Status Inputs Card.
 - d. The Two Relay Outputs/2 Status Inputs Option Card shall provide the following features:
 - (1) Status Inputs – Wet/Dry Auto Detect up to 300 VDC
 - (2) Set delays and reset delays
10. Power meter shall be able to be stored in (-20 to +70) degrees C.
- a. Operating temperature shall be (-20 to +70) degrees C.
- D. Ground Fault Relays – 1200 Amperes and Below
- 1. Ground fault relays shall be Eaton GFR or approved equal. The ground fault relay protection system shall consist of a ground fault relay, a ground fault sensor and an associated disconnect device with shunt trip suitable for UL Class 1 Ground Fault Sensing and Relaying application. Ground fault relays, sensors and test panels components shall be UL listed for Class 1 application

2. Ground fault relay shall include a memory response which integrates intermittent faults with time using a 7-second time constant to protect against intermittent striking and restriking of arcing ground faults. Ground fault relay shall include a Trip Indicator light
 3. The ground fault relay shall have adjustable ground current pickup level available in three adjustment ranges 100 – 1200 amperes and adjustable time delay Inst., 10, 15, 25, 35, 45 and 60 cycles. Adjusting knobs shall be provided for making the settings which are capable of being locked in position after settings are made
 4. The ground fault relay and test panel shall be suitable for operating on a 120 Vac, 50/60.
 5. The ground fault relay output contacts shall be UL heavy-duty pilot type with 6A-120 VAC@ 60 HZ. SENSORS shall be suitable for system voltages of up to 600 volts at 60 Hz. Sensors shall have a primary withstand amperage of 200 kA for 0.05 seconds, 50 kA for 0.3 seconds and 4 kA continuous. Sensors shall be available either with solid core circular type or rectangular with removable link.
 6. Provide a test panel capable of testing the Ground Fault system with tripping the associated disconnect device or without tripping the associated disconnect device. The test panel shall also include as a minimum indicating lights “Ground Fault Trip”, “Control Power”, “System Resetting” and a reset pushbutton.
 7. The Arc Flash current limiting breaker shall be installed with a shunt trip relay.
 8. Control Power Transformer (CPT): A 480-120 V CPT shall be supplied and shall be one standard size larger than the total load requirement.
- E. Low-Voltage Surge Protective Equipment
1. Provide secondary surge protective equipment in the service entrance and where indicated on the Drawings. Provide components for all surge protective equipment covered by this Specification, designed and tested in accordance with UL 1449, NEMA LA-1, IEEE C62.41.1, IEEE C62.41.2 and IEEE C62.45.
 2. Surge capacitor, if used, shall be impregnated with non-PCB biodegradable dielectric fluid. Include an integral discharge resistor, which shall drain the residual voltage to 50 volts crest in less than 5 minutes after the unit has been disconnected from the circuit.
- F. Buses
1. Power busses shall be tin-plated copper.

PART 3 - EXECUTION

A. General

1. Install materials and equipment in a workmanlike manner utilizing craftsmen skilled in the particular trade. Installations shall have a neat and finished appearance. Carry out Work in accordance with NECA National Electrical Installation Standards unless specified otherwise.

2. Follow manufacturers' installation instructions explicitly. Wherever any conflict arises between the manufacturers' instructions, codes and regulations, and the Contract Documents, resolve the conflict and obtain acceptance by the DISTRICT. Keep copy of manufacturers' installation instructions on the jobsite available for reference at all times.

B. Removal or Relocation of Materials and Equipment

1. Where existing materials and equipment are removed, or relocated, remove all materials no longer used such as studs, straps, conduits, and wires (entire length). Remove or cut off concealed and embedded conduit, boxes, and other materials and equipment to a point at least 3/4 inch below the final finished surface and capped.
2. Repair affected surfaces to conform to the type, quality, and finish of the surrounding surface in a neat and workmanlike manner.

C. Setting Trip Units

1. Utilize the trip setting information required in Specification 16080 to set all adjustable trip units.

END OF SECTION

SECTION 16480

LOW-VOLTAGE MOTOR CONTROL

PART 1 – GENERAL

A. The Requirement

1. The Contractor shall furnish and install low-voltage motor control centers (MCCs) in accordance with the requirements of the Contract Documents.
2. Contractor shall confirm dimensions in the field as well as contract documents for Motor Control Center sections and the ATS.

B. Related Work Specified Elsewhere

1. The requirements of the following sections and divisions apply to the Work of this section. Other sections and division of the Specifications, not referenced below, shall also apply to the extent required for proper performance of this Work.

Section 01640 - Seismic Design of Equipment and Equipment Anchorage

Section 16010 - Electrical General Provisions

Section 16050 - Basic Materials and Methods

Section 16075 - Electrical Identification Nameplates and Warning Signs

Section 16080 - Electrical Testing

Division 16, Electrical, other applicable sections

C. Reference Specifications, Codes, and Standards

1. All Work specified herein shall conform to or exceed the applicable requirements of the referenced portions of the following publications to the extent that the provisions thereof are not in conflict with other provisions of these Specifications.

2. Comply with the applicable editions of the following codes, regulations, and Standards.

a. Codes and Regulations:

29 CFR 1910 Code of Federal Regulations, Title 29, Part 1910, U.S. Occupational Safety and Health Standards (OSHA)

CCR California Code of Regulations, Title 8, Div. 1, Chap. 4, Subchap. 5, Electrical Safety Orders

CCR California Code of Regulations, Title 24, Part 2, California Building Code (CBC)

CCR California Code of Regulations, Title 24, Part 3, California Electrical Code

NFPA 70 National Electrical Code (NEC)

- b. Industry Standards:
 - NEMA ICS 1 Industrial Control and Systems: General Requirements
 - NEMA ICS 2 Industrial Control and Systems Controllers, Contactors and Overload Relays Rated 600 Volts
 - NEMA ICS 18 Motor Control Centers
 - UL 508 Industrial Control Equipment
 - UL 845 Motor Control Centers
 - UL 1449 Surge Protective Devices
- c. Other Standards:
 - ANSI American National Standards Institute
 - NEMA National Electrical Manufacturers Association
 - UL Underwriters Laboratories
- 3. Comply with the applicable reference Specifications as directed in the General Provisions, and the Special Provisions.

D. Contractor Submittals

- 1. Submittals shall be in accordance with Section 01330, the General Provisions, the Special Provisions, and as specified herein.
- 2. Submittals shall include the following:
 - a. Complete enclosure drawings showing:
 - (1) Arrangement
 - (2) Dimensional plan and elevation, front view, shipping sections, and other elevation views, if pertinent
 - (3) Conduit entrance locations and dimensions for both top and bottom entrance
 - (4) Terminal block locations
 - (5) Anchor bolt locations and anchorage calculations
 - (6) Grounding connections
 - (7) Weight of equipment
 - b. Elementary Diagrams
 - (1) Elementary (schematic) wiring diagrams shall be furnished for each different control scheme.
 - (2) Each elementary diagram shall show all control devices, control power transformer (CPT) size, CPT fuse size, and device contacts, each of which shall be labeled.
 - (3) All wiring within each unit

- (4) All interconnecting wiring between units and between MCC, external equipment, and devices
- (5) Identification of all terminals, terminal blocks, and wires
- (6) Diagrams shall include specific equipment tags and I/O tags as indicated in Contract Documents.
- c. Bill of Material
- d. Spare Parts Lists
 - (1) List of priced spare parts, which are recommended by the manufacturer, during plant start-up and the first year's operation.
- e. Installation, Operating, and Maintenance Instructions
 - (1) Field storage, installation, operating, and maintenance instructions shall cover all the components furnished.
 - (2) One set of Installation, Operating, and Maintenance Instructions shall be shipped with the equipment.
- f. Protective device time-current characteristics
- g. Shop inspection procedures, witnessed Factory Demonstration Test (FDT) procedures, and Certified Test Reports

E. Quality Assurance

1. General:

Comply with the requirements specified herein and the applicable reference Specifications of the General Provisions and the Special Provisions.

Submittal Review Meetings: Contractor shall arrange a minimum of two submittal review meetings with the DISTRICT and the factory engineer. The first meeting shall be held before the design of the MCCs. The second meeting shall be held after the Contractor has received the DISTRICT's review comments of the first submittal.

Electrical and Mechanical Testing: All components shall be factory-tested in accordance with the applicable NEMA ICS and UL requirements.

The MCCs shall be subject to shop inspection and witnessed FDT by the DISTRICT at the MCC factory.

Field Testing: Field tests shall be performed in accordance with Specification section 16080 - Electrical Testing. In addition, tests shall include Operational Readiness Tests (ORTs), Functional Acceptance Test (FAT), and Reliability Acceptance Test (RAT).

2. Manufacturer's Qualifications:

Comply with the requirements for the certifications, licenses, training, skills, experience, and other qualifications specified in Part 3 of this Specification.

3. Contractor's Qualifications:

Comply with the requirements for the certifications, licenses, training, skills, experience, and other qualifications specified in Part 3 of this Specification.

PART 2 - PRODUCTS

A. Motor Control, General

1. The MCCs shall be UL-listed and bear UL labels.
2. The MCCs shall be suitable for application on a 3-phase, 60-hertz, solidly grounded or high-resistance grounded neutral system with a nominal system voltage of 480V ac and a design voltage of 600V ac.
3. The NEMA classification of the MCC is based on the area location designation in accordance with SECTION 16010 and have a SCCR rating of 65 kA.

B. Motor Control Centers

1. Manufacturers of the MCCs shall be Rockwell Automation (Allen Bradley) as Allen Bradley is the DISTRICT standard for MCCs.
 - a. Allen Bradley "Arc Resistant" product line
 - b. Allen Bradley "Secure Connect" product line
2. Each assembly shall consist of metal-enclosed, free-standing, dead-front, vertical, steel structures containing power buses, ground bus, combination magnetic motor starters, combination lighting controller, heating controllers, feeder breakers, metering, control equipment, and other devices as specified in the Contract Documents.
3. MCCs shall be designed to withstand fault currents of not less than the RMS symmetrical current as specified in the Contract Documents
4. Each MCC section shall be 90 inches high, 20 inches wide, 15 or 20 inches deep for front-of-board unit arrangement. Full depth horizontal wireways at top and bottom shall be provided. Vertical wireways shall be provided as applicable. MCCs shall be suitable for back-to-wall or back-to-back installation. When installed back-to-back, MCCs shall be completely independent assemblies, not sharing structural components or busing. Rear access shall not be required for inspection or maintenance. MCCs shall have NEMA Type 12 gasketed enclosures or per plans.
5. MCCs shall be provided with front-accessible main lug compartments for connection of incoming cables in the top or bottom section as indicated in the Contract Documents.
6. MCCs shall be designed so that either end of the lineup can be extended.

7. MCC individual compartments shall be separated by steel barriers for each VFD, starter, feeder, or other unit and be capable of being wired from front without unit removal.
 - a. Unit Construction
 - (1) Drawout units shall be provided with plug-on connections for each electrical power phase. Contact fingers shall be free-floating and self-aligning with tin-plated contacts for a low-resistance connection. Stabs shall be backed by spring clips to maintain a high-pressure connection to the vertical bus.
 - (2) Disconnect operators shall have external operator handles for circuit breakers. Handles shall be designed with up-down motion and with the down position being the OFF position. The operator handle shall be lockable in the OFF position with three 3/8-inch shank padlocks. Each operating handle shall indicate ON, OFF, and TRIPPED positions of the breaker.
 - (3) Unit doors shall be securely mounted with rugged, concealed-type hinges which allow the doors to swing open a minimum of 115 degrees. Doors shall be fastened to the MCC structure so that they remain in place when the unit is removed. Doors shall be secured with quarter-turn indicating-type fasteners.
 - (4) The operator handle shall be interlocked with the unit door so the disconnect cannot be switched ON unless the unit door is closed. A defeater mechanism shall be provided to allow the door to be opened when the unit is energized.
 - (5) When additional devices (e.g., relays, switches, pushbuttons, indicator lights) are added to a standard manufacturer's Size 1 or Size 2 MCC bucket, the bucket height shall be increased from 12 inches to 18 inches, as a minimum.
 - b. Cable Entrance
 - (1) Main circuits shall enter as shown. Control and feeder circuits shall enter from top and bottom.
 - c. Busway Entrance
 - (1) Pull box with flanged connection shall be provided for incoming busway. Bus connection to MCC main power bus and cable connection to ground bus shall match dimensions of incoming busway.
 - d. Buses
 - (1) Power buses shall be tin-plated copper.
 - (2) The horizontal power bus shall have a minimum rating as indicated in the Contract Documents. Horizontal power bus bars shall be fully supported, braced and isolated. Protective barriers shall be provided to prevent accidental contact with the bus with front cover open. Horizontal power bus shall allow for future extension at both ends. Long barrel, heavy duty, compression crimp type solderless lugs shall be supplied for each incoming line cable.
 - (3) Vertical power bus bars shall be fully supported, braced and isolated so that the bus will only be exposed where the drawout unit stab-on assembly makes contact. Automatic shutters shall be provided to cover these bus stab

openings when the units are withdrawn. Vertical power bus shall be rated 300A minimum.

- (4) For 4 wire system, neutral bus shall be 100 percent rated tin-plated copper.
- (5) A ground bus shall be provided running the full length of the MCC at the bottom of the lineup. The ground bus shall be drilled and supplied with heavy duty, long barrel, crimp lugs suitable for a 2/0 AWG copper ground gird conductor at each end of the MCC. Supply additional heavy duty, long barrel, crimp type ground lug for termination of the incoming circuit ground conductor. Ground Bus shall be tin-plated copper, rated 300A minimum.

8. Control Power Transformer (CPT)

- a. A 480-120V CPT shall be supplied for each magnetic motor starter, lighting controller, or heating controller, and shall be one standard size larger than the total starter load requirement including the motor space heater, control devices, and/or indicating lights shown in the Contract Documents.
- b. Each CPT shall have both primary legs fused, one secondary leg fused, and the other secondary leg grounded. Connections to both secondary legs shall be provided at the control terminal strip.

9. Motor Starter Units

- a. Motor starters shall be of the combination circuit breaker, magnetic contactor-type, 3-pole, and minimum NEMA Size 1 contactor size. The magnetic contactor shall operate with a coil voltage of 120V, 60 Hz, single-phase, except for size 5 and size 6 starters shall be 480V, 60 Hz.
- b. Each motor starter shall have a three-phase adjustable electronic overload relay with manual reset from a door-mounted pushbutton. Each overload relay shall have a normally open contact for alarm and a normally closed contact to trip the starter coil. Additional contacts shall be supplied as shown in the Contract Documents. Overload relay setting shall be based on actual motor nameplate full-load current.
- c. Each motor starter shall include a minimum of four auxiliary contacts, two normally open and two normally closed, for the DISTRICT's use in addition to those required to fulfill the intent of the control scheme specified in the Contract Documents. All spare auxiliary contacts shall be wired to the terminal blocks in the respective unit compartment.
- d. Combination motor starters and controller units shall be of the drawout type for NEMA Sizes 1 through 4. NEMA Size 5 starters may be of the bolted-on type, although drawout type shall be preferred. Drawout units of the same NEMA size shall be interchangeable with each other.
- e. Motor starter unit smaller than 12 inches high shall not be acceptable.
- f. Units shall be equipped with pilot devices such as START-STOP buttons, selector switches, and indicating lights as shown in the Contract Documents. Pilot devices shall be heavy-duty oil-tight type. Pilot lights shall be in accordance with Section 16050 requirements. Each pilot device shall be labeled with an engraved nameplate to show the function description (Local-Remote, Start, Stop, etc.) and the Loop Tag No. as assigned by the P&IDs. Refer to Specification section 16075 - Electrical Identification Nameplates and Warning Signs, for nameplate requirements.

- g. When VFDs, SMCs, or Power Monitor equipment is incorporated into the design of the MCC line up, MCC shall have factory installed industrial Ethernet cabling to allow Ethernet/IP communication to each device.
- h. When VFDs, SMCs, or Power Monitor equipment is incorporated into the design of the MCC line up, MCC shall include an Industrial Ethernet Switch (design should determine if a managed or unmanaged switch is required).
- i. Active Harmonic Filters limit harmonic current, and shall be incorporated in the MCC line up when VFDs are used and determined to be necessary per design (small VFD loads might not require a filter).

10 Circuit Breakers

- a. Circuit breakers shall be 3-pole, 600-volt ac, 100-ampere minimum frame size. All circuit breakers shall be manually operated with quick-made, quick-break, trip-free mechanisms of the toggle type with indication showing the ON, OFF, and TRIPPED positions. The breakers shall be equipped with suitable arc quenching devices. Main current carrying contacts shall be silver-plated and capable of carrying their rated current without exceeding the UL's specified temperature rise.
- b. Motor circuit protectors (MCPs) for motor starters shall be molded case type and have adjustable magnetic-only trip units.
- c. Main breakers shall be molded case type and equipped with solid-state trip units for adjustment of long time and short time trip functions for coordination with the feeder breakers. The instantaneous trip function, if equipped, shall be disabled.
- d. Feeder breakers shall be molded-case type with thermal-magnetic trip units.
- e. Circuit breakers shall be rated for operation in an ambient temperature of 40 degrees C. Circuit breakers shall be provided with correctly sized tin-plated Al/Cu rated mechanical Allen-head-screw type removable connector lugs.
- f. Feeder circuit breakers through 250-ampere frame size shall be of the drawout type. Frames larger than the 250-ampere frame size may be of the bolted-on type. Drawout units of the same frame size shall be interchangeable with each other.
- g. Circuit Breakers shall be suitable for use with 75-degree C wire at full NEC 75-degree C ampacity. Provide special features such as 100 percent rated breaker, shunt trip coil, solid state trips, etc. as shown.

11. Control Wiring and Terminal Blocks

- a. All internal control wiring shall be installed with flexible, stranded copper conductors, 14 AWG minimum size, with type TBS or SIS (cross-linked thermosetting polyethylene) insulation. All wiring shall be bundled and supported by plastic strip lock straps in a neat and workmanlike manner. Attach wire bundle anchors to buckets by mechanical means or with two parts epoxy glue. Adhesive "stick-on" type bundle supports shall not be acceptable.
- b. Terminal blocks shall be clearly labeled with machine-printed labels to identify connection points for field wiring.

- c. Control terminal blocks shall be pull-apart type on all drawout units for easy removal of the unit from the structure. Provide a minimum of 25 percent spare terminals.
 - d. Terminal blocks shall not be located inside the vertical wireway.
 - e. Each end of the internal wire shall be identified by a machine printed, white, shrink-on type sleeve marker (without heat shrinking), showing the wire number. Wire numbers shall match the manufacturer's connection diagrams. All wires originating from the same electrical node or point shall carry the same wire number.
 - f. When practical, all screw-type wire terminations shall use compression-type locking-spade connectors which firmly grip on the conductors and employ insulated compression sleeves to grip the wire insulation. Connectors terminating on terminal blocks shall also be of the locking-spade type.
12. Reduced Voltage Solid-State Starters (RVSS aka SMC)
- a. The RVSS shall be solid-state type and provide smooth stepless acceleration and deceleration of the motor from start to full speed and from full speed to stop. Supply a bypass contactor to bypass the RVSS when the motor reaches full speed.
 - b. A circuit breaker shall be provided for overcurrent protection and main disconnect. The breaker shall be lockable in the "OFF" position. A CPT with fuse protection as specified herein shall provide control power to the entire unit. When motor space heaters are used, they shall be energized from the CPT in the starter.
 - c. The RVSS shall be equipped with a micro-processor type protection relay to control, monitor, and protect the motor. The relay shall also protect the motor when the starter is in bypass mode, if so equipped.
 - d. Controls shall permit selection for soft-start with selectable kickstart. Current limiting during starting shall be programmable from 50 to 600 percent of full load current and field adjustable, as required. Provide full voltage start with ramp time less than 0.25 second, dual ramp start, or a start profile designed per original equipment manufacturer (OEM) equipment requirements. Controls shall permit field selection among ramp to stop, coast to stop, or stop profile designed for use with equipment specified.
 - e. Provide an alphanumeric, backlit LCD display for controller setup, diagnostics, status, and monitoring. Provide a keypad for parameter adjustment.
 - f. Provide 120-volt ac, 2-ampere rated dry auxiliary contacts for the following output signals:
 - 1. Solid-state Controller Trouble
 - 2. Overload Trip
 - 3. Solid-state Controller On
 - 4. Solid-state Controller Off
 - 5. System Ready
 - g. Provide 120-volt ac wetting voltage/interface for input contact signals as listed below:
 - 1. Reset
 - 2. Lockout-Stop

3. Jog
4. Run Request
- h. Provide LCD display monitoring functions as follows:
 1. Three-phase current
 2. Three-phase voltage
 3. Power in kW
 4. Energy usage in kWh
 5. Power Factor
 6. Elapsed Time
- i. Provide alarms as follows:
 1. Pre-start line fault alarm
 2. Running line fault advising power loss
 3. Shorted or open load connection
 4. Pre-start power loss with phase indication
 5. Over temperature
 6. Fault alarm with phase problem indication
- j. Provide defeatable protection as follows:
 1. Underload
 2. Undervoltage
 3. Overload
 4. Overvoltage
 5. Voltage unbalance
 6. Excessive starts per hour
 7. Phase reversal
 8. Stall
 9. Jam
 10. When fault conditions are detected, the controller shall inhibit starting or shall shutdown, as programmed. Fault diagnostics shall be indicated in descriptive text on the LCD display. The exclusive use of fault codes shall be unacceptable. Provide a common trouble contact for remote alarm programmable for fault indication.
- k. Refer to the schematic diagrams for additional control, monitor, and alarm requirements for specific driven systems.
- l. Supply documentation showing the RVSS is designed in accordance with acceptable ANSI and NEMA standards. In addition, the unit shall be factory-tested in accordance with ANSI standards.

- m. Supply documentation showing the RVSS has been tested for noise immunity on both input and output power connections. Noise testing shall be performed in accordance with NEMA ICS 2.
 - n. Manufacturer of the RVSS shall be Allen Bradley as Allen Bradley is the DISTRICT standard for MCCs.
13. Variable Frequency Drives
- a. Variable frequency drives shall conform to the requirements of Section 16419, but be installed within the motor control center.
14. Power Monitors
- a. Power monitors shall be provided in accordance with Specification Section 16290 – Power Monitors.
 - b. The final MCC line-up incorporating power monitors shall be UL-listed and labeled by the assembler.
15. Surge Protective Devices (SPD)
- a. The SPD shall be supplied and installed in the MCC. The SPD shall be suitable for a 480 V, 65 kA, wye-connected, high-resistance grounded system. The SPD shall have an internal disconnect and status/alarm light(s), mounted on the front panel; and shall have a TROUBLE contact (form C) rated a minimum of 120 V ac and suitable for low current signal applications. Provide a circuit breaker upstream of the SPD for its disconnect and service purpose.
16. Spare Starters
- a. Spare starter size, elementary diagram, and device requirements shall be as shown on the Drawings.
17. Nameplates
- a. Nameplates shall be engraved with inscription as shown in the Contract Documents and in accordance with Specification section 16075 - Electrical Identification Nameplate and Warning Signs.
18. Painting
- a. Painting method shall be manufacturer’s standard. Color shall be ANSI 61, light gray.
- C. Retrofit of Existing Motor Control
- 1. The design and construction of the modifications to the existing MCCs, vertical sections, individual buckets and stand-alone motor control units shall match that of the existing MCC or control unit it modifies, respectively. This shall also include the equipment enclosure color and NEMA rating. The retrofit equipment (e.g., MCC buckets) shall be UL labeled.
 - 2. Unless otherwise specified on the Drawings, the short circuit and other electrical ratings of the equipment used for the retrofit shall match that of the existing MCCs.

3. Unless otherwise specified on the Drawings, the retrofit equipment and its individual components shall be by the same manufacturer to match the existing MCC. The individual retrofit components of the MCCs and units shall be new and shall be UL-listed. No refurbished equipment and components shall be acceptable.
4. Individual retrofit units design (e.g., internal layout) shall be acceptable to DISTRICT.

PART 3 - EXECUTION

A. General

1. Perform field Work in a workmanlike manner with craftsmen skilled in the particular trade and licensed by the State of California. Provide Work presenting a neat and finished appearance.

B. Shop Inspection and Factory Demonstration Test

1. The DISTRICT will inspect and witness Factory Demonstration Tests (FDT) of the MCCs at the manufacturer's factory for conformance with the Contract Documents. The Contractor shall provide the DISTRICT a minimum of a two-week advance notice before the inspection and FDT and submit a complete set of up-to-date shop drawings incorporating all the DISTRICT's comments and shop inspection and FDT procedures.
 - a. The tests shall consist of the following:
 - (1) Manufacturer's standard factory tests
 - (2) Functional tests of each installed unit, including components, control logic, interlocks and proper wiring. Reduce voltage starters (RVSSs) and Variable frequency drives (VFDs) shall be tested.
 - (3) Functional tests of protective relays, meters (by secondary current or primary current injection), and SPD.
2. Before the test, a meeting shall be held in the factory to review the FDT test procedures and determine that all the drawings and documents for the equipment are up-to-date.
3. After the test, a meeting shall be held in the factory to review the punchlist items and corrective actions.
4. The Contractor shall be responsible for FDT performance. If the equipment being inspected and/or tested is not ready on Contractor's specified date, or does not meet the test criteria, or does not meet the Contract requirements, re-inspection and/or retesting of the equipment may be required. The Contractor shall be responsible for the cost and schedule impacts, including the cost of transportation, labor, and accommodations of the engineer associated with re-inspection and/or re-witness the FDT. The DISTRICT's costs incurred for re-inspection and/or retesting will be assessed through a deductive Contract change order.

C. Installation

1. Install the equipment in accordance with manufacturer's recommendations and NEMA ICS 2. Secure equipment to meet seismic requirements.

MOULTON NIGUEL WATER DISTRICT

2. Provide a qualified, factory-trained representative to inspect installation, and commission of the RVSS(s) and VFD(s). At the end of commissioning, provide certification signed by this representative that the equipment has been properly installed, tested, and is ready for energization.
3. Retighten all bolted current-carrying bus connections per manufacturer’s recommendations.
4. Protect the MCCs from dust and condensation during storage, construction, and before the electrical room ventilation system is in operation. Contractor shall provide temporary heaters and temporary power to prevent condensation inside the MCCs.
5. Adjust the trip settings of all MCPs and overload relays per manufacturer’s recommendations. Determine motor full load current from motor nameplate following installation. Prepare a typed tabulation of motor name, horsepower, nameplate full load current, measured full load current, overload trip setting and breaker trip setting. Include a copy of the tabulation in the Vendor Equipment Manuals in accordance with the Specification section entitled “Vendor Equipment Manuals”.
6. After the equipment is installed, touch up any scratches, marks, etc., incurred during shipment or installation of equipment. If required by the DISTRICT because of undue amount of scratches, repaint the entire assembly at no additional cost to DISTRICT. Ensure all gaps and holes along the bottom of the MCC are sealed after installation to prevent dust and debris build-up.

D. Field Tests

1. Field tests shall be in accordance with Specification section 16080 - Electrical Testing. ORT, FAT, and RAT of the MCCs shall be in accordance with the test procedures and shall be acceptable to the DISTRICT.

E. Training

1. The Contractor shall conduct on-site training of DISTRICT personnel in the operation and maintenance of the MCCs in accordance with Specification Section 01820 - Training of DISTRICT Personnel.

END OF SECTION

SECTION 16491

AUTOMATIC TRANSFER SWITCH

PART 1 - GENERAL

A. The Requirement

1. The Contractor shall furnish all tools, equipment, material, supplies, and perform all labor required to install an automatic transfer switch (ATS) rated as indicated in the Contract Documents and specified herein.
2. The work includes removing the existing ATS and installing the new ATS in the new main switchboard. Contractor shall confirm dimensions in the field as well as Contract Documents for the ATS.

B. Related Work Specified Elsewhere

The requirements of the following sections and divisions apply to the work of this section. Other sections and divisions of the Specifications, not referenced below, shall also apply to the extent required for proper performance of this work.

1. Seismic Design of Equipment and Equipment Anchorage 01640
2. Electrical, other applicable sections Division 16

C. Reference Specifications, Codes and Standards

1. All work specified herein shall conform to or exceed the applicable requirements of the referenced portions of the following publications to the extent that the provisions thereof are not in conflict with other provisions of these Specifications.
2. Comply with the applicable editions of the following codes, regulations, and standards.
 - a. Codes and Regulations
 - CCR: California Code of Regulations, Title 8, Div. 1, Chap. 4, Subchap. 5, Electrical Safety Orders
 - CCR: California Code of Regulations, Title 24, Part 2, California Building Code (CBC)
 - CCR: California Code of Regulations, Title 24, Part 3, California Electrical Code
 - NFPA 70: National Electrical Code (NEC)
 - b. Industrial Standards
 - ISO 9001: Quality Management Systems - Requirements
 - NEMA ICS 10 Part 1: Electromechanical AC Transfer Switch Equipment
 - NFPA 110: Standard for Emergency and Standby Power Systems
 - UL 508A: Industrial Control Panels
 - UL 1008: Transfer Switch Equipment

c. Other Standards

NEMA National Electrical Manufacturers Association

UL: Underwriters Laboratories

Comply with the applicable reference Specifications as specified in the General Provisions and the Special Provisions.

D. Contractor Submittals

1. Submittals shall be in accordance with Section 01330, the General Provisions, the Special Provisions, and as specified herein.
2. Submittals shall include detailed information on the following:
 - a. Dimensioned Outline and Arrangement Drawings (submit to DISTRICT for review and acceptance before equipment fabrication)
 - (1) Plan and front view
 - (2) Equipment arrangement and arrangement of door-mounted devices
 - (3) Location and size of conduit entry (both top and bottom entry), power cable terminator positions and ground connections from as-built dimensions obtained at the pump station
 - (4) Clearances for service and removing of the ATS and equipment weight
 - b. Elementary Diagrams: Elementary diagrams shall show all control devices and system control logic.
 - c. Detailed Connection (Wiring) Diagrams
 - (1) Connection diagrams showing internal wiring and interconnecting wiring between ATS and external equipment.
 - (2) Identification of terminals, terminal numbers, and wire numbers.
 - d. Bill of Material: Complete Bills of Material with catalog data sheets and manuals for all equipment and devices comprising the ATS. Where catalog cuts and other brochures depicting product characteristics are supplied, annotate to show product to be used on this project.
 - e. List of Spare Parts: A complete list of recommended spare parts. Include item descriptions, recommended quantities, and unit costs. The recommended list shall be based on a maintenance plan where DISTRICT will remove and replace failed items to the lowest replaceable module/component level.
 - f. Certified Test Reports
 - g. Installation, Operation, and Maintenance Manuals

- h. Programming Guides and Manuals: If the ATS requires computer software or configuration, provide 4 copies of all programming guides/manuals. Flow charts and listings of software developed shall be submitted to the DISTRICT. Submit final flow charts and program listings no later than 6 weeks prior to factory testing of the system.
- i. Record Documents
 - (1) Drawings of ATS representing the as-built condition and software shall be submitted to DISTRICT before system acceptance.
 - (2) Test documentation shall be provided in a three-ring binder(s). The binder(s) shall be clearly marked on the outside front cover and spine with the words "Test Results", the project name, and the date of completion (month and year). Scanner tests shall be printed on 8-1/2-inch by 11-inch paper. When repairs and re-tests are performed, the problem found and corrective action taken shall be noted, and both the failed and passed test data shall be collected in the binder.
- j. Provide information specified in Part 3.E Service and Maintenance of this Specification.

E. Quality Assurance

- 1. General: Comply with the requirements specified herein and the applicable reference Specifications of the General Provisions and the Special Provisions.
- 2. Manufacturer Qualifications:
 - a. The ATS manufacturer shall have ISO 9001 certification.
 - b. The ATS manufacturer shall maintain, as part of a national network, service facilities within 250 miles of the equipment installation to provide start-up service, 24-hour/day emergency service calls, repair work, service contracts, maintenance, and troubleshooting training of customer personnel.
 - c. Provide the following information:
 - (1) Location where the ATS components are repaired
 - (2) Location(s) nearest Moulton Niguel Water DISTRICT (26161 Gordon Road, Laguna Hills, CA 92653), where spare parts are stocked
 - (3) Guaranteed turnaround time after receipt at the repair facility for the repair and return of the repaired part.
- 3. Comply with the requirements for the certifications, licenses, training, skills, experience, and other qualifications specified in Part 3.D Field Service and Commissioning of this Specification.
- 4. Contractor Qualifications: Comply with the requirements for the certifications, licenses, training, skills, experience, and other qualifications specified in Part 3.A General of this Specification.

F. Site Conditions

1. Operating conditions of the ATS shall be as follows:
 - a. Indoors
 - b. Humidity: 50 to 85 percent
 - c. Ambient Temperature: 33°F - 120°F (Min – Max)
 - d. Altitude: Sea level
 - e. System Voltage: 480V, 3-phase, 60 Hz, solidly grounded
 - f. Short Circuit Fault Withstand: 65,000A
 - g. Seismic: Per Specification section 01640 - Seismic Design of Equipment and Equipment Anchorage and as specified herein.

G. Warranty

1. See Section 16010.

PART 2 - PRODUCTS

A. Manufacturer

1. The ATS manufacturer shall be ASCO.

B. Automatic Transfer Switch

1. Provide a 3-pole ATS.
2. The ATS shall be electrically operated contactor type. Use of automatic and non-automatic circuit breakers shall not be acceptable.
3. The ATS shall be UL-listed and bear the UL label.
4. The ATS shall have a continuous current carrying rating as shown on the drawings with the switch installed in an enclosure and shall conform to NEMA temperature rise standards.
5. The ATS shall provide three-phase voltage sensing (adjustable from 70 to 98 percent of nominal) on the normal source. The ATS shall provide three-phase voltage sensing (adjustable from 70 to 98 percent of nominal) and frequency sensing (adjustable from 85 to 98 percent of nominal) on the standby source rotation sensing.
6. All relays shall be continuous duty industrial type.
7. Selectable load/sources top or bottom.
8. Inspection, service, and maintenance of the ATS shall be from the front only. Main and arcing contacts shall be visible without major disassembly of switch components for inspection and maintenance.

9. A manual handle shall be provided for maintenance purposes to control the switch and with the switch de-energized.
10. The unit shall be rated based on all classes of loads, i.e., resistive, tungsten, ballast and inductive loads. Switch rated 400 amperes or less shall be UL-listed for 100 percent tungsten current load.
11. If connections to the ATS are by cables, provide heavy duty, long barrel, solderless terminal lugs for cable termination.

C. System Operation Description

1. When the voltage of any phase of the normal source falls below 80 percent of nominal, the generator start contacts shall close after a 5-second delay (adjustable from 0 to 6 seconds) to start and run the generator.
2. When the standby source has reached a voltage value of 90 percent and frequency within 95 percent of nominal, the load shall be transferred to the standby source after a time delay of 1 seconds (adjustable from 0 to 60 seconds). If normal source returns before the end of 1-second time delay and voltage is at 90 percent nominal on all phases, transfer shall not occur (i.e. no commit to transfer).
3. After transfer and on restoration of normal source voltage on all phases to above 95 percent for 50 minutes (adjustable from 0 to 60 minutes), the ATS shall retransfer the load back to the normal source. If normal source fails again after retransfer sequence is initiated, the ATS shall not retransfer.
4. If the generator should fail while carrying the load and normal source is returned to 95 percent nominal, the ATS shall retransfer immediately. If the generator should fail while carrying the load and normal source is not available, the ATS shall not retransfer.
5. After retransfer, the ATS shall stop the generator after a 5-minute delay (adjustable from 0 to 60 minutes) for unloaded run.

D. Control Panel

1. The control panel shall include the follow:
 - a. 4-Line by 20-Character LCD Display: Display of voltage and frequency of both sources and rotation
 - b. Display of ATS Positions
 - (1) Provision for recall of last 16 recorded events
 - (2) Adjustments to all settings and functions described herein
 - c. Self-Diagnostic: Control switch to simulate a normal source failure
 - d. Keypad or Control Switches: Time adjustments shall have 1-second resolution

E. Enclosure

1. The ATS shall be installed in a free standing NEMA 1 enclosure. The dimensions of the enclosure shall not exceed those indicated in the Contract Documents.
2. The painting method shall be manufacturer's standard. Exterior color shall be ANSI 61, light grey.
3. Cable entry shall be from top and bottom.

F. Accessories

1. A generator exercise-timer shall be provided to start the generator and transfer the load (when selected) for exercise purposes. The exercise-timer may be defeated so that it never automatically exercises the generator. The timer shall be adjustable from 1 to 60 days and duration adjustment of 1 to 60 minutes. Unloaded run time and shutdown after exercise shall be as described above.
2. Status and alarm contacts shall be provided to signal the PLC. Contacts shall be Form C rated 2A at 120V ac with externally wetted 120VAC. The contacts shall include the following:
 - a. ATS ON GENERATOR position; ATS ON UTILITY position; Source available
3. Metering shall be provided as follows:
 - a. Three-phase digital voltmeter, 1-percent accuracy or better, to measure normal source voltage and standby source voltage
 - b. Digital frequency meter, 1-percent accuracy or better, to measure normal source and standby source frequency
 - c. Rotation

G. Nameplates

1. Nameplates shall be in accordance with Specification section 16075 - Electrical Identification Nameplate and Warning Signs.

PART 3 - EXECUTION

A. General

1. Perform work in a workmanlike manner with craftsmen skilled in the particular trade. Provide work presenting a neat and finished appearance.

B. Installation

1. Install equipment in strict accordance with submittal drawings and manufacturer's recommendations.
2. Seismic-secure the ATS in accordance with manufacturer's recommendations and Specification 16010.

C. Factory Tests

1. A complete functional test shall be performed on the ATS prior to shipping from the factory.

D. Field Service and Commissioning

1. Provide the services of an experienced and factory-trained field service engineer to inspect the installation, programming, and commission the ATS and provide training for DISTRICT personnel.

E. Service and Maintenance

1. Tools and Equipment: CONTRACTOR shall identify and supply special tools or special test equipment necessary to perform maintenance or repair tasks.
2. Provide manufacturer's field service support information including the following:
 - a. Name and telephone number of field service personnel (maximum 100 miles).
 - b. Field service labor rates and expenses.
 - c. Guaranteed response times to service requests.

END OF SECTION

SECTION 16500

LIGHTING

PART 1 - GENERAL

A. The Requirement

1. The Contractor shall furnish and install lighting fixtures, and accessories for all lighting systems, complete and operable, all in accordance with the requirements of the Contract Documents.

B. Lighting

1. General

- a. Fixtures shall include lamps, ballasts, poles, mounting hardware, reflectors, lenses, globes, etc. and shall be supplied as complete operating units.
- b. Lighting system installation shall meet the specified seismic requirements.

C. Related Work Specified Elsewhere

1. The requirements of the following sections and divisions apply to the work of this Section. Other sections and divisions of the Specifications, not referenced below, shall also apply to the extent required for proper performance of this work.
 - a. Seismic Design of Equipment and Equipment Anchorage: 01640
 - b. Electrical General Provisions: 16010
 - c. Basic Materials and Methods: 16050
 - d. Raceway Systems and Pull Boxes: 16130

D. Reference Specifications, Codes, and Standards

1. All work specified herein shall conform to or exceed the applicable requirements of the referenced portions of the following publications to the extent that the provisions thereof are not in conflict with other provisions of these Specifications.
2. Comply with the applicable editions of the following codes, regulations, and standards:
 - a. Codes and Regulations

29 CFR 1910	Code of Federal Regulations, Title 29, Part 1910, U.S. Occupational Safety and Health Standards (OSHA)
CCR	California Code of Regulations, Title 8, Div. 1, Chap. 4, Subchap. 5, Electrical Safety Orders
CCR	California Code of Regulations, Title 24, Part 2, California Building Code (CBC)
CCR	California Code of Regulations, Title 24, Part 3, California Electrical Code
NFPA 70	National Electrical Code (NEC)

- b. Industry Standards
 - ANSI C82.1 For Lamp Ballast - Line Frequency Fluorescent Lamp Ballast
 - ANSI C82.4 For Lamp Ballast - Ballasts for High-Intensity-Discharge and Low-Pressure Sodium Lamps (Multiple-Supply Type)
 - ANSI C82.11 High-Frequency Fluorescent Lamp Ballasts
 - IESNA RP-7 Lighting Industrial Facilities
 - UL 924 Emergency Lighting and Power Equipment
 - c. Other Standards
 - ANSI American National Standards Institute
 - ETL Intertek ETL SEMKO
 - IESNA Illuminating Engineering Society of North America
 - NEMA National Electrical Manufacturers Association
 - UL Underwriters Laboratories
3. Comply with the applicable reference Specifications as directed in the General Requirements and the Additional General Requirements.

E. Contractor Submittals

- 1. Submittals shall be in accordance with the General Requirements, the Additional Requirements, and as specified herein.
 - a. Catalog literature for each fixture specified including description of materials, type of diffuser, hardware, reflector, finish, mounting/support details, weight, electrical, photometric data, and ballast. The submittal shall also show evidence of UL listing or other testing laboratory acceptable to the Engineer.
 - b. If substitution fixtures are proposed, the submittal shall have sufficient information for complete comparison of the proposed fixture to the originally specified fixture. Photometric data shall include coefficients of utilization, average brightness, candlepower distribution curves, and lumen output chart.
 - c. Pole-mounted fixtures shall include complete data on the pole material, finish, handholes, anchoring, dimensions, structural loading data, and fixture attachment details.
 - d. Ballast catalog data shall include lamp wattage, ballast efficiency factor (BEF), input watts, sound rating, power factor, and type of ballast. Data for outdoor ballast shall include low-temperature starting characteristics.
 - e. Photocell submittal shall include voltage and wattage ratings, ambient light level switching control means, and enclosure rating.

F. Quality Assurance

1. General

- a. Comply with the requirements specified herein and the applicable reference Specifications of the General Requirements, and the Additional General Requirements.
- b. Exterior lighting system operation shall be demonstrated during the hours of darkness to indicate that fixtures are properly focused and aimed, photocell operation is correct, and that fixture switching functions as intended. Similar requirements shall apply to interior lighting. The Contractor shall also demonstrate that the light fixtures are properly circuited and the panel schedules and the panel directories are correctly documented.
- c. Lighting demonstration shall occur within 2 weeks prior to start of Reliability Acceptance Tests (RAT).
- d. Fixture Appearance
 - (1) Fixture lenses, diffusers, and reflectors shall be cleaned just prior to system demonstrations.
 - (2) Fixture trim, including poles and support brackets, where finish has been damaged, shall be refinished or replaced.

G. Site Conditions

1. Seismic requirements shall be in accordance with Section 01640, Seismic Design of Equipment and Equipment Anchorage, and this Section.

PART 2 - PRODUCTS

A. Lighting Systems General

1. Lighting system material shall be UL-listed or listed by an OSHA-recognized testing agency acceptable to the Engineer.
2. Lighting systems for occupied building spaces shall conform to IESNA requirements.

B. Luminaires

1. General: Provide luminaires, with proper hangers, pendants, canopies, lamps, etc., necessary for complete installation. Provide luminaires having "feed thru" or separate junction boxes. Provide two-lamp ballasts wherever possible. Provide luminaires with wire leads not smaller than 18 AWG and with all electrical components easily accessible and replaceable without removing the luminaire from the ceiling. Luminaires shall be LED.
2. Special Requirements
 - a. Provide pole and luminaire combinations capable of withstanding, without damage, the specified wind load and seismic load. Provide extruded aluminum poles of size, height, type, and finish shown in the Contract Documents. Pole base shall be reinforced concrete as indicated in the Contract Documents.

- b. Luminaires shall be rated for the locations where they are installed. Refer to Section 16010, Electrical General Provisions, for area designation. Luminaries installed in wet and corrosive locations shall have a removable prewired ballast.
- c. Where designated for emergency lighting service provide luminaires containing integral battery module, charger, and control module to illuminate one-half of the lamps in the luminaire to a value of approximately 40 percent output for 90 minutes in case of power failure. Furnish unit that automatically recharges the battery on return of normal line voltage.
- d. For exterior luminaires with photocells, provide the luminaire manufacturer's standard design. Adjust photocells to switch light ON at dusk and OFF at dawn.
- e. Provide pendant type luminaires with a safety cable attached to the structure and the luminaire at each support capable of supporting four times the vertical load.

C. Reflectors

- 1. Reflectors and reflecting cones or baffles shall be as follows:
 - a. Free of any tooling marks, indentations caused by riveting or other assembly techniques.
 - b. No rivets, springs, or other hardware visible after installation.
 - c. First quality polished, buffed, and anodized finish.
 - d. Low iridescence for fluorescent sources.
 - e. Finish color as indicated in the Contract Documents.
 - f. All reflectors and baffles of modified elliptical contour, with no apparent brightness from above 40 degrees above the nadir, with no lamp image or any part of the lamp visible from above 40 degrees above the nadir.
 - g. Cone flange formed as an integral part of the cone and with identical color and finish, unless specified otherwise. Width of the flange covers all ceiling opening without light leaks or hardware visible.

D. Lenses

- 1. All lenses shall be secured by positive means with neoprene or silicone gasket or washers, as required to hold the lens tight within a frame or attaching to the housing.
 - a. All glass lenses shall be heat treated (tempered) or sealed with a clear acrylic laminate layer to provide a "safety glass" rating. All lenses which require removal for relamping or normal maintenance shall be attached to the fixture housing by a minimal length of safety chain to prevent the lens from falling and striking surrounding surfaces. Glass edges exposed during the relamping process shall be gasketed to prevent chipping or cracking.
 - b. Acrylic lenses shall be 100 percent virgin acrylic polymer, colorless.

E. (Not Used)

F. Fixture Manufacturers

1. Fixture manufacturers shall be as called out in the fixture schedule shown on the Drawings, or equal.

G. Lamps

1. General: Provide lamps of the types and wattage indicated for each luminaire in the fixture schedule indicated in the Contract Documents.
2. Manufacturers: See Lighting Fixture Schedule included in Contract Drawings. Contractor shall use the manufacturers called out in the Contract Drawings or approved equal.

H. Lighting Control

1. General: Provide lighting control system as indicated in the Contract Documents. Lighting system shall have occupancy sensor controls. This shall be tested and adjusted per NA7.6.2.3 occupancy sensor acceptance. Outside lighting system shall have astronomical time-switch and photo control and this shall be tested and adjusted per NA7.8.2 outdoor lighting shutoff controls.
2. Photocells
 - a. Outdoor lighting shall be controlled by a photoelectric cell in accordance with the Contract Documents. The photocell shall be rated 120 V, 2000 W, 3-wire service, single-pole, single-throw (SPST).
 - b. The photocell shall be completely self-contained in NEMA 4 housing, ON at dusk and OFF at dawn; time delay feature to prevent false switching; and field adjustable to control operating levels. Photocell shall be Tork Model No. 2101, or equal.
3. Dimming Systems
 - a. Provide fluorescent dimmer capable of dimming from one to ten 40-watt rapid start lamps. Supply dimmer that fits in a single-gang wall box. Provide positive OFF switching and low-intensity trim adjustment without removing dimmer from box.
 - b. Fluorescent dimmer switches shall be all solid-state with built-in circuitry to compensate for line voltage dips and shall have an "ON-OFF" switch. The dimmer system shall be rated for operation with not less than 28-40 W rapid-start lamps at 120 V ac. Ballasts shall be coordinated with the dimming switches furnished. Dimmer switches shall be as manufactured by Hunt, Lutron, Seymour, or equal.
4. Motion Sensors
 - a. Provide motion sensors capable of turning off fluorescent lights completely with no flickering.
 - b. Motion sensors shall be as manufactured by Leviton, Bryant, or equal.

I. Emergency Lighting

1. Emergency lighting units shall be as specified on the fixture schedule. The two lighting heads shall consist of sealed beam lamps. The unit shall be able to accommodate additional remotely located fixtures when specified in the Contract Documents. Batteries shall be the

sealed nickel cadmium, maintenance-free type rated for a minimum of 90 minutes. An integral battery charger shall automatically provide a high-rate charge immediately upon restoration of normal power to the unit. When float voltage is reached, the charge level shall be maintained continuously. Time delay shall be provided to maintain emergency lighting for fifteen (15) minutes after normal power restoration. The fixtures shall be UL-listed, and shall be in accordance with UL 924.

J. Exit Signs

1. Exit signs shall be red, light-emitting diode (LED) type. LEDs shall be provided to illuminate the sign or letters from within and the background of the exit sign. They shall be designed to remain illuminated upon failure of the normal power supply via an internal nickel cadmium battery. An integral battery charger shall automatically provide a high-rate charge immediately upon restoration of normal power to the unit. When float voltage is reached, the charge level shall be maintained continuously. The number of faces, arrow signage, and enclosure type shall be as shown on the Drawings. The exit signs shall be Chloride Systems, Dual-Lite, Lithonia Lighting, or equal.

K. Hardware

1. Hardware for fixtures located outdoors, in wet and corrosive areas shall be Type 316 stainless steel. Lighting pole hardware including nuts, bolts and washers for anchoring shall be Type 316 stainless steel.

PART 3 - EXECUTION

A. Luminaires

1. General
 - a. Install each luminaire as recommended by the luminaire manufacturer, per National Electrical Code and California Electrical Code requirements and as shown on the Drawings.
 - b. Install luminaires plumb, level, straight, and true with reference to adjacent walls.
 - c. Where luminaires height is indicated on the Drawings, the height shall be as measured from the bottom of the luminaire to finished floor or finished grade, whichever is applicable.
 - d. After construction of total project is completed, clean luminaires and lenses. Replace all lamps used for lighting during construction.
 - e. Circuit directories in panelboard door pockets shall be typewritten to identify all circuits.
 - f. All flood and spotlights shall be aimed as shown on the Drawings.
 - g. Install all recessed luminaires tight with the finished surface so that no spill light shall show between the ceilings and the sealing rings, and furnish plaster frames when required by ceiling construction.
 - h. Provide each fluorescent recessed luminaire with two safety chains or two 12 AWG soft-annealed galvanized steel wire of length needed to secure luminaire to building structure independent of ceiling structure. Tensile strength of chain or wires and

fastening to structure shall be adequate to support weight of luminaire. Fasten a chain or wires to each end of luminaire.

- i. Coordinate luminaire locations with other utility systems (e.g., Plumbing, HVAC). Relocate luminaires to avoid conflict with these other systems and to avoid blockage of luminaire light output. Obtain Engineer's acceptance on the new locations.

B. Ballasts

1. Install ballasts in accordance with manufacturer's recommendations.

C. Lighting Control

1. Install lighting control as shown on Drawings.
2. Provide ballasts compatible with the dimming system.

D. Fixture Mounting

1. Surface-mounted and flush-mounted fixtures shall be solidly connected to a junction box. Suspended HID fixtures shall be hung utilizing pendant mounting or stainless steel chains and hooks. Each HID fixture, or row of fixtures, shall be electrically connected by a length of Type SO flexible cord, 3-conductor, 14 AWG minimum, with a twist-lock plug to a twist-lock receptacle mounted in an individual junction box. Plugs and receptacles shall be as manufactured by Hubbell, General Electric, or equal.

END OF SECTION

Section V

Standard Drawings

**TABLE OF CONTENTS
STANDARD DRAWINGS**

<u>Dwg No.</u>	<u>Dwg Title</u>
G-GN	General Construction Notes
G-1	Pipe Support
W-GN	General Potable Water Notes
W-1	Standard 3/4" & 1" Water Service
W-2	Standard Water Meter Manifold
W-3	Standard 1-1/2" & 2" Water Service
W-4	3", 4", 6", and 8" Standard Meter Commercial Continuous Flow Meter
W-5	3", 4", 6", and 8" Irrigation Meters
W-6	Hot Tap
W-7	Standard Fire Hydrant
W-8	Valve Assembly
W-9	Standard Combination Valve Assembly
W-10	Standard Temporary Plug and Blow-off Installation
W-11	Pipe Bedding
W-12	Typical Thrust Block
W-13	Steel Casing Pipe
W-14	Design Criteria for Separation of Recycled Water and Sewer Mains for New Potable Water Mains
W-15	Above Ground Private Fire Service
W-16	Conversion from Below Ground to Above Ground Private Fire Service
W-17	Backflow Prevention Assembly 2" and Smaller
W-18	Backflow Prevention Assembly 3" and Larger
W-19	Concrete Encasement and Slope Anchors
W-20	Guard Post Detail
W-21	Removable Post Detail
W-22	Hydrostatic Pressure Testing
W-23	Zinc Anode for Services and Air-Vacs
W-24	Above Ground and Buried Insulating Flange
W-25	Joint Bonding
W-26	Alumino-Thermic Weld
RW-GN	General Off-Site Recycled Water Notes
RW-1	Design Criteria for Separation of Potable Water and Sewer Mains for New Recycled Water Mains
S-GN	General Sewer Notes
S-1	Standard Manhole
S-2	Typical Concrete Base and Joint Details
S-3	Manhole Frame and Cover for 48" Manhole
S-4	36" Manhole Frame and Two Concentric Covers for 60" and 72" Manhole
S-5	PVC & VCP Pipe Bedding
S-6	Typical House Lateral
S-7	Typical Sewer Wye Connection
S-8	Concrete Encasement Type A, B & C

MOULTON NIGUEL WATER DISTRICT

S-9	Concrete Slope Anchors
S-10	Steel Casing Pipe
S-11	Design Criteria for Separation of Potable Water and Recycled Water Mains for New Sewer Mains
S-12	External Drop Manhole
S-13	Grease Interceptor Tank with Sample Box
S-14	Trash Enclosure

GENERAL CONSTRUCTION NOTES

1. THE CONTRACTOR SHALL BE IN POSSESSION OF TWO (2) COPIES OF APPROVED CONSTRUCTION PLANS PRIOR TO STARTING CONSTRUCTION, AND SHALL DEMONSTRATE PROOF OF THIS UPON REQUEST. A PRECONSTRUCTION CONFERENCE OF REPRESENTATIVES FROM AFFECTED AGENCIES AND THE CONTRACTOR SHALL BE HELD ON THE JOB SITE A MINIMUM OF 72 HOURS PRIOR TO START OF WORK.
2. THE CONTRACTOR SHALL NOTIFY THE DISTRICT INSPECTION SUPERVISOR AT THE MOULTON NIGUEL WATER DISTRICT AT (949) 425-3593 AT LEAST FIVE WORKING DAYS PRIOR TO CONSTRUCTION FOR INSPECTION.
3. THE FACILITY IMPROVEMENTS ARE TO BE INSTALLED BY THE APPLICANT. ALL WORK SHALL CONFORM TO THE DISTRICT'S "STANDARD SPECIFICATIONS FOR THE CONSTRUCTION OF POTABLE WATER, SEWER, AND RECYCLED WATER FACILITIES," AS LAST REVISED. THE CONTRACTOR SHALL HAVE A COPY OF THE PLANS AND APPLICABLE STANDARD SPECIFICATIONS ON THE JOB AT ALL TIMES.
4. THE CONTRACTOR SHALL NOTIFY UNDERGROUND SERVICE ALERT (USA) AT 811 A MINIMUM OF TWO WORKING DAYS PRIOR TO ANY EXCAVATION WORK.
5. ALL FACILITY CONNECTIONS, UTILITY CROSSINGS, AND PARALLEL UTILITIES THAT WOULD POTENTIALLY BE IMPACTED BY CONSTRUCTION ACTIVITIES SHALL BE POTHOLED AND FACILITY LOCATIONS AND ELEVATIONS VERIFIED PRIOR TO CONSTRUCTION. THE EXISTENCE AND LOCATION OF UNDERGROUND UTILITIES OR STRUCTURES SHOWN ON THESE PLANS SHOWN HEREON IS APPROXIMATE. IT IS THE RESPONSIBILITY OF THE CONTRACTOR TO VERIFY THE LOCATION OF UTILITIES IN THE FIELD TWO WEEKS PRIOR TO CONSTRUCTION AND COORDINATE ALL PHASES OF CONSTRUCTION WITH THE VARIOUS UTILITY COMPANIES INVOLVED. THE CONTRACTOR IS REQUIRED TO TAKE ALL DUE PRECAUTIONARY MEANS NECESSARY TO PROTECT THOSE UTILITY FACILITIES NOT SHOWN ON THESE PLANS. AS FIRST ITEM OF WORK, CONTRACTOR SHALL, BEFORE STARTING CONSTRUCTION:
 - 5.1. PROVIDE POTHOLE PLAN FOR REVIEW AND ACCEPTANCE PRIOR TO POTHOLING
 - 5.2. POTHOLE ENTIRE PROJECT EXTENTS INCLUDING:
 - 5.2.1. ALL POINTS OF CONNECTION
 - 5.2.2. ALL CROSSINGS
 - 5.2.3. ALL PARALLEL UTILITIES WITHIN 5- FEET OF NEW FACILITY (NOT LESS THAN ONE POTHOLE PER 25- FEET WHERE PARALLEL)
 - 5.3. SUBMIT POTHOLE REPORT SHOWING TOP, BOTTOM, AND WIDTH OF UTILITY
 - 5.4. BASED ON POTHOLING RESULTS, IDENTIFY ANY PORTIONS OF THE PROJECT THAT WILL REQUIRE RE-DESIGN.
 - 5.5. ALLOW 2 WEEKS FOR DISTRICT'S REVIEW AND APPROVAL INCLUDING REVIEW OF ANY REQUIRED RE-DESIGN.
6. THE CONTRACTOR SHALL PROTECT EXISTING UTILITIES IN PLACE, UNLESS OTHERWISE NOTED. THE CONTRACTOR SHALL BE RESPONSIBLE FOR THE EXPENSES ON ANY REPAIR OR APPROVED RELOCATION TO SAID FACILITIES. ANY RELOCATIONS OF EXISTING FACILITIES ARE SUBJECT TO APPROVAL BY DISTRICT STAFF.
7. CONSTRUCTION WATER MAY BE TAKEN ONLY AT LOCATIONS APPROVED BY MNWD. RECYCLED WATER, WHERE AVAILABLE, SHALL BE USED FOR ALL BACKFILL, COMPACTION, AND CONSTRUCTION WATER REQUIREMENTS. A CONSTRUCTION METER AND VALVE SHALL BE INSTALLED AT A LOCATION ESTABLISHED BY MNWD. CONTRACTOR WILL BE PROVIDED WITH A 2 ½" OUTLET. CONTRACTOR WILL BE REQUIRED TO TRANSPORT WATER TO THE CONSTRUCTION SITE FOR USE AS NEEDED. CONTRACTOR SHALL CHECK-OUT A WATER METER FROM THE DISTRICT'S MAIN OFFICE (DEPOSIT REQUIRED) FOR TRACKING PURPOSES. ALL DISTRICT WATER USED ON-SITE SHALL BE PROPERLY METERED WITH A METER OBTAINED FROM THE DISTRICT. THE USE OF JUMPERS IS NOT ALLOWED. METERS MUST BE INSTALLED PRIOR TO OCCUPANCY OF A DWELLING.
8. AN ENCROACHMENT PERMIT FROM THE COUNTY OR CITY HAVING JURISDICTION IS REQUIRED PRIOR TO ANY WORK WITHIN PUBLIC RIGHT_OF_WAY OR EASEMENT.
9. TRAFFIC CONTROL SHALL BE THE CONTRACTOR'S RESPONSIBILITY. CONTRACTOR SHALL SUBMIT PROPOSED TRAFFIC CONTROL PLANS TO THE CITY FOR REVIEW AND APPROVAL PRIOR TO OBTAINING AN ENCROACHMENT PERMIT AND COMMENCING WORK.
10. NO FACILITY IS TO BE BACKFILLED UNTIL INSPECTED BY THE DISTRICT.
11. THE CONTRACTOR IS RESPONSIBLE FOR MAINTAINING A 1' MINIMUM VERTICAL CLEARANCE FROM EXISTING UTILITIES AND SHALL FOLLOW MINIMUM SEPARATION REQUIREMENTS FROM THE CALIFORNIA DEPARTMENT OF PUBLIC HEALTH (WHICHEVER IS MORE STRINGENT), AS DEPICTED ON MNWD STANDARD DRAWINGS W-14 FOR NEW POTABLE WATER MAINS, S-11 FOR NEW SEWER MAINS, AND RW-1 FOR NEW RECYCLED WATER MAINS.
12. TRENCH BACKFILL FROM THE BOTTOM OF THE TRENCH TO THE AGGREGATE BASE SHALL BE COMPACTED TO NOT LESS THAN 90% RELATIVE DENSITY, AND THE AGGREGATE BASE AND THE TOP 6-INCH OF THE BACKFILL MATERIAL SHALL BE COMPACTED TO 95% RELATIVE DENSITY.
13. TUNNELING OF CURBS, GUTTER SIDEWALKS, CROSS-GUTTERS, AND OTHER STRUCTURES WHERE AN AIR VOID MAY BE CREATED WILL NOT BE PERMITTED. JACKING, PUSHING, AND BORING ARE ACCEPTABLE. CONCRETE REPLACEMENT SHALL BE TO THE NEAREST CONSTRUCTION JOINT.
14. UPON COMPLETION OF THE WORK, THE CONTRACTOR IS TO PROVIDE MNWD AND THE DEVELOPERS/APPLICANTS ENGINEER WITH AN AS-BUILT SET OF JOB PRINTS WITH TIE-DOWN MEASUREMENTS FOR ALL FACILITY ASSETS AND APPURTENANCES.
15. RECORD DRAWINGS SHALL BE SUBMITTED BY THE DEVELOPERS/APPLICANTS ENGINEER TO THE DISTRICT FOR REVIEW AND APPROVAL AT THE CONCLUSION OF CONSTRUCTION ACTIVITIES, AND WILL REFLECT ANY FIELD CHANGES AND INSPECTORS/CONTRACTORS FIELD NOTES.

MOULTON NIGUEL WATER DISTRICT

GENERAL CONSTRUCTION NOTES

G-GN
AUGUST 2024

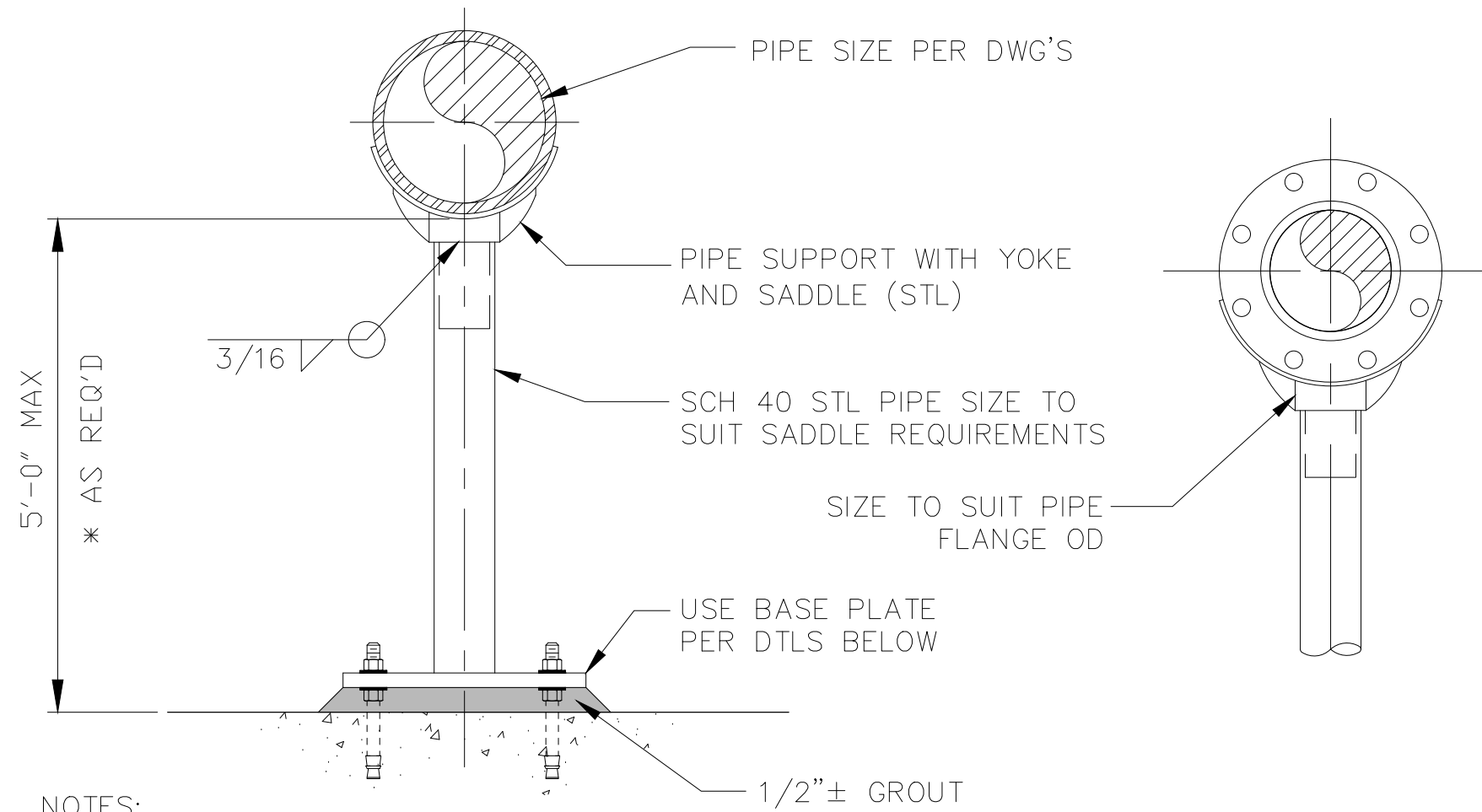

NOTES:

1. HDG AFTER FABRICATION

PIPE SIZE (INCH)	SCH 40 STL PIPE SIZE (INCH)	ANCHOR BOLT (INCH)
4	3	1/2
6	3	1/2
8	3	3/4
10	3	3/4
12	3	3/4

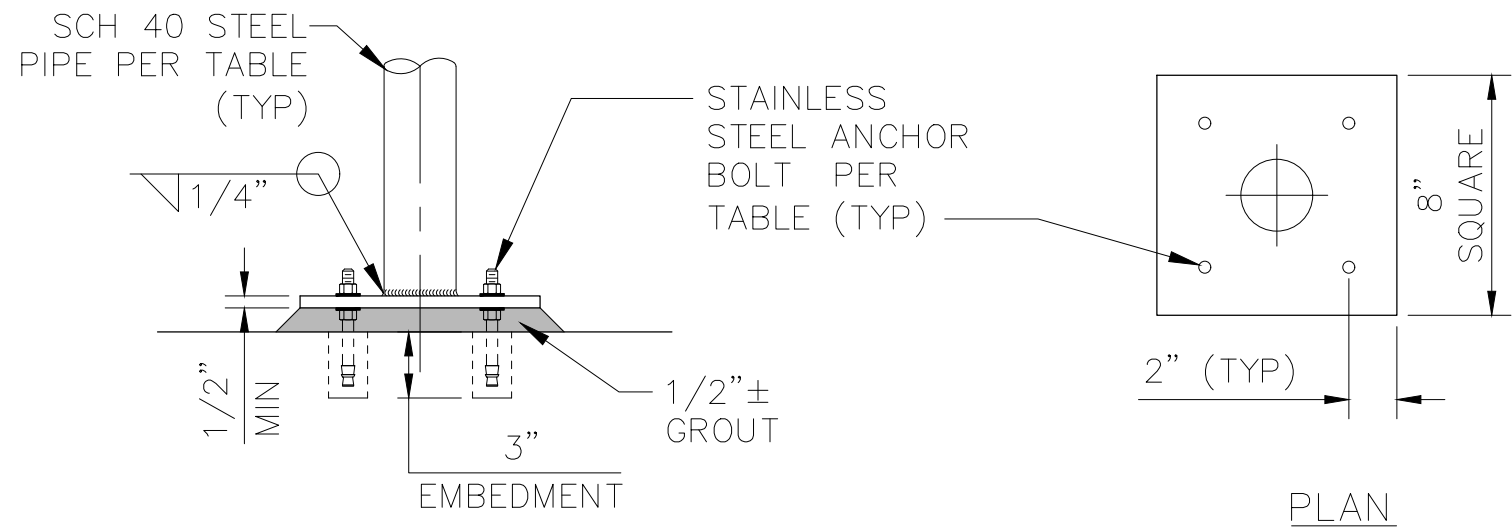

ELEVATION

PLAN

GENERAL POTABLE WATER NOTES

1. ALL MNWD GENERAL CONSTRUCTION NOTES SHALL APPLY (PER MNWD STANDARD DRAWING G-GN).
2. WATER SERVICE MUST BE MAINTAINED TO ALL CUSTOMERS WITHIN THE CONSTRUCTION AREA AT ALL TIMES. IF THE PRIMARY SOURCE OF WATER IS INTERRUPTED, A TEMPORARY SECONDARY SOURCE SHALL BE SUPPLIED BY THE CONTRACTOR AND APPROVED BY THE MOULTON NIGUEL WATER DISTRICT. ANY EXPENDITURES INCIDENTAL THERE TO SHALL BE BORNE BY THE CONTRACTOR.
3. POTABLE WATER MAINS SHALL BE INSTALLED AFTER THE INSTALLATION OF CURB AND GUTTER AT SIX FEET OFF OF CURB FACE UNLESS SHOWN OTHERWISE ON PLANS, OR AS STAKED BY THE APPLICANT'S SURVEYOR AT A MINIMUM 50-FOOT STATIONING IF NOT WITHIN A ROADWAY.
4. NEW POTABLE WATER PIPE 12" AND SMALLER SHALL BE INSTALLED WITH A MINIMUM COVER OF 42" BELOW FINISHED SURFACE OR AS SHOWN ON PLANS (WHICHEVER IS GREATER). NEW POTABLE WATER PIPE GREATER THAN 12" SHALL BE INSTALLED WITH A MINIMUM COVER OF 48" BELOW FINISHED SURFACE OR AS SHOWN ON PLANS (WHICHEVER IS GREATER).
5. SHUT DOWN OF EXISTING POTABLE WATER MAINS SHALL BE SCHEDULED WITH AND PERFORMED BY THE DISTRICT. SCHEDULED SHUTDOWN SHALL BE REQUESTED AT LEAST 5 WORKING DAYS PRIOR TO REQUESTED OUTAGE TO THE DISTRICT.
6. DEWATERING OF THE WATER MAIN IS TO BE COORDINATED WITH MNWD STAFF. CONTRACTOR SHALL PUMP WATER INTO WATER TRUCK AND DISCHARGE INTO SEWER MANHOLE IN THE PRESENCE OF THE DISTRICT INSPECTOR.
7. ALL VALVES SHALL BE LOCATED OFF THE TEE UNLESS OTHERWISE APPROVED BY THE DISTRICT. AT INTERSECTIONS AND BUS STOPS WITH CONCRETE PADS, THE MAIN LINE SHALL BE ROPED TO AVOID CROSS GUTTER CONFLICT.
8. ALL NUTS AND BOLTS, INCLUDING VALVES, SHALL BE GRADE 316 STAINLESS STEEL. ALL BURIED FLANGES, VALVES AND FITTINGS SHALL BE WRAPPED WITH 10-MIL POLYETHYLENE SHEET.
9. THE CONTRACTOR SHALL BE RESPONSIBLE FOR BRINGING VALVE CANS TO GRADE AFTER FINAL PAVEMENT IS PLACED.
10. ACP SHALL BE REMOVED, HANDLED, AND DISPOSED OF IN A MANNER THAT KEEPS THE MATERIAL IN A NON-FRIABLE CONDITION. CONTRACTOR SHALL BE RESPONSIBLE FOR DISPOSAL OF ALL ACP REMOVED DURING CONSTRUCTION. CONTRACTOR SHALL FOLLOW ALL STATE AND FEDERAL REGULATIONS PERTAINING TO THE PROPER HANDLING, REMOVAL, AND DISPOSAL OF ACP AND SHALL BEAR ANY EXPENSES FOR HANDLING, REMOVAL, DISPOSAL, AND REMEDIAL CLEANUP ACTIVITIES. CONTRACTOR SHALL PROVIDE MNWD WITH THE MANIFEST PROPER ACP DISPOSAL.
11. NO TAPS OR OTHER CONNECTIONS SHALL BE MADE TO EXISTING DISTRICT WATER MAINS PRIOR TO CONDUCTING AN APPROVED PRESSURE AND BACTERIOLOGICAL TEST ON THE NEW WATER DISTRIBUTION SYSTEM. TAPPING SLEEVES SHALL BE PRESSURE TESTED IN AN APPROVED MANNER IN THE FIELD IN THE PRESENCE OF THE DISTRICT INSPECTOR, PRIOR TO TAPPING THE MAIN LINE. TAPPING OF THE MAIN LINE SHALL NOT PROCEED UNLESS A DISTRICT INSPECTOR IS PRESENT.
12. ALL WATER MAINS SHALL BE REQUIRED TO PASS PRESSURE, LEAKAGE, AND BACTERIOLOGICAL TESTS PER SECTION 15042 OF THE STANDARD SPECIFICATIONS OF THE MOULTON NIGUEL WATER DISTRICT PRIOR TO ACCEPTANCE. A TEMPORARY CONNECTION WILL BE REQUIRED TO FACILITATE THIS TESTING. DISINFECTING OF ALL WATER MAINS SHALL BE PER MNWD SPECIFICATION 15041. ALL WATERLINE TIE-INS SHALL BE MADE IN THE PRESENCE OF AN AUTHORIZED DISTRICT INSPECTOR. ALL CONNECTING PARTS SHALL BE SWABBED WITH A 5% CHLORINE SOLUTION (NSF APPROVED). POTABLE WATER SHALL BE USED TO FILL, PRESSURE TEST, AND DISINFECT WATER MAIN. ALL FLUSHING WATER SHALL BE CONVEYED TO SEWER MANHOLE AN AIR GAP WILL BE REQUIRED, THIS SHALL BE CONDUCTED IN THE PRESENCE OF THE DISTRICT INSPECTOR.
13. ALL 3/4" THROUGH 2" METERS AND CUSTOMER SERVICE VALVES WILL BE FURNISHED BY MOULTON NIGUEL WATER DISTRICT FOLLOWING PROOF OF PROJECT APPROVAL AND PAYMENT. THE CONTRACTOR SHALL INSTALL ALL METERS AND CUSTOMER SERVICE VALVES. THE CONTRACTOR SHALL EXPOSE ALL ANGLE METER STOPS AND PROPERLY LOCATE THE METER BOXES TO GRADE PRIOR TO REQUESTING INSPECTION OF THE METERS AND CUSTOMER SERVICE VALVES BY THE DISTRICT.
14. ALL METERS SHALL BE INSTALLED IN GRASS OR PLANTER AREAS AND ACCESSIBLE BY VEHICLE. ANY SERVICES LOCATED IN SIDEWALKS ARE SUBJECT TO ORANGE COUNTY PUBLIC WORKS OR APPROPRIATE GOVERNING AGENCY AND DISTRICT APPROVAL. ANY METERS LOCATED IN BANKS OF 4 SHALL BE MANIFOLDED PER MNWD STANDARD DRAWING W-2. ALL METER REGISTERS AND LIDS SHALL BE MARKED WITH ADDRESS IDENTIFICATION.
15. WHERE METERS AND METER BOXES ARE LOCATED WITHIN SLOPES, THE ANGLE METER STOPS SHALL BE SO LOCATED THAT THE METERS AND BOXES WILL BE PARALLEL AND FLUSH, RESPECTIVELY, WITH THE FINISHED STREET SURFACE. A RETAINING WALL MAY BE REQUIRED AROUND THE METER BOX.
16. INDIVIDUAL PRESSURE REGULATORS SHALL BE INSTALLED AND SET PER CALIFORNIA PLUMBING CODE OR APPROPRIATE GOVERNING AGENCY'S STANDARDS.
17. CURBS SHALL BE INSCRIBED WITH A 2-INCH HIGH "W" INDICATING LOCATIONS OF ALL POTABLE WATER SERVICES.

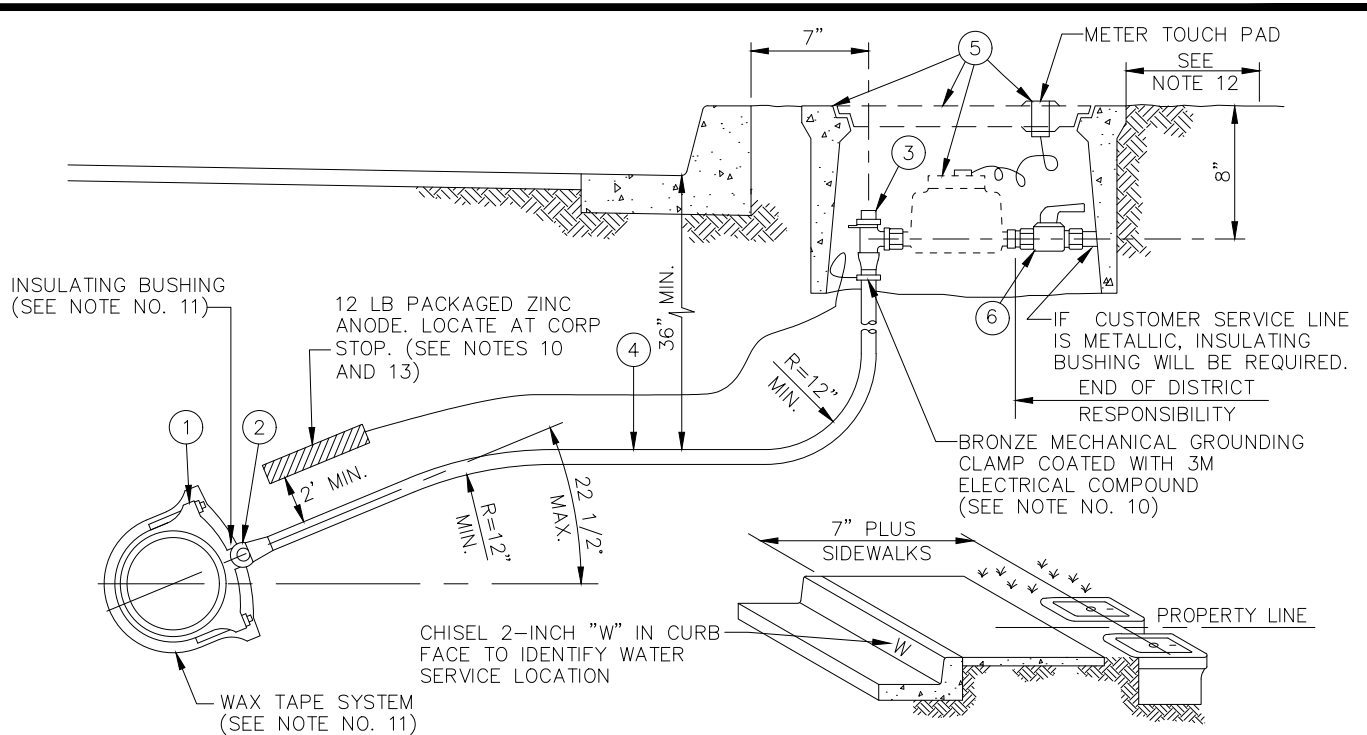

MATERIAL LIST		
ITEM	DESCRIPTION	COMMENTS
①	SERVICE SADDLE WITH I.P. THREAD	BRONZE
②	CORPORATION STOP (BALL TYPE)	I.P. THREAD X FLARE
③	ANGLE STOP (BALL TYPE)	FLARE ANGLE METER STOP
④	3/4" OR 1" COPPER TUBING	TYPE "K" SOFT
⑤	CUSTOMER METER, METER BOX, LID	PURCHASED FROM DISTRICT SET BY CONTRACTOR
⑥	CUSTOMER VALVE	PURCHASED FROM DISTRICT SET BY CONTRACTOR. METER FLANGE X F.I.P.

NOTES

- THE CORPORATION STOP TAP WILL BE MADE AS RECOMMENDED BY THE MANUFACTURER. ALL DRY TAPS WILL BE MADE BY SHELL CUTTER WITH GUIDE OR PILOT TAP.
- THE WATER SERVICE SHALL EXTEND PERPENDICULAR TO THE CENTERLINE OF THE STREET FROM THE WATER MAIN.
- SINGLE FAMILY RESIDENTIAL METERS SHALL BE LOCATED IN PAIRS AT PROPERTY LINE.
- WHEEL STOPS REQUIRED TO PREVENT VEHICLES FROM BLOCKING ACCESS TO WATER METERS.
- METER TO BE CENTERED INSIDE THE METER BOX.
- NO TAP TO MAIN SHALL BE WITHIN 18" OF A JOINT, FITTING OR ANOTHER TAP.
- SERVICE SHALL BE BACKFILLED WITH SAND, MIN. (SE 30) 6" BELOW AND ABOVE SERVICE.
- METER SIZE SHALL BE THE SAME AS THE SERVICE LINE.
- COPPER SERVICE LINE SHALL BE POLYETHYLENE SLEEVED.
- WATER SERVICES SHALL BE PROVIDED WITH A ZINC ANODE SYSTEM TO PROTECT FROM CORROSION.
- WATER SERVICES SHALL BE ISOLATED FROM STEEL AND DIP PIPELINES. PROVIDE A NYLON INSULATING BUSHING BETWEEN THE SERVICE SADDLE AND THE CORPORATION STOP. THE OUTLET SIZE ON THE SERVICE SADDLE SHALL BE INCREASED 1/2-INCH TO ACCOMMODATE THE BUSHING. WAX TAPE ON BRONZE OR STAINLESS STEEL SADDLE PER SECTION 13110. INSULATING BUSHING AND WAX TAPE REQUIRED FOR STEEL AND DIP MAINS ONLY.
- BOX SHALL BE LOCATED SO THAT MIN 12" CLEARANCE IS MAINTAINED FROM ADJACENT OBSTRUCTIONS ON ALL SIDES.
- LOCATE ANODE AT EITHER THE CORP STOP OR ANGLE STOP PER INSPECTOR'S DIRECTION.

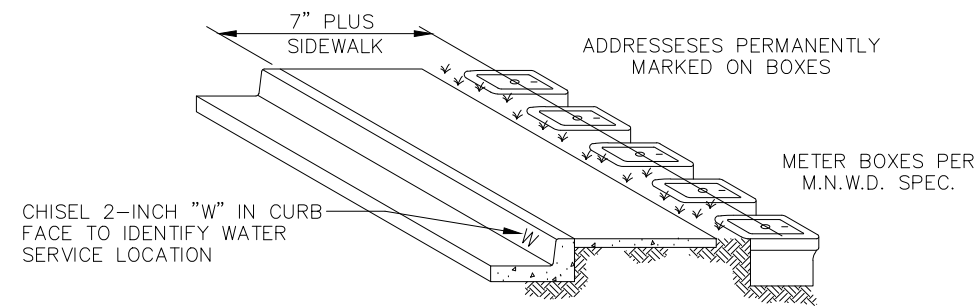

METER BOX INSTALLATION

MATERIAL LIST		
ITEM	DESCRIPTION	COMMENTS
①	SERVICE SADDLE	BRONZE
②	2" CORPORATION STOP (BALL TYPE)	I.P. THREAD X FLARE
③	2" ANGLE STOP	FLARE - GROUND ANGLE METER STOP
④	2" COPPER TUBING	TYPE "K" SOFT
⑤	METER, METER BOX, CUSTOMER VALVE	
⑥	2" 90° ELBOW	COPPER SWEAT FITTING
⑦	2" x 3/4" TEE	COPPER SWEAT FITTING
⑧	3/4" 90° ELBOW	COPPER SWEAT FITTING
⑨	3/4" COPPER	TYPE "K" SOFT
⑩	ANGLE STOP (BALL TYPE)	FLARE ANGLE METER STOP
⑪	2" WATER METER FLANGE	METER FLANGE X F.I.P.
⑫	2" ADAPTOR MIP X COPPER	COPPER SWEAT FITTING
⑬	2" x 3/4" REDUCER	

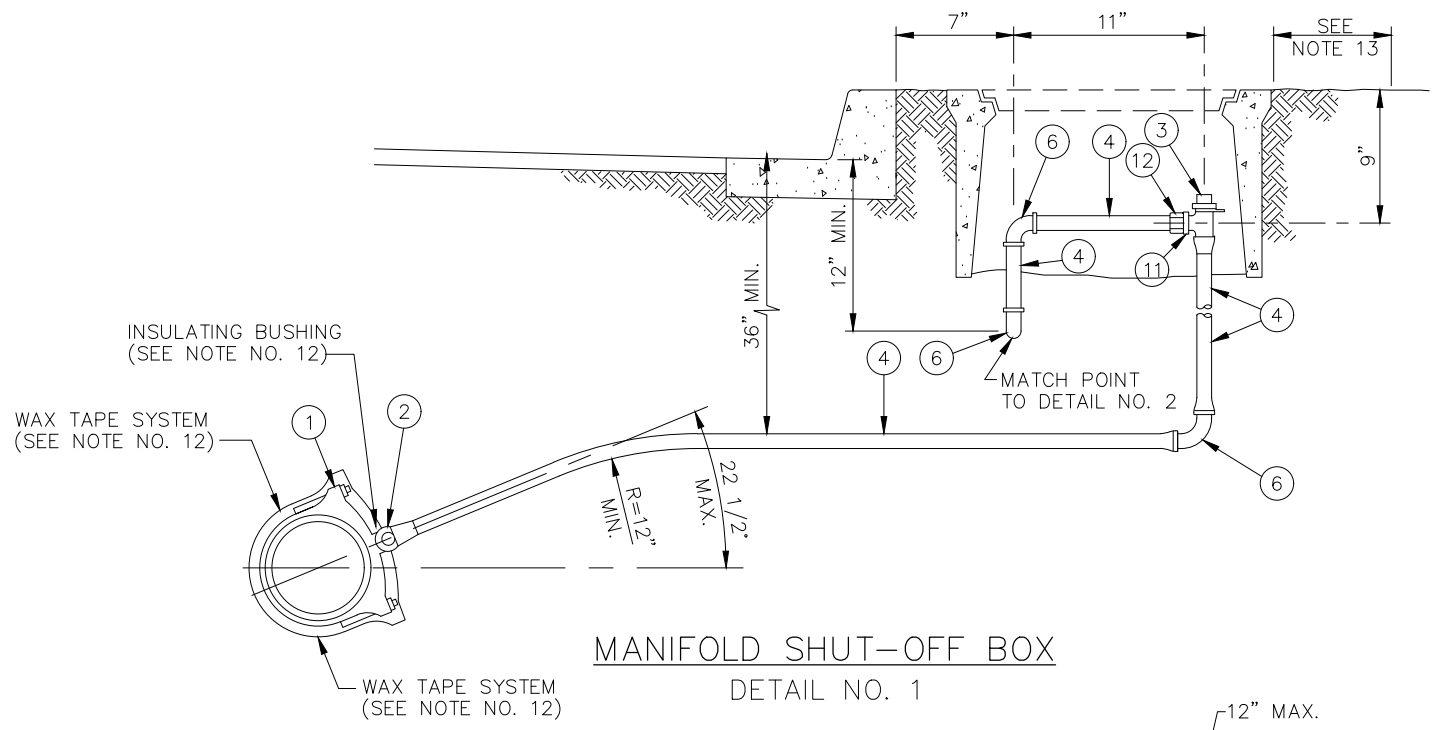

**MANIFOLD SHUT-OFF BOX
DETAIL NO. 1**

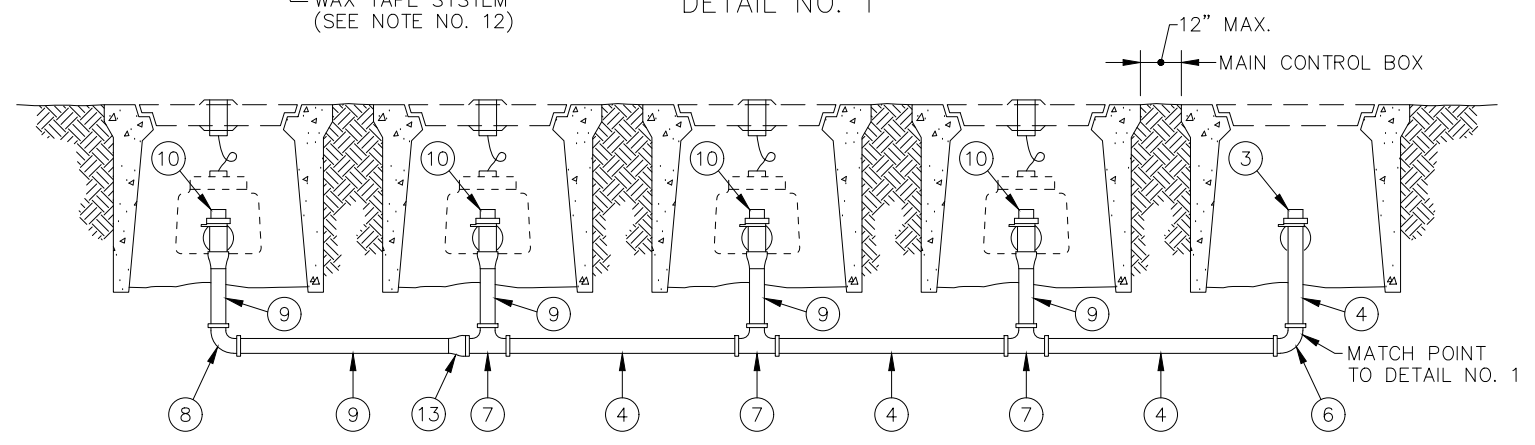

**4 METER MANIFOLD
DETAIL NO. 2**

NOTES

1. THE CORPORATION STOP TAP WILL BE MADE AS RECOMMENDED BY THE MANUFACTURER. ALL DRY TAPS WILL BE MADE BY HOLE SAW WITH GUIDE OR PILOT TAP.
2. THE WATER SERVICE SHALL EXTEND PERPENDICULAR TO THE CENTERLINE OF THE STREET FROM THE WATER MAIN.
3. SINGLE FAMILY RESIDENTIAL METERS SHALL BE LOCATED IN PAIRS AT PROPERTY LINE.
4. WHEEL STOPS REQUIRED TO PREVENT VEHICLES FROM BLOCKING ACCESS TO WATER METERS.
5. METER TO BE CENTERED INSIDE THE METER BOX.
6. NO TAP TO MAIN SHALL BE WITHIN 18" OF A JOINT, FITTING OR ANOTHER TAP.
7. SERVICE SHALL BE BACKFILLED WITH SAND, MIN. (SE 30) 6" BELOW AND ABOVE SERVICE.
8. METER SIZE SHALL BE THE SAME AS THE SERVICE LINE.
9. ALL COPPER FITTINGS SHALL BE SILVER SOLDER.
10. COPPER LINE SHALL BE POLYETHYLENE SLEEVED.
11. INSTALL ZINC ANODE SYSTEM PER STD. DWG. W-1 OR W-3 TO PROTECT FROM CORROSION.
12. WATER SERVICES SHALL BE ISOLATED FROM STEEL AND DIP PIPELINES. PROVIDE A NYLON INSULATING BUSHING BETWEEN THE SERVICE SADDLE AND THE CORPORATION STOP. THE OUTLET SIZE ON THE SERVICE SADDLE SHALL BE INCREASED 1/2-INCH TO ACCOMMODATE THE BUSHING. WAX TAPE ON BRONZE OR STAINLESS STEEL SADDLE PER SECTION 13110. INSULATING BUSHING AND WAX TAPE REQUIRED FOR STEEL AND DIP MAINS ONLY.
13. BOX SHALL BE LOCATED SO THAT MIN 12" CLEARANCE IS MAINTAINED FROM ADJACENT OBSTRUCTIONS ON ALL SIDES

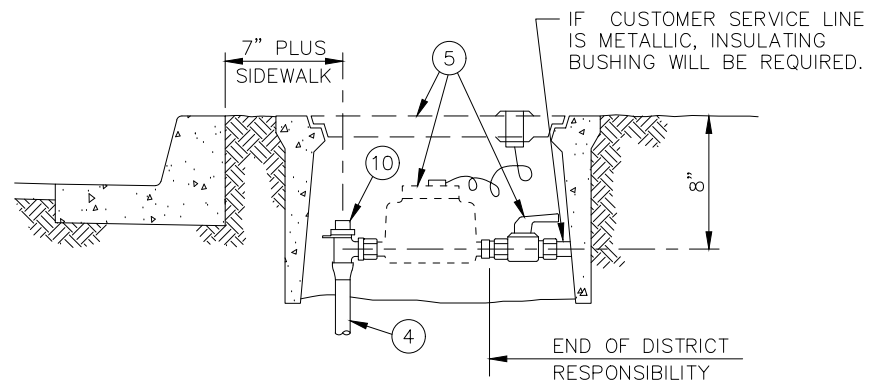

METER INSTALLATION

METER SIZE COMBINATION OPTIONS		
OPTION	METER SIZES	QUANTITY
A	1.5"	1
	1"	1
B	1.5"	1
	3/4"	2
C	1"	3
	3/4"	1
D	1"	2
	3/4"	2
E	1"	1
	3/4"	4
F	3/4"	6

MOULTON NIGUEL WATER DISTRICT

STANDARD WATER METER MANIFOLD

W-2
AUGUST 2024

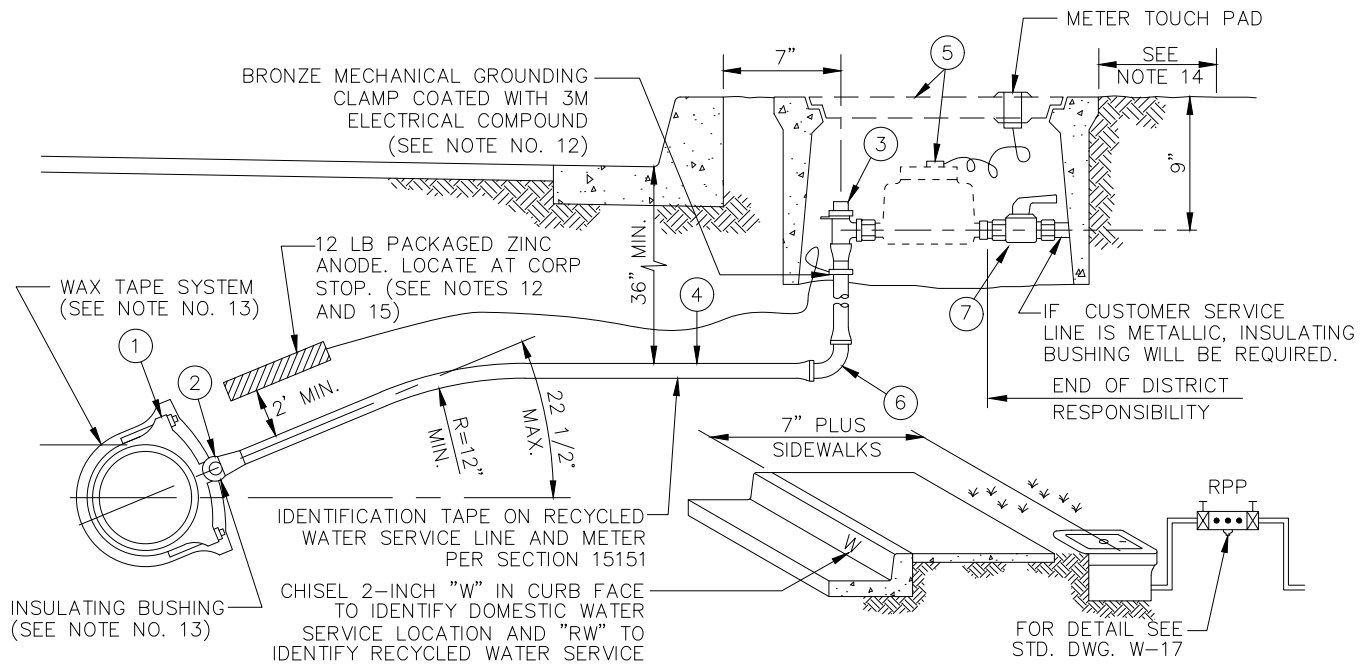

MATERIAL LIST		
ITEM	DESCRIPTION	COMMENTS
①	SERVICE SADDLE WITH I.P. THREAD	BRONZE
②	CORPORATION STOP (BALL TYPE)	I.P. THREAD X FLARE
③	ANGLE STOP	FLARE GROUND ANGLE METER STOP
④	1 1/2" OR 2" COPPER TUBING	TYPE "K" SOFT
⑤	CUSTOMER METER, METER BOX, AND LID	PURCHASED FROM DISTRICT SET BY CONTRACTOR
⑥	90°	COPPER SWEAT FITTING
⑦	CUSTOMER VALVE	PURCHASED FROM DISTRICT SET BY CONTRACTOR. METER FLANGE X F.I.P.

NOTES

- THE CORPORATION STOP TAP WILL BE MADE AS RECOMMENDED BY THE MANUFACTURER. ALL DRY TAPS WILL BE MADE BY MACHINE WITH GUIDE OR PILOT TAP.
- THE WATER SERVICE SHALL EXTEND PERPENDICULAR TO THE CENTERLINE OF THE STREET FROM THE WATER MAIN.
- METER TO BE CENTERED INSIDE THE METER BOX.
- WHEEL STOPS REQUIRED TO PREVENT VEHICLES FROM BLOCKING ACCESS TO WATER METERS.
- WHEN BACKFLOWS ARE REQUIRED, LOCATION WILL BE DETERMINED AT DISTRICT DISCRETION. GENERALLY BACKFLOW IS INSTALLED ADJACENT TO WATER METER.
- ALL 1 1/2" AND 2" SERVICES WILL BE LOCKED "OFF" AFTER NEW MAIN IS TIED IN.
- NO TAP TO MAIN SHALL BE WITHIN 18" OF A JOINT, FITTING OR ANOTHER TAP.
- SERVICE SHALL BE BACKFILLED WITH SAND, MIN. (SE 30) 6" BELOW AND ABOVE SERVICE.
- METER SIZE SHALL BE THE SAME AS THE SERVICE LINE.
- ALL COPPER FITTINGS SHALL BE SILVER SOLDER.
- ALL SERVICE LINES SHALL BE POLYETHYLENE SLEEVED.
- WATER SERVICES SHALL BE PROVIDED WITH A ZINC ANODE SYSTEM TO PROTECT FROM CORROSION.
- WATER SERVICES SHALL BE ISOLATED FROM STEEL AND DIP PIPELINES. PROVIDE A NYLON INSULATING BUSHING BETWEEN THE SERVICE SADDLE AND THE CORPORATION STOP. THE OUTLET SIZE ON THE SERVICE SADDLE SHALL BE INCREASED 1/2-INCH TO ACCOMMODATE THE BUSHING. WAX TAPE ON BRONZE OR STAINLESS STEEL SADDLE PER SECTION 13110. INSULATING BUSHING AND WAX TAPE REQUIRED FOR STEEL AND DIP MAINS ONLY.
- BOX SHALL BE LOCATED SO THAT MIN. 12" CLEARANCE IS MAINTAINED FROM ADJACENT OBSTRUCTIONS ON ALL SIDES.
- LOCATE ANODE AT EITHER THE CORP STOP OR ANGLE STOP PER INSPECTOR'S DIRECTION.

MOULTON NIGUEL WATER DISTRICT
STANDARD 1-1/2" & 2" WATER SERVICE

W-3
AUGUST 2024

CONSTRUCTION ITEMS

- ① COMMERCIAL CUSTOMER METER WITH RADIO TRANSMITTER UNIT
- ② FLANGED COUPLING ADAPTER
- ③ DUCTILE IRON SPOOL FLG x P.E., 1'-0" LONG
- ④ DUCTILE IRON FLANGED x P.E. SPOOL
- ⑤ DUCTILE IRON BLIND FLANGE
- ⑥ RESILIENT WEDGE VALVE, FLANGED, NRS WITH HANDWHEEL
- ⑦ PRECAST METEER VAULT - SEE TABLE W-4
- ⑧ I.P. SERVICE SADDLE
- ⑨ GALVANIZED LADDER
- ⑩ DUCTILE IRON FLG x FLG SPOOL
- ⑪ ALUMINUM VAULT FRAME AND COVER
- ⑫ PIPE SUPPORTS
- ⑬ PEA GRAVEL, 12" MINIMUM THICKNESS
- ⑭ 2" MIP X SWEAT ADAPTER
- ⑮ 2"-90° ELL SWEAT FITTING
- ⑯ 2" BALL CORPORATION STOP MIP X FIP VALVE
- ⑰ 2" COPPER (TYPE "K")
- ⑱ 2" BYPASS METER
- ⑲ 2" CHECK VALVE, METER FLANGE X FIP
- ⑳ 2" METER FLANGE X 2" FIP
- ㉑ TOUCH READ DEVICE (SEE INSTALLATION DETAIL)

METER SIZE	VAULT SIZE (MIN.)	
	"A"	"B"
3"	4'	6.5'
4"	4'	6.5'
6"	5'	8.5'
8"	5'	8.5'

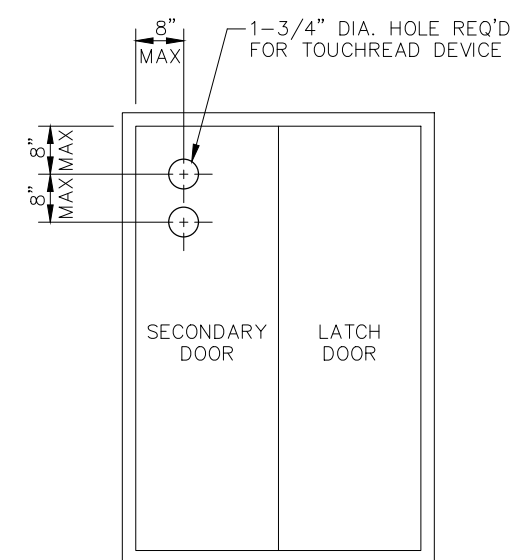
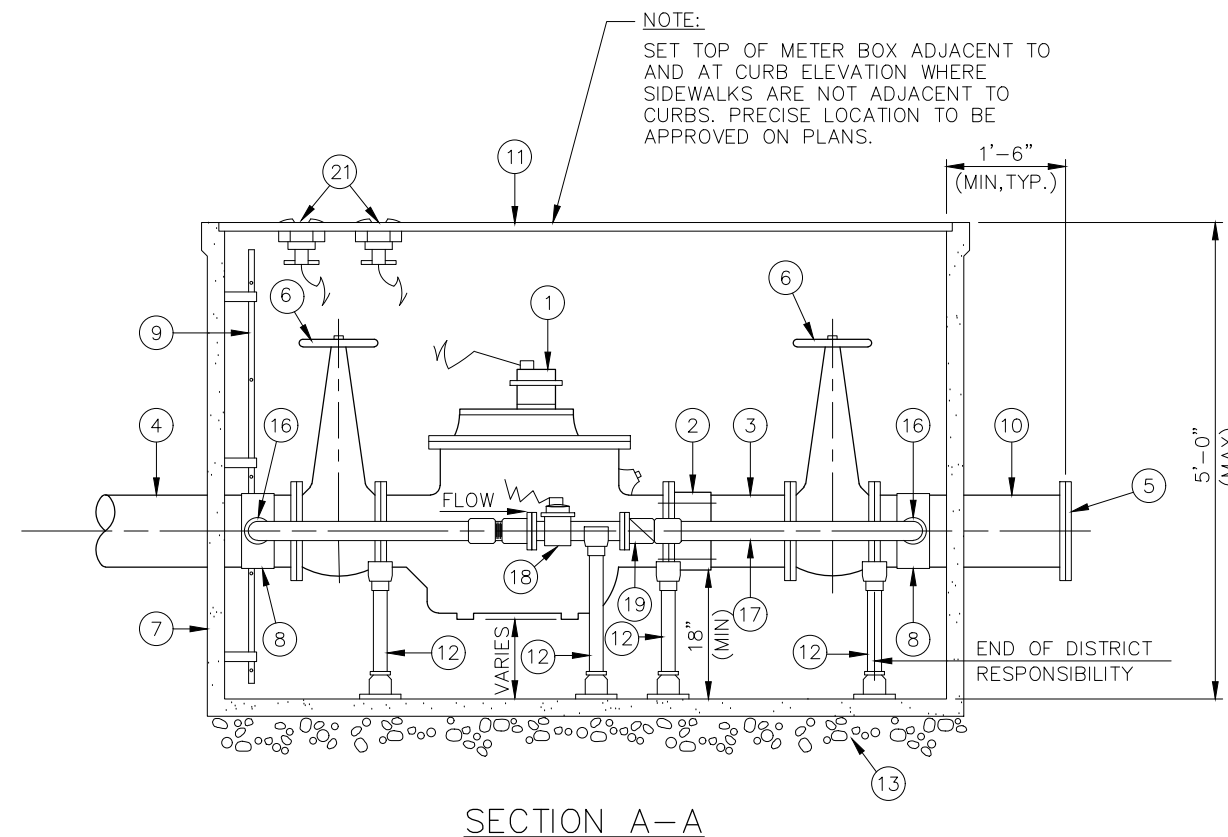
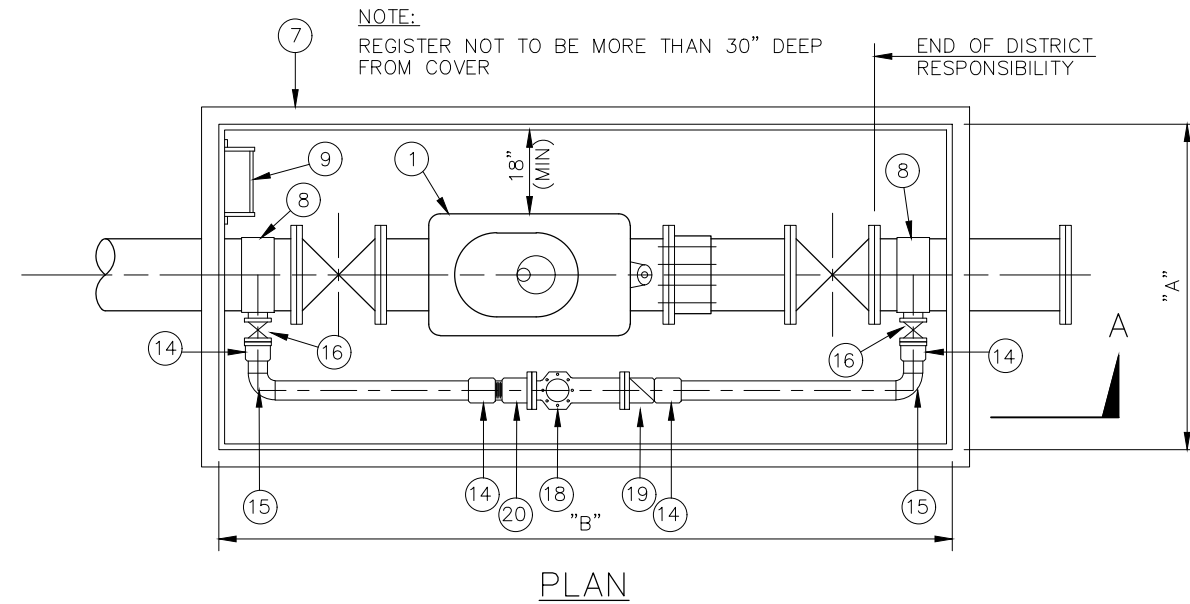

VAULT LID PLAN VIEW
FIG. 1

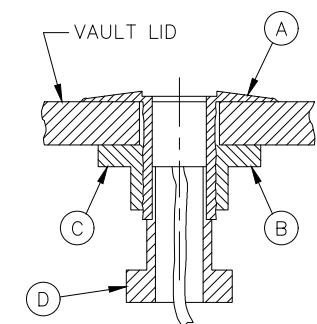

INSTALLING DEVICE

1. AS IN FIG. 1. DRILL 1-3/4" DIA. HOLE THROUGH VAULT LID
2. INSERT SENSOR HOUSING (A) THROUGH VAULT LID HOLE FROM ABOVE AND TIGHTEN SECURELY IN PLACE WITH PLASTIC NUT (B).
3. INSERT SENSOR ASSEMBLY (C) CONNECTED TO METERS REGISTER INTO HOUSING AND SECURE IN PLACE WITH SCREW PLUG (D).
4. EXCESS WIRE SHOULD BE COILED LOOSELY (NOT TIED) IN METER VAULT ALLOWING SLACK FOR VAULT LID TO SWING OPEN.

INSTALLATION DETAILS OF TOUCHREAD DEVICE

MOULTON NIGUEL WATER DISTRICT

3", 4", 6", AND 8" STANDARD METER
COMMERCIAL CONTINUOUS FLOW METER

W-4
AUGUST 2024

CONSTRUCTION ITEMS

- ① STRAINER
- ② IRRIGATION CUSTOMER METER WITH RADIO TRANSMITTER UNIT
- ③ 2" BRASS PLUG
- ④ 2" BALL CORPORATION STOP MIP X FIP
- ⑤ RESILIENT WEDGE VALVE, FLANGED, NRS WITH HANDWHEEL
- ⑥ PIPE SUPPORTS
- ⑦ 2" SERVICE SADDLE (INSTALLED MINIMUM 3 PIPE DIAMETERS FROM DOWNSTREAM SIDE OF METER)
- ⑧ FLG. x P.E. D.I.P. SPOOL
- ⑨ PRECAST CONCRETE VAULT
- ⑩ FLANGED COUPLING ADAPTER
- ⑪ TOUCH-READ DEVICE (SEE INSTALLATION DETAIL)
- ⑫ GALVANIZED LADDER
- ⑬ PEA GRAVEL, 12" MINIMUM THICKNESS
- ⑭ D.I.P. MAIN LINE, MIN. 6" DIA. PIPE FROM MAIN LINE TO VAULT

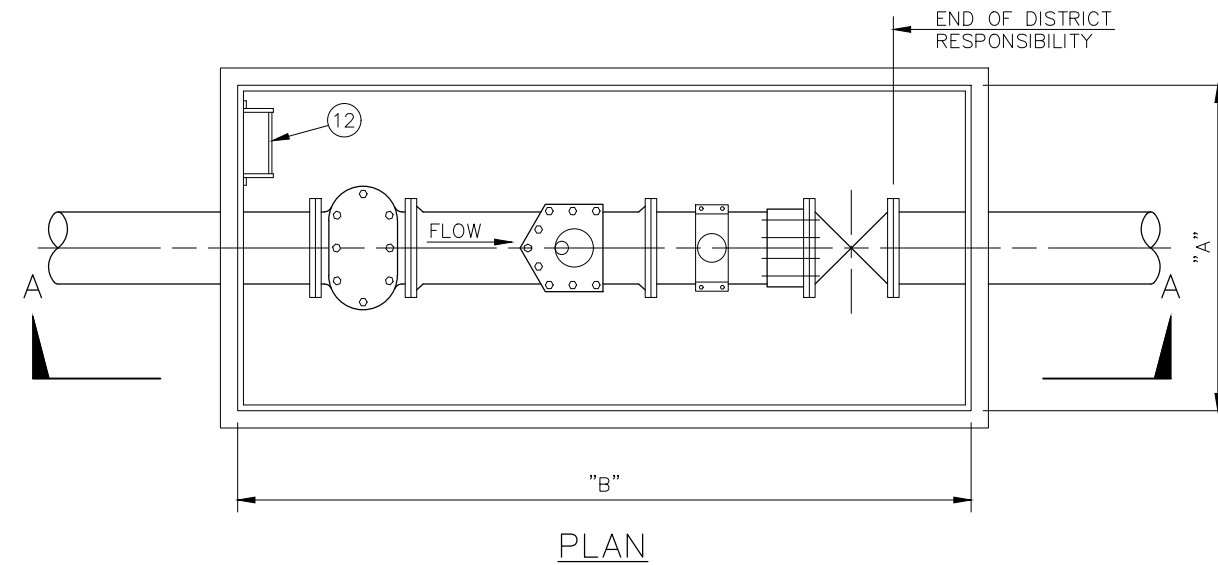

METER SIZE	VAULT SIZE (MIN.)	
	"A"	"B"
3"	4'	6.5'
4"	4'	6.5'
6"	5'	8.5'
8"	5'	8.5'

NOTE
IDENTIFICATION TAPE AND WARNING TAG ON RECYCLED WATER SYSTEM PER SECTION 15151

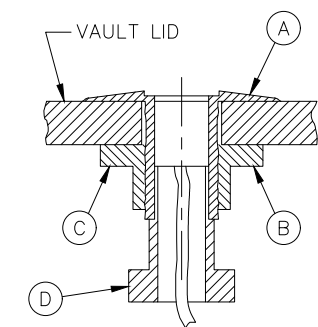
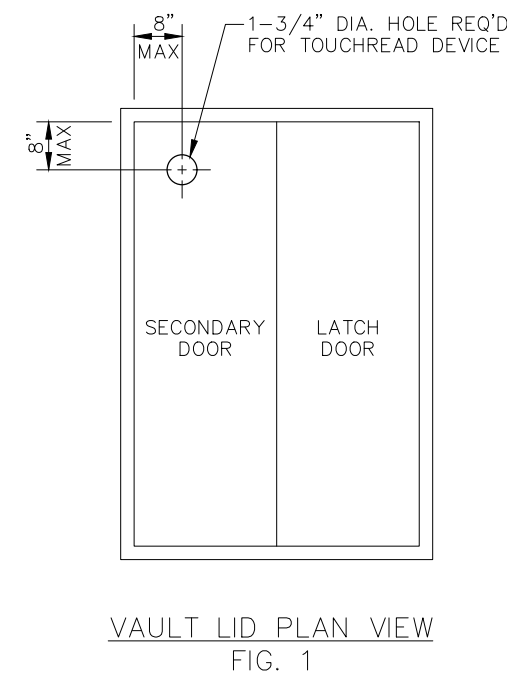
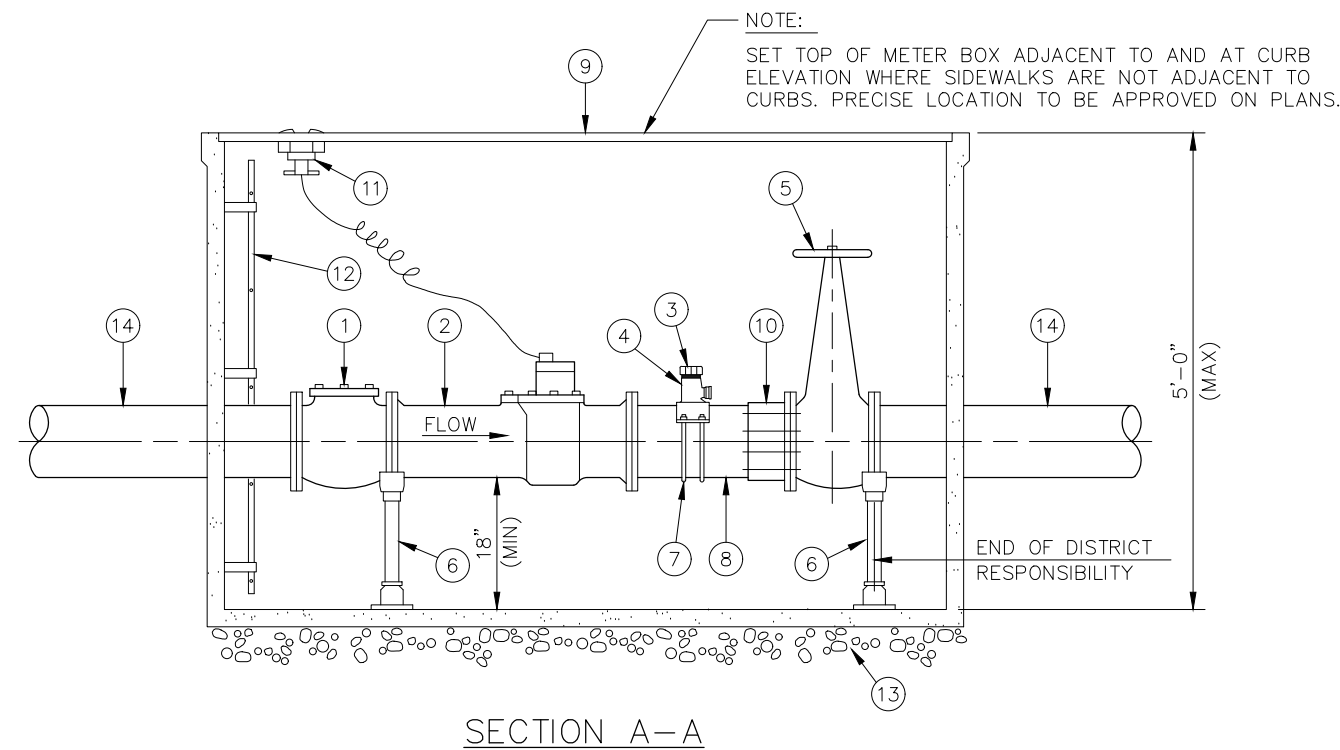

1. DRILL 1-3/4" DIA. HOLE THROUGH VAULT LID AS IN FIG. 1.
2. INSERT SENSOR HOUSING (A) THROUGH VAULT LID HOLE FROM ABOVE AND TIGHTEN SECURELY IN PLACE WITH PLASTIC NUT (B).
3. INSERT SENSOR ASSEMBLY (C) CONNECTED TO METERS REGISTER INTO HOUSING AND SECURE IN PLACE WITH SCREW PLUG (D).
4. EXCESS WIRE SHOULD BE COILED LOOSELY (NOT TIED) IN METER VAULT ALLOWING SLACK FOR VAULT LID TO SWING OPEN.

INSTALLATION DETAILS OF TOUCHREAD DEVICE

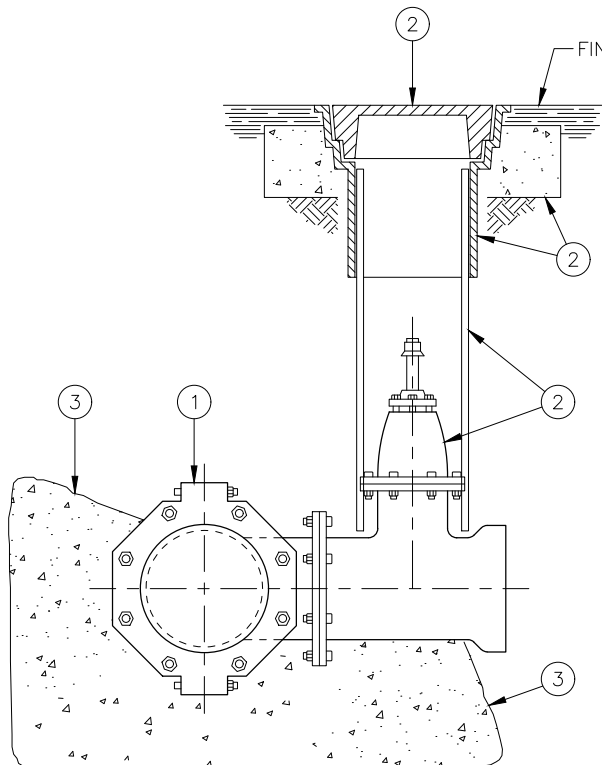

- ① TAPPING SLEEVE
- ② VALVE AND VALVE RISER BOX PER DWG. W-8. VALVE TO BE FLANGED X P.O. FULL PORT
- ③ CONSTRUCT CONCRETE THRUST BLOCK PER STD. DWG. W-12

NOTES

1. AIR TEST TAPPING SLEEVE PRIOR TO TAP
2. ALL BOLTS AND HARDWARE TO BE 316 S.S. COAT ALL TAPPING SLEEVE BOLTS WITH CORROSION GUARD
3. USE SHELL CUTTER ON ALL PVC TAPS
4. THE TAP SHALL NOT BE CLOSER THAN 18" TO A VALVE, COUPLING, JOINT, OR FITTING.

TAP OF ACP, PVC OR D.I.P. MAINS

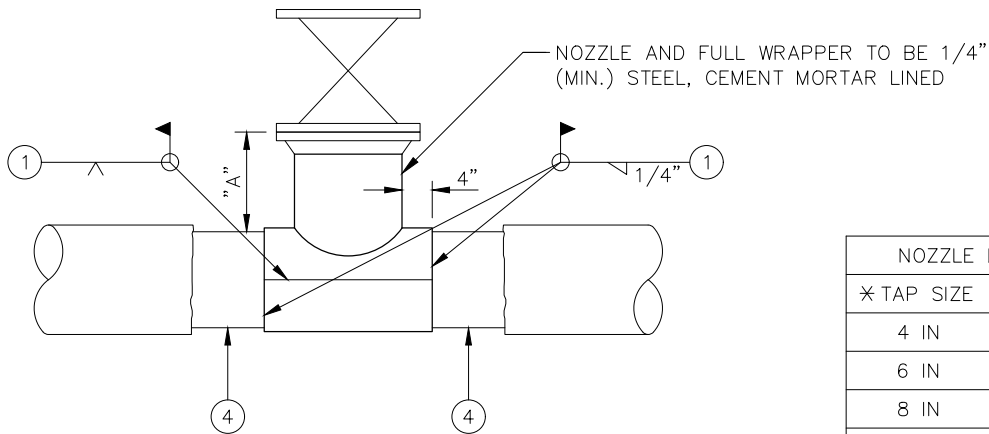

PLAN

NOZZLE DIMENSIONS	
* TAP SIZE	DIMENSION "A"
4 IN	5 IN
6 IN	6 IN
8 IN	6 3/4 IN
10 IN	7 IN
12 IN	7 1/2 IN

CONSTRUCTION STEPS

- ① WELD NOZZLE TO PIPE
- ② HYDROSTATIC TEST THE NOZZLE
- ③ TAP PIPE
- ④ INSTALL WIRE MESH AND MORTAR OVER EXPOSED STEEL

NOTE

1. CONTRACTOR TO PERFORM ALL POTHOLES, MEASUREMENTS, VERIFICATION OF MATERIALS, ETC. PRIOR TO ORDERING MATERIAL
2. THE TAP SHALL NOT BE CLOSER THAN 18" TO A VALVE, COUPLING, JOINT, OR FITTING.

TAP OF STEEL MAINS

MOULTON NIGUEL WATER DISTRICT

HOT TAP

W-6
AUGUST 2024

NOTES

1. FIRE HYDRANT SHALL BE INSTALLED WITH 4" OUTLET PERPENDICULAR TO THE CURB FACE.
2. FIRE HYDRANT SHALL BE PAINTED PER SECTION 09900.
3. 4" GUARD POSTS MAY BE REQUIRED, AS DIRECTED BY THE DISTRICT.
4. WHERE SLOPE IS ADJACENT TO FIRE HYDRANT A RETAINING WALL MAY BE REQUIRED AS DIRECTED BY THE DISTRICT.
5. 12" MINIMUM CLEARANCE FROM FIRE HYDRANT TO EDGE OF SIDEWALK.
6. IF HYDRANT LATERAL IS 8" OR LARGER, THE HORIZONTAL DISTANCE BETWEEN REDUCER AND BURY EL SHALL BE NO MORE THAN 4'.
7. SECURE TRACER WIRE BETWEEN ONE BOLT AND FLANGE WITH AN EXTRA 1" LOOP OF WIRE.

MATERIAL LIST	
ITEM	DESCRIPTION
①	RESIDENTIAL FIRE HYDRANT COMMERCIAL/INDUSTRIAL FIRE HYDRANT
②	6" LONG RADIUS CAST-IRON OR DUCTILE-IRON BURY EL (P.O. X FLG.)
③	6" PUSH-ON x FLG RESILIENT WEDGE VALVE
④	6" PUSH-ON x FLG TEE
⑤	6" BREAK-OFF CHECK VALVE, DUCTILE IRON
⑥	VALVE BOX AND RISER PER STD. DWG. W-8
⑦	6" DIA C.I. BREAK-OFF SPOOL

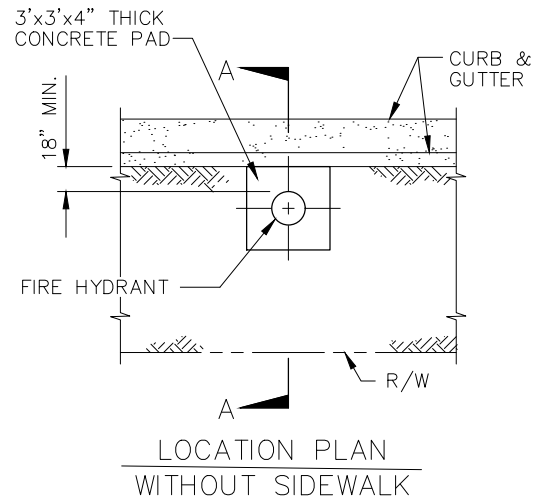
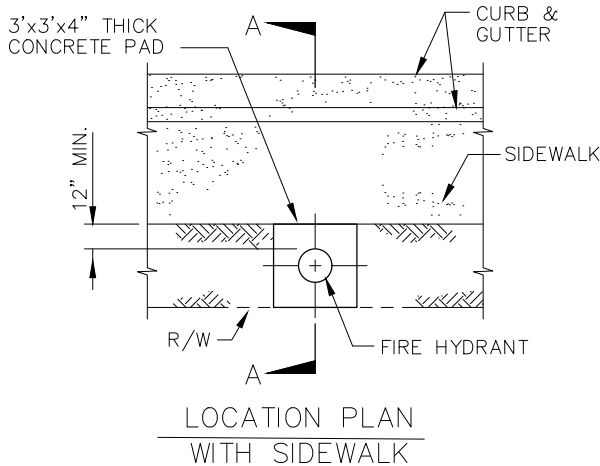
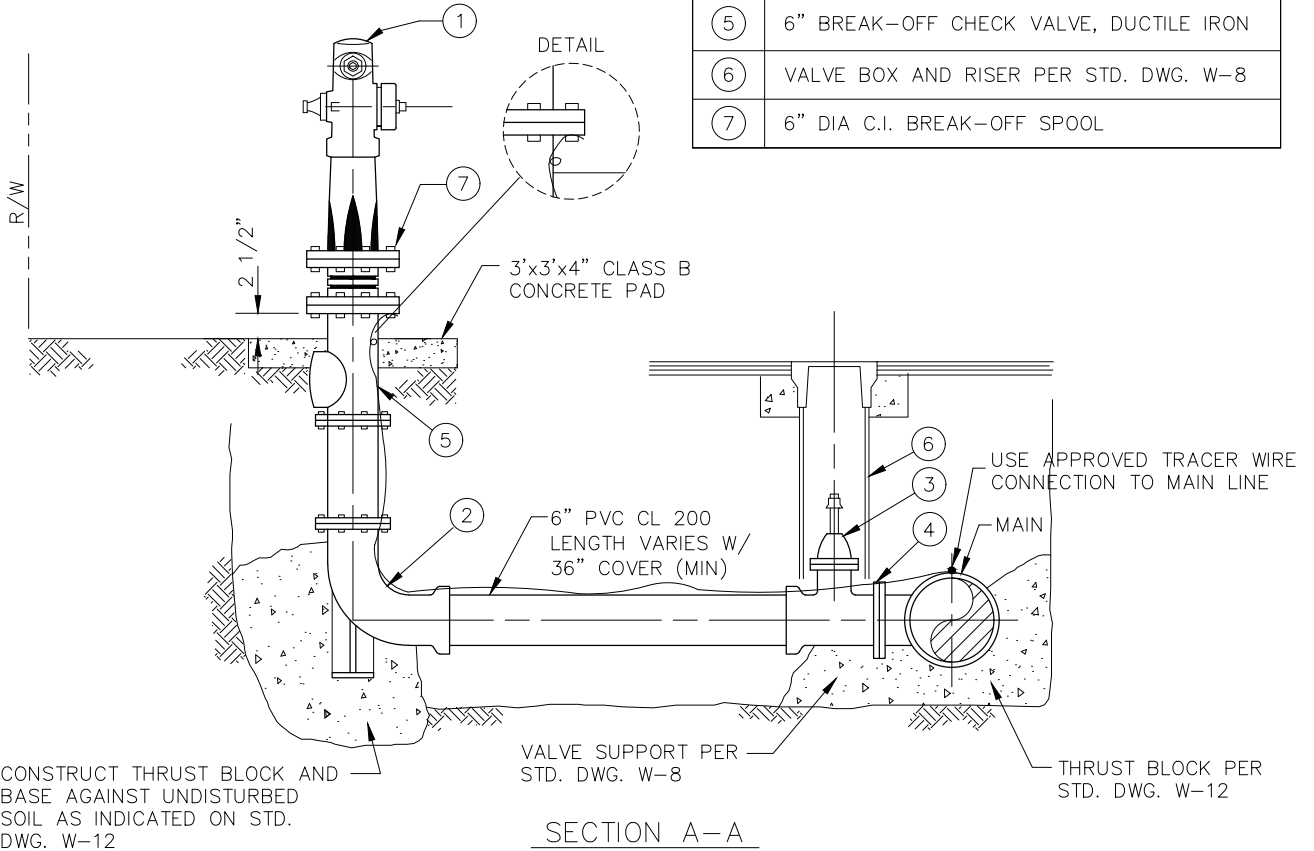

FIRE HYDRANT LOCATION

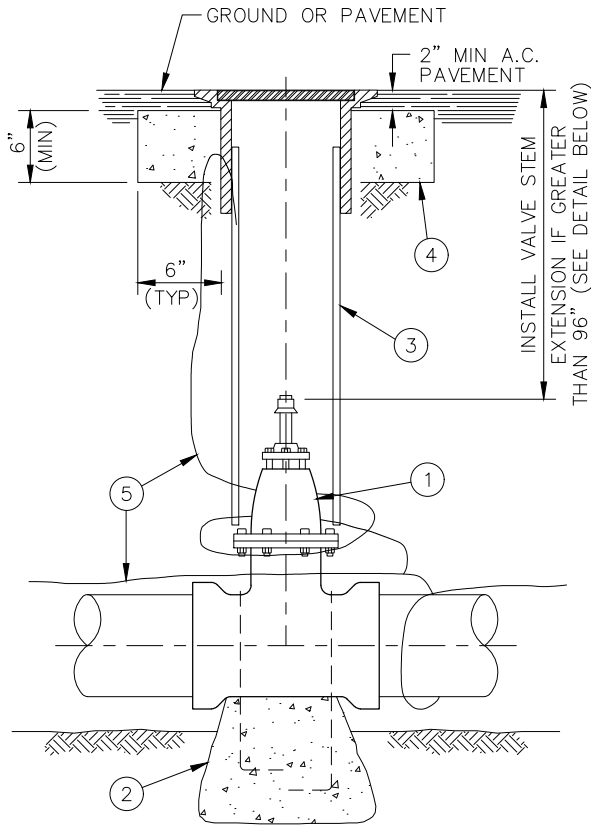

VALVE ASSEMBLY

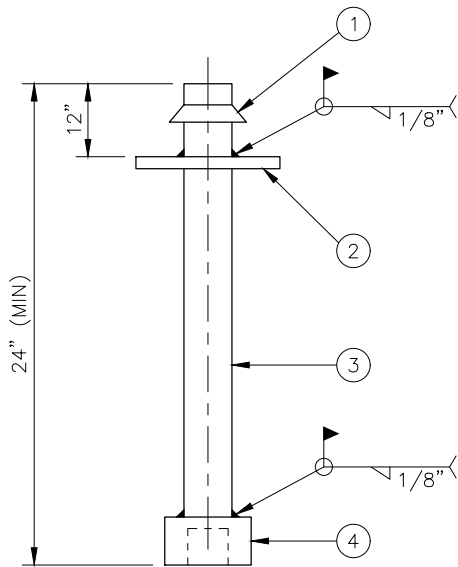

VALVE STEM EXTENSION

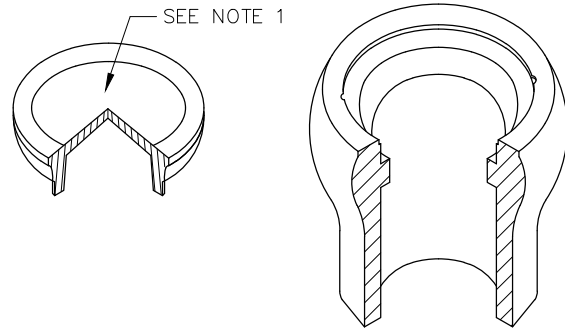

VALVE BOX

- ① RESILIENT WEDGE GATE VALVE
- ② CONCRETE VALVE ANCHOR BLOCK PER DWG W-12.
- ③ 8" SDR35 PVC VALVE RISER AND CAST IRON VALVE BOX. TOP MARKED PER NOTE 1.
- ④ CLASS B CONCRETE
- ⑤ NO. 10 GAGE LOCATING WIRE (PVC MAINS ONLY)

NOTES

1. VALVE BOX AND LID: COVERS WITH "WATER" ON POTABLE WATER SYSTEM AND "RECYCLED" ON RECYCLED WATER SYSTEM
2. ALL VALVE LOCATIONS SHALL BE CHISELED ON CURB FACE WITH 2-INCH HIGH "V".
3. ORIENT BUTTERFLY VALVE WITH OPERATOR TO THE RIGHT WHEN LOOKING TOWARD FITTING.
4. THE CONTRACTOR SHALL BE RESPONSIBLE FOR RAISING VALVE BOXES TO GRADE AFTER STREET IS PAVED 1ST LIFT, 2ND LIFT.
5. WHEN RAISING VALVE CANS, EXCAVATE TO RISER, CUT OFF SECTION OF EXISTING RISER, INSTALL NEW BELL-END 8" SDR 35 PVC RISER AT SUFFICIENT LENGTH TO ACCOMMODATE FINAL FINISHED SURFACE, AND INSTALL VALVE BOX. SCORE PLAIN-END OF RISER TO ACCOMMODATE VALVE BOX. IN LIEU OF BELL END PIPE, A PLAIN-END RISER AND BANDED FLEXIBLE COUPLING WITH 316 SST STRAPS MAY BE USED.

- ① A.W.W.A. 2" SQUARE OPERATING NUT
- ② 5" DIA. x 3/16" SPACER PLATE 12" BELOW TOP OF OPERATING NUT
- ③ 1 1/4" STAINLESS ROUND OR SQUARE STOCK (PINNED COUPLERS ARE NOT ALLOWED)
- ④ SOCKET FOR 2" SQUARE OPERATING NUT

NOTES

1. PROVIDE VALVE STEM EXTENSION WHEN DEPTH TO TO VALVE NUT EXCEEDS 96" INCHES (FABRICATE EXTENSION TO FIELD MEASUREMENT - SEE NOTE 2)
2. NO VALVE STEM EXTENSION SHALL BE LESS THAN 24" IN LENGTH. TERMINATE EXTENSION 24" TO 30" FROM FINISHED GRADE.
3. PROVIDE ADDITIONAL SPACER PLATE WHEN DISTANCE TO BOTTOM SOCKET EXCEEDS 5 FEET.

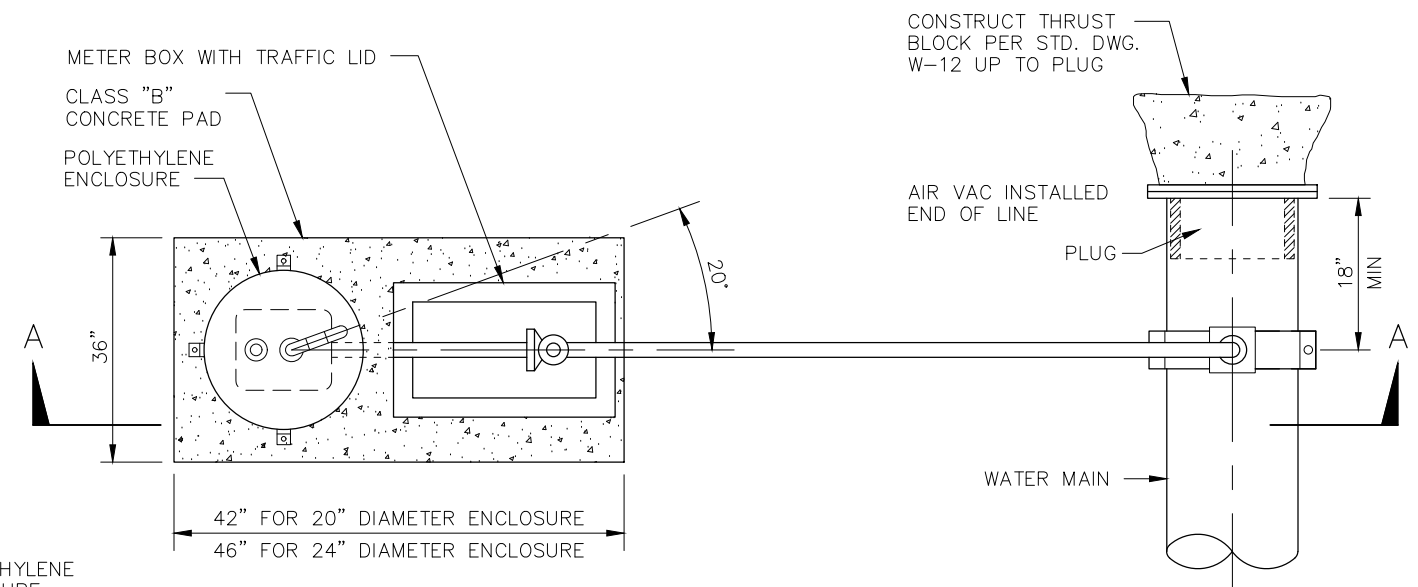
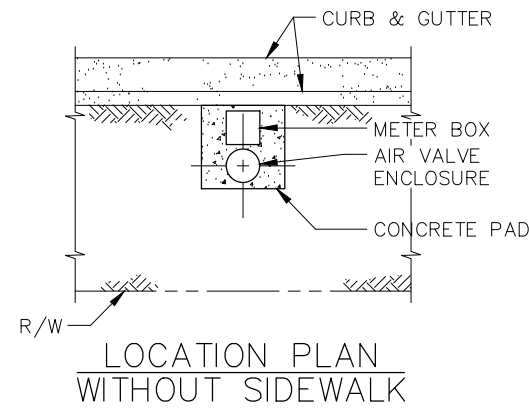
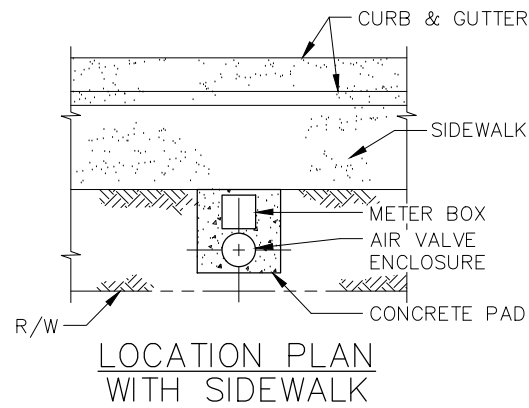

MATERIAL LIST FOR 1" AND 2"		
ITEM	DESCRIPTION	MATERIAL
①	COMB. AIR RELIEF & VACUUM RELEASE VALVE	REINFORCED NYLON
②	STRAP SERVICE SADDLE	BRONZE
③	90° STREET ELBOW	BRASS
④	CORPORATION STOP	
⑤	TUBING	TYPE "K" COPPER
⑥	ANGLE METER STOP	BRONZE
⑦	NIPPLE	BRASS
⑧	90° ELBOW	BRASS
⑨	BALL VALVE WITH HANDLE	BRONZE
⑩	SHORT NIPPLE	BRASS
⑪	NOT USED	-
⑫	DISCHARGE OUTLET	POLYPROPYLENE
⑬	NOT USED	-
⑭	TEE	BRASS
⑮	SHORT NIPPLE	STAINLESS STEEL
⑯	4" DIA x 8" LONG PVC PIPE SPOOL	SCH 80 PVC
⑰	FLG X FEMALE THREAD ADAPTER	BRASS

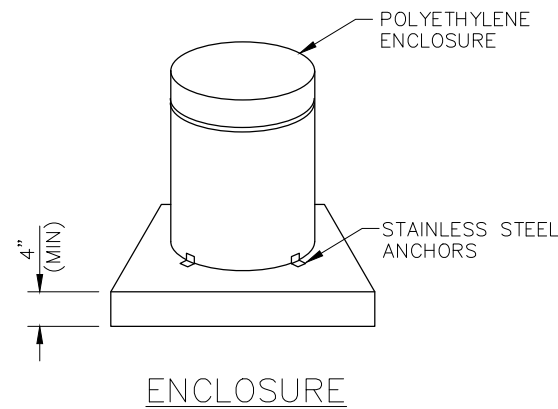

"WARNING TAG" FOR RECYCLED WATER MAIN

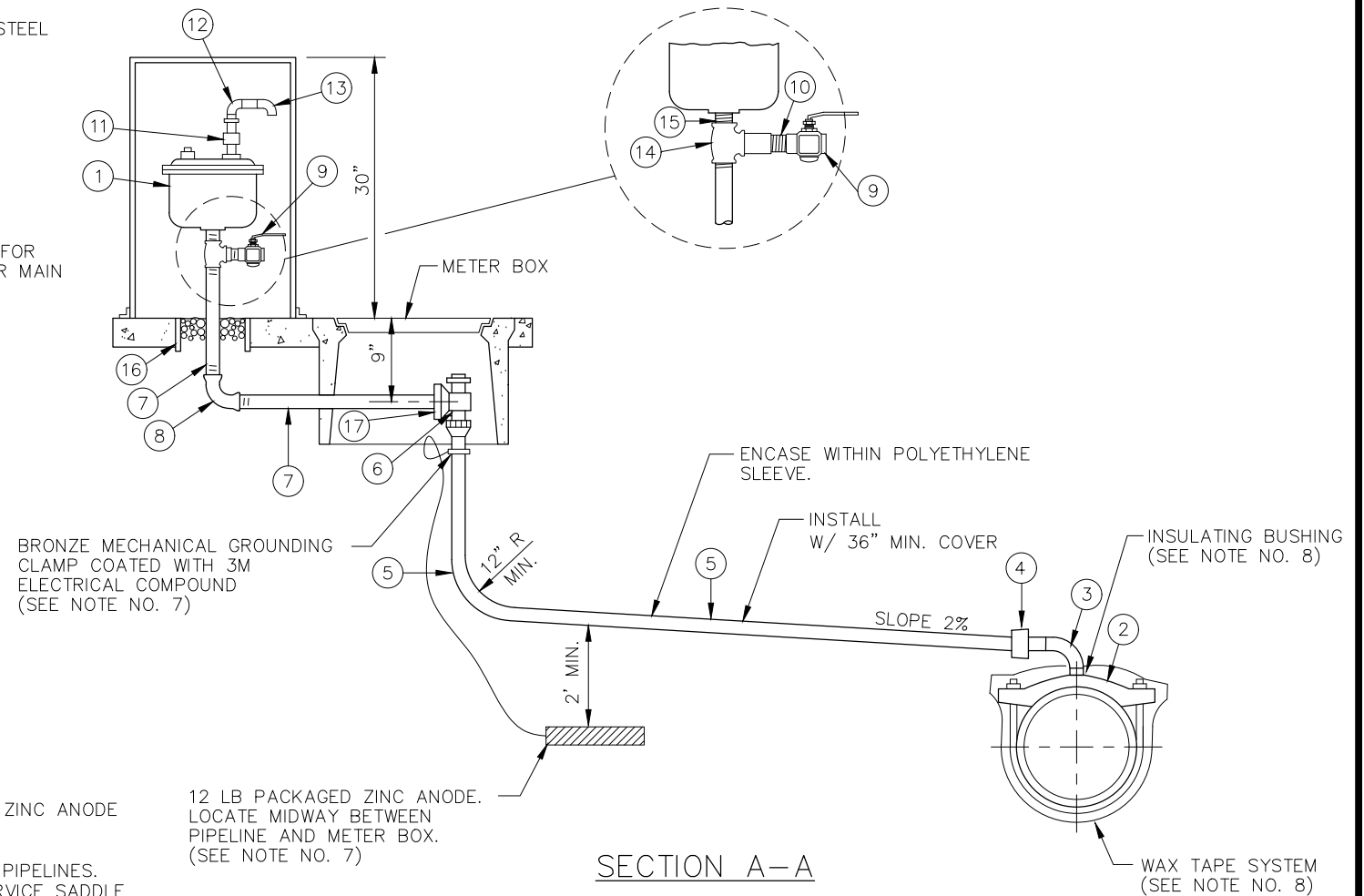

NOTES

- FOR PIPELINES LARGER THAN 10" THE DISTRICT WILL DETERMINE SIZE OF AIR AND VACUUM RELEASE VALVE.
- RETAINING WALL MAY BE REQUIRED WHEN ADJACENT TO SLOPES.
- FURNISH FITTINGS OF LIKE MATERIAL AS REQUIRED.
- SEE PROJECT PLAN DETAIL FOR MATERIAL LIST FOR ASSEMBLIES 3" AND LARGER.
- ORIENT OUTLET ON TOP OF PIPE.
- INSTALL IDENTIFICATION TAPE ON SERVICE LINE AND WARNING TAG ON BALL VALVE FOR RECYCLED WATER SYSTEM PER SECTION 15151.
- COPPER LINE SHALL BE POLYETHYLENE SLEEVED.
- COMB. AIR VALVE ASSEMBLY SHALL BE PROVIDED WITH A ZINC ANODE SYSTEM TO PROTECT FROM CORROSION.
- ISOLATE COPPER TUBING LATERALS FROM STEEL AND DIP PIPELINES. PROVIDE A NYLON INSULATING BUSHING BETWEEN THE SERVICE SADDLE AND THE CORPORATION STOP. THE OUTLET SIZE ON THE SERVICE SADDLE SHALL BE INCREASED 1/2-INCH TO ACCOMODATE THE BUSHING. WAX TAPE OF BRONZE SADDLE PER SECTION 13110. INSULATING BUSHING AND WAX TAPE REQUIRED FOR STEEL AND DIP MAINS ONLY.
- FILL 8" DIA PVC COLLAR WITH 8" OF 3/4" CRUSHED ROCK.

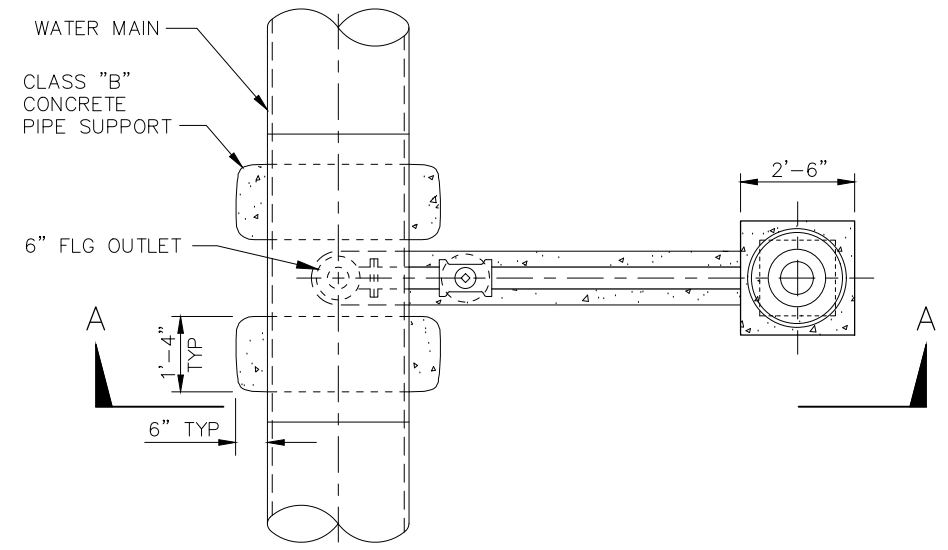

PLAN

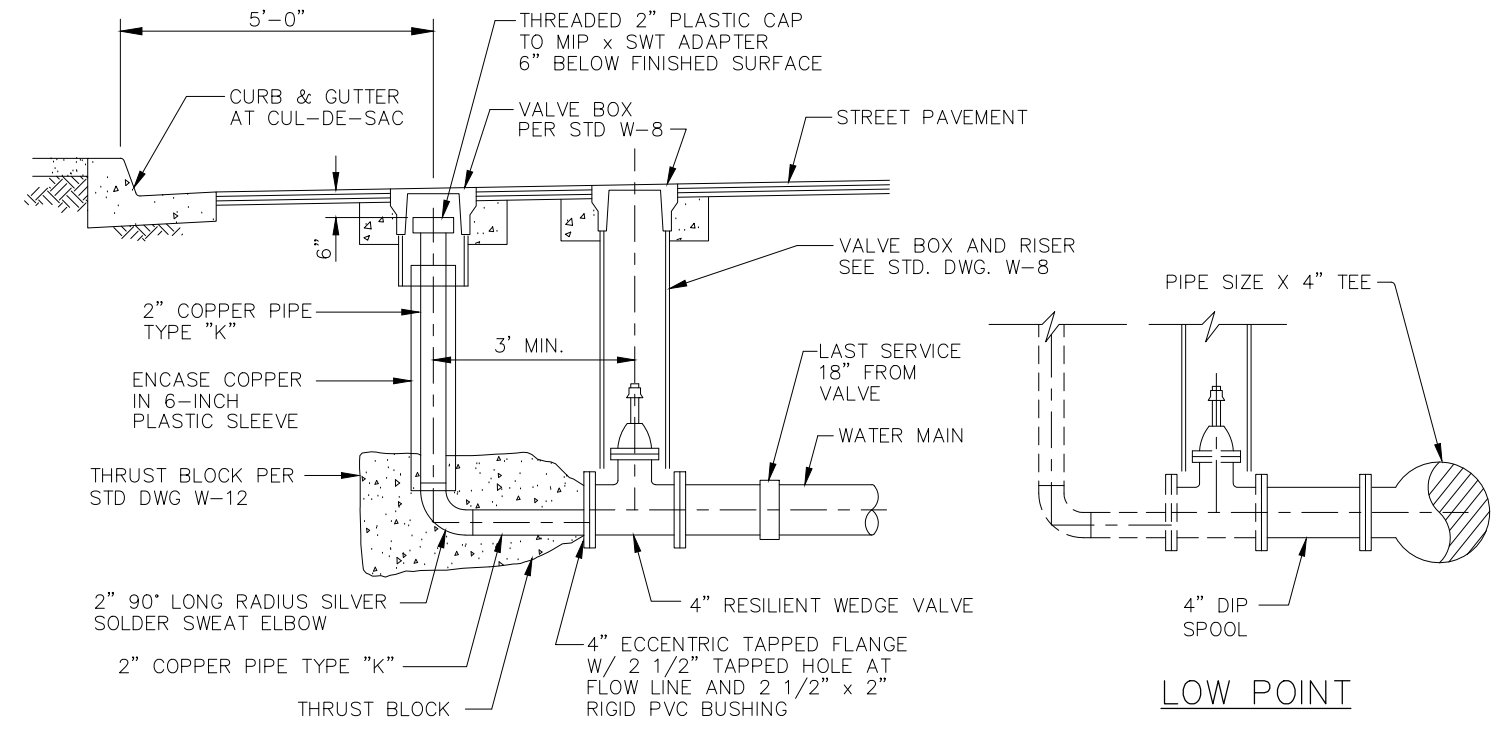

DEAD-END

LOW POINT

BLOW-OFF FOR DEAD-END STREET OR LOW POINT IN PIPELINE

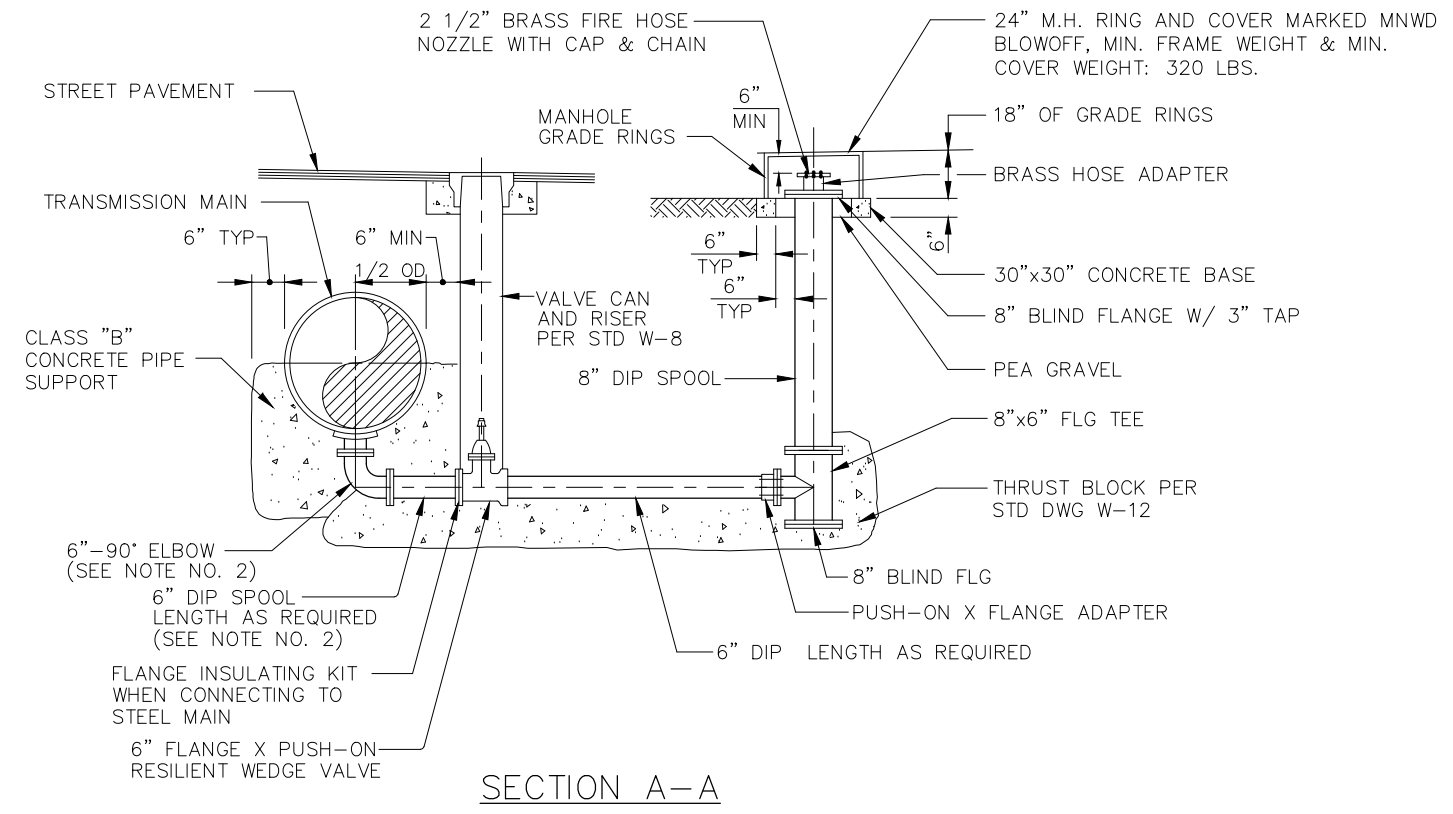

SECTION A-A

6" BLOW-OFF FOR LOW POINT OF LINE FOR WATER MAINS 12" DIA. AND LARGER

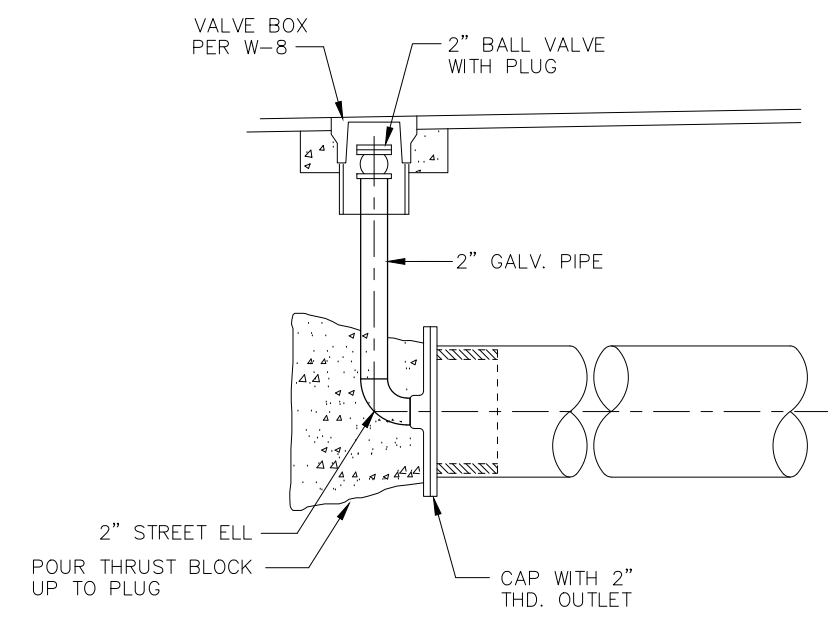

TEMPORARY PLUG & BLOWOFF

NOTES:

1. INSTALL IDENTIFICATION TAPE ON PIPING AND WARNING TAG ON OUTLET CAP AND PLUG FOR RECYCLED WATER SYSTEM PER SECTION 15151.
2. WHEN CONNECTING TO STEEL MAIN, THE 90° ELBOW AND SPOOL SHALL BE STEEL. INSTALL BOND WIRES ACROSS STEEL FLANGES UPSTREAM OF VALVE PER STD. DWG. NO. W-24. WAX TAPE BURIED EXPOSED STEEL SURFACES.

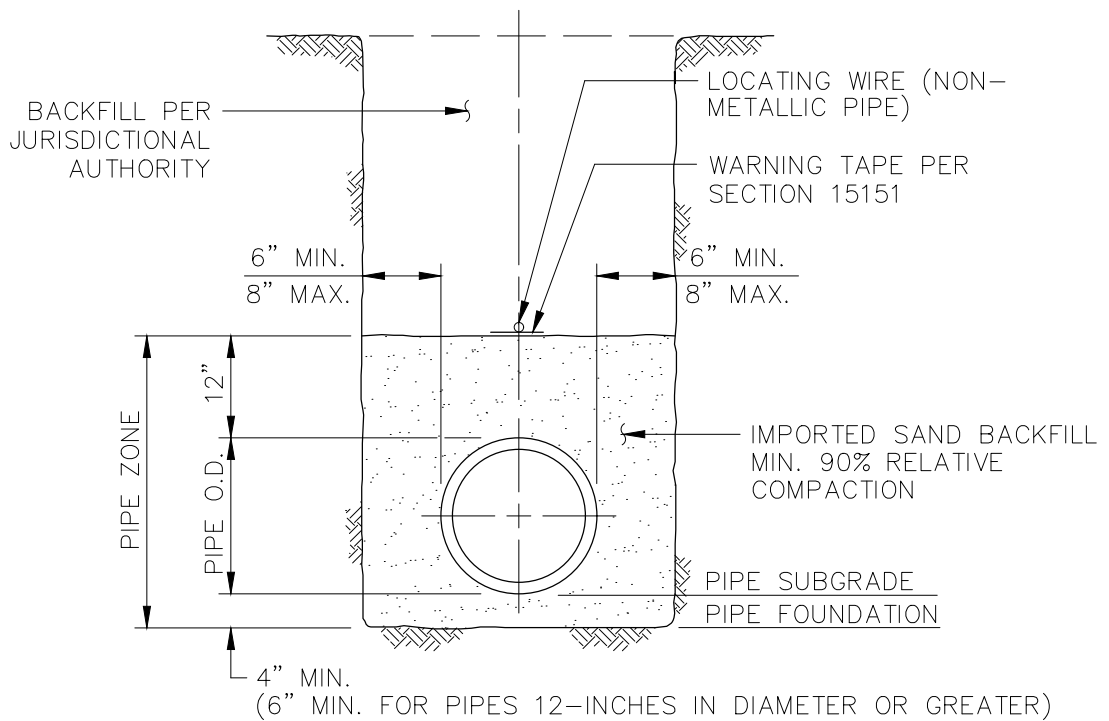

TYPICAL BEDDING

NOTE:

OVEREXCAVATE TO REMOVE UNSUITABLE SOIL IF NECESSARY AND REESTABLISH GRADE WITH 3/4" CRUSHED ROCK. DISTRICT TO DETERMINE DEPTH AND WIDTH OF REMOVAL.

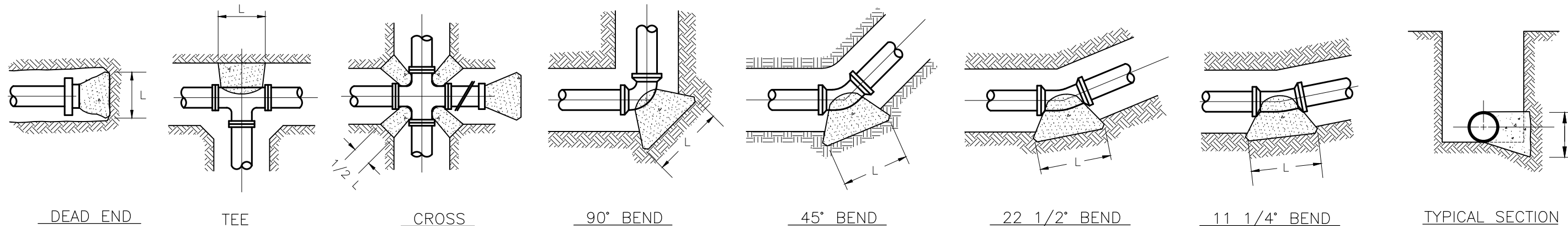

GENERAL NOTES

1. PROVIDE CLASS B CONCRETE. PRESSURE TEST SHALL BE PERFORMED IN ACCORD WITH CONCRETE CURING REQUIREMENTS.
2. THRUST BLOCKS SHALL BEAR AGAINST UNDISTURBED SOIL.
3. BEARING AREAS 'L' X 'H' ARE COMPUTED FOR TEST PRESSURES OF 225 PSI IN MAINS LAID IN A COHESIONLESS SOIL (C=0) WITH INTERNAL ANGLE OF FRICTION OF 37°, A UNIT WEIGHT OF 110 PCF, AND AT LEAST 36" OF COVER.
4. BEARING AREAS 'L' X 'H' SHALL BE APPROVED BY THE DISTRICT WHERE MAINS: (A) BEAR AGAINST WEAKER SOIL THAN DESCRIBED ABOVE, (B) HAVE LESS THAN 36" OF COVER, OR (C) ARE NOT REPRESENTED BY A FITTING OR SIZE SHOWN HEREON.
5. 'L' IS APPROXIMATELY EQUAL TO 'H' FOR SMALLER THRUST BLOCKS. 'L' IS GREATER THAN H FOR LARGER THRUST BLOCKS. 'H' SHALL NOT EXCEED TRENCH HEIGHT.
6. REBAR AT VALVES AND VERTICAL BENDS SHALL BE EPOXY COATED.

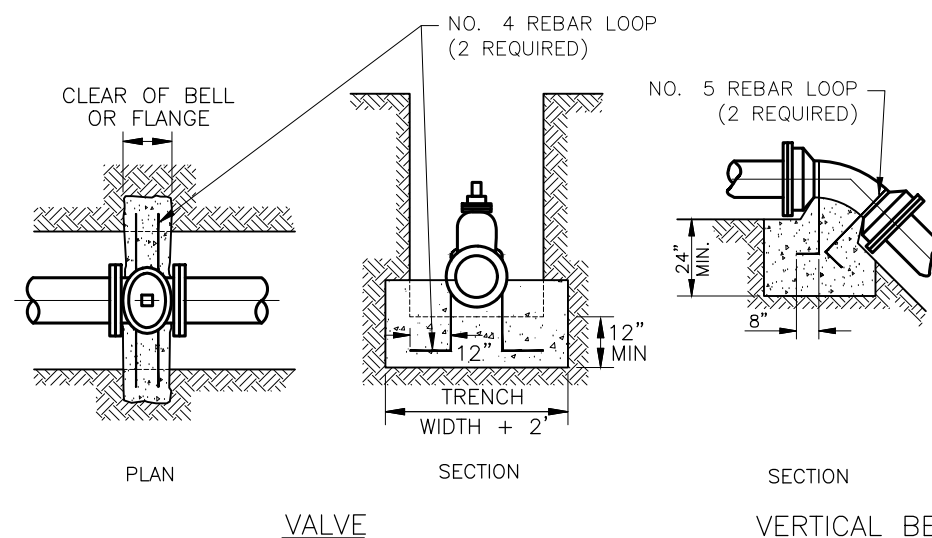

PIPE SIZE (IN)	CONCRETE VOLUME (CUBIC YARDS)		
	45°	22.5°	11.25°
4	0.7	0.4	0.2
6	1.6	0.8	0.4
8	2.8	1.5	0.7
10	4.4	2.2	1.1
12	6.4	3.2	1.6
16	11.4	5.6	2.8

THRUST BLOCK SIZES

Bearing Area (sq-ft) and Thrust Block Dimensions (in)

PIPE SIZE (inches)	DEAD END			TEE OR CROSS			90° BEND			45° BEND			22.5° BEND			11.25° BEND		
	Area (sq-ft)	L (in)	H (in)	Area (sq-ft)	L (in)	H (in)	Area (sq-ft)	L (in)	H (in)	Area (sq-ft)	L (in)	H (in)	Area (sq-ft)	L (in)	H (in)	Area (sq-ft)	L (in)	H (in)
4	2.0	17	17	2.0	17	17	2.9	21	21	1.9	17	17	1.0	12	12	0.4	8	8
6	4.3	25	25	4.3	25	25	6.0	30	30	4.3	25	25	2.2	18	18	1.0	12	12
8	7.4	36	30	7.4	36	30	10.5	42	36	7.6	37	30	3.9	24	24	1.9	17	17
10	12.1	42	42	12.1	42	42	17.1	59	42	10.3	42	36	5.5	30	27	3.1	22	22
12	17.2	52	48	17.2	52	48	24.3	73	48	17.2	52	48	8.7	42	30	4.3	26	24
16	26.7	72	54	26.7	72	54	37.8	101	54	30.6	82	54	15.6	54	42	7.8	38	30

STEEL CASING DIMENSION TABLE

PIPE SIZE	MIN. CASING SIZE	MIN. WALL THICKNESS
6"	16" I.D.	1/4"
8"	18" I.D.	1/4"
10"	21" I.D.	5/16"
12"	24" O.D.	5/16"
16"	30" O.D.	3/8"

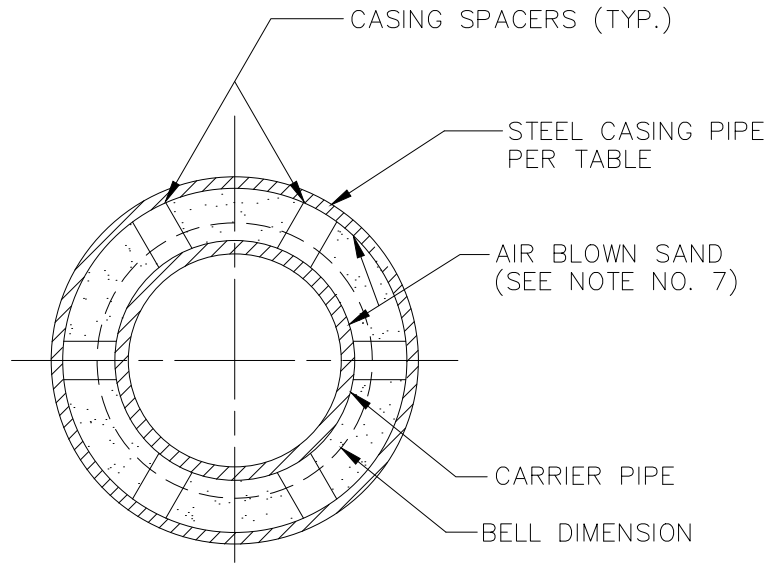

CROSS SECTION

NOTES:

1. CASING SHALL BE INSTALLED BY THE BORE, JACK AND/OR TUNNEL METHOD.
2. CARRIER PIPE SHALL BE AIR TESTED PRIOR TO FILLING CASING.
3. UPSTREAM AND DOWNSTREAM ELEVATIONS TO BE VERIFIED PRIOR TO FILLING CASING.
4. ALL CASING SECTIONS TO BE JOINED BY CONTINUOUS WELD.
5. CASING SHALL BE SEALED WITH AN END SEAL ON EACH END.
6. ALL PIPE JOINTS WITHIN THE CASING SHALL BE RESTRAINED.
7. UNLESS OTHERWISE NOTED ON THE PLANS, THE ANNULAR SPACE WITHIN THE CASING SHALL BE FILLED WITH AIR BLOWN SAND.

GENERAL NOTE

THE STATE WATER RESOURCES CONTROL BOARD (SWRCB) AND STATE OF CALIFORNIA REGULATIONS (TITLE 22, CHAPTER 16 SECTION 64572) SHALL BE FOLLOWED WHEN DESIGNING AND CONSTRUCTING NEW POTABLE WATER, RECYCLED WATER, AND SEWER MAINS. WHEN SWRCB AND DISTRICT STANDARDS CONFLICT, THE MOST STRINGENT REQUIREMENT SHALL APPLY UNLESS OTHERWISE APPROVED BY THE DISTRICT.

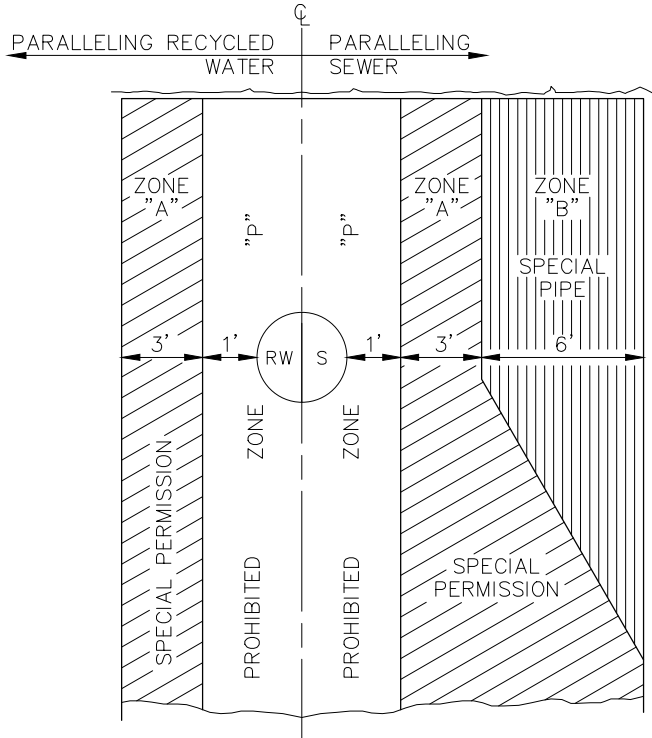

BASIC SEPARATION STANDARDS

1. PARALLEL CONSTRUCTION: THE HORIZONTAL DISTANCE BETWEEN PRESSURE POTABLE WATER AND THE FOLLOWING MAINS SHALL BE AT LEAST:
 - a) TERTIARY-TREATED RECYCLED WATER: 4'
 - b) SEWER: 10'
2. PERPENDICULAR CONSTRUCTION (CROSSING): PRESSURE POTABLE WATER MAINS SHALL BE AT LEAST ONE FOOT ABOVE SEWER AND RECYCLED WATER LINES WHERE THESE LINES MUST CROSS.

SPECIAL CONSTRUCTION REQUIRED FOR WATER

ZONE

- "A" NO POTABLE WATER LINES PARALLEL TO RECYCLED WATER OR SEWER LINES SHALL BE PERMITTED IN THIS ZONE WITHOUT APPROVAL FROM COUNTY AND STATE BOARD'S DIVISION OF DRINKING WATER AND THE DISTRICT. IF APPROVED, ZONE 'B' PIPE MATERIALS ARE REQUIRED UNLESS OTHERWISE REQUIRED.
- "B" THE POTABLE WATER MAIN SHALL BE CONSTRUCTED OF:
1. CLASS 200 PRESSURE RATED PLASTIC WATER PIPE (DR 14 PER AWWA C900) OR EQUIVALENT.
 2. DUCTILE IRON PIPE.
 3. HDPE PIPE WITH BUTT-FUSED JOINTS
 4. CEMENT-MORTAR LINED AND COATED 1/4" THICK STEEL PIPE WITH WELDED JOINTS.
- "C" THE POTABLE WATER MAIN SHALL HAVE NO JOINTS IN ZONE "C" AND BE CONSTRUCTED OF:
1. DUCTILE IRON PIPE.
 2. HDPE PIPE WITH BUTT-FUSED JOINTS
 3. CEMENT-MORTAR LINED AND COATED 1/4" THICK STEEL PIPE WITH WELDED JOINTS.
- "D" THE POTABLE WATER MAIN SHALL HAVE NO JOINTS WITHIN 8- FEET FROM EITHER SIDE OF THE RECYCLED OR SEWER LINE AND SHALL BE CONSTRUCTED OF:
1. CLASS 200 PRESSURE RATED PLASTIC WATER PIPE (DR 14 PER AWWA C900) OR EQUIVALENT.
 2. DUCTILE IRON PIPE.
 3. HDPE PIPE WITH BUTT-FUSED JOINTS
 4. CEMENT-MORTAR LINED AND COATED 1/4" THICK STEEL PIPE WITH WELDED JOINTS.
- "P" NO WATER MAIN SHALL BE CONSTRUCTED PER SECTION 64630 (2) CALIFORNIA ADMINISTRATIVE CODE, TITLE 22.

POTABLE WATER MAIN PARALLEL TO SEWER/RECYCLED WATER MAINS

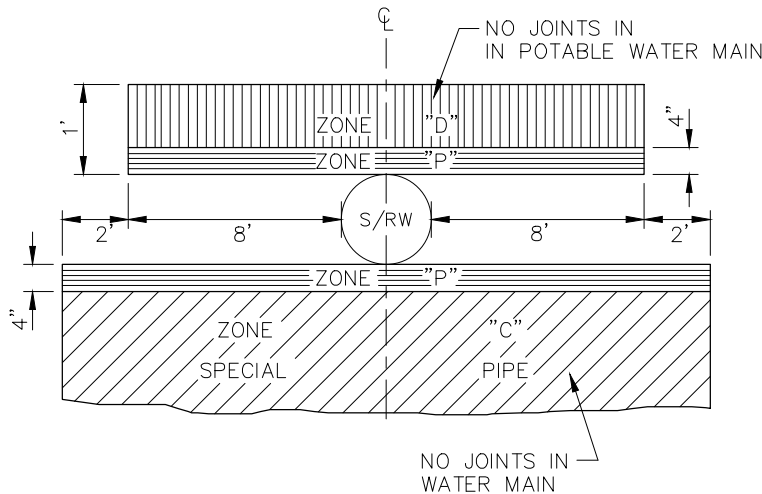

POTABLE WATER MAIN CROSSING SEWER/RECYCLED WATER MAINS

S = SEWER MAIN
RW = RECYCLED WATER MAIN

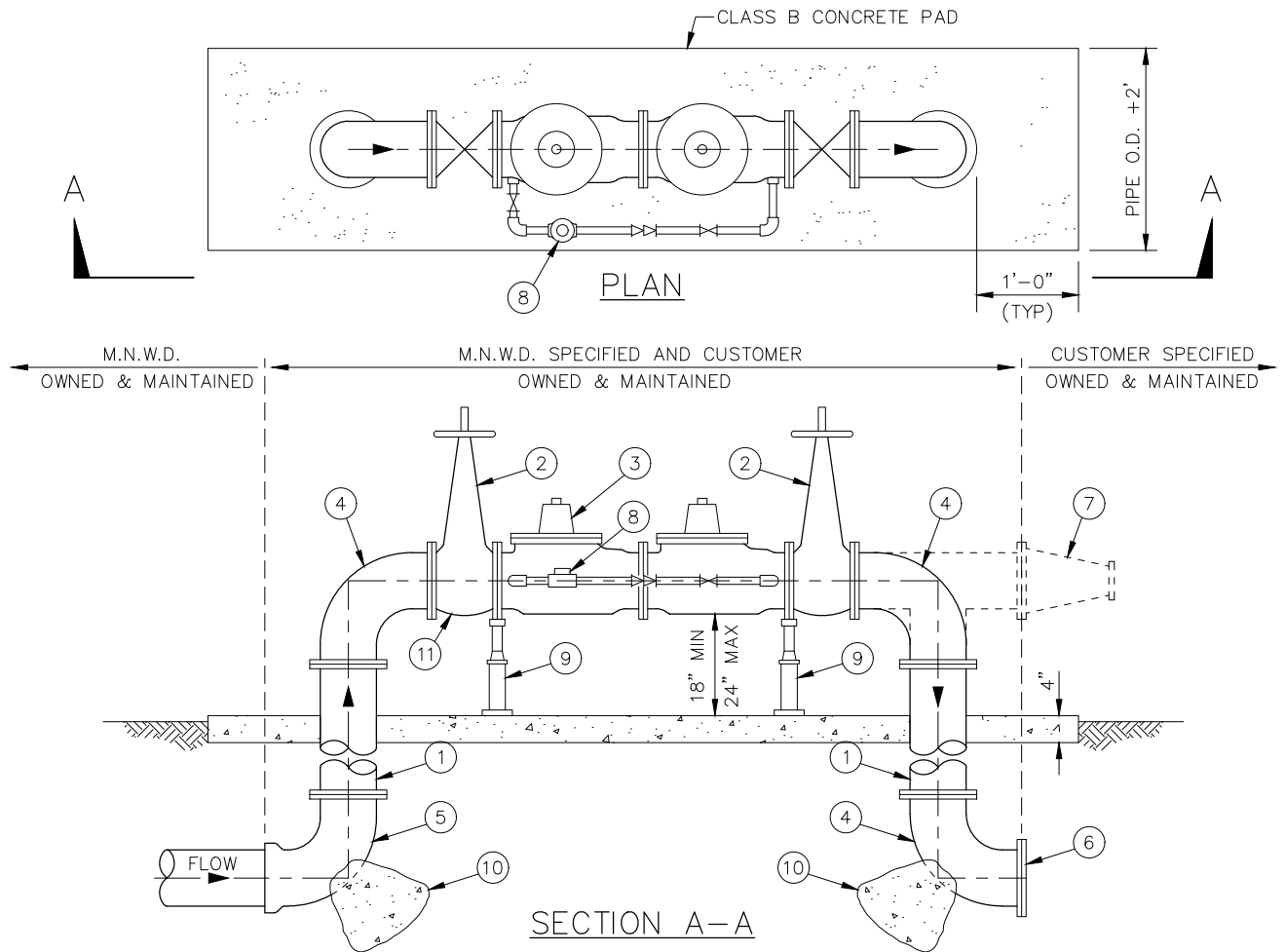

CONSTRUCTION ITEMS

- | | |
|--|--|
| <ul style="list-style-type: none"> ① DUCTILE IRON FLANGED SPOOL, CLASS 53, 175 PSI RATING MIN. ② RESILIENT WEDGE GATE VALVE OS & Y ③ U.S.C./F.C.C. & H.R. INSTITUTE AND STATE WATER RESOURCE CONTROL BOARD DOUBLE CHECK DETECTOR ASSEMBLY, OR AS OTHERWISE REQUIRED BY THE DISTRICT. ④ DUCTILE IRON FLANGED 90° ELBOW ⑤ DUCTILE IRON PUSH-ON x FLANGE 90° ELBOW ⑥ BLIND FLANGE | <ul style="list-style-type: none"> ⑦ OPTIONAL TEE, AND 2 1/2 SIAMESE FIRE DEPT. CONNECTION ⑧ DISTRICT APPROVED 3/4-INCH BYPASS METER (MNWD MAINTAINED) ⑨ ADJUSTABLE PIPE SUPPORT, GRINNELL NO. 264 OR APPROVED EQUAL ⑩ THRUST BLOCK PER STD. DWG. W-12 ⑪ NOTIFY DISTRICT INSPECTOR AT LEAST 72 HOURS PRIOR TO ANY WORK THAT IS TO OCCUR DOWNSTREAM OF THE FIRST ISOLATION VALVE. (NOT SHOWN ON DRAWING) |
|--|--|

NOTES

1. ALL UNITS MUST BE ON THE LATEST APPROVED LIST OF BACKFLOW PREVENTION ASSEMBLIES FROM THE U.S.C./F.C.C.C. & H.R. INSTITUTE AND COMPLY WITH THE CALIFORNIA STATE WATER RESOURCES CONTROL BOARD.
2. INSTALLATION SHALL COMPLY WITH THE LATEST PLUMBING CODES AND APPLICABLE LOCAL AGENCY REQUIREMENTS.
3. UPON COMPLETION OF THE INSTALLATION OF THE DEVICE, A TEST SHALL BE PERFORMED AND A CERTIFICATE OF ADEQUACY AND OPERATIONAL COMPLIANCE SHALL BE FURNISHED TO MNWD.
4. FIRE SERVICE DETECTOR CHECK AND BACKFLOW PREVENTION ASSEMBLY SHALL BE INSTALLED IN A PUBLIC RIGHT-OF-WAY OR AN EASEMENT DEDICATED TO THE DISTRICT.
5. ALL ABOVE GROUND PIPING SHALL BE PRIMED AND PAINTED PER SECTION 09900.
6. MAINTENANCE OF THE BACKFLOW ASSEMBLY, PIPING, FITTINGS, CONNECTIONS AND VALVES SHALL BE THE RESPONSIBILITY OF THE CUSTOMER INCLUDING POINT OF CONNECTION AT CHANGE OF OWNERSHIP.
7. BOLTS LOCATED BELOW GRADE SHALL BE TYPE 316 STAINLESS STEEL.
8. WRAP & GREASE BURIED PORTIONS OF PIPE AND APPURTENANCES WITH UPC 10 MIL MIN PIPE WRAP.

MOULTON NIGUEL WATER DISTRICT	W-15 AUGUST 2024
ABOVE GROUND PRIVATE FIRE SERVICE	

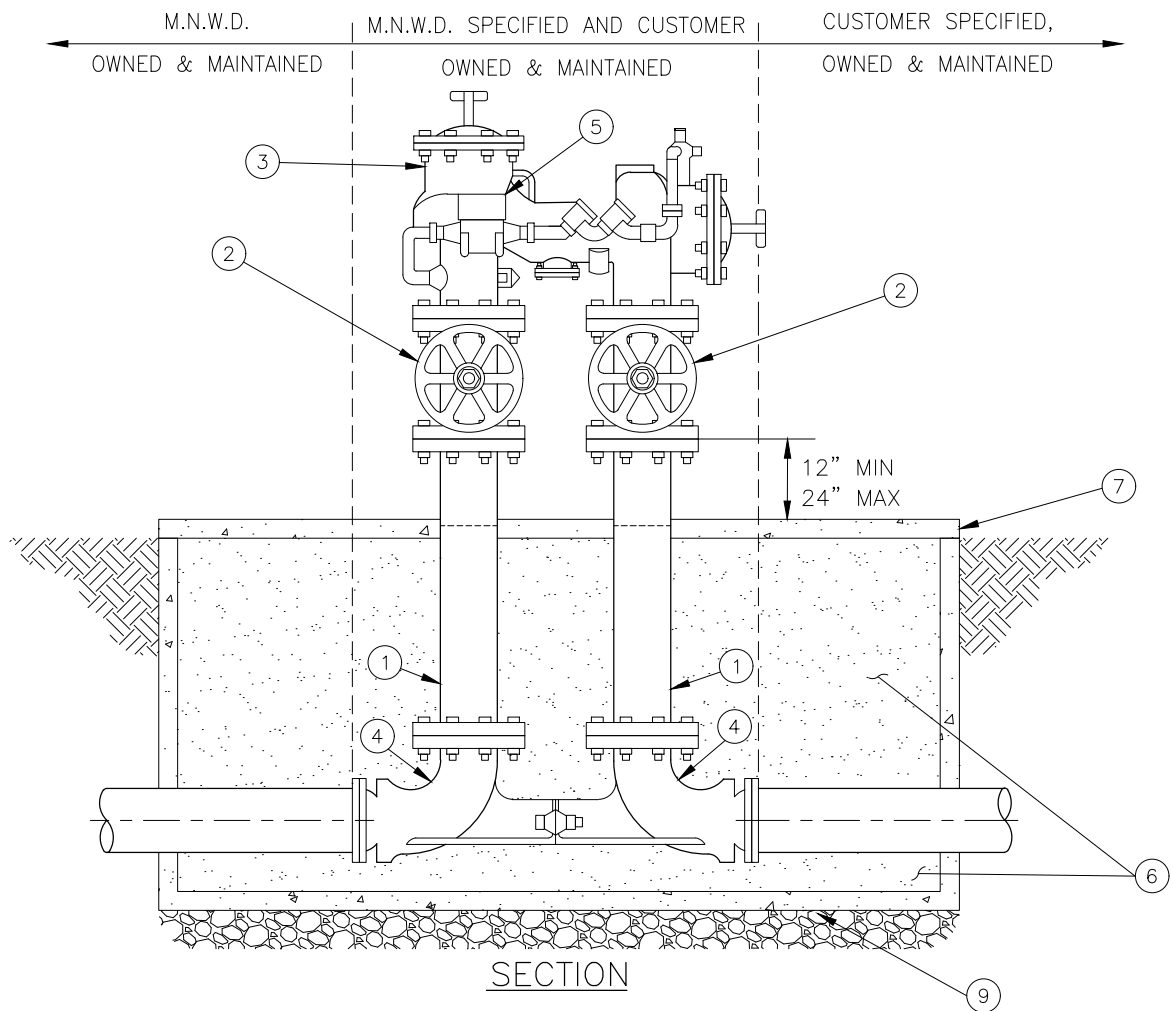

SECTION

CONSTRUCTION ITEMS

- | | |
|--|---|
| <p>① DUCTILE IRON FLANGED SPOOL, SINGLE PIECE, 175 PSI RATING MIN, SINGLE SPOOL FROM FLANGE TO FLANGE</p> <p>② RESILIENT WEDGE GATE VALVE OS & Y</p> <p>③ U.S.C./F.C.C. & H.R. INSTITUTE AND STATE WATER RESOURCE CONTROL BOARD DOUBLE CHECK DETECTOR ASSEMBLY, OR AS OTHERWISE REQUIRED BY THE DISTRICT.</p> <p>④ DUCTILE IRON FLANGED ELBOW WITH VALVE SETTER, 175 PSI RATING MIN.</p> | <p>⑤ DISTRICT APPROVED BYPASS METER (MNWD MAINTAINED)</p> <p>⑥ "0" SACK SLURRY TO TOP OF VAULT</p> <p>⑦ 4" CONCRETE PAD</p> <p>⑧ NOTIFY DISTRICT INSPECTOR AT LEAST 72 HOURS PRIOR TO ANY WORK THAT IS TO OCCUR DOWNSTREAM OF THE FIRST ISOLATION VALVE. (NOT SHOWN ON DRAWING)</p> <p>⑨ CORE FOUR (4) 1" DIAMETER HOLES THROUGH THE BOTTOM OF THE EXISTING CONCRETE VAULT FLOOR.</p> |
|--|---|

NOTES

1. ALL UNITS MUST BE ON THE LATEST APPROVED LIST OF BACKFLOW PREVENTION ASSEMBLIES FROM THE U.S.C. / F.C.C.C. & H.R. INSTITUTE AND COMPLY WITH THE CALIFORNIA STATE WATER RESOURCES CONTROL BOARD.
2. INSTALLATION SHALL COMPLY WITH THE LATEST PLUMBING CODES AND APPLICABLE LOCAL AGENCY REQUIREMENTS.
3. UPON COMPLETION OF THE INSTALLATION OF THE BACKFLOW ASSEMBLY, A TEST SHALL BE PERFORMED AND A CERTIFICATE OF ADEQUACY AND OPERATIONAL COMPLIANCE SHALL BE FURNISHED TO M.N.W.D.
4. FIRE SERVICE DETECTOR CHECK AND BACKFLOW PREVENTION ASSEMBLY SHALL BE INSTALLED IN A PUBLIC RIGHT-OF-WAY OR AN EASEMENT DEDICATED TO THE DISTRICT.
5. ALL ABOVE GROUND PIPING SHALL BE PRIMED AND PAINTED PER SECTION 09900.
6. MAINTENANCE OF THE BACKFLOW ASSEMBLY, PIPING, FITTINGS, CONNECTIONS AND VALVES SHALL BE THE RESPONSIBILITY OF THE CUSTOMER INCLUDING POINT OF CONNECTION AT CHANGE OF OWNERSHIP.
7. BOLTS LOCATED BELOW GRADE SHALL BE TYPE 316 STAINLESS STEEL.
8. INSTALL CLASS B CONCRETE SLAB UNDER ASSEMBLY, LENGTH = ASSEMBLY LENGTH +12" EACH SIDE, WIDTH = PIPE DIAMETER +12" EACH SIDE, THICKNESS = 4".
9. WRAP & GREASE BURIED PORTIONS OF PIPE AND APPURTENANCES WITH UPC 10 MIL MIN PIPE WRAP.

MOULTON NIGUEL WATER DISTRICT

CONVERSION FROM BELOW GROUND TO
ABOVE GROUND PRIVATE FIRE SERVICE

W-16
AUGUST 2024

NOTES

1. ALL UNITS MUST BE ON THE LATEST APPROVED LIST OF BACKFLOW PREVENTION ASSEMBLIES FROM THE U.S.C./F.C.C.C. & H.R. INSTITUTE AND COMPLY WITH THE CALIFORNIA STATE WATER RESOURCES CONTROL BOARD.
2. ATTACH BLUE POTABLE WATER IDENTIFICATION TAGS AS DIRECTED ON POTABLE SYSTEMS USING METALLIC WIRE (NO PLASTIC ZIPS).
3. ATTACH GREEN POTABLE IRRIGATION IDENTIFICATION TAGS AS DIRECTED ON POTABLE IRRIGATION SYSTEMS USING METALLIC WIRE (NO PLASTIC ZIPS).
4. ALL BACKFLOW PREVENTION ASSEMBLIES FOR METER PROTECTION SHALL BE INSTALLED DIRECTLY OUTSIDE OF THE WATER METER BOX WITH NO WATER USE CONNECTIONS BETWEEN THE WATER METER AND THE BACKFLOW PREVENTION ASSEMBLY.
5. IF APPROVED BY DISTRICT, A DOUBLE CHECK BACKFLOW PREVENTION ASSEMBLY MAY BE USED FOR METER PROTECTION AT SINGLE FAMILY RESIDENTIAL PREMISES WITH LOW HAZARD FIRE SPRINKLER SYSTEMS.

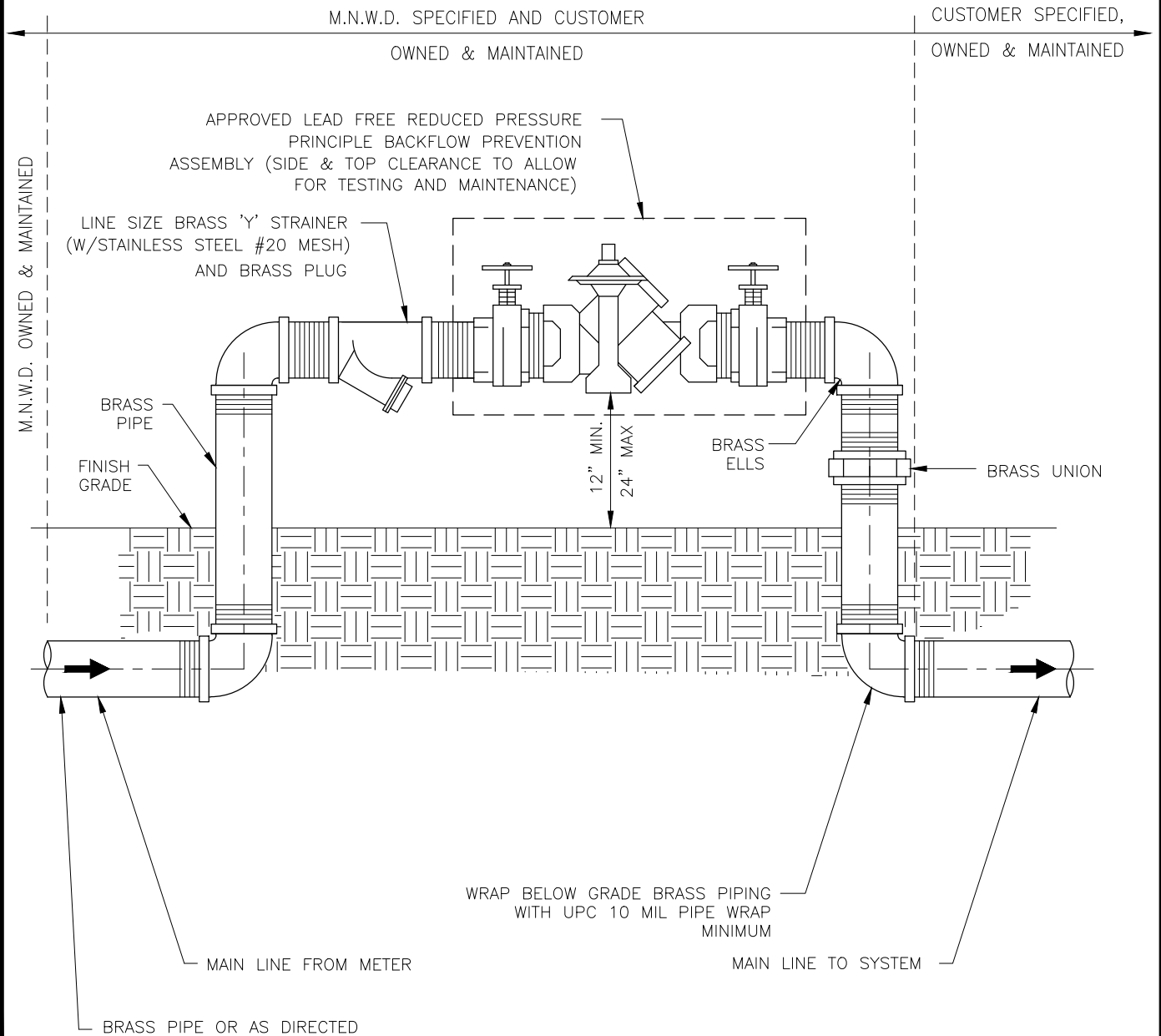

CONSTRUCTION ITEMS

- ① N.R.S. VALVE
- ② APPROVED REDUCED PRESSURE PRINCIPLE BACKFLOW PREVENTION ASSEMBLY
- ③ DIFFERENTIAL PRESSURE RELIEF VALVE
- ④ ADJUSTABLE PIPE SUPPORT, GRINNELL NO. 264 OR APPROVED EQUAL
- ⑤ THRUST BLOCK PER STD. DWG. W-12

NOTES

- 1. ALL UNITS MUST BE ON THE LATEST APPROVED LIST OF BACKFLOW PREVENTION ASSEMBLIES FROM THE U.S.C./F.C.C.C. & H.R. INSTITUTE AND COMPLY WITH THE CALIFORNIA STATE WATER RESOURCES CONTROL BOARD.
- 2. BACKFLOW PREVENTION ASSEMBLY TO BE INSTALLED DIRECTLY DOWNSTREAM OF WATER METER
- 3. WYE STRAINER OPTIONAL

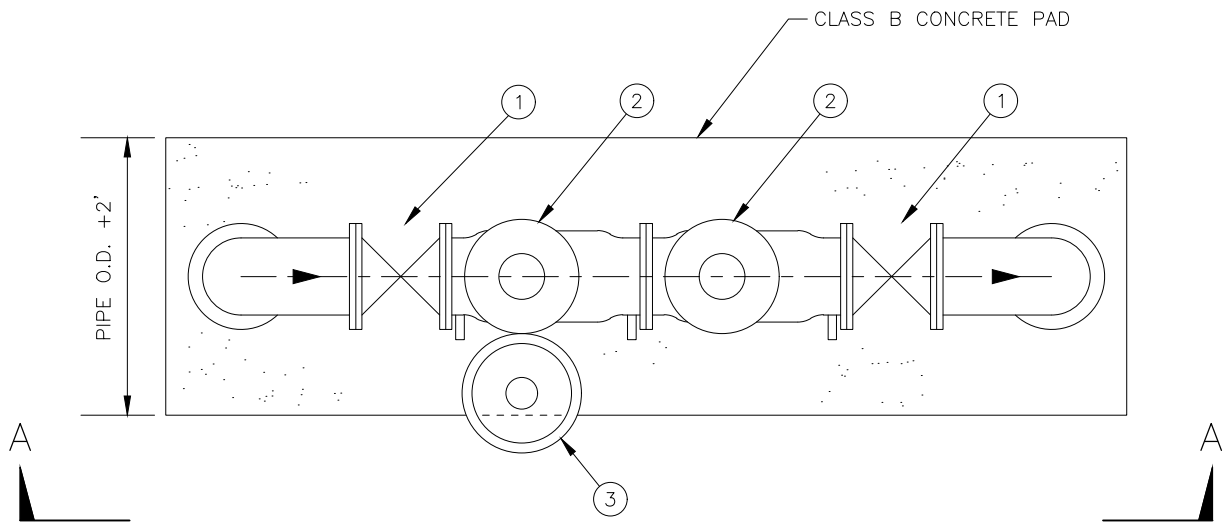

PLAN

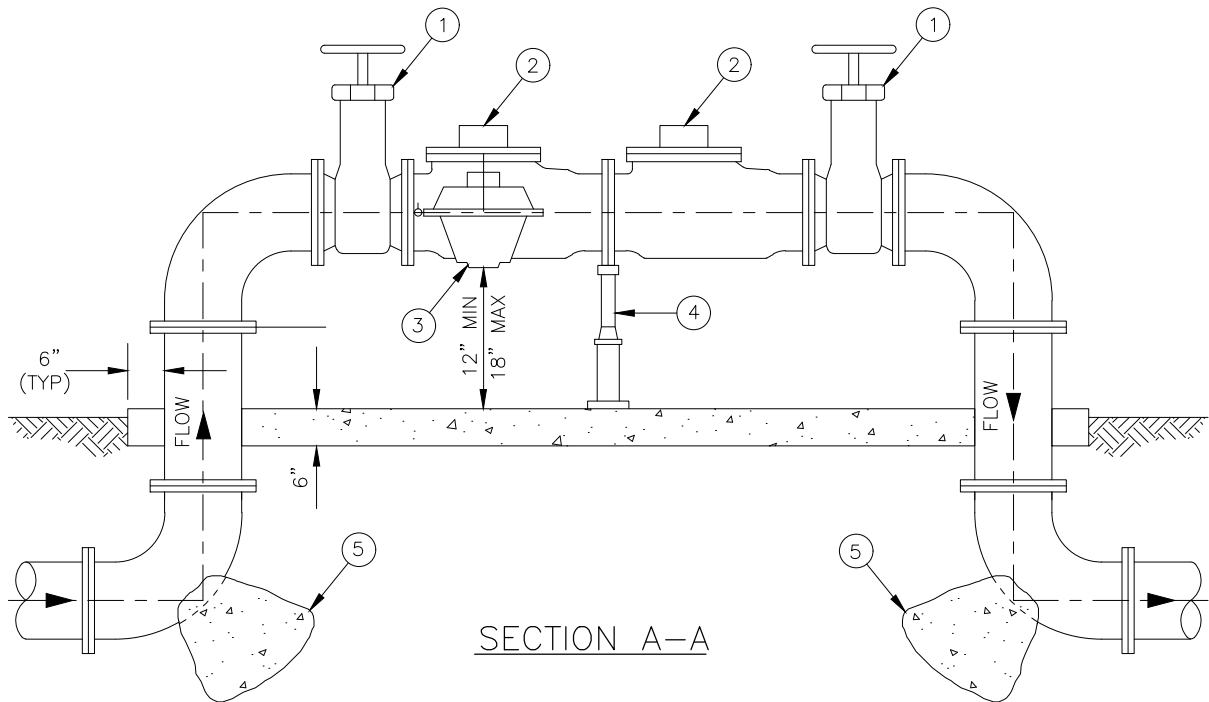

SECTION A-A

MOULTON NIGUEL WATER DISTRICT

BACKFLOW PREVENTION
ASSEMBLY 3" AND LARGER

W-18
AUGUST 2024

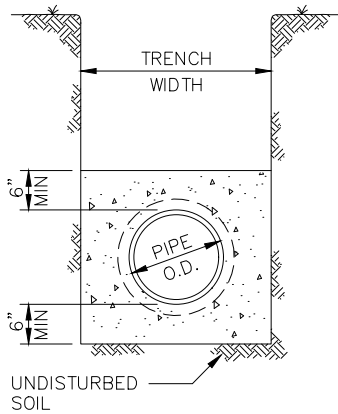

TYPE "A"

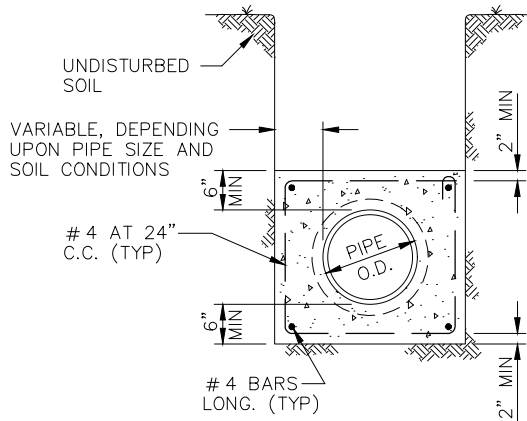

TYPE "B"

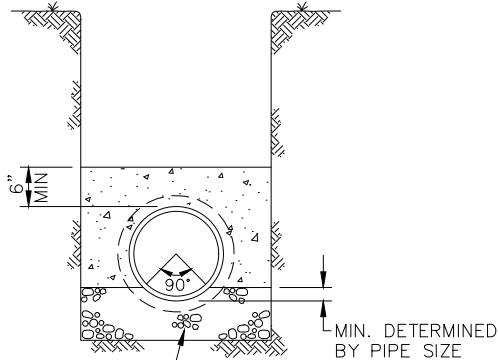

BEDDING, SEE STD. DWG. S-8

TYPE "C"

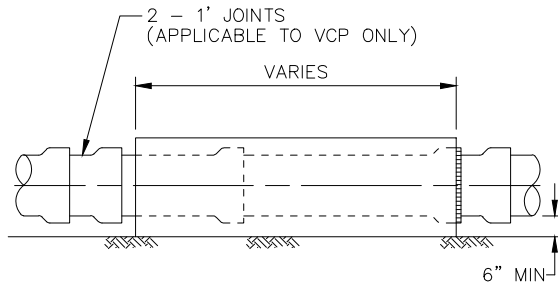

SECTION

NOTES:

1. ENCASUREMENT TO BE PLACED AGAINST UNDISTURBED NATURAL GROUND OR FILL COMPACTED TO 90% RELATIVE COMPACTION.
2. USE NO. 4 STEEL REINFORCING BARS.
3. TYPE OF CONCRETE ENCASUREMENT TO BE USED WILL BE SHOWN ON PLANS OR AS SPECIFIED BY INSPECTOR TO MEET UNFORESEEN FIELD CONDITIONS.
4. WHERE SLOPE TRENCHES ARE USED, WALLS WILL NOT BEGIN TO SLOPE CLOSER THAN 12" FROM THE TOP OF THE PIPE.
5. ENCASUREMENT CONCRETE TO BE CLASS "B".
6. CONTINUE D.I.P. POLY BAG ENCASUREMENT THROUGH CONCRETE.

CONCRETE ENCASUREMENT

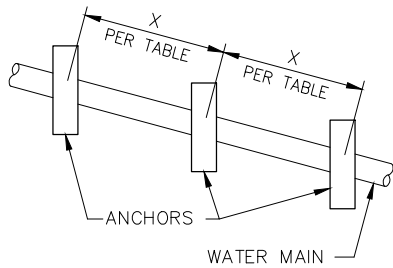

WATER MAIN

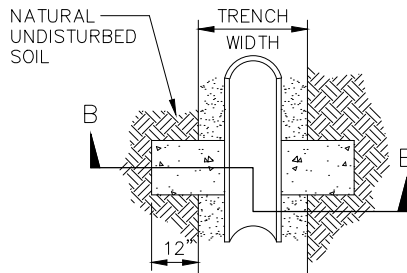

SECTION A-A

NOTES:

1. PIPE ANCHORS REQUIRED ON ALL SLOPES OF 20% OR GREATER.
2. ANCHOR SHALL EXTEND 12" INTO NATURAL UNDISTURBED SOIL.
3. CONCRETE SHALL BE CLASS "B".
4. ANCHORS FOR TRAPEZOIDAL TRENCH SECTIONS WILL CONFORM TO TRENCH CROSS SECTION AND EXTEND 12" INTO UNDISTURBED SOIL.
5. DO NOT EXTEND D.I.P. POLY BAG THRU ANCHORS - SEAL BAG TO PIPE ON EACH SIDE OF EACH ANCHOR.

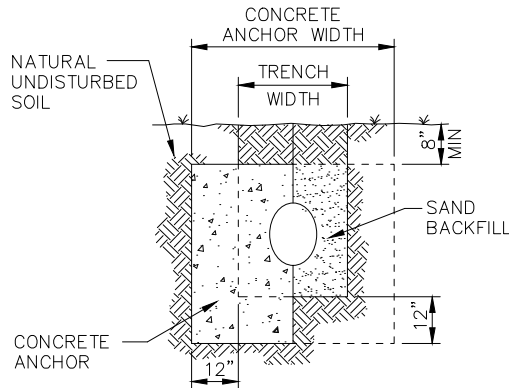
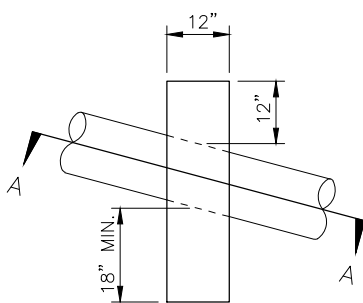

SECTION B-B

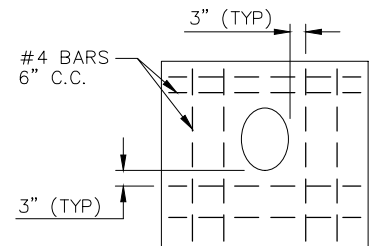

REINFORCING STEEL PATTERN

SLOPE ANCHORS

TABLE

PIPE SLOPE	X DISTANCE
20% TO 35%	36'
35% TO 50%	24'
> 50%	16'

MOULTON NIGUEL WATER DISTRICT

CONCRETE ENCASUREMENT AND SLOPE ANCHORS

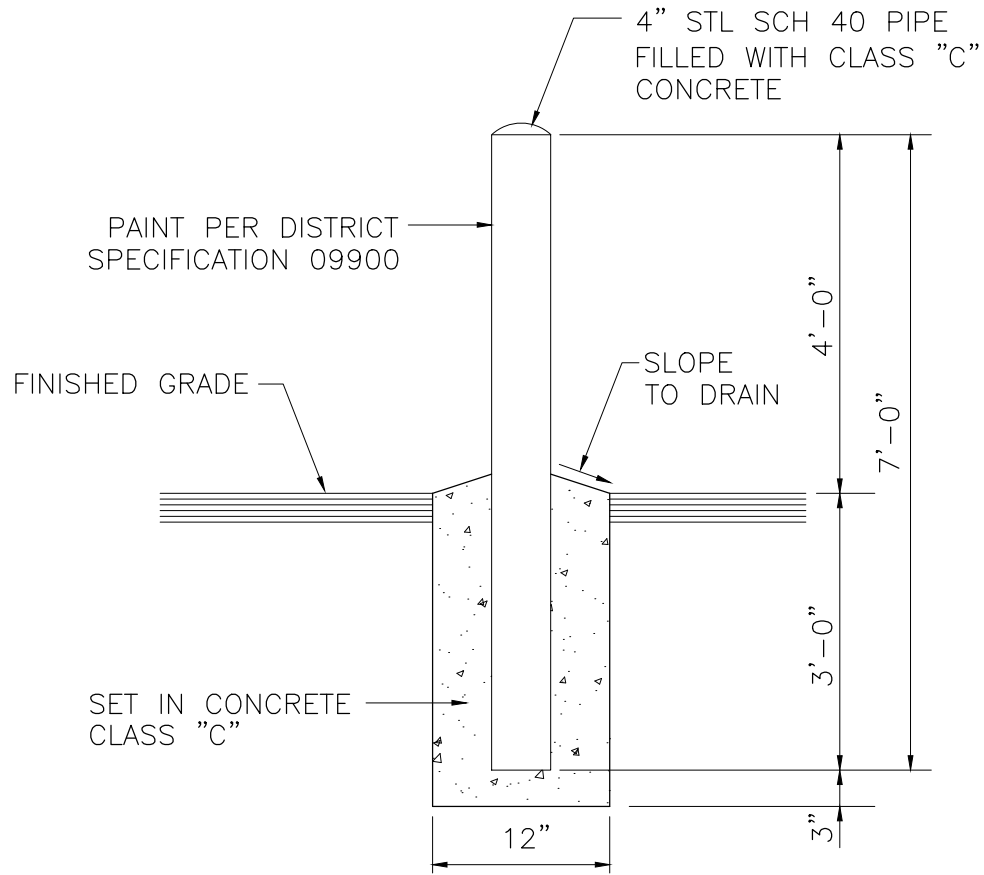

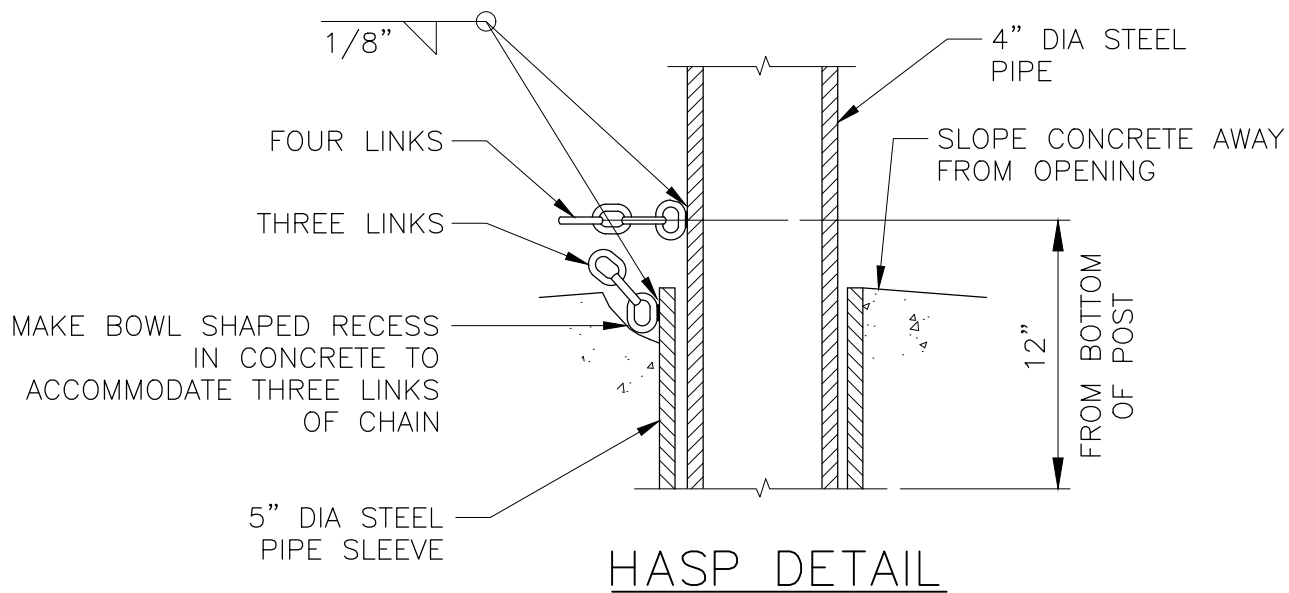
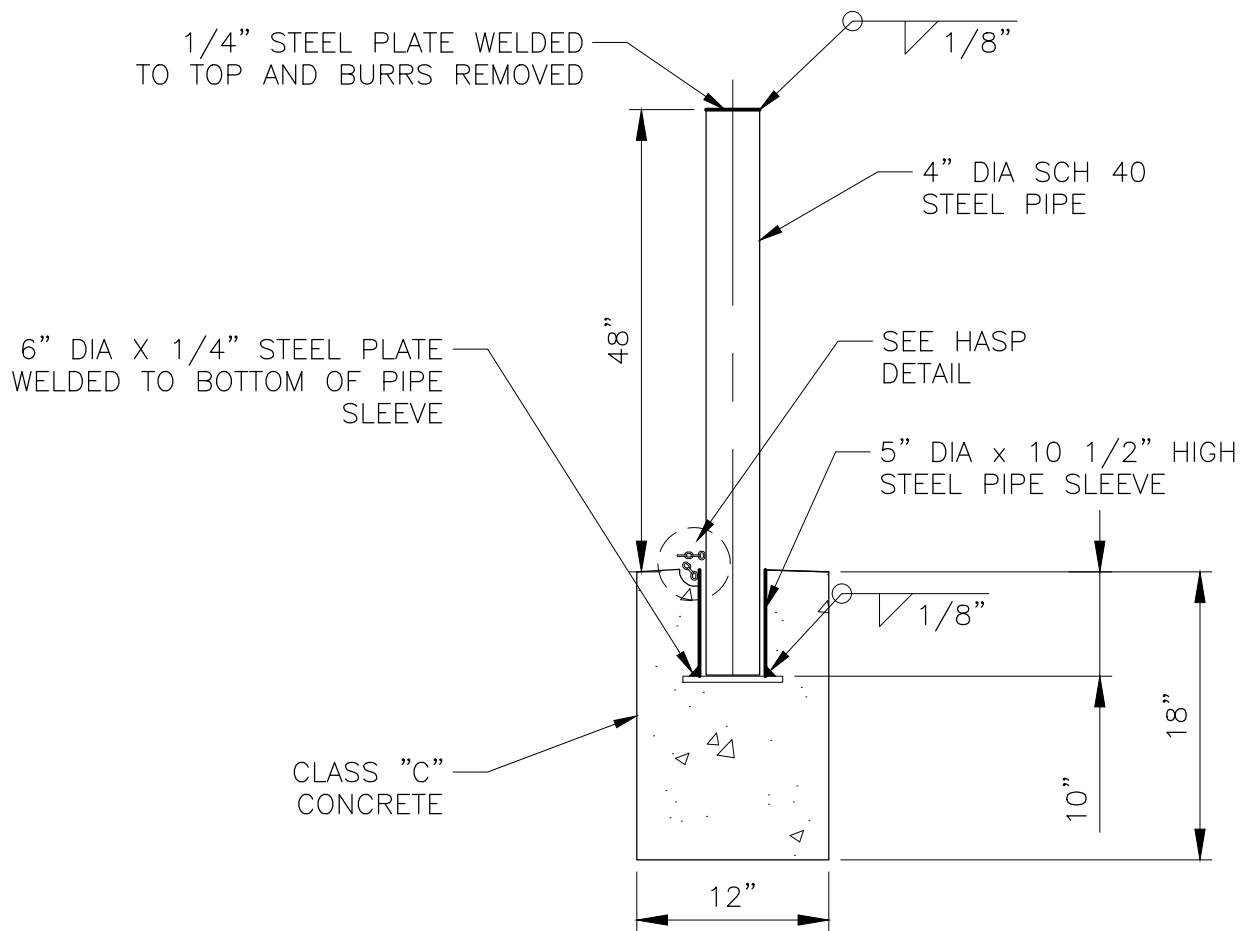

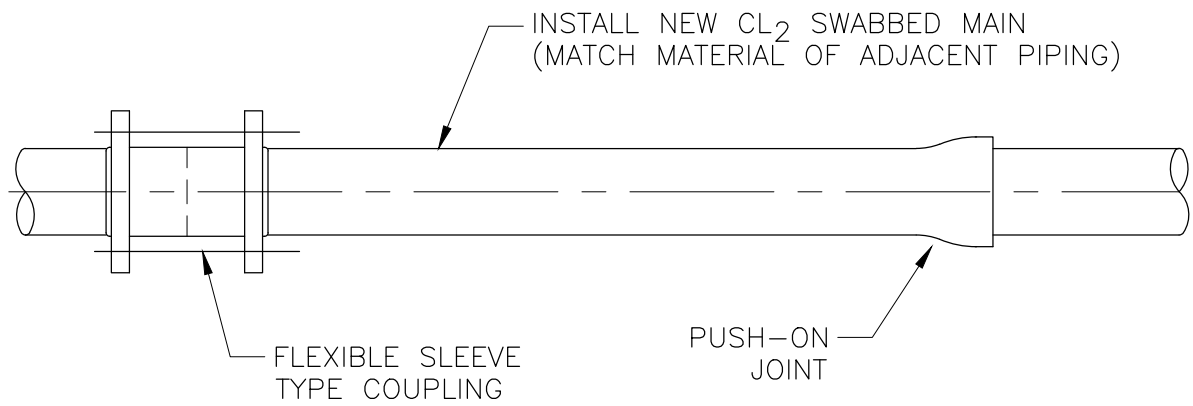
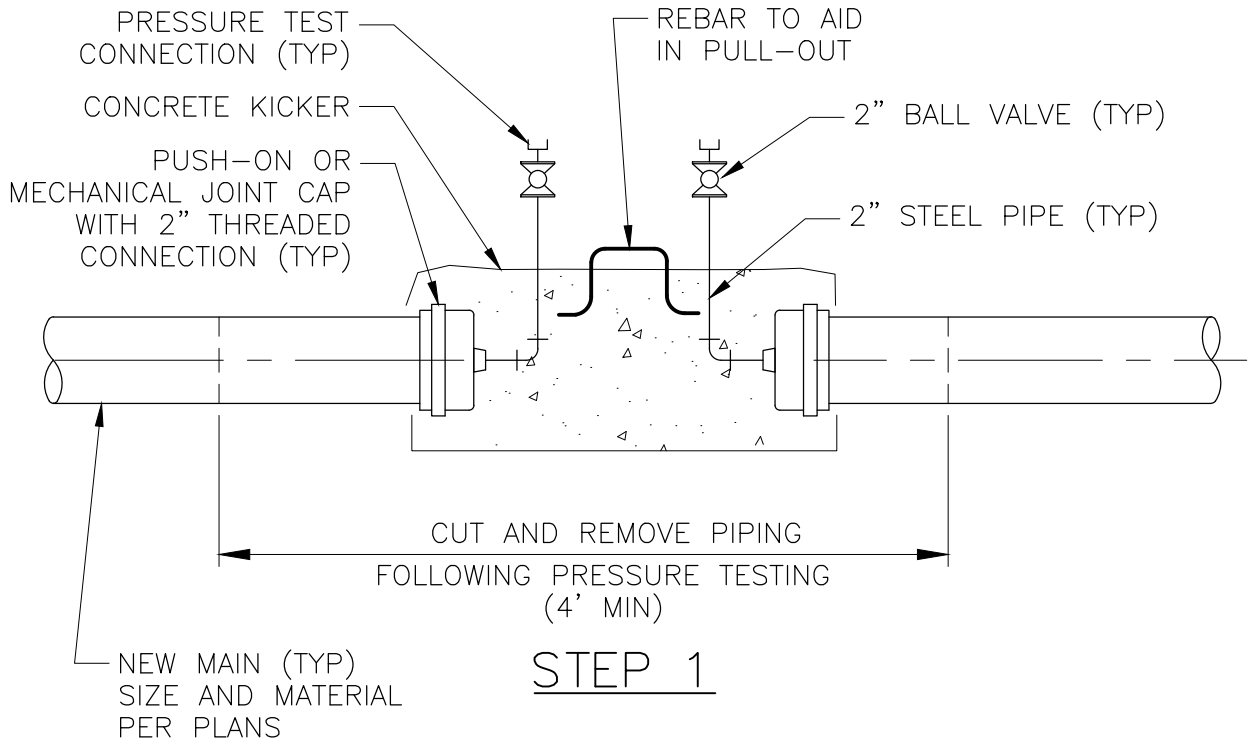

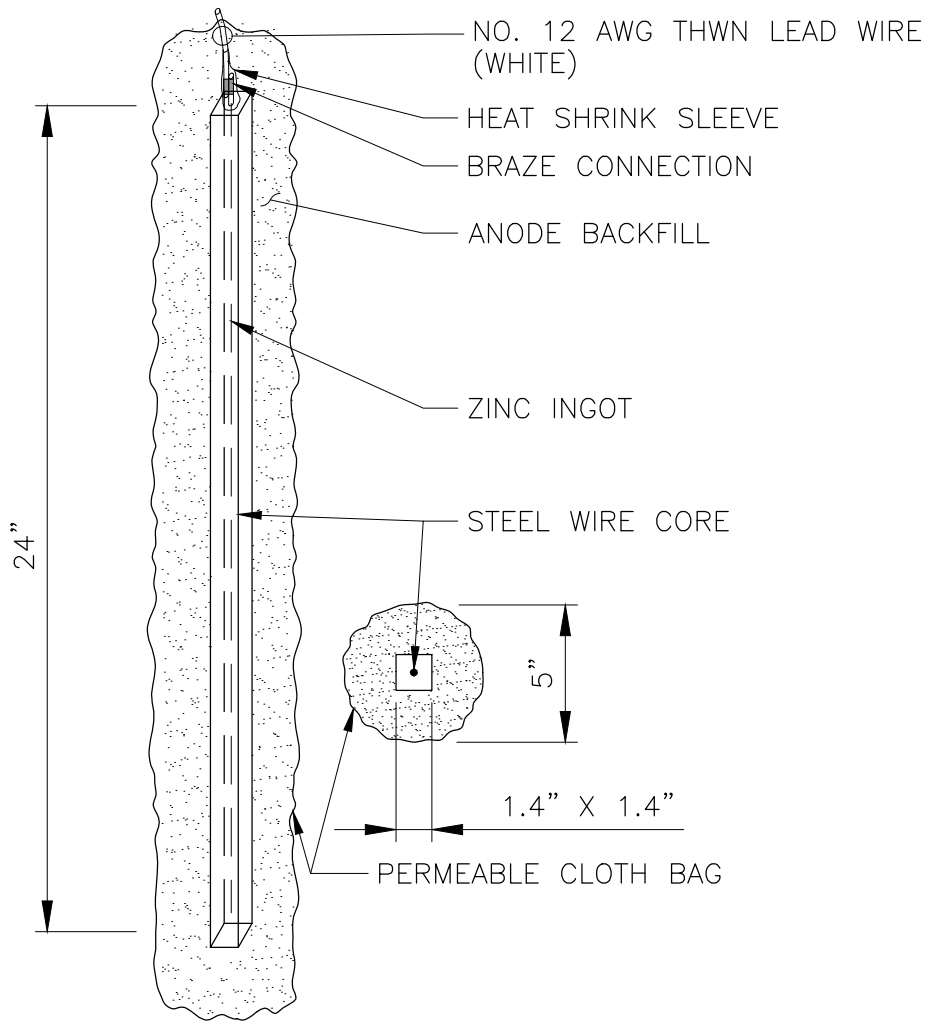

NOTE :

ANODE SOAKING REQUIREMENTS:
 PLACE ANODE IN HOLE OR TRENCH. ADD 5 GALLONS OF WATER AND ALLOW TO SOAK FOR 30 MIN. BACKFILL TO TOP OF ANODE. ADD AN ADDITIONAL 5 GALLONS OF WATER TO COMPLETELY SATURATE THE SOIL SURROUNDING ANODE. LET SOAK FOR 15 MIN. PRIOR TO BACKFILLING.

MOULTON NIGUEL WATER DISTRICT

ZINC ANODE FOR SERVICES
 AND AIR-VACS

W-23
 AUGUST 2024

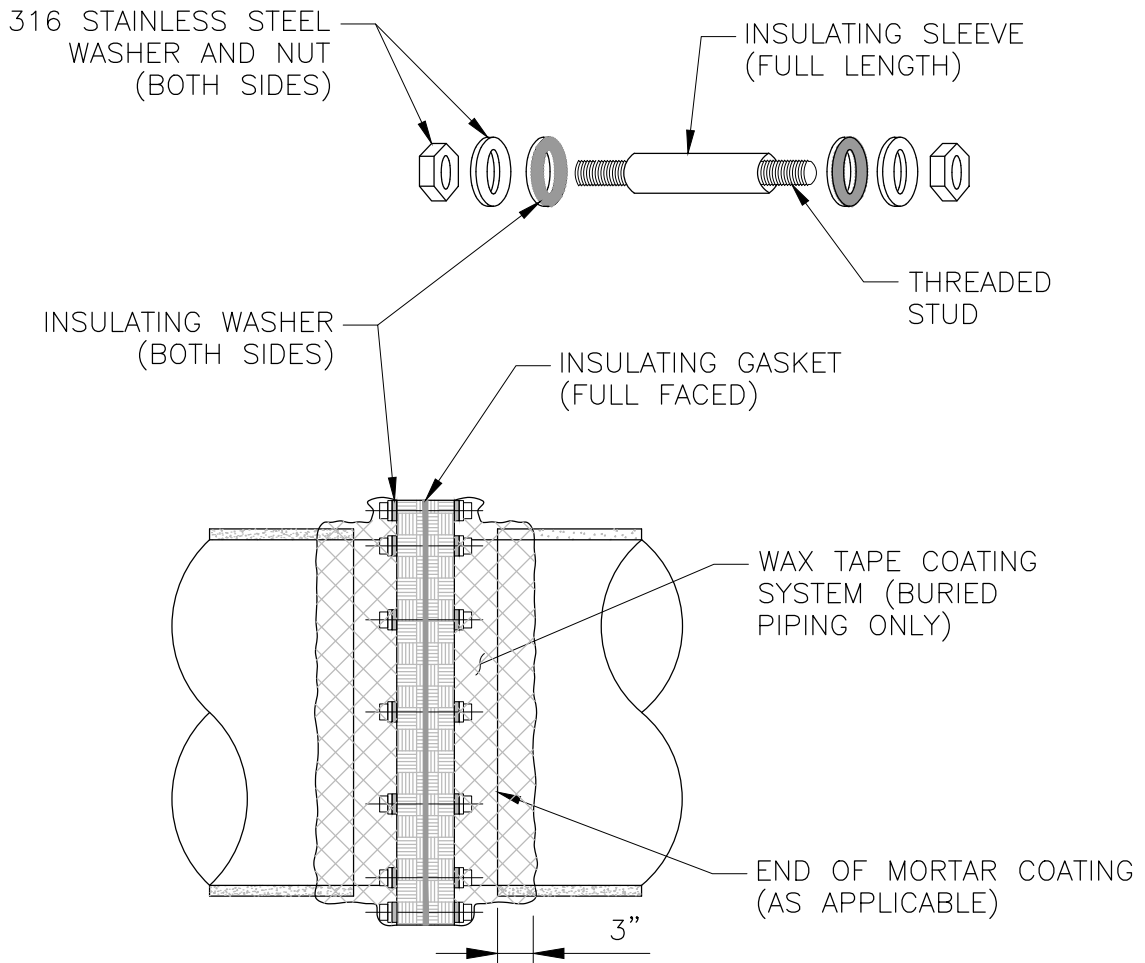

NOTES :

1. CARE SHALL BE TAKEN WHEN BACKFILLING TRENCH TO PREVENT DAMAGE TO WAX TAPE SYSTEM.
2. USE HALF-WIDTH SLEEVES AT THREADED FLANGE BOLTS (I.E. AT BUTTERFLY VALVE BONNET)
3. DO NOT PAINT OUTER SURFACE OF FLANGE WITH METALLIC PIGMENTED OR CONDUCTIVE PAINTS.

MOULTON NIGUEL WATER DISTRICT

ABOVE GROUND AND BURIED
INSULATING FLANGE

W-24
AUGUST 2024

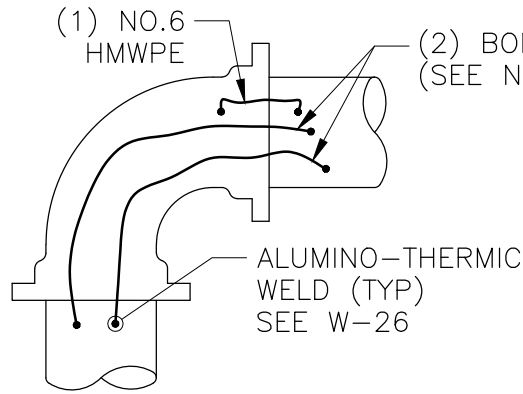

FITTING

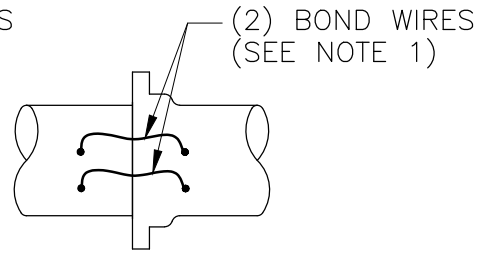

MECHANICAL
OR PUSH-ON
JOINT

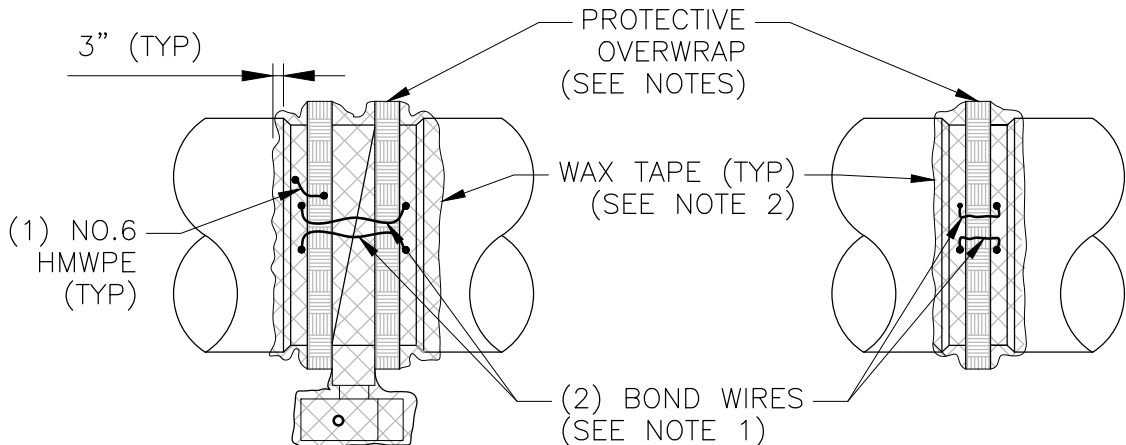

VALVE

FLANGE

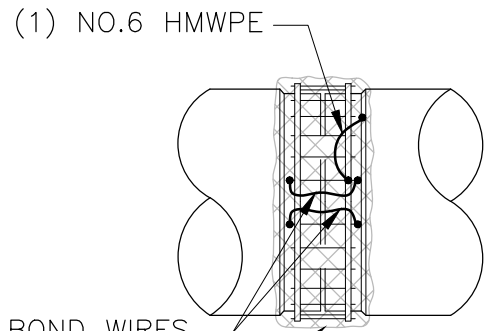

(2) BOND WIRES (SEE NOTE 1)
WAX TAPE (TYP) (SEE NOTE 2)

COUPLING

NOTES :

1. BOND WIRE SIZE:
- | PIPE DIA | SIZE |
|----------|-----------------|
| <14" | NO. 6 AWG HMWPE |
| <20" | NO. 4 AWG HMWPE |
| >20" | NO. 2 AWG HMWPE |

2. INSTALL BOND WIRES BEFORE WAX TAPE.

STEP 1

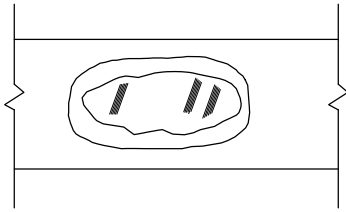

CHIP OUT MORTAR (CML&C) AND/OR FILE SURFACE TO BRIGHT METAL AND CLEAN

STEP 2

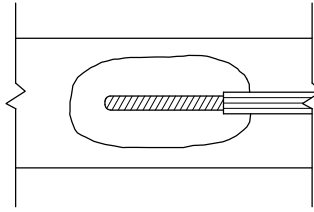

STRIP INSULATION FROM WIRE

STEP 3

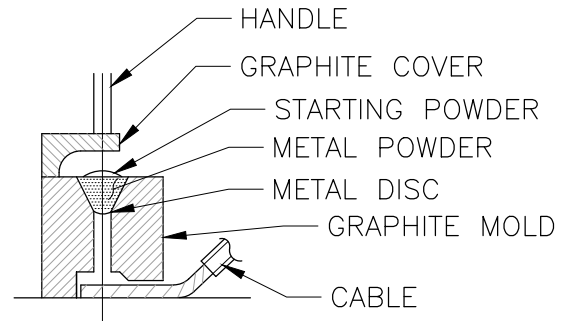

HOLD WELDER FIRMLY WITH OPENING AWAY FROM OPERATION AND IGNITE STARTING POWDER

STEP 4

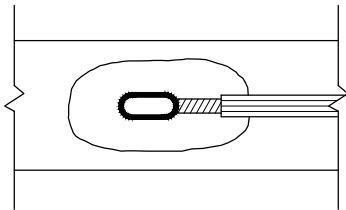

REMOVE SLAG FROM CONNECTION

STEP 5

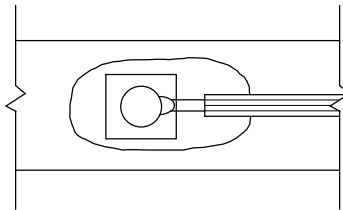

APPLY 2 COATS OF PRIMER AND COVER CONNECTION WITH A PREFORMED WELD CAP

STEP 6

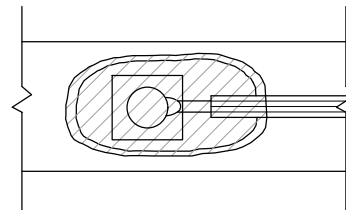

COAT AREA WITH BITUMEN. PATCH MORTAR. SEE NOTE 3

NOTES :

1. WELDER SHOWN IS FOR HORIZONTAL SURFACES. FOR VERTICAL SURFACES SIDE WELDER IS REQUIRED.
2. ALL WIRE WELDS SHALL BE 3 INCHES APART, MINIMUM.
3. APPLY GENEROUS COAT OF BITUMINOUS MASTIC OVER WELD CAP AND EXPOSED METAL AREA UP TO EDGE OF MORTAR (CML&C) OR 3" BEYOND WELD CAP (DIP).
4. PATCH MORTAR COATING WITH QUICK SETTING MORTAR (CML&C).

GENERAL OFF-SITE RECYCLED WATER NOTES

1. ALL MNWD GENERAL CONSTRUCTION NOTES (PER MNWD STANDARD DRAWING G-GN) AND ALL MNWD GENERAL POTABLE WATER NOTES (PER MNWD STANDARD DRAWING W-GN) SHALL APPLY.
2. ALL CONSTANT PRESSURE RECYCLED AND POTABLE WATER MAIN LINE PIPING INSTALLED ON THIS PROJECT SHALL BE IDENTIFIED IN ACCORDANCE WITH THE DISTRICT'S SPECIFICATIONS.
 - A. WARNING TAPES SHALL BE USED ON ALL CONSTANT PRESSURE MAIN LINE PIPING CARRYING RECYCLED OR POTABLE WATER.
 - B. WARNING TAPES SHALL BE A MINIMUM OF 6 INCHES WIDE FOR 6-INCH AND SMALLER PIPE AND 12 INCHES WIDE FOR 8-INCH AND LARGER PIPE. THE TAPE SHALL RUN CONTINUOUSLY FOR THE ENTIRE LENGTH OF ALL CONSTANT PRESSURE MAIN LINE PIPING, AND SHALL BE LOCATED 12 INCHES ABOVE THE TOP OF THE PIPE.
 - C. WARNING TAPE FOR THE CONSTANT PRESSURE RECYCLED WATER PIPING SHALL BE PURPLE IN COLOR WITH THE WORDS "CAUTION: RECYCLED WATER-LINE BURIED BELOW" IMPRINTED IN MINIMUM 1/2-INCH-HIGH LETTERS BLACK IN COLOR. IMPRINTING SHALL BE CONTINUOUS AND PERMANENT.
 - D. RECYCLED WATER DISTRIBUTION/TRANSMISSION MAINS SHALL BE PURPLE COLORED C900 PVC. DUCTILE IRON PIPE (DIP) MAY BE USED ONLY WITH SPECIAL PERMISSION FROM THE DISTRICT. IF DIP IS APPROVED, IT SHALL BE ENCASED WITHIN A PURPLE POLYETHYLENE SLEEVE.
 - E. ALTERNATELY TRANSMISSION/ DISTRIBUTION PIPING IN THE RECYCLED WATER SYSTEM, INCLUDING SERVICE LINES, VALVES, AND OTHER APPURTENANCES CAN BE COLORED PURPLE, PANTONE 522C, AND EMBOSSED OR BE INTEGRALLY STAMPED/MARKED CAUTION: RECYCLED WATER - DO NOT DRINK, OR BE INSTALLED WITH OR A PURPLE POLYETHYLENE VINYL WRAP, COLOR TO BE PANTONE 512C.
 - F. ALL SERVICE LINES SHALL BE ENCASED WITHIN A PURPLE COLORED POLYETHYLENE SLEEVE.
3. NEW RECYCLED WATER PIPE SHALL BE INSTALLED WITH A MINIMUM COVER OF 48" BELOW FINISHED SURFACE OR AS SHOWN ON PLANS (WHICHEVER IS GREATER).
4. RECYCLED WATER MAINS SHALL BE INSTALLED AFTER THE INSTALLATION OF CURB AND GUTTER AT SIX FEET OFF OF CURB FACE ON THE OPPOSITE SIDE OF THE STREET OF THE POTABLE WATER MAINS, UNLESS SHOWN OTHERWISE ON PLANS, OR AS STAKED BY THE APPLICANT'S SURVEYOR AT A MINIMUM 50-FOOT STATIONING IF NOT WITHIN A ROADWAY.
5. ALL VALVE COVERS ON OFF-SITE RECYCLED WATER FACILITIES SHALL BE CIRCULAR IN SHAPE WITH THE WORDS "RECYCLED" CAST THEREON, CONSTRUCTED AND MARKED PER THE MNWD STANDARD DRAWING W-8.
6. RECYCLED WATER MAINS SHALL NOT BE REQUIRED TO PASS DISINFECTION OR BACTERIOLOGICAL TESTS. PRESSURE AND LEAKAGE TEST PER SECTION 15042 OF THE STANDARD SPECIFICATIONS OF THE MOULTON NIGUEL WATER DISTRICT IS STILL REQUIRED, PRIOR TO ACCEPTANCE.
7. RECYCLED WATER SHALL BE USED TO FILL AND PRESSURE TEST RECYCLED WATER MAIN. ALL FLUSHING WATER SHALL BE CONVEYED TO SEWER MANHOLE. AN AIR GAP WILL BE REQUIRED. THIS SHALL BE CONDUCTED IN THE PRESENCE OF THE DISTRICT INSPECTOR.
8. CURBS SHALL BE INSCRIBED WITH A 2-INCH HIGH "RW" INDICATING LOCATIONS OF ALL RECYCLED WATER SERVICES.

GENERAL NOTE

THE STATE WATER RESOURCES CONTROL BOARD (SWRCB) AND STATE OF CALIFORNIA REGULATIONS (TITLE 22, CHAPTER 16 SECTION 64572) SHALL BE FOLLOWED WHEN DESIGNING AND CONSTRUCTING NEW POTABLE WATER, RECYCLED WATER, AND SEWER MAINS. WHEN SWRCB AND DISTRICT STANDARDS CONFLICT, THE MOST STRINGENT REQUIREMENT SHALL APPLY UNLESS OTHERWISE APPROVED BY THE DISTRICT.

BASIC SEPARATION STANDARDS

1. PARALLEL CONSTRUCTION: THE HORIZONTAL DISTANCE BETWEEN PRESSURE RECYCLED WATER AND THE FOLLOWING MAINS SHALL BE AT LEAST:
 - a) POTABLE WATER: 4'
 - b) SEWER: 10'
2. PERPENDICULAR CONSTRUCTION (CROSSING): PRESSURE POTABLE WATER MAINS SHALL BE AT LEAST ONE FOOT ABOVE RECYCLED WATER AND SEWER LINES WHERE THESE LINES MUST CROSS.

SPECIAL CONSTRUCTION REQUIRED FOR RECYCLED WATER

ZONE

"A" NO RECYCLED WATER LINES PARALLEL TO POTABLE OR SEWER LINES SHALL BE PERMITTED IN THIS ZONE WITHOUT APPROVAL FROM COUNTY AND STATE BOARD'S DIVISION OF DRINKING WATER AND THE DISTRICT. IF APPROVED, ZONE 'B' PIPE MATERIALS ARE REQUIRED UNLESS OTHERWISE REQUIRED.

"B" RECYCLED WATER MAINS SHALL BE CONSTRUCTED OF:

1. CLASS 200 PRESSURE RATED PLASTIC WATER PIPE (DR 14 PER AWWA C900) OR EQUIVALENT.
2. DUCTILE IRON PIPE.
3. HDPE PIPE WITH BUTT-FUSED JOINTS
4. CEMENT-MORTAR LINED AND COATED 1/4" THICK STEEL PIPE WITH WELDED JOINTS.

"C" RECYCLED WATER MAINS SHALL BE CONSTRUCTED OF:

1. DUCTILE IRON PIPE.
2. HDPE PIPE WITH BUTT-FUSED JOINTS
3. CEMENT-MORTAR LINED AND COATED 1/4" THICK STEEL PIPE WITH WELDED JOINTS.

"D" RECYCLED WATER MAINS SHALL BE CONSTRUCTED OF:

1. CLASS 200 PRESSURE RATED PLASTIC WATER PIPE (DR 14 PER AWWA C900) OR EQUIVALENT.
2. DUCTILE IRON PIPE.
3. HDPE PIPE WITH BUTT-FUSED JOINTS
4. CEMENT-MORTAR LINED AND COATED 1/4" THICK STEEL PIPE WITH WELDED JOINTS.

"P" NO RECYCLED WATER MAIN SHALL BE CONSTRUCTED PER SECTION 64630 (2) CALIFORNIA ADMINISTRATIVE CODE, TITLE 22.

S = SEWER MAIN
PW = POTABLE WATER MAIN

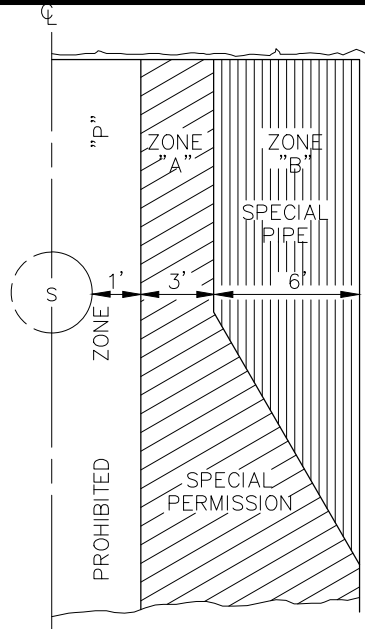

RECYCLED WATER MAIN PARALLEL TO SEWER MAINS

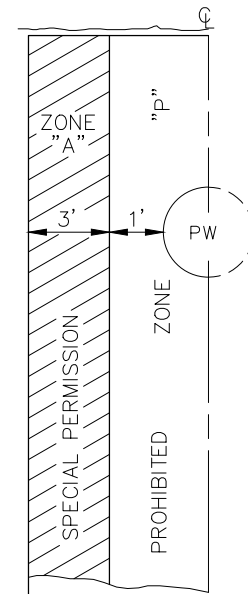

RECYCLED WATER MAIN PARALLEL TO POTABLE WATER MAINS

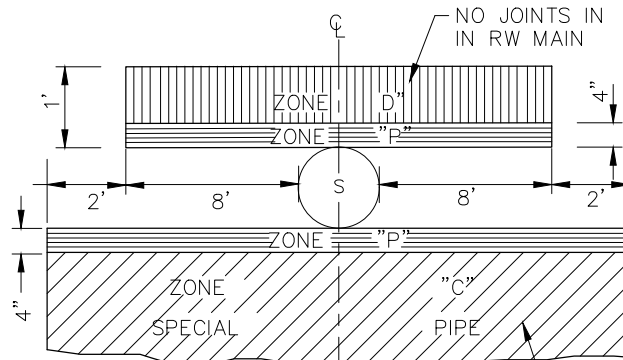

RECYCLED WATER MAIN CROSSING SEWER MAINS

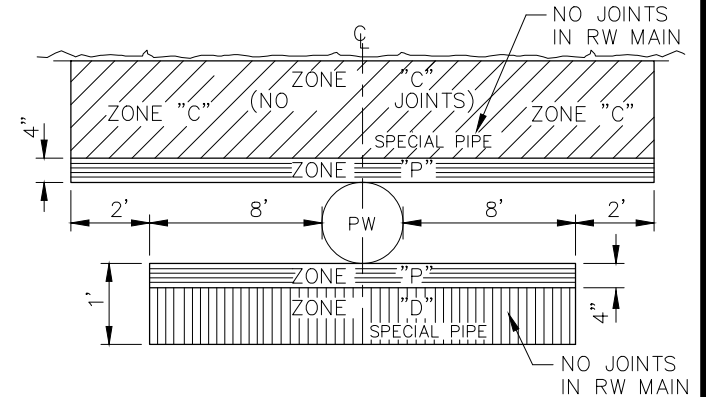

RECYCLED WATER MAIN CROSSING POTABLE WATER MAINS

NOTE: "P" IS A PROHIBITED CONSTRUCTION ZONE.

MOULTON NIGUEL WATER DISTRICT
DESIGN CRITERIA FOR SEPARATION OF POTABLE WATER AND SEWER MAINS FOR NEW RECYCLED WATER MAINS

RW-1
AUGUST 2024

GENERAL SEWER NOTES

1. ALL MNWD GENERAL CONSTRUCTION NOTES SHALL APPLY (PER MNWD STANDARD DRAWING G-GN).
2. ANY WORK TO BE PERFORMED INSIDE A LIVE MANHOLE SHALL BE DONE IN ACCORDANCE WITH CAL OSHA "CONFINED SPACES" AND DISTRICT MANHOLE ENTRY REGULATIONS. MANHOLE ENTRY WITHOUT DISTRICT APPROVAL AND DISTRICT PERSONNEL PRESENT IS NOT ALLOWED.
3. BYPASS PUMPING OF SEWAGE SHALL REQUIRE AN ENGINEERED BYPASS PLAN, TO BE SUBMITTED FOR REVIEW AND ACCEPTANCE BY MNWD STAFF, PER MNWD STANDARD SPECIFICATION 01550 BYPASS PUMPING. BYPASS PLAN MAY INCLUDE: PUMPS AND ABOVE-GROUND HDPE OR VICTAULIC-COUPLED TEMPORARY PIPELINES TO AN AVAILABLE DOWNSTREAM MANHOLE, PUMPING SEWAGE INTO TANKER TRUCKS AND DISCHARGING INTO A SEWER MANHOLE AS DIRECTED BY MNWD, AND/OR FLOW THROUGH PLUGS INSTALLED BETWEEN EXISTING AND NEWLY INSTALLED SEWER MAINS. REGULAR FLOWS SHOULD BE REESTABLISHED AT THE END OF EACH WORK DAY. ALL BYPASS EFFORTS SHALL BE MONITORED FULL TIME FOR THE DURATION OF THE BYPASS.
4. SEWER MAINS SHALL BE INSTALLED 5 FEET OFF THE STREET CENTERLINE UNLESS SHOWN OTHERWISE ON PLANS, OR AS STAKED BY THE APPLICANT'S SURVEYOR AT A MINIMUM 50-FOOT STATIONING IF NOT WITHIN A ROADWAY.
5. MNWD WILL INSPECT AND MAINTAIN ALL PUBLICLY-OWNED SEWERS AND MANHOLES. THE DISTRICT WILL NOT INSPECT NOR MAINTAIN PRIVATE LATERALS. THE ORANGE COUNTY DEPARTMENT OF BUILDING AND SAFETY, THE GOVERNING MUNICIPALITY, OR APPROPRIATE GOVERNING AGENCY WILL INSPECT AND VERIFY ALL PRIVATELY OWNED LATERALS TO THE BUILDINGS.
6. ALL SEWER MAINS SHALL BE REQUIRED TO PASS PRESSURE, LEAKAGE, INFILTRATION, AND DEFLECTION TESTING PER SECTION 15043 OF THE STANDARD SPECIFICATIONS OF THE MOULTON NIGUEL WATER DISTRICT PRIOR TO ACCEPTANCE.
7. THE CONTRACTOR SHALL BE RESPONSIBLE FOR BRINGING MANHOLES TO GRADE AFTER FINAL PAVEMENT IS PLACED.
8. ALL SEWER LATERAL TIE-INS SHALL BE MADE IN THE PRESENCE OF AN AUTHORIZED DISTRICT INSPECTOR.
9. ALL SEWER MANHOLE LIDS SHALL BE AS SHOWN IN STANDARD DRAWINGS S-3 AND S-4 OF MOULTON NIGUEL WATER DISTRICT'S "STANDARD SPECIFICATIONS FOR CONSTRUCTION OF POTABLE WATER, RECYCLED WATER, AND WASTEWATER FACILITIES."
10. CURBS SHALL BE INSCRIBED WITH A 2-INCH HIGH "S" INDICATING LOCATION OF ALL SEWER LATERALS.

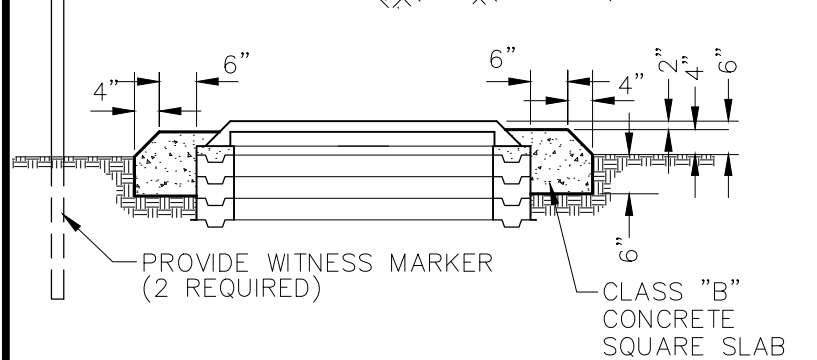
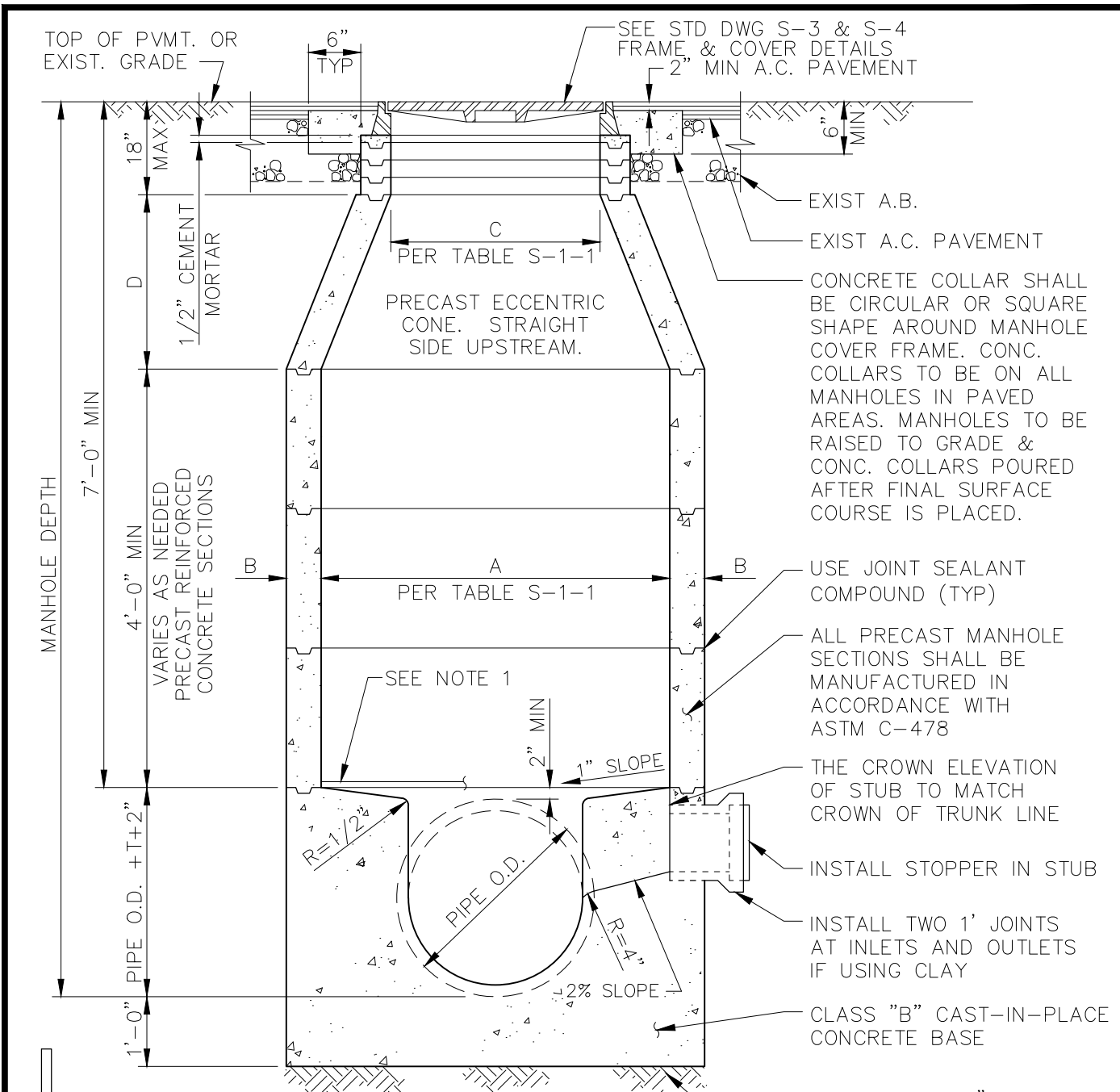

TOP OF MANHOLE
IN UNIMPROVED AREA

TABLE S-1-1

MH. DEPTH	A	B	C	D
<12'	48"	6"	24"	24"
12'-16'	60"	6"	36"	32"
16'<	72"	7"	36"	36"

- NOTES:
- LADDER RUNGS SHALL NOT BE INSTALLED IN MANHOLE SECTIONS.
 - MANHOLES LOCATIONS SHALL BE ETCHED ON CURB FACE.

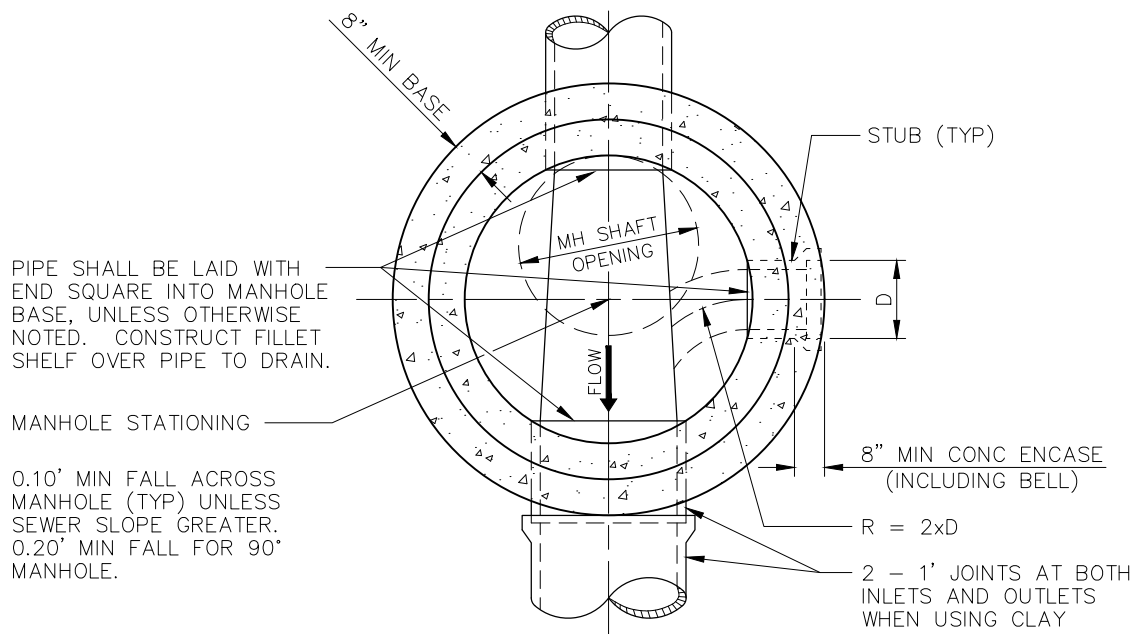

PLAN

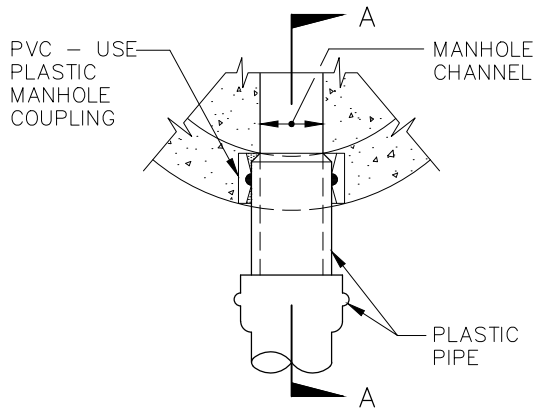

PLAN

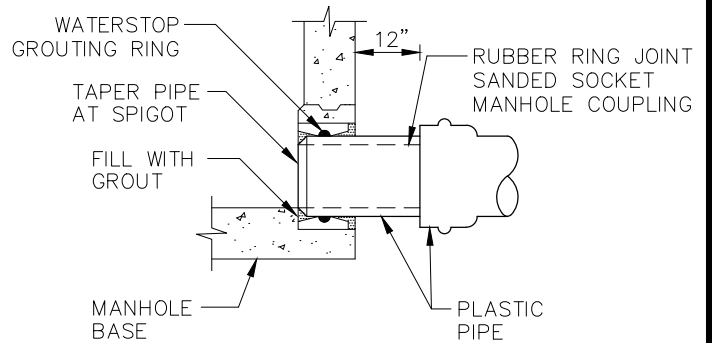

SECTION A-A

MANHOLE CONNECTION DETAILS

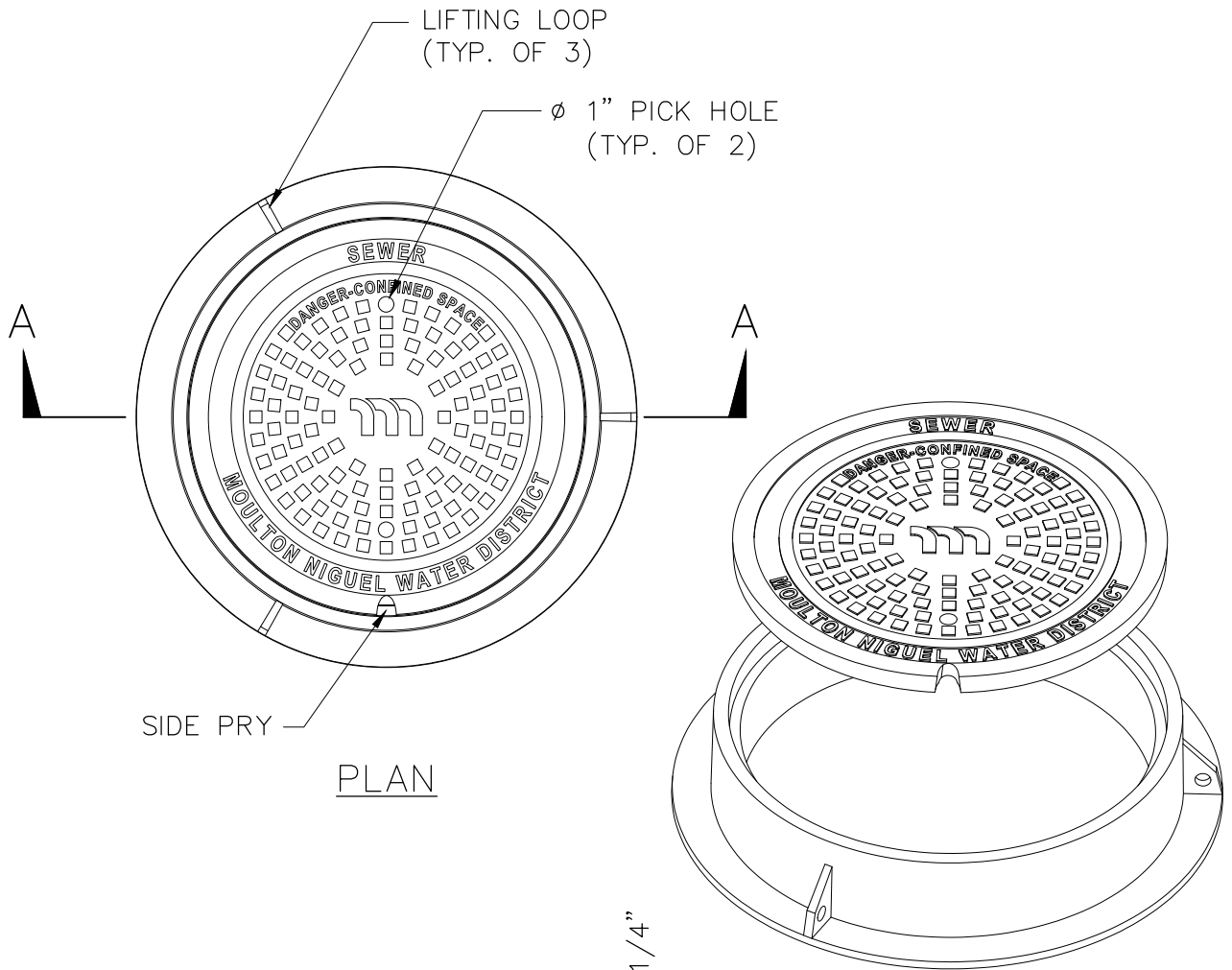

SIDE PRY

PLAN

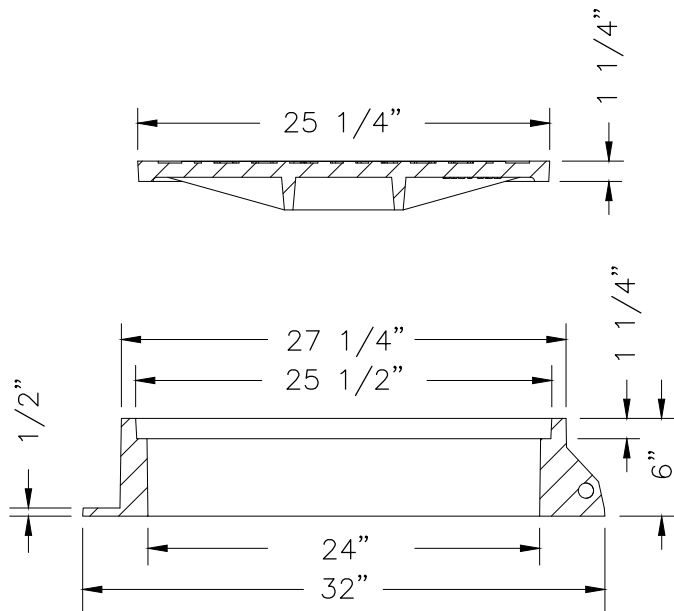

SECTION A-A

MOULTON NIGUEL WATER DISTRICT		S-3 AUGUST 2024
MANHOLE FRAME AND COVER FOR 48" MANHOLE		

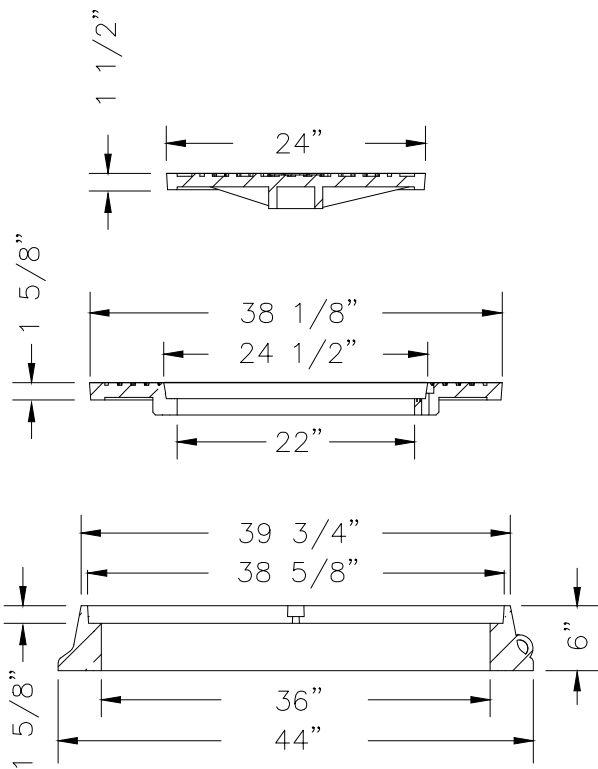
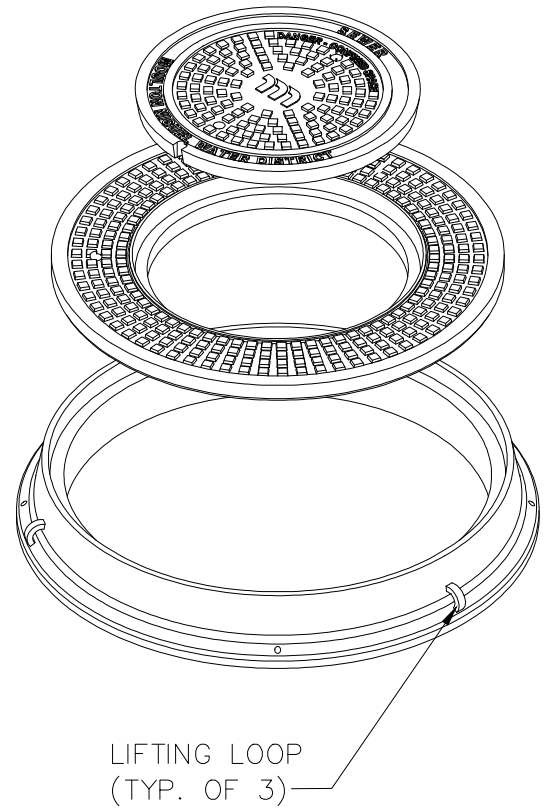
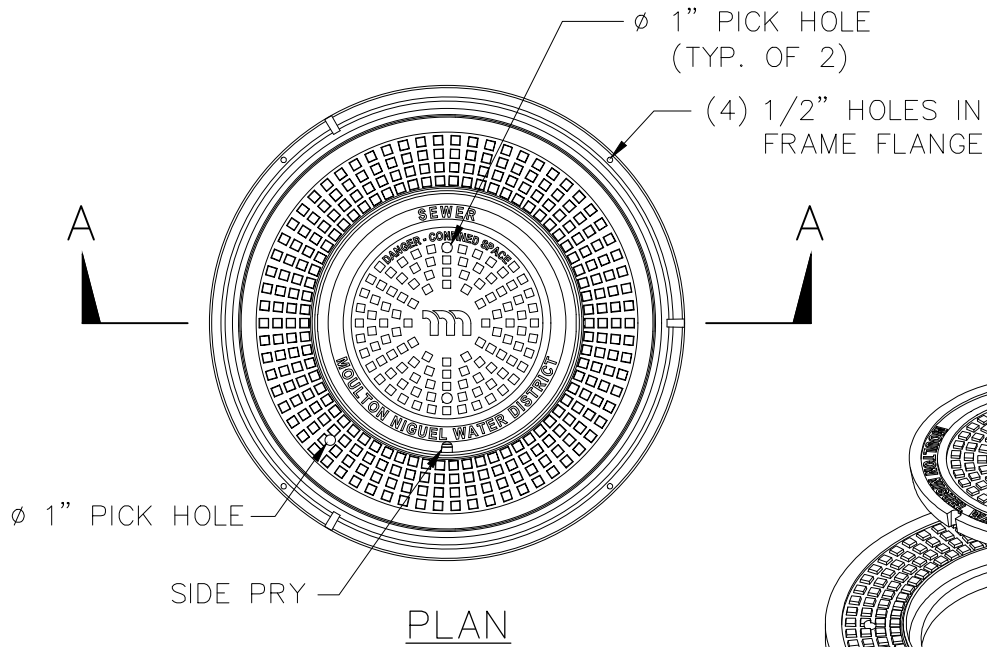

SECTION A-A

MOULTON NIGUEL WATER DISTRICT		S-4 AUGUST 2024
36" MANHOLE FRAME AND TWO CONCENTRIC COVERS FOR 60" AND 72" MANHOLE		

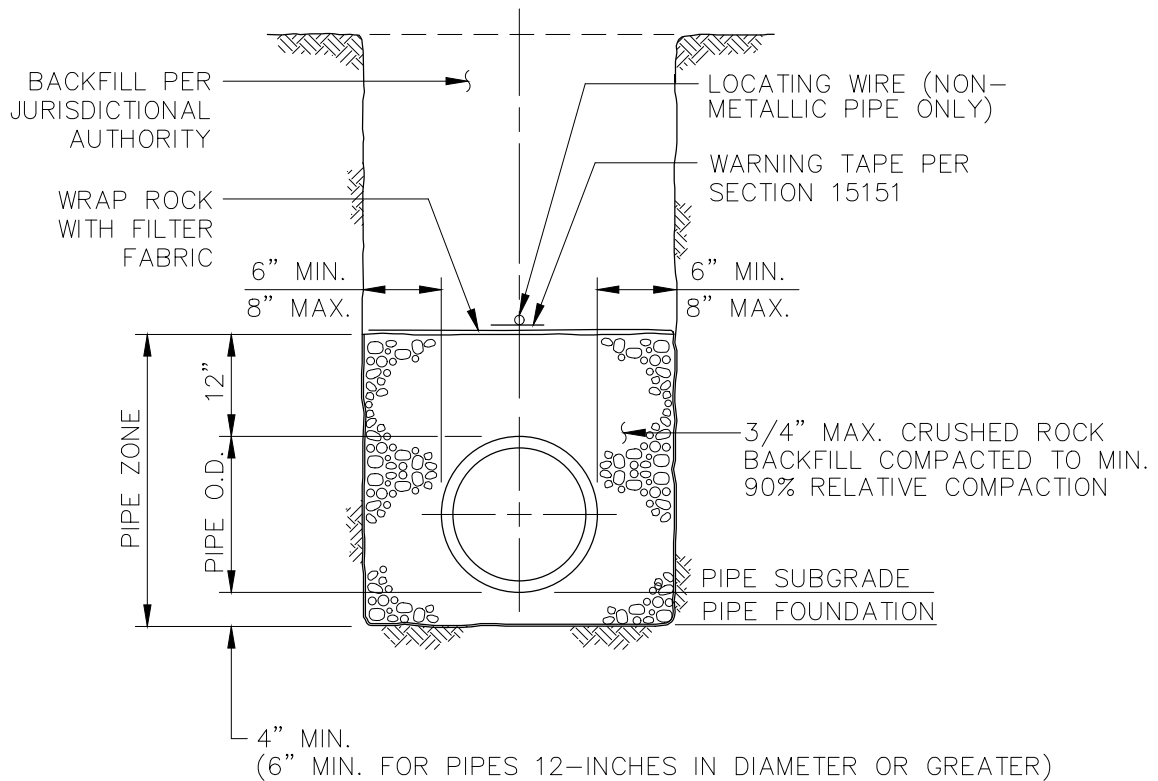

NORMAL BEDDING

NOTES:

1. NORMAL BEDDING SHALL BE USED FOR DEPTH OF COVER >4' OR <17' FOR PIPE BEDDING FOR DEPTH OF COVER >17' TO BE DETERMINED BY THE DISTRICT.
2. CONCRETE ENCASEMENT SHALL BE USED WHERE THE TRENCH WIDTH AT THE UPPER LIMITS OF THE PIPE ZONE EXCEEDS THE MAX. WIDTH SPECIFIED ABOVE.
3. SEE STD. DWGS. S-1 AND S-2 FOR MANHOLE DETAILS.
4. AFTER COMPACTION OF THE BACKFILL HAS BEEN ACHIEVED, ALL SEWER PIPE SHALL BE MANDREL TESTED, AIR TESTED AND VIDEOED PRIOR TO PAVEMENT AND HOUSE CONNECTION.
5. ALL EXCAVATIONS AND TRENCHES SHALL BE PROTECTED IN ACCORDANCE WITH THE CALIFORNIA DEPARTMENT OF INDUSTRIAL RELATIONS (CALOSHA) CODE OF REGULATIONS TITLE 8, SUBCHAPTER 4 "CONSTRUCTION SAFETY ORDERS".
6. OVEREXCAVATE TO REMOVE UNSUITABLE SOIL IF NECESSARY AND RE-ESTABLISH GRADE WITH 3/4" CRUSHED ROCK. DISTRICT TO DETERMINE DEPTH AND WIDTH OF REMOVAL.

MOULTON NIGUEL WATER DISTRICT

PVC & VCP PIPE BEDDING

S-5
AUGUST 2024

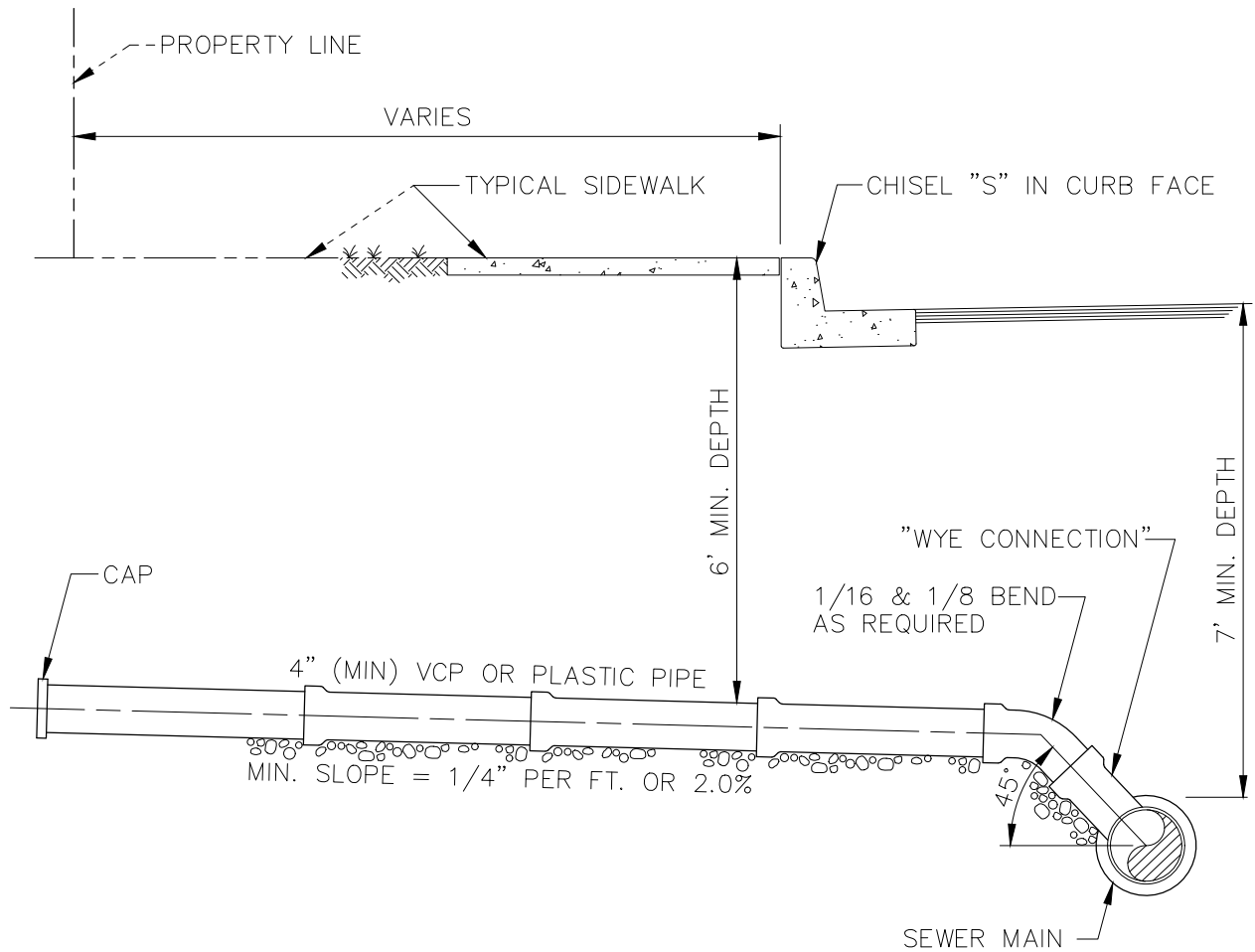

NOTES:

1. LATERAL SIZE TO BE DETERMINED ON THE BASIS OF TOTAL NUMBER OF FIXTURE UNITS DRAINED, BUT IN NO CASE SHALL THE LATERAL BE LESS THAN 4" FOR SINGLE OR MULTIPLE FAMILY RESIDENTIAL. SIX INCHES FOR COMMERCIAL OR INDUSTRIAL.
2. BEDDING AND BACKFILL OF LATERAL PER S-5 OR S-8.
3. WHERE SEWER WYE IS INSTALLED WITHOUT A HOUSE LATERAL, THE WYE SHALL BE PLUGGED WITH A SDR 35 PVC CAP.
4. LATERAL CONNECTION TO THE DISTRICT COLLECTION SYSTEM – SHALL BE CONSTRUCTED IN ACCORDANCE WITH COUNTY OF ORANGE, OR CITY REQUIREMENTS. PLUG AT PROPERTY LINE WITH SDR 35 PVC CAP.
5. PROPERTY OWNER IS REQUIRED TO MAINTAIN AND REPAIR LATERAL AND "WYE" CONNECTION, IT IS NOT MNWD RESPONSIBILITY.
6. LOCATE SEWER WITH A 2" HIGH "S" CHISELED IN CURB FACE WHERE THE LATERAL CROSSES UNDER THE CURB. WHERE NO CURB EXISTS, OR WHERE THE LATERAL ENDS 8' OR MORE BACK OF CURB, PLACE A 4" X 4" X 3'-0" STAKE EXTENDING 2" ABOVE FINISHED GRADE.

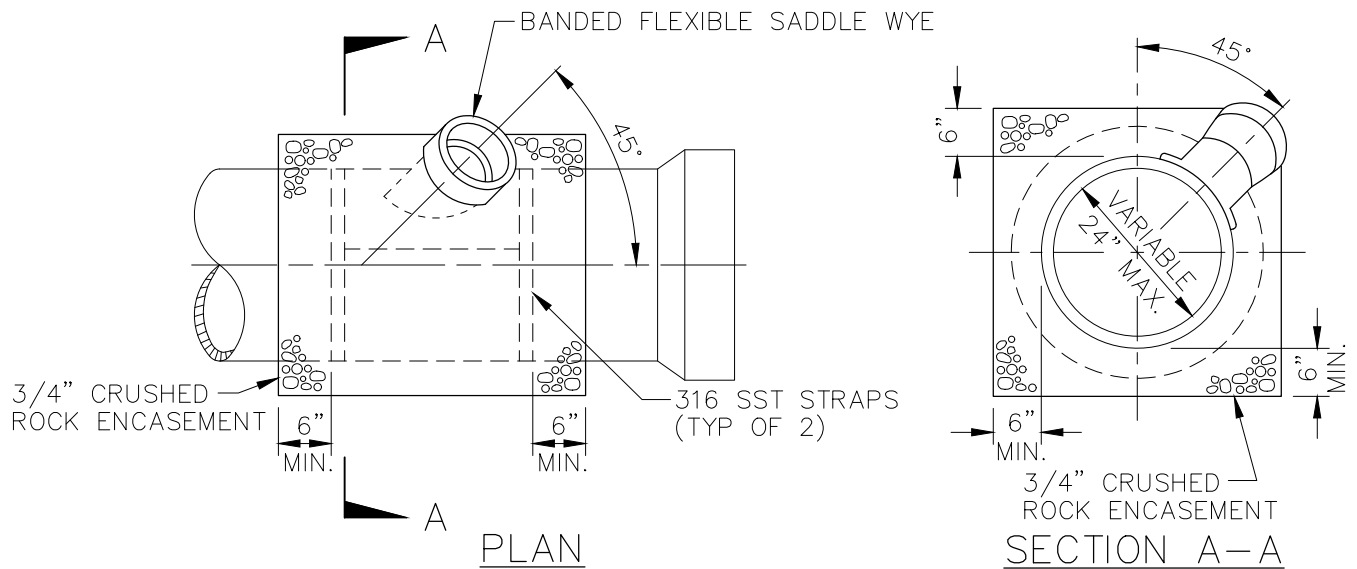

BANDED FLEXIBLE SADDLE WYE CONNECTION

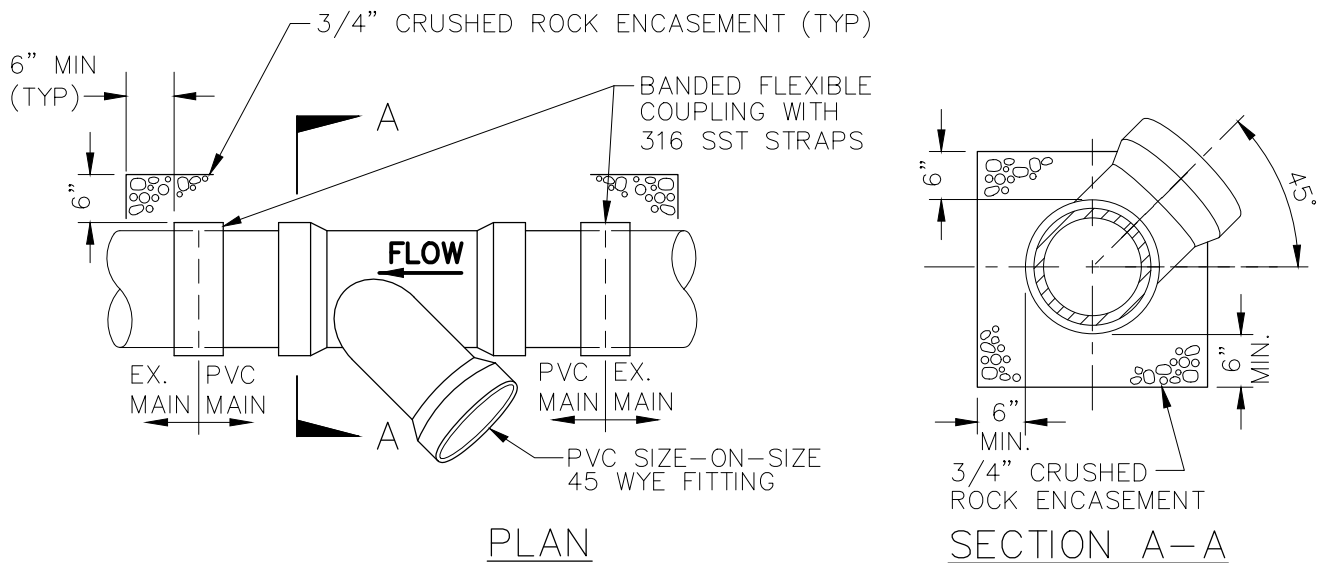

CUT-IN WYE CONNECTION

NOTES:

1. BANDED FLEXIBLE SADDLE WYES SHALL BE USED WHEN CONNECTING A SMALLER SIZED LATERAL TO A LARGER SIZED MAIN. A CUT-IN WYE SHALL BE USED WHEN LATERAL CONNECTION IS SIZE-ON-SIZE WITH THE MAIN.
2. THE HOLE SHALL BE CLEANLY MACHINED AND IF NECESSARY WORKED BY HAND WITH A RASP OR SANDED TO ACCOMPLISH A TRUE AND NEAT OPENING FOR THE SADDLE WYE.
3. THE APPLICANT SHALL ENCASE SADDLE CONNECTION AND CUT-IN WYES WITH 3/4" CRUSHED ROCK AFTER THE CONNECTION IS APPROVED BY THE INSPECTOR TO THE LIMITS INDICATED ABOVE. CRUSHED ROCK ENCASEMENT TO EXTEND 6 INCHES (MIN) BEYOND STRAPS OF BANDED SADDLE OR BANDED COUPLINGS. VIBRATE CRUSHED ROCK TO COMPACT.
4. THE APPLICANT SHALL KEEP ALL CHIPS, DIRT, EPOXY, MORTAR, AND CONCRETE OUT OF THE SEWER SADDLED, AND SHALL PERFORM A CLEANING AND BAILING OF THE REACH SADDLED IF DIRECTED TO DO SO BY THE INSPECTOR.
5. THE APPLICANT SHALL REPAIR OR REPLACE ANY DAMAGED PIPE AS DIRECTED BY THE INSPECTOR.

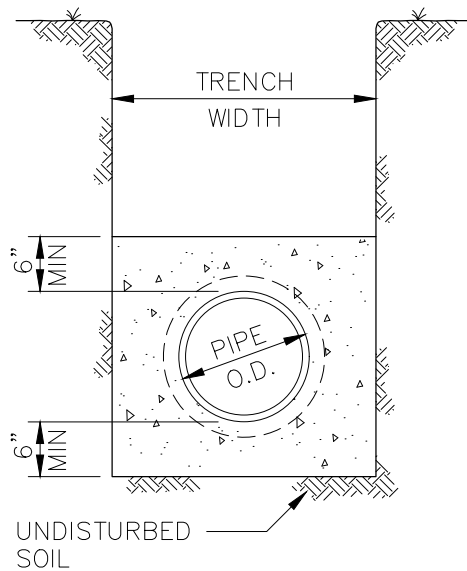

TYPE "A"

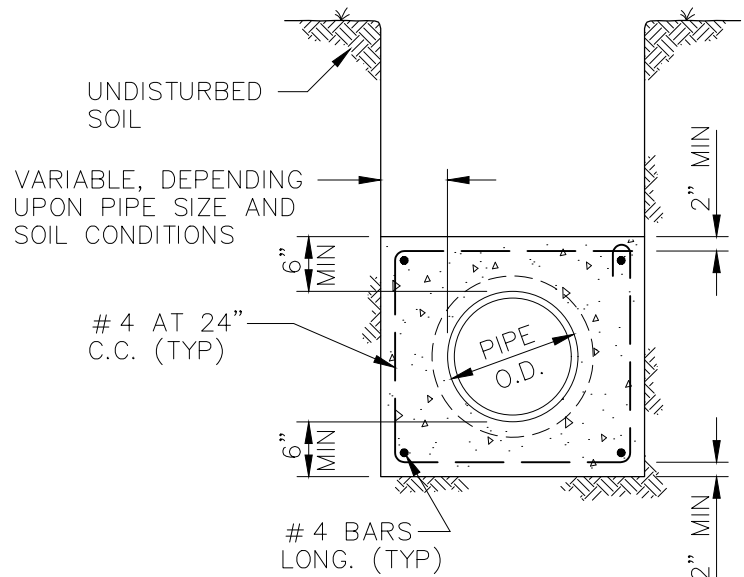

TYPE "B"

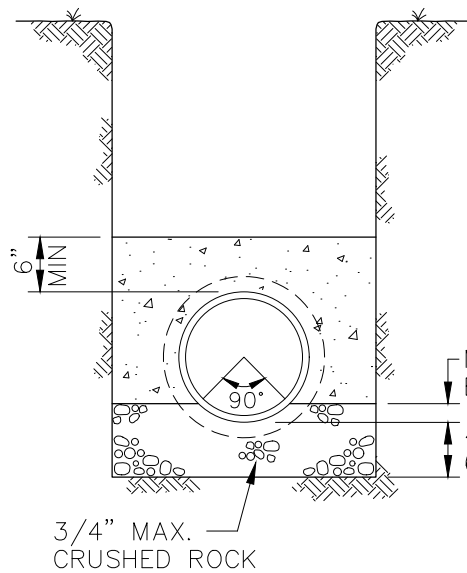

TYPE "C"

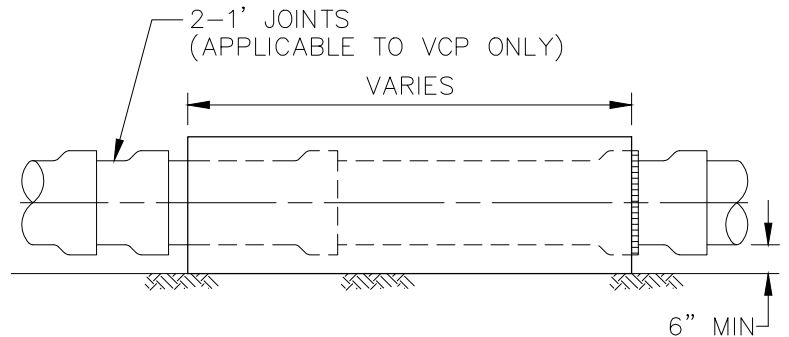

SECTION

MIN. DETERMINED BY PIPE SIZE
 4" MIN. - 6", 8" & 10" PIPE
 6" MIN. - 12" PIPE & GREATER

NOTES:

1. USE CONCRETE ENCASEMENT WHEN COVER IS UNDER 4' OR OVER 17'.
2. PLACE ENCASEMENT AGAINST UNDISTURBED NATURAL GROUND OR FILL COMPACTED TO 90% RELATIVE COMPACTION.
3. NO. 4 STEEL REINFORCING BARS UNLESS OTHERWISE NOTED.
4. USE TYPE OF CONCRETE ENCASEMENT AS SHOWN ON PLANS OR AS SPECIFIED BY INSPECTOR TO MEET UNFORESEEN CONDITIONS.
5. PROVIDE VERTICAL TRENCH WALLS FOR A MINIMUM OF 12" ABOVE TOP OF PIPE.
6. ENCASEMENT CONCRETE TO BE CLASS "B" PER SECTION 03300.
7. FOR DUCTILE IRON PIPE, CONTINUE POLYETHYLENE ENCASEMENT THROUGH CONCRETE ENCASEMENT.

MOULTON NIGUEL WATER DISTRICT

CONCRETE ENCASEMENT TYPE A, B & C

S-8
 AUGUST 2024

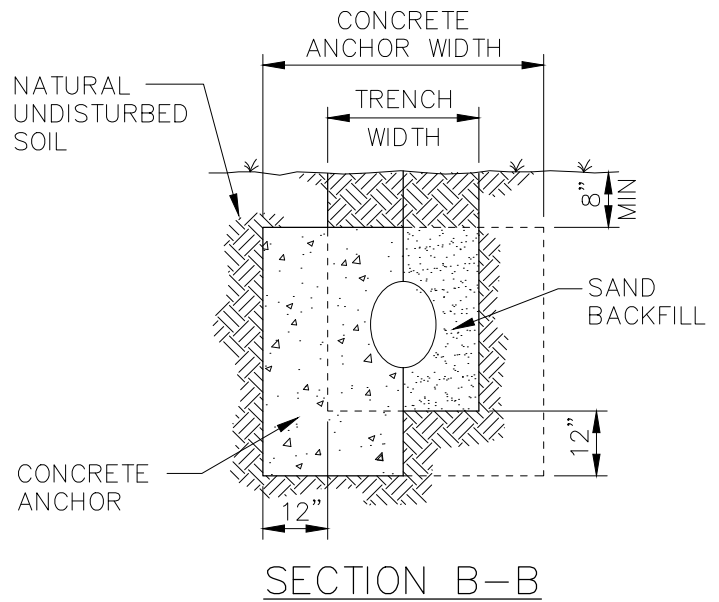
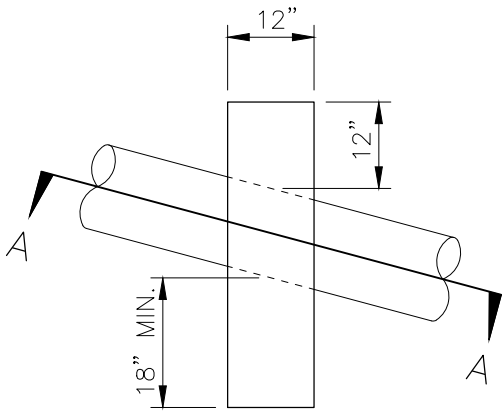
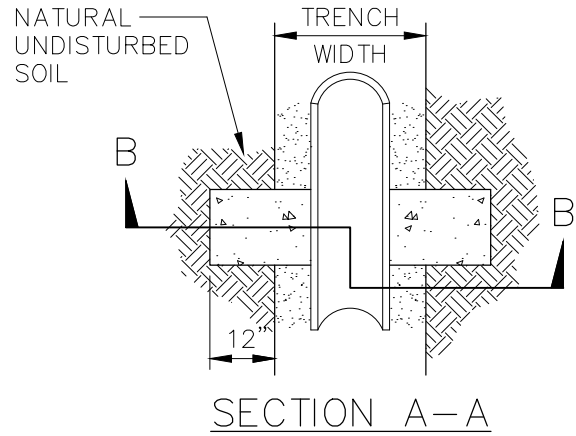
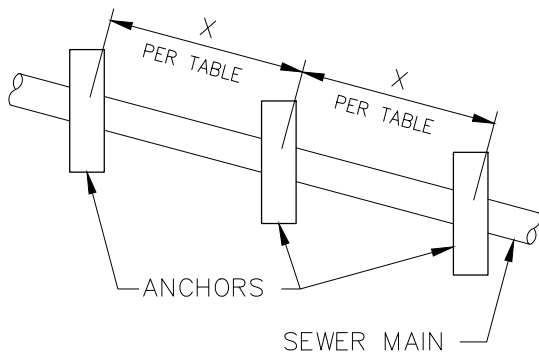

TABLE

PIPE SLOPE	X DISTANCE
20% TO 35%	36'
35% TO 50%	24'
> 50%	16'

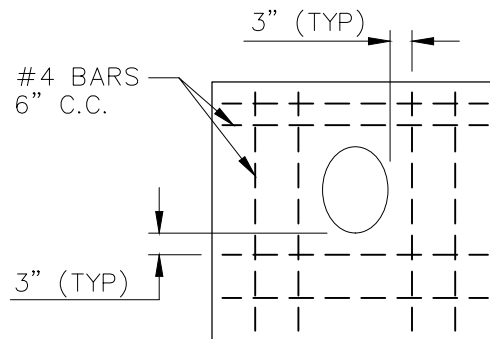

REINFORCING STEEL PATTERN

NOTES:

1. PIPE ANCHORS REQUIRED ON ALL SLOPES OF 20% OR GREATER.
2. ANCHOR SHALL EXTEND 12" INTO NATURAL UNDISTURBED SOIL.
3. CONCRETE SHALL BE CLASS "B" PER SECTION 03300.
4. ANCHORS FOR TRAPEZOIDAL TRENCH SECTIONS WILL CONFORM TO TRENCH CROSS SECTION AND EXTEND 12" INTO UNDISTURBED SOIL.

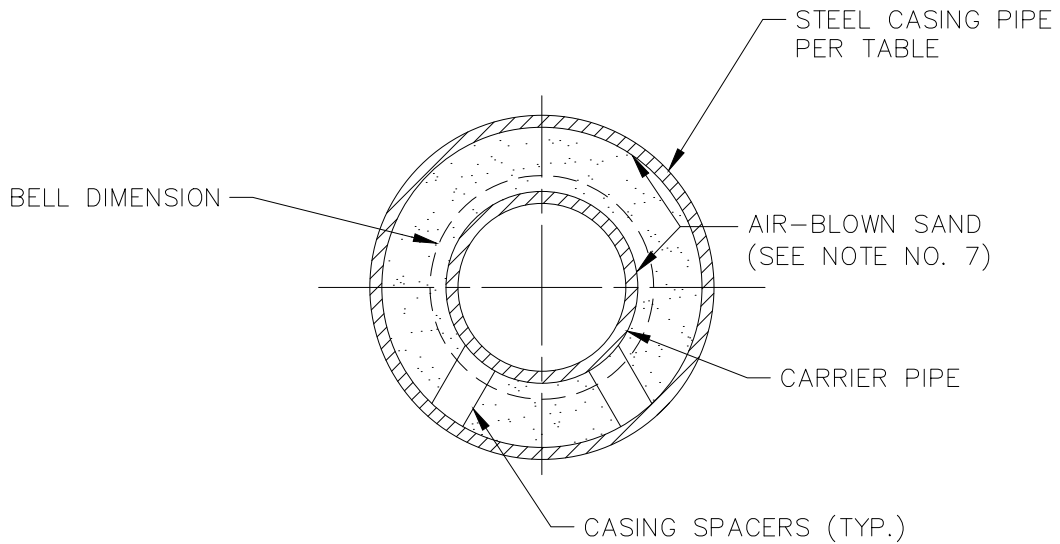

STEEL CASING DIMENSION TABLE

<u>PVC SIZE</u>	<u>MIN. CASING SIZE</u>	<u>MIN. CASING THICKNESS</u>	<u>VCP SIZE</u>	<u>MIN. CASING SIZE</u>	<u>MIN. CASING THICKNESS</u>
6"	12" I.D.	1/4"	6"	16" I.D.	1/4"
8"	16" I.D.	1/4"	8"	18" I.D.	1/4"
10"	18" I.D.	5/16"	10"	21" I.D.	5/16"
12"	20" O.D.	5/16"	12"	24" O.D.	5/16"

NOTES:

1. CASING SHALL BE INSTALLED BY THE BORE, JACK AND/OR TUNNEL METHOD.
2. CARRIER PIPE SHALL BE AIR TESTED PRIOR TO FILLING CASING.
3. UPSTREAM AND DOWNSTREAM ELEVATIONS TO BE VERIFIED PRIOR TO FILLING CASING.
4. ALL CASING SECTIONS TO BE JOINED BY CONTINUOUS WELD.
5. CASING SHALL BE SEALED WITH AN END SEAL.
6. ALL PIPE JOINTS WITHIN THE CASING SHALL BE RESTRAINED.
7. UNLESS OTHERWISE NOTED ON THE PLANS, THE ANNULAR SPACE WITHIN THE CASING SHALL BE FILLED WITH AIR BLOWN SAND.

GENERAL NOTE

THE STATE WATER RESOURCES CONTROL BOARD (SWRCB) AND STATE OF CALIFORNIA REGULATIONS (TITLE 22, CHAPTER 16 SECTION 64572) SHALL BE FOLLOWED WHEN DESIGNING AND CONSTRUCTING NEW POTABLE WATER, RECYCLED WATER, AND SEWER MAINS. WHEN SWRCB AND DISTRICT STANDARDS CONFLICT, THE MOST STRINGENT REQUIREMENT SHALL APPLY UNLESS OTHERWISE APPROVED BY THE DISTRICT.

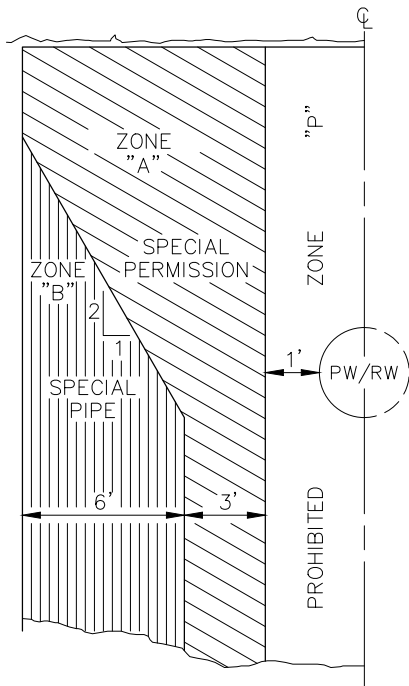

SEWER MAIN PARALLEL TO POTABLE/RECYCLED WATER MAIN

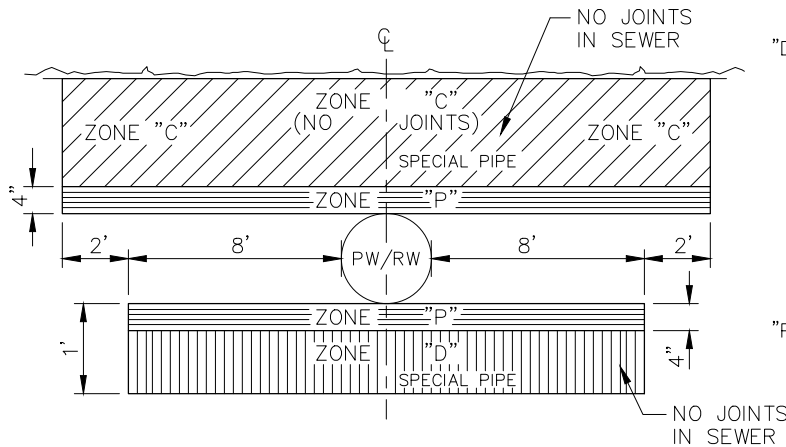

NOTE: "P" IS A PROHIBITED CONSTRUCTION ZONE.

SEWER MAIN CROSSING POTABLE/RECYCLED WATER MAIN

PW = POTABLE WATER MAIN
RW = RECYCLED WATER MAIN

BASIC SEPARATION STANDARDS

1. PARALLEL CONSTRUCTION: THE HORIZONTAL DISTANCE BETWEEN PRESSURE POTABLE WATER AND RECYCLED WATER MAINS AND SEWER LINES SHALL BE AT LEAST 10 FEET.
2. PERPENDICULAR CONSTRUCTION (CROSSING): PRESSURE POTABLE WATER MAINS SHALL BE AT LEAST ONE FOOT ABOVE SEWER AND RECYCLED WATER LINES WHERE THESE LINES MUST CROSS.

SPECIAL CONSTRUCTION REQUIRED FOR SEWER

ZONE

- "A" NO SEWER LINES PARALLEL TO POTABLE OR RECYCLED WATER LINES SHALL BE PERMITTED IN THIS ZONE WITHOUT APPROVAL FROM COUNTY AND STATE BOARD'S DIVISION OF DRINKING WATER AND THE DISTRICT. IF APPROVED, ZONE 'B' PIPE MATERIALS ARE REQUIRED UNLESS OTHERWISE REQUIRED.
- "B" SEWER MAIN SHALL BE CONSTRUCTED OF:
1. SDR 35 PVC SEWER PIPE.
 2. EXTRA STRENGTH VITRIFIED CLAY PIPE.
 3. DUCTILE IRON PIPE WITH PUSH-ON JOINTS
- "C" A SEWER MAIN SHALL BE CONSTRUCTED OF:
1. A CONTINUOUS SECTION OF SDR 35 PVC PIPE.
 2. CONTINUOUS SECTION OF DUCTILE IRON PIPE.
 3. ANY SEWER PIPE WITHIN A CONTINUOUS SLEEVE OR 6" THICK CONCRETE ENCASEMENT.
- "D" A SEWER MAIN SHALL BE CONSTRUCTED OF:
1. A CONTINUOUS SECTION OF SDR 35 PVC PIPE.
 2. CONTINUOUS SECTION OF DUCTILE IRON PIPE.
 3. ANY SEWER PIPE WITHIN A CONTINUOUS SLEEVE OR 6" THICK CONCRETE ENCASEMENT.
 4. ANY SEWER PIPE SEPARATED BY A 10' X 10' X 4"-THICK REINFORCED CONCRETE SLAB.
- "P" NO SEWER MAIN SHALL BE CONSTRUCTED PER SECTION 64630 (2) CALIFORNIA ADMINISTRATIVE CODE, TITLE 22.

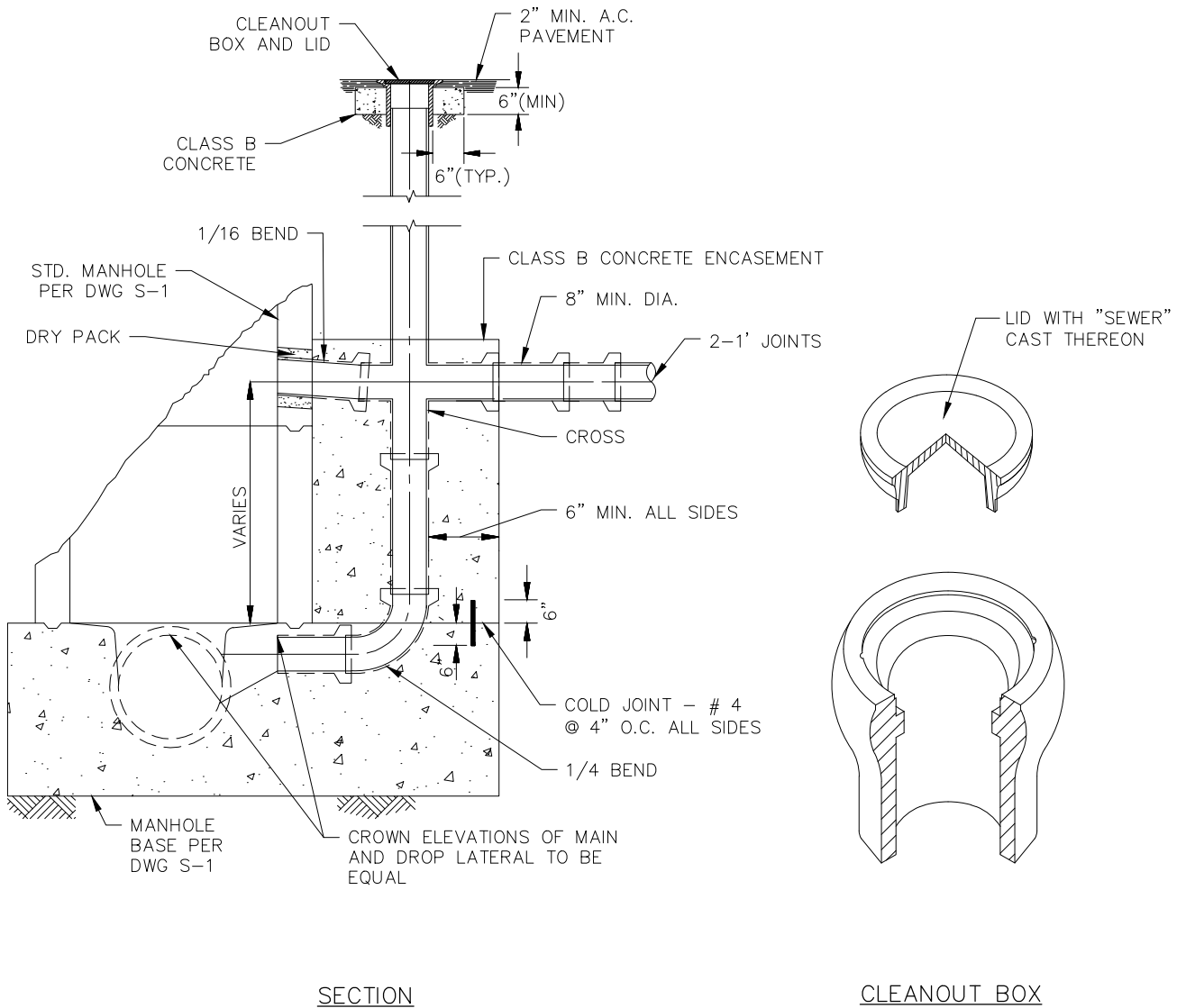

NOTES

1. DROP MANHOLE ONLY TO BE USED FOR SPECIAL SITUATIONS, AND SHALL NOT BE CONSTRUCTED WITHOUT DISTRICT APPROVAL.
2. ALL NEW OPENINGS CONSTRUCTED INTO MANHOLE SHALL BE DONE BY CORE DRILLING.
3. CONTRACTOR SHALL BE RESPONSIBLE FOR RAISING CLEANOUT BOXES TO GRADE AFTER STREET IS PAVED 1ST LIFT AND 2ND LIFT.

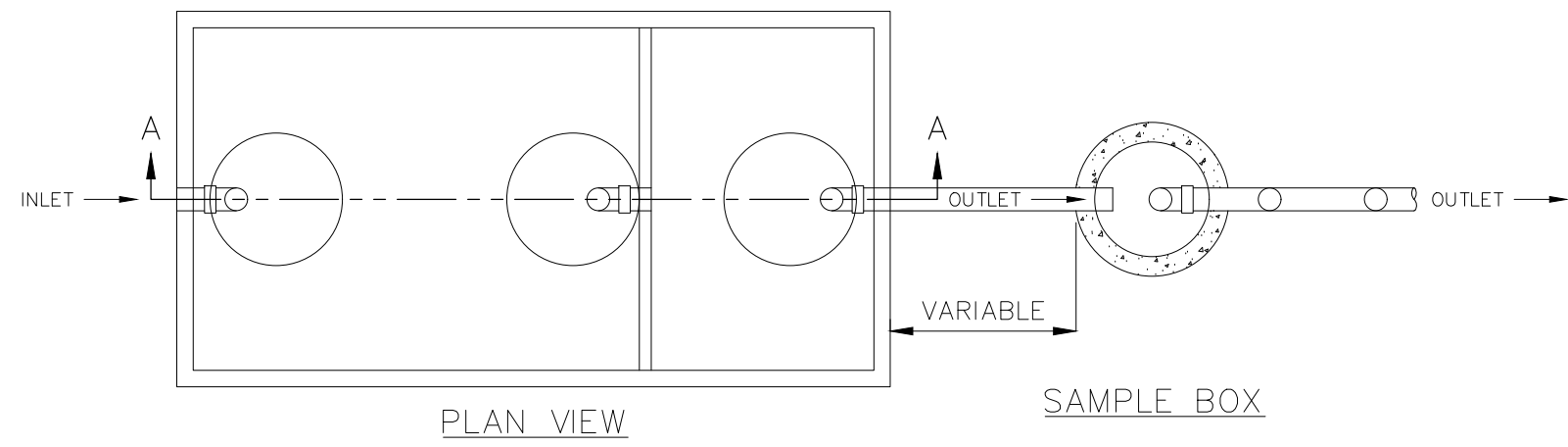

PLAN VIEW

SAMPLE BOX

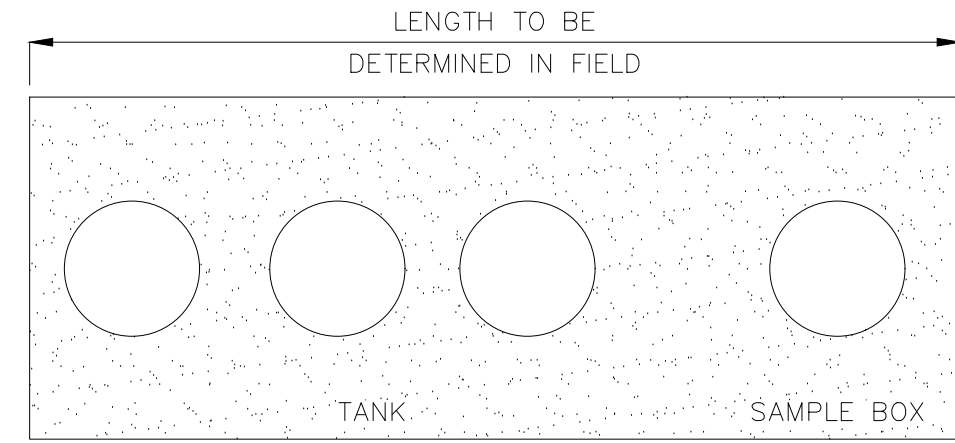

CONCRETE COLLAR DETAIL
PLAN VIEW

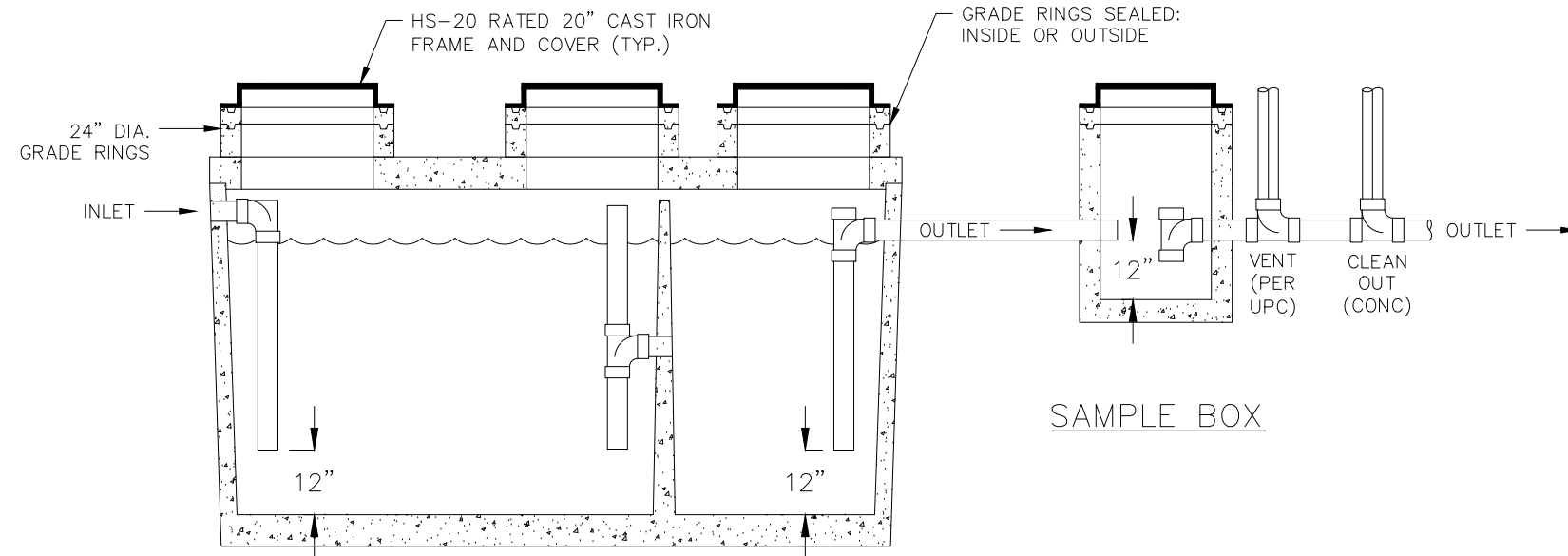

SIDE VIEW

SAMPLE BOX



CONCRETE COLLAR DETAIL
PLAN VIEW

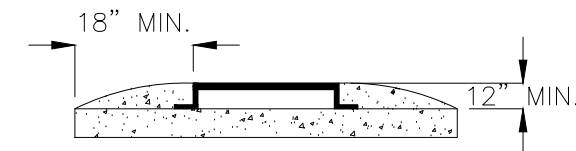

CONCRETE COLLAR DETAIL
PLAN VIEW

REQUIREMENTS:

1. SIZE AND LOCATION OF INTERCEPTOR TO BE APPROVED PRIOR TO INSTALLATION.
2. INTERCEPTOR TO INCLUDE:
 - A. SAMPLE BOX
 - B. SANITARY TEE; INSIDE SAMPLE BOX, DISCHARGE SIDE
 - C. VENT
 - D. CLEANOUT PRIOR TO LATERAL CONNECTION
 - E. MANHOLE AT EACH INTERNAL BAFFLE – NO MORE THAN 10’ BETWEEN MANHOLES
 - F. OUTLET SHALL BE SAME DIAMETER AS INLET
 - G. INTERIOR OF INTERCEPTOR , INCLUDING ROOF, SHALL BE COATED WITH A PROTECTIVE COATING
3. INSPECTION OF INTERCEPTOR
 - A. ALL CONNECTIONS TO INTERCEPTOR TO BE INSPECTED BY THE DISTRICT INSPECTOR PRIOR TO BACKFILL
 - B. NOTIFY DISTRICT A MINIMUM OF 72 HOURS IN ADVANCE OF INSTALLATION TO SCHEDULE REQUIRED INSPECTIONS.
 - C. INTERCEPTOR TO BE FILLED WITH WATER PRIOR TO INSPECTION, PER MANUFACTURER’S INSTRUCTIONS OR REQUEST
4. ALL MANHOLES AND SAMPLE BOXES TO BE INSTALLED A MINIMUM OF 1/2” ABOVE FINISH GRADE/PAVEMENT WITH A CONCRETE COLLAR A MINIMUM OF 18” ROUND ALL MANHOLE LIDS AND 12” DEEP
5. MANHOLES SHALL BE GAS TIGHT WITH A MINIMUM OPENING DIMENSION OF TWENTY (20) INCHES
6. CONCRETE COLLAR, SAMPLE BOX FITTING AND ALL EXTERIOR PIPING SUPPLIED BY INSTALLER
7. A SOILS INSPECTION REPORT IS REQUIRED BY A STATE LICENSED GEOTECHNICAL SOILS ENGINEER. SUBGRADE AND ALL BACKFILL SHALL BE COMPACTED TO A MINIMUM OF 95% COMPACTION WHEN INSTALLED IN TRAFFIC AREA. WHEN INSTALLED OUTSIDE TRAFFIC AREAS, COMPACT TO 90% RELATIVE COMPACTION.

NOTE:

THE GREASE INTERCEPTOR SHALL BE SIZED USING THE CURRENT CALIFORNIA PLUMBING CODE

MINIMUM SIZE SHALL BE 750 GALLONS

MOULTON NIGUEL WATER DISTRICT

GREASE INTERCEPTOR
TANK WITH SAMPLE BOX

S-13
AUGUST 2024

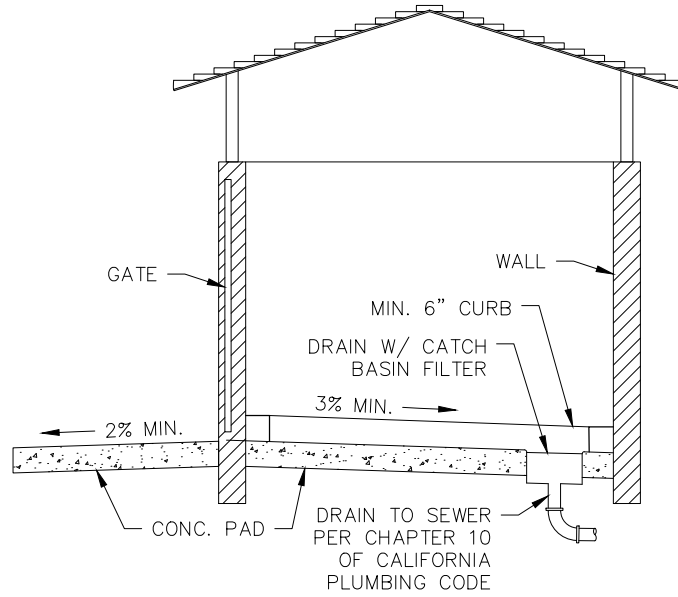

SECTION A-A

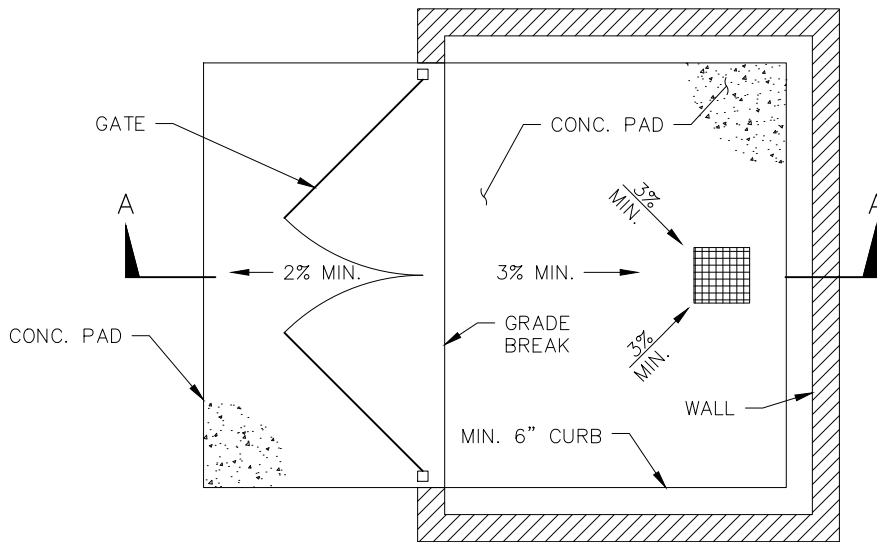

PLAN

NOTES:

1. CONSTRUCT TRASH ENCLOSURE SO THAT NO STORMWATER OR DEBRIS IS ALLOWED TO ENTER THE DISTRICT'S SEWER SYSTEM.
2. TRASH ENCLOSURE STRUCTURE PER CITY BUILDING DEPARTMENT.
3. ENCLOSURE DRAIN WITH CATCH BASIN FILTER.
4. CONSTRUCT GATE AT GRADE BREAK.

MOULTON NIGUEL WATER DISTRICT

TRASH ENCLOSURE

S-14
AUGUST 2024

Section VI

Approved Material List

APPROVED MATERIALS LIST

GENERAL

- A. Unless otherwise stated, all listed manufacturers and models shall allow for “or-equal” consideration per specification Section 01630.
- B. Manufacturers and models indicated as “No Exceptions” in the Plans and Specifications shall take precedence over those in this list.

SECTION 03300 CONCRETE

- A. Form Ties
 - 1. Burke Penta-Tie System
 - 2. Dayton Superior Snap-Ties
- B. Admixtures
 - 1. Sika Corporation
 - 2. BASF
 - 3. GCP
- C. Mechanical Couplers
 - 1. Dayton Superior Dowel Bar
 - 2. Erico Products Lenton Form Saver

SECTION 03461 PRECAST REINFORCED CONCRETE MANHOLES

- A. Precast Reinforced Concrete Products
 - 1. Jensen Precast
 - 2. Old Castle Precast
 - 3. Precon Products
- B. Cast Iron Frame and Covers
 - 1. Standard
 - a. Alhambra Foundry
 - b. Neenah Foundry
 - c. Long Beach Iron Works
 - d. South Bay Foundry

- C. Composite Manhole Frames and Covers
 - 1. GMI Composites
- D. Concrete Adhesive
 - 1. Sika Corporation

SECTION 03462 PRECAST CONCRETE VAULTS

- A. Precast Vaults and Meter Boxes
 - 1. J & R Products
 - 2. Jensen Precast
 - 3. Eisel Enterprises, Inc.
- B. Ladders
 - 1. Galvanized with ladderup – Alhambra A-3400
- C. Joint Sealing Compound
 - 1. Ram-Nek as manufactured by K.T. Snyder Company, Inc.
 - 2. ConSeal as manufactured by Concrete Sealants, Inc.
 - 3. EZ-Stik as manufactured by Press-Seal Gasket Corporation
- D. Waterproofing
 - 1. Grace Dehydratine 4

SECTION 03463 GREASE INTERCEPTORS

- A. Grease Interceptors
 - 1. Pro-Cast
 - 2. Jensen Precast

SECTION 09810 EPOXY COATING FOR SEWER MANHOLE REHABILITATION

- A. Coating
 - 1. Sauereisen Sewergard No. 210
 - 2. Warren Environmental S-301
 - 3. Quadex Structure Guard

- B. Repair materials
 - 1. Sauereisen Resurfacing Compound No. F-121
 - 2. Warren M-301 Epoxy Mastic
 - 3. CTS Cement Rapid Set Mortar Mix

SECTION 09900 PAINTING AND COATING

- A. Epoxy
 - 1. Amerlock 2 VOC
 - 2. Tnemec Series L69
 - 3. Carboline Carboguard 890 VOC
 - 4. Sherwin Williams Macropoxy 646-100
 - 5. ICI Paint, Devoe 235V
- B. Epoxy (for immersion in potable or recycled water)
 - 1. Tnemec Series L140
 - 2. Carboline Carboguard 890 VOC
 - 3. Sherwin Williams Macropoxy 646-100PW
- C. Urethane
 - 1. Amersfield VOC
 - 2. Tnemec Series 1095
 - 3. Carboline Carbothane 134 MC
 - 4. Sherwin Williams Sher-Loxane 800
 - 5. ICI Paint, Devoe 379H
- D. High-Solids Epoxy
 - 1. Tnemec Series 22
 - 2. Carboline Phenoline 341
- E. Sulfide-Resistant Epoxy
 - 1. Tnemec Series 435
 - 2. Carboline Plasite 4450
- F. Bituminous Mastic
 - 1. Northtown Company 50-HT
 - 2. Christy's HD50

SECTION 13110 DISSIMILAR METAL CONNECTIONS

- A. Insulating Flange Kits
 - 1. PSI Linebacker
- B. Insulating Bushings
 - 1. Northtown Company
- C. Casing Spacers
 - 1. GPT - C8G-2
- D. Casing End Seals
 - 1. GPT – type KT
- E. Wax Tape Coating System
 - 1. Trenton
- F. Wax Tape Primer
 - 1. Trenton

SECTION 13121 CORROSION PROTECTION

- A. Weld Cap Primer
 - 1. Royston Roybond Primer 747
- B. Weld Caps
 - 1. Royston Handy Cap
 - 2. Trenton

SECTION 15050 HOT TAP CONNECTIONS

- A. Tapping sleeves for taps smaller than the pipeline
 - 1. The Ford Meter Box Company SS
 - 2. JCM
 - a. 432 SS
 - b. 462 SS
 - 3. Mueller H-304SS
 - 4. Romac SST or SST II
 - 5. Smith-Blair 662-663 SS

- B. Tapping sleeves for size on size taps
 - 1. Mueller H-616
- C. Tapping sleeves onto 14-inch and larger ACP
 - 1. Mueller H-304

SECTION 15056 DUCTILE-IRON PIPE AND FITTINGS

- A. Pipe
 - 1. Pacific States Cast Iron Pipe Company
 - 2. U.S. Pipe
 - 3. American Pipe
- B. Push-On Joint Restraint Harness for Ductile Iron Pipe:
 - 1. EBAA Iron Megalug Series
 - 2. Smith Blair Bell-Lock
 - 3. Romac
- C. Fittings
 - 1. Tyler
 - 2. Trinity Valley
 - 3. Dayton
 - 4. Sigma
 - 5. Long Beach Iron
- D. Mechanical Joint Restraining System for Ductile Iron Pipe
 - 1. EBAA Iron Megalug
 - 2. Smith Blair MJ-Lock
 - 3. Romac RomoGrip
 - 4. The Ford Meter Box Company
- E. Mechanical Joint Restraining System for PVC Pipe
 - 1. EBAA Iron Megalug Series
 - 2. Smith Blair MJ-Lock
 - 3. Romac PVC RomoGrip
 - 4. The Ford Meter Box Company

- F. Plastic Film Wrap
 - 1. Polyken 900
 - 2. Scotch wrap 50
- G. Ceramic Epoxy Lining
 - 1. Induron Protecto 401
 - 2. Tnemec Perma-Shield PL Series 431
- H. Corrosion Guard
 - 1. Christy's CG-15 Corrosion Guard
 - 2. Trenton

SECTION 15057 COPPER, BRASS, AND BRONZE PIPE FITTINGS AND APPURTENANCES

- A. Copper Tubing and Fittings
 - 1. Mueller Industries
- B. Customer Service Valve
 - 1. Jones
 - 2. Mueller
 - 3. A.Y. McDonald
 - 4. The Ford Meter Box Company
- C. Corporation Stop
 - 1. Jones
 - 2. Mueller
 - 3. A.Y. McDonald
 - 4. The Ford Meter Box Company
- D. Angle Meter Stop
 - 1. Jones
 - 2. Mueller
 - 3. A.Y. McDonald
 - 4. The Ford Meter Box Company
- E. Service Saddle (for Ductile-Iron main)
 - 1. Jones
 - 2. Mueller
 - 3. A.Y. McDonald
 - 4. The Ford Meter Box Company

F. Service Saddles (for PVC main)

1. Jones
2. Mueller
3. A.Y. McDonald
4. The Ford Meter Box Company

G. Insulating Pipe

1. Pipeline Coating and Engineering Co., 1566 East Slauson Avenue, Los Angeles
2. Smith Blair
3. Pipe Seal and Insulator Company

SECTION 15064 PVC PRESSURE DISTRIBUTION PIPE

A. PVC Distribution Pipe

1. North American Pipe Corporation
2. Vinyltech
3. Certainteed
4. Diamond Plastics

B. Push-On Joint Restraint Harness for PVC Pipe:

1. EBAA Iron Megalug Series 1900
2. Smith Blair Bell-Lock
3. Romac

SECTION 15066 GRAVITY SEWER PIPELINES

A. PVC Pipe

1. Vinyltech
2. Diamond Plastics
3. Carlon

B. PVC Fittings

1. GPK Products

C. Vitrified-Clay Pipe and Fittings

1. Gladding McBean
2. Mission Clay Products

SECTION 15068 SEWER LATERALS

- A. Banded Flexible Saddle Wyes
 - 1. Fernco
- B. Banded Flexible Coupling
 - 1. Fernco

SECTION 15089 AIR VALVES

- A. Combination Valves $\leq 2''$
 - 1. ARI
- B. Combination Valves $> 2''$
 - 1. APCO
 - 2. Val-Matic
 - 3. Crispin
 - 4. ARI
- C. Air Valve Enclosure
 - 1. Armorcast
 - 2. Pipeline Products

SECTION 15100 MANUAL VALVES

- A. Metal Seated Gate Valves
 - 1. Mueller, Series A-2380
 - 2. Clow, Double Disc Gate Valve
 - 3. Kennedy Valve, Double Disc Gate Valve
- B. Butterfly Valves
 - 1. Pratt
 - 2. Dezurik
- C. Resilient Seated Gate Valves
 - 1. Clow RW 2639 and 2640
 - 2. American Flow Control Series 2500
 - 3. Kennedy Valve, AWWA C-509
 - 4. American AVK Co., Series 45 and 65
 - 5. Mueller Series A-2360

6. U.S. Pipe A-USP1

D. Valve Boxes

1. South Bay Foundry - 1208N WATER

SECTION 15139 FIRE HYDRANTS

A. Wet Barrel Fire Hydrants

1. Jones J-3710 8-hole Fire Hydrant P/C Safety Yellow
2. Clow Model 2050

B. Wet Barrel Fire “Super Hydrants”

1. Clow Model 2065

C. Break Off Check Valves

1. Jones J6000
2. Clow LBIW #400A

SECTION 15150 METERS

A. Customer Meters and Fire Service Bypass Meters (3/4-inch through 1-inch)

1. Sensus iPerl

B. Customer Meter (1-1/2 inch through 2 inch)

1. Kamstrup flowIQ 3101

C. Commercial Customer Meters (3-inch through 8-inch)

1. Sensus Omni Compound (C2)

D. Irrigation Customer Meters (3-inch through 8-inch) and Commercial Bypass Meters (2-inch)

1. Sensus Omni Turbo (T2)

E. Propeller Flowmeters

1. McCrometer

F. Magnetic Flowmeters

1. Toshiba

**SECTION 15151 POTABLE WATER, RECYCLED WATER, AND WASTEWATER FACILITIES
IDENTIFICATION**

- A. Warning Tape and Pipe Sleeves
 - 1. Griffolyn Company, Inc.
 - 2. Terra Tape, Division of Reef Industries
 - 3. T. Christy Enterprises, Inc.
- B. Witness Markers
 - 1. Carsonite Water line Markers

SECTION 15162 PIPE COUPLINGS AND ADAPTERS

- A. Sleeve-Type Couplings
 - 1. Baker
 - 2. Romac
 - 3. Smith-Blair
- B. Restrained Sleeve-Type Couplings
 - 1. Ebaa Iron
 - 2. Romac
 - 3. Smith-Blair
 - 4. Hymax
- C. Restrained One-Piece Coupling
 - 1. Romac

SECTION 15170 WALL AND SLAB PENETRATIONS

- A. Wall Pipe Modular Seals
 - 1. GPT Industries

SECTION 15300 AUTOMATIC CONTROL VALVES

- A. Check Valves
 - 1. Cla-Val model 81G-02KC with X101 Valve Position Indicator (installed by valve manufacturer)
 - 2. Singer model 106-HC

- B. Solenoid Control Valves
 - 1. Cla-Val model 136G-03 YBCSFKC with Limit Switch Assembly Model X105LCW (installed by valve manufacturer)
 - 2. Singer model 106-2SC-PCO
- C. Pressure Reducing Valves
 - 1. Cla-Val model 90G-01YBKC (90G-01YSFC for valves 3 inches and smaller), with X101 Valve Position Indicator (installed by valve manufacturer)
 - 2. Singer model 106-PR
- D. Pressure Relief Valves
 - 1. Cla-Val model 50G-01SBKC with Limit Switch Assembly Model X105LOW (installed by valve manufacturer)
 - 2. Singer model 106-BPC
- E. Surge Anticipator Valves
 - 1. Cla-Val model 52G-01BKC with Limit Switch Assembly Model X105LOW (installed by valve manufacturer)
 - 2. Singer model 106-RPS-L&H
- F. Pump Controller Valves
 - 1. Cla-Val model 60G-11 BKC with Limit Switch Assembly Model X105LCW (installed by valve manufacturer)
 - 2. Singer model 106-PG-BPC
- G. Altitude Valves
 - 1. Cla-Val model 210-01 with X-101 position indicator
 - 2. Singer model 106-A-Type 3 with X-107 position indicator

PIPE CRADDLE

- A. Grinnel No. 264

ELECTRICAL COMPONENTS

- A. Motors
 - 1. U.S. Motors
 - 2. Baldor – Reliance
 - 3. WEG

- B. Automatic Transfer Switches
 - 1. ASCO, 940 Series
- C. Electric Actuators
 - 1. Rotork
 - 2. AUMA
- D. Motor Control Centers and Drives
 - 1. Allen-Bradley (no exceptions)

INSTRUMENTATION

- A. Pressure Transmitters
 - 1. Rosemount, 2051 Smart
- B. Level Transmitter
 - 1. Rosemount, 5300
 - 2. Multitrode Level Probe
- C. Gas Detectors
 - 1. MSA
- D. Pump Control Panels
 - 1. FW Murphy
- E. Programmable Logic Controllers
 - 1. Allen-Bradley (no exceptions)