

TABLE OF CONTENTS
STANDARD DRAWINGS
FOR
RECYCLED WATER IRRIGATION

<u>DWG NO.</u>	<u>DWG TITLE</u>
IRR-1	AIR GAP
IRR-2	POC ASSEMBLY
IRR-3	WYE STRAINER
IRR-4	BASKET STRAINER
IRR-5	PRESSURE REGULATOR
IRR-6	MASTER VALVE
IRR-7	FLOW SENSOR
IRR-8	REMOTE CONTROL VALVE
IRR-9	REMOTE CONTROL VALVE ON GRADE
IRR-10	REMOTE CONTROL VALVE - DRIP
IRR-11	REMOTE CONTROL VALVE - DRIP ON GRADE
IRR-12	ISOLATION VALVE
IRR-13	ISOLATION VALVE ON GRADE
IRR-14	QUICK COUPLER
IRR-15	QUICK COUPLER ON GRADE
IRR-16	AIR RELIEF VALVE
IRR-17	AIR RELIEF VALVE ON GRADE
IRR-18	POP-UP SPRAY HEAD
IRR-19	POP-UP SPRAY HEAD WITH DRIP
IRR-20	POP-UP SPRAY HEAD TOE OF SLOPE
IRR-21	SHRUB SPRAY ON RISER
IRR-22	POP-UP ROTOR
IRR-23	POP-UP ROTOR WITH DRIP
IRR-24	POP-UP ROTOR TOE OF SLOPE
IRR-25	SHRUB ROTOR ON RISER
IRR-26	IRRIGATION LAYOUT
IRR-27	TREE IRRIGATION
IRR-28	INLINE DRIP LAYOUT
IRR-29	INLINE DRIP MEDIAN / PARKWAY LAYOUT
IRR-30	INLINE DRIP PVC HEADER
IRR-31	DRIP FLUSH VALVE
IRR-32	DRIP OPERATION INDICATOR
IRR-33	DRIP AIR RELIEF

TABLE OF CONTENTS
STANDARD DRAWINGS
FOR
RECYCLED WATER IRRIGATION

<u>DWG NO.</u>	<u>DWG TITLE</u>
IRR-34	PIPE TRENCHING
IRR-35	PIPES UNDER PAVING
IRR-36	TERRACE DRAIN CROSSING
IRR-37	THRUST BLOCKS
IRR-38	IDENTIFICATION TAGS AND LABELS
IRR-39	RECYCLED WATER IDENTIFICATION SIGN
IRR-40	SEPARATION OF DW / RW MAINLINES
IRR-41	PIPE STABILIZER ON GRADE
IRR-42	BRANDING GUIDE
IRR-43	VALVE BOX LAYOUT
IRR-44	VALVE BOX ON SLOPE
IRR-45	RAIN SENSOR
IRR-46	MWELO COMPLIANCE NOTES
IRR-47	RECYCLED WATER STANDARD NOTES
IRR-48	PLAN SHEET BLOCKS
W-3	STANDARD 1-1/2" & 2" WATER SERVICE

NOTES:

1. THE TERM 'AIR GAP' SHALL MEAN A PHYSICAL SEPARATION BETWEEN THE FREE FLOWING DISCHARGE END OF A WATER SUPPLY PIPELINE AND AN OPEN OR NON-PRESSURE RECEIVING VESSEL, AND "APPROVED AIR GAP" SHALL BE AT LEAST DOUBLE THE DIAMETER OF THE SUPPLY PIPE MEASURED VERTICALLY ABOVE THE OVERFLOW RIM OF THE VESSEL - IN NO CASE LESS THAN 1 INCH.
2. PIPING SHALL BE PERMANENTLY INSTALLED.
3. ATTACH RECYLED WATER IDENTIFICATION LABELS AND TAGS TO PIPING STORAGE TANKS AND VEHICLES AS DIRECTED BY MNWD. (SEE DETAIL IRR-38)

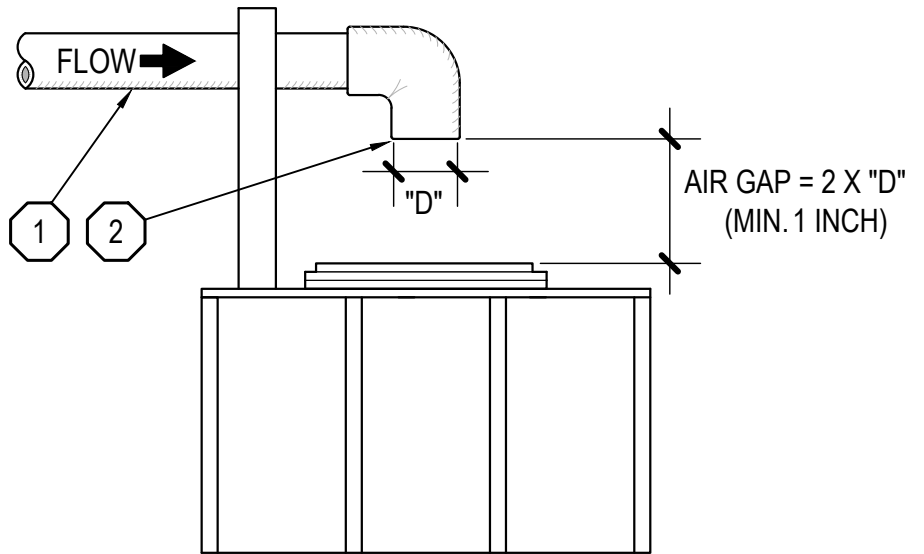

AIR GAP

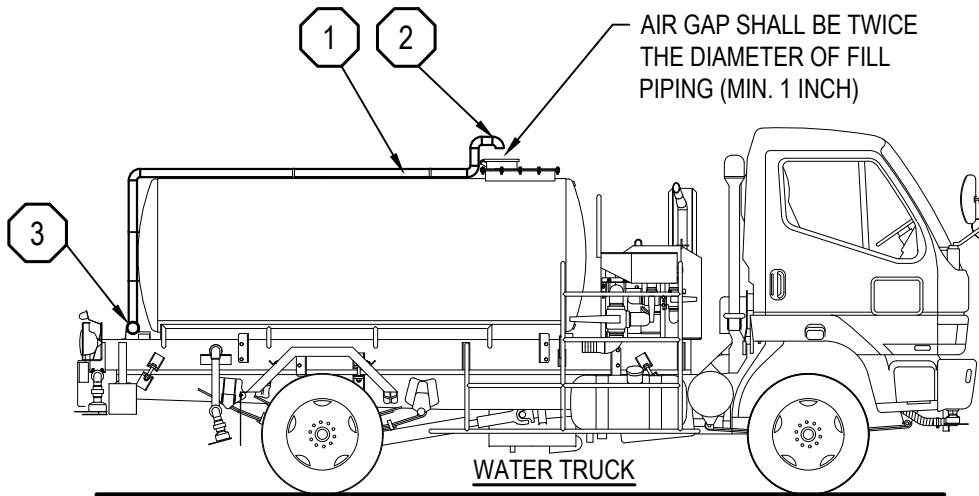

WATER TRUCK

1 SUPPLY PIPE

2 OUTLET OF PERMANENTLY ATTACHED FILL PIPE WITH 'AIR GAP'

3 INLET/ HOSE WATER CONNECTION

MOULTON NIGUEL WATER DISTRICT

AIR GAP

IRR-1

NOTES:

1. INSTALL BRASS PIPING UP TO INLET SIDE OF MASTER VALVE.
2. WRAP ALL BRASS PIPING WITH 10-MIL BUTYL RUBBER WITH POLYETHYLENE BACKING PIPE WRAP TAPE OVER PRIMER.
3. IDENTIFY RECYCLED WATER PIPING BY ATTACHING 3" WIDE PURPLE IDENTIFICATION TAPE (SEE DETAIL IRR-38).
4. INSTALL WATER METER, METER BOX, BALL VALVE AND METER TELEMTRY PER MNWD STANDARD SPECIFICATIONS FOR CONSTRUCTION OF DOMESTIC WATER, SEWER AND RECYCLED WATER FACILITIES, (SEE DETAIL W-3).
5. ATTACH PURPLE RECYCLED WATER IDENTIFICATION TAG AS DIRECTED ON RECYCLED SYSTEM TO WATER METER (SEE DETAIL IRR-38).
6. IF BOOSTER PUMP IS NOT INSTALLED IN CLOSE PROXIMITY TO THE WATER METER, CONTACT MNWD FOR SPECIFIC INSTALLATION INSTRUCTIONS FOR ALL APPURTENANCES.
7. ATTACH IDENTIFICATION TAPE TO ALL BELOW GRADE BRASS PIPING AS DIRECTED BY THE DISTRICT.

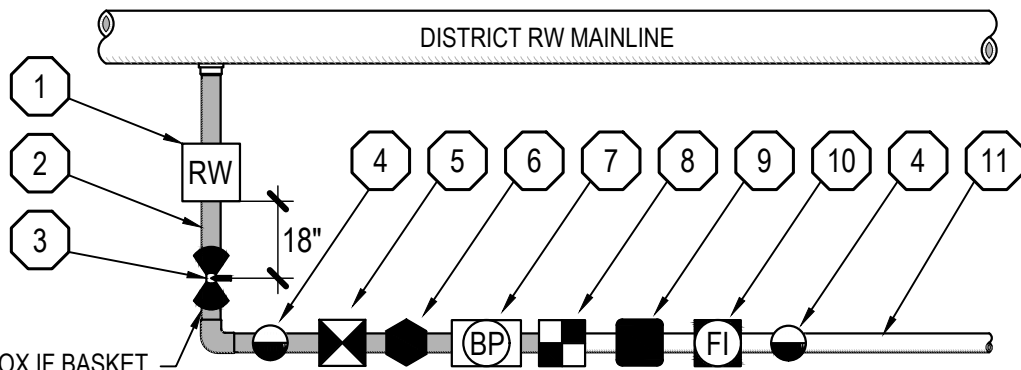

LOCATE IN VALVE BOX IF BASKET STRAINER IS USED, OR INSTALL ABOVE GROUND BEFORE WYE (SEE DETAIL IRR-3 OR IRR-4).

- | | |
|--|---|
| <ul style="list-style-type: none"> 1 RECYCLED WATER METER BOX CONTAINING: ANGLE STOP, METER, AND BALL VALVE 2 SCHEDULE 40 BRASS PRESSURE MAINLINE 3 FOR RECYCLED WATER SYSTEMS INSTALL A LINE SIZE BRASS RESILIENT SEAT BALL VALVE 18" MIN FROM METER BOX 4 QUICK COUPLING VALVE - ACME THREAD W/PURPLE LOCKING COVER 5 WYE STRAINER OR BASKET STRAINER WITH 80 MESH MONEL SCREEN 6 PRESSURE REGULATOR - IF REQUIRED | <ul style="list-style-type: none"> 7 BOOSTER PUMP - IF REQUIRED 8 MASTER VALVE 9 FLOW SENSOR 10 FERTILIZER INJECTOR - IF REQUIRED 11 IRRIGATION MAINLINE |
|--|---|

NOTES:

1. USE SCHEDULE 40 BRASS PIPE FOR ALL PIPING BELOW GRADE FROM METER TO INLET SIDE OF MASTER VALVE
2. ALL THREADED CONNECTIONS TO USE NON-HARDENING THREAD SEALANT
3. ALL BURIED BRASS PIPE SHALL BE WRAPPED USING PIPE WRAP TAPE: 10-MIL BUTYL RUBBER WITH POLYETHYLENE BACKING OVER PRIMER.
4. ATTACH PURPLE RECYCLED IDENTIFICATION LABELS AND TAGS AS DIRECTED BY MNWD (SEE DETAIL IRR-38)
5. IDENTIFY RECYCLED WATER PIPING BY ATTACHING 3" WIDE PURPLE IDENTIFICATION TAPE TO ALL BELOW GRADE PIPING (SEE DETAIL IRR-38)

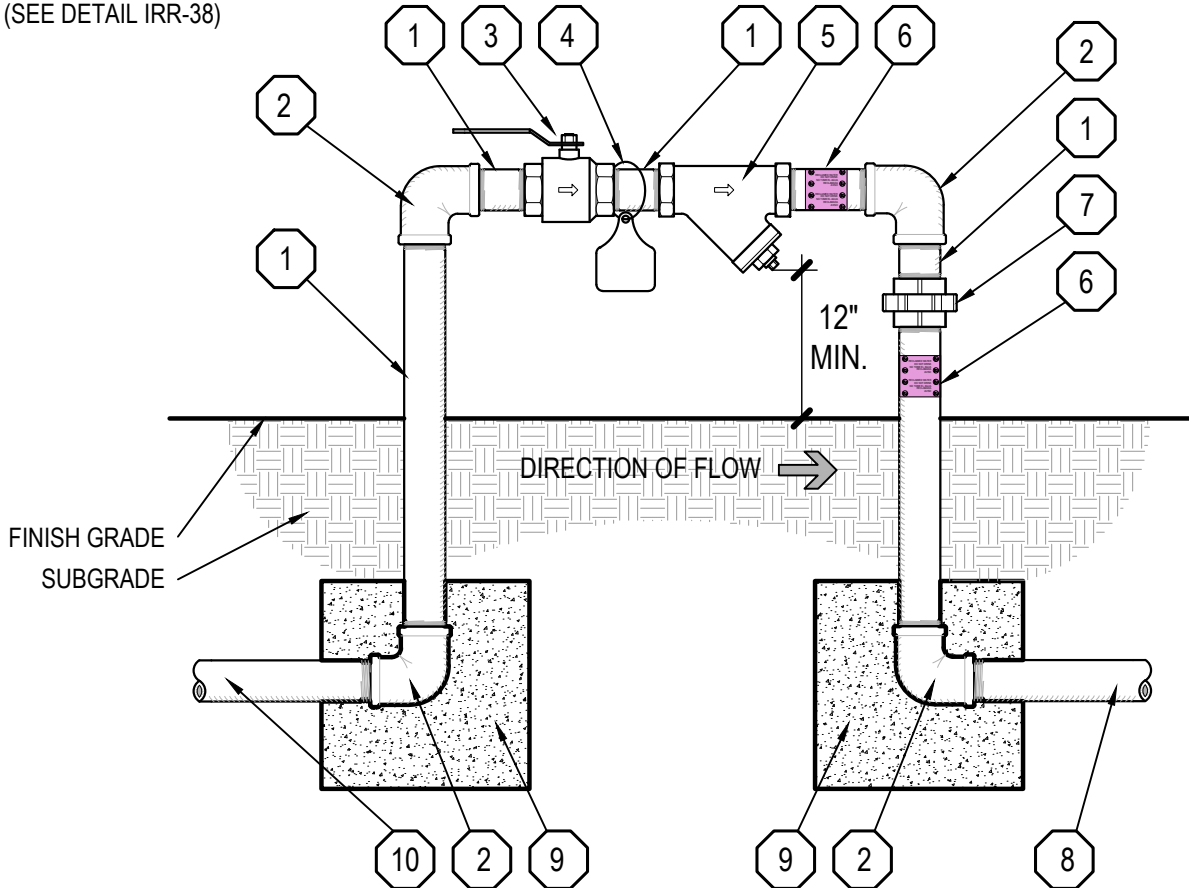

- ① SCHEDULE 40 BRASS NIPPLE - INLET SIZE - LENGTH AS REQUIRED
- ② SCHEDULE 40 BRASS ELL - INLET SIZE
- ③ BRASS FULL PORT BALL VALVE - LINE SIZE
- ④ WATER IDENTIFICATION TAG - (SEE DETAIL IRR-38)
- ⑤ WYE STRAINER WITH 80 MESH MIN. MONEL SCREEN, BRASS PLUG REQUIRED - LINE SIZE

- ⑥ SCHEDULE 40 BRASS NIPPLE WITH IDENTIFICATION LABEL - INLET SIZE - LENGTH AS REQUIRED
- ⑦ SCHEDULE 40 BRASS UNION
- ⑧ SCHEDULE 40 BRASS PRESSURE SUPPLY LINE TO IRRIGATION SYSTEM
- ⑨ 12" X 12" CONCRETE STABILIZER
- ⑩ SCHEDULE 40 BRASS PRESSURE SUPPLY LINE FROM WATER METER

MOULTON NIGUEL WATER DISTRICT

WYE STRAINER

IRR-3

NOTES:

1. USE SCHEDULE 40 BRASS PIPE FOR ALL PIPING BELOW GRADE FROM METER TO INLET SIDE OF MASTER VALVE
2. ALL THREADED CONNECTIONS TO USE NON-HARDENING THREAD SEALANT
3. ALL BURIED BRASS PIPE SHALL BE WRAPPED USING PIPE WRAP TAPE: 10-MIL BUTYL RUBBER WITH POLYETHYLENE BACKING OVER PRIMER.
4. IDENTIFY RECYCLED WATER PIPING BY ATTACHING 3" WIDE PURPLE IDENTIFICATION TAPE TO ALL BELOW GRADE PIPING (SEE DETAIL IRR-38)

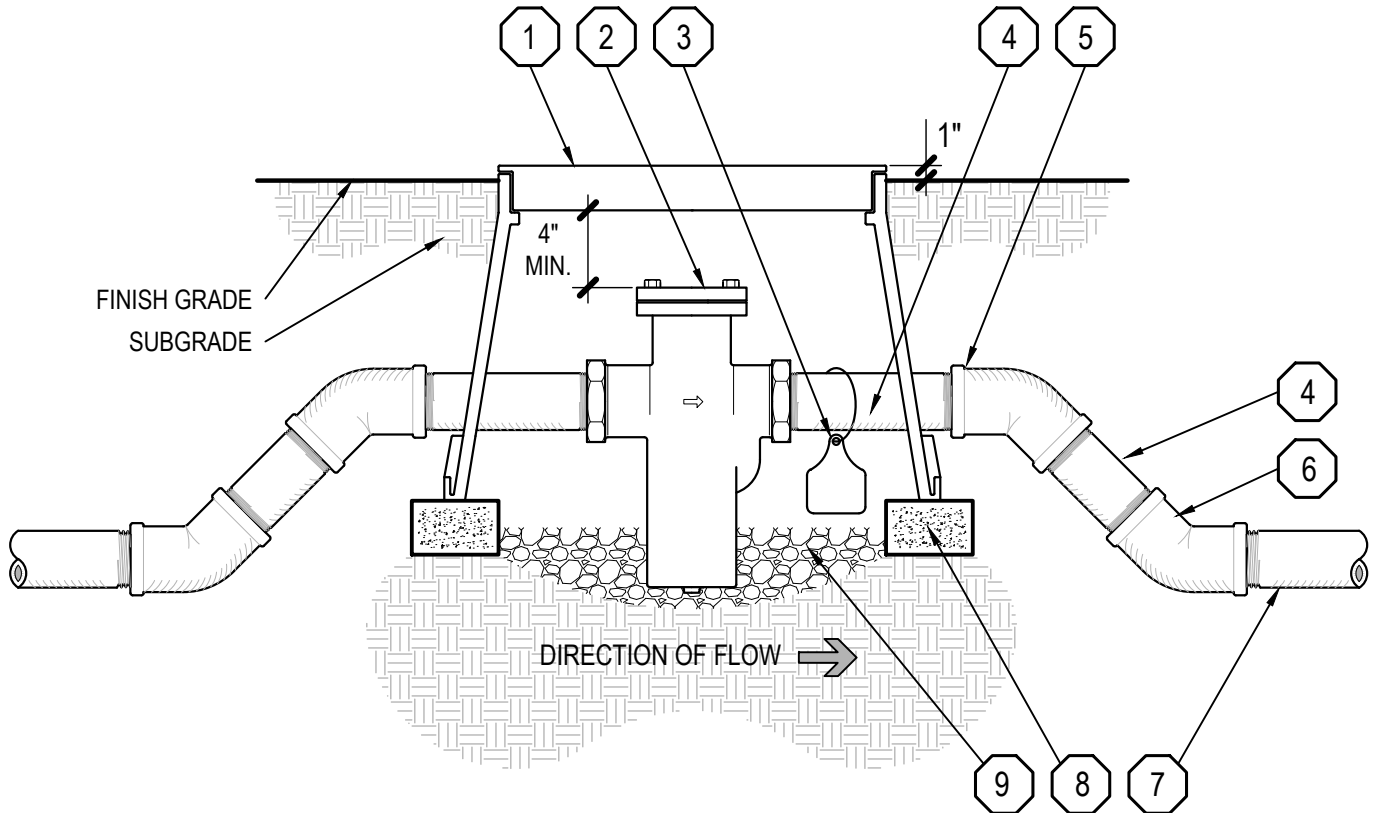

1 LOCKING RECTANGULAR VALVE BOX
(SEE DETAIL IRR-42)

2 BASKET STRAINER

3 WATER IDENTIFICATION TAG - (SEE DETAIL IRR-38)

4 SCHEDULE 40 BRASS NIPPLE - INLET SIZE - LENGTH TO CLEAR VALVE BOX / LENGTH AS REQUIRED

5 SCHEDULE 40 BRASS 45° ELL WITH BUSHING TO ADAPT PIPE TO INLET SIZE OF BASKET STRAINER

6 SCHEDULE 40 BRASS 45° ELL - LINE SIZE

7 SCHEDULE 40 BRASS PRESSURE MAINLINE

8 BRICK SUPPORT - FOUR REQUIRED

9 3/4" CRUSHED GRAVEL - 6" DEPTH

MOULTON NIGUEL WATER DISTRICT

BASKET STRAINER

IRR-4

NOTES:

1. USE SCHEDULE 40 BRASS PIPE FOR ALL PIPING BELOW GRADE FROM METER TO INLET SIDE OF MASTER VALVE
2. ALL THREADED CONNECTIONS TO USE NON-HARDENING THREAD SEALANT
3. ALL BURIED BRASS PIPE SHALL BE WRAPPED USING PIPE WRAP TAPE: 10-MIL BUTYL RUBBER WITH POLYETHYLENE BACKING OVER PRIMER.
4. IDENTIFY RECYCLED WATER PIPING BY ATTACHING 3" WIDE PURPLE IDENTIFICATION TAPE TO ALL BELOW GRADE PIPING (SEE DETAIL IRR-38)
5. SET PRESSURE REGULATOR PRESSURE SETTING PER PLAN

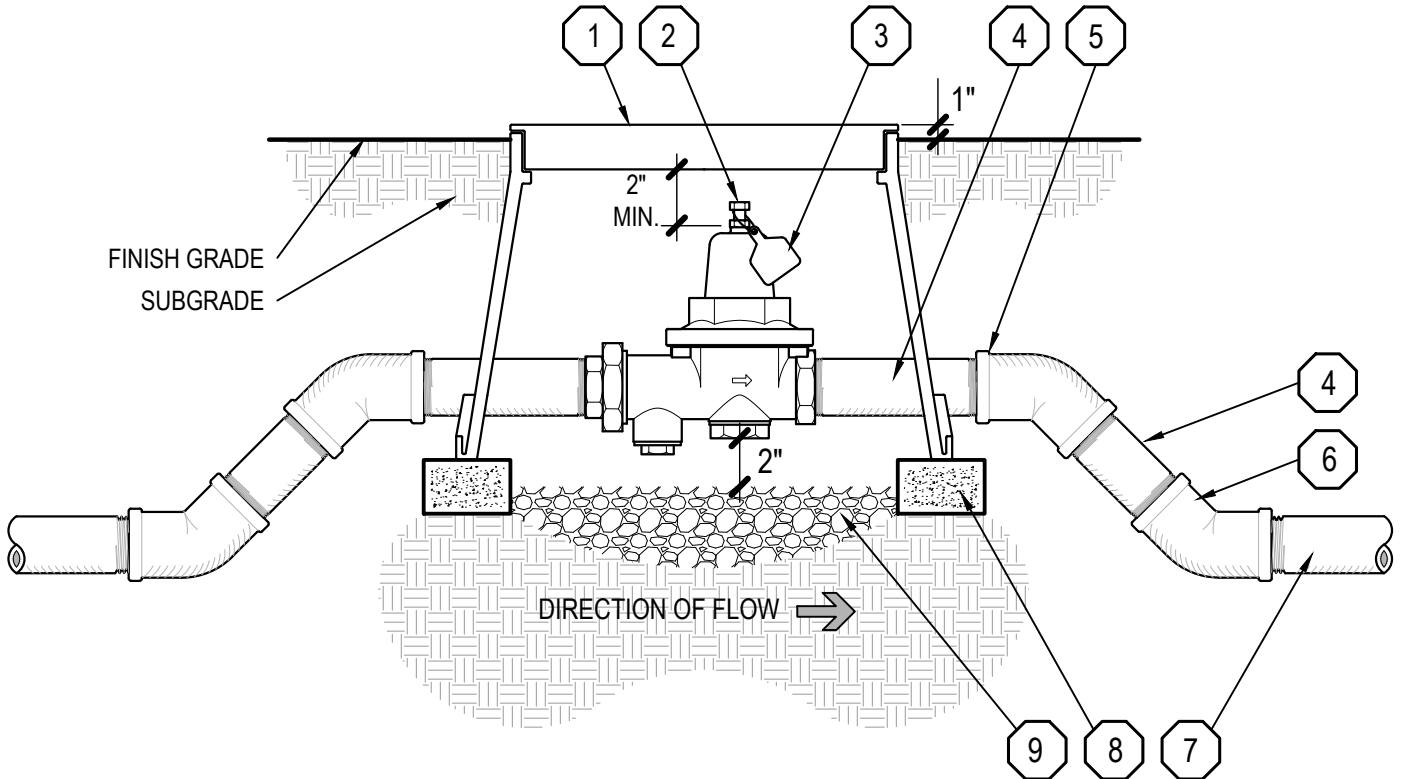

- | | |
|---|--|
| <p>1 LOCKING RECTANGULAR VALVE BOX WITH EXTENSION (SEE DETAIL IRR-42)</p> <p>2 BRASS PRESSURE REGULATOR</p> <p>3 WATER IDENTIFICATION TAG - (SEE DETAILS IRR-38)</p> <p>4 SCHEDULE 40 BRASS NIPPLE - INLET SIZE - LENGTH TO CLEAR VALVE BOX / LENGTH AS REQUIRED</p> <p>5 SCHEDULE 40 BRASS 45° ELL WITH BUSHING TO ADAPT PIPE TO INLET SIZE OF BASKET STRAINER</p> | <p>6 SCHEDULE 40 BRASS 45° ELL - LINE SIZE</p> <p>7 SCHEDULE 40 BRASS PRESSURE MAINLINE</p> <p>8 BRICK SUPPORT - FOUR REQUIRED</p> <p>9 3/4" CRUSHED GRAVEL - 6" DEPTH</p> |
|---|--|

MOULTON NIGUEL WATER DISTRICT
PRESSURE REGULATOR

IRR-5

NOTES:

1. USE SCHEDULE 40 BRASS PIPE FOR ALL PIPING BELOW GRADE FROM METER TO INLET SIDE OF MASTER VALVE
2. ALL THREADED CONNECTIONS TO USE NON-HARDENING THREAD SEALANT
3. ALL BURIED BRASS PIPE SHALL BE WRAPPED USING PIPE WRAP TAPE: 10-MIL BUTYL RUBBER WITH POLYETHYLENE BACKING OVER PRIMER.
4. IDENTIFY RECYCLED WATER PIPING BY ATTACHING 3" WIDE PURPLE IDENTIFICATION TAPE TO ALL BELOW GRADE PIPING (SEE DETAIL IRR-38)

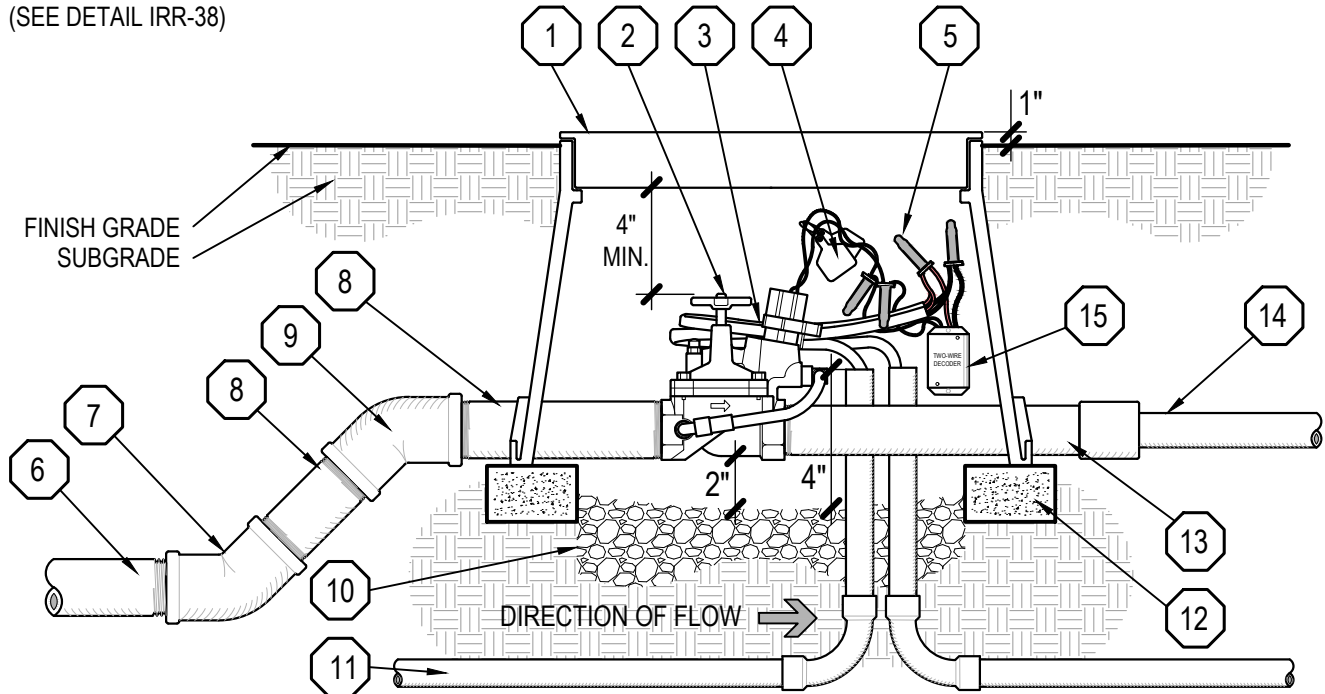

- | | |
|---|---|
| <p>1 LOCKING RECTANGULAR VALVE BOX (SEE DETAIL IRR-42)</p> <p>2 MASTER VALVE</p> <p>TWO-WIRE - TWO-WIRE CABLE WITH 36" MINIMUM EXPANSION LOOP</p> <p>CONVENTIONAL WIRE - 14 AWG BLUE AND YELLOW MASTER VALVE WIRE WITH 36" MINIMUM EXPANSION COIL</p> <p>3 STATION ID TAG AND WATER IDENTIFICATION TAG - LOCATE ON SOLENOID WIRES - (SEE DETAIL IRR-38)</p> <p>4 WATERPROOF WIRE CONNECTORS</p> <p>5 SCHEDULE 40 BRASS PRESSURE MAINLINE</p> <p>6 SCHEDULE 40 BRASS 45° ELL - LINE SIZE</p> | <p>7 SCHEDULE 40 BRASS NIPPLE - INLET SIZE - LENGTH TO CLEAR VALVE BOX / LENGTH AS REQUIRED</p> <p>8 SCHEDULE 40 BRASS 45° ELL WITH BUSHING TO ADAPT PIPE TO INLET SIZE OF MASTER VALVE</p> <p>9 3/4" CRUSHED GRAVEL - 6" DEPTH</p> <p>10 1-1/4" WIRE CONDUIT WITH SWEEPS IN AND OUT OF EACH VALVE BOX</p> <p>11 BRICK SUPPORTS - FOUR REQUIRED</p> <p>12 SCHEDULE 80 PVC TOE NIPPLE WITH SLIP COUPLING AND BUSHING TO ADAPT PIPE TO PRESSURE MAINLINE SIZE</p> <p>13 PRESSURE MAINLINE - SIZE OF PIPE TO MATCH FLOW SENSOR (IF SPECIFIED)</p> <p>14 TWO-WIRE MASTER VALVE DECODER - AS REQUIRED FOR TWO-WIRE SYSTEMS</p> |
|---|---|

MOULTON NIGUEL WATER DISTRICT

MASTER VALVE

IRR-6

NOTES:

1. INSTALL FLOW SENSOR PER MANUFACTURER SPECIFICATIONS

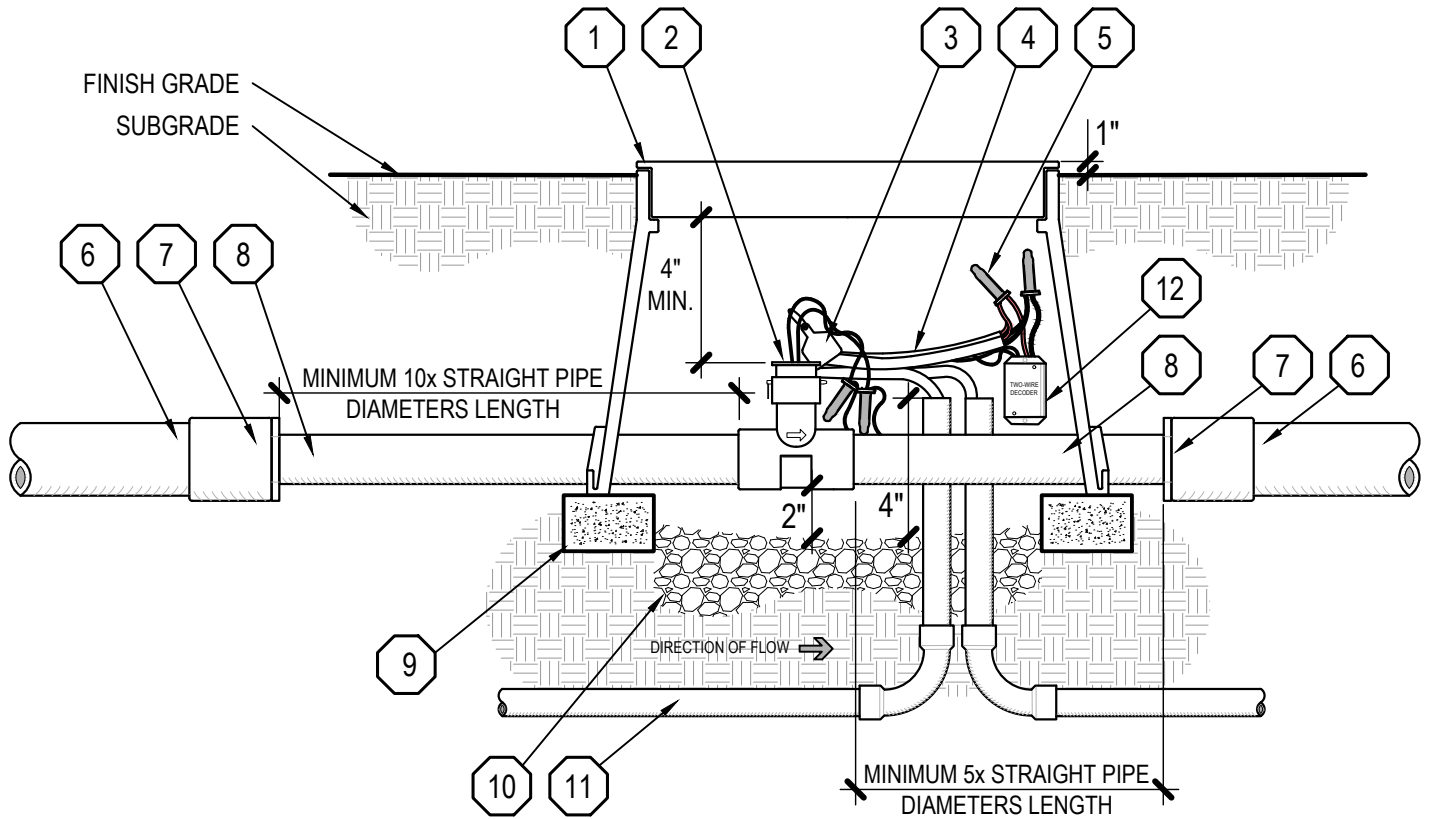

- | | |
|---|--|
| <p>1 LOCKING RECTANGULAR VALVE BOX (SEE DETAIL IRR-42)</p> <p>2 FLOW SENSOR</p> <p>3 WATER IDENTIFICATION TAG - (SEE DETAIL IRR-38)</p> <p>4 TWO-WIRE - TWO-WIRE CABLE WITH 36" MINIMUM EXPANSION LOOP
CONVENTIONAL WIRE - FLOW SENSOR CABLE 36" MINIMUM EXPANSION COIL</p> <p>5 WATERPROOF WIRE CONNECTORS</p> <p>6 PRESSURE MAINLINE PIPE</p> | <p>7 SCHEDULE 80 PVC SLIP COUPLING WITH BUSHING TO ADAPT PIPE TO FLOW SENSOR SIZE</p> <p>8 SLIP FLOW SENSOR - PRESSURE MAINLINE PIPE
THREADED FLOW SENSOR - SCHEDULE 80 PVC TOE NIPPLE SIZED TO MATCH FLOW SENSOR - LENGTH AS REQUIRED</p> <p>9 BRICK SUPPORTS - FOUR REQUIRED</p> <p>10 3/4" CRUSHED GRAVEL - 6" DEPTH</p> <p>11 1-1/4" WIRE CONDUIT WITH SWEEPS IN AND OUT OF EACH VALVE BOX</p> <p>12 TWO-WIRE FLOW SENSOR DECODER - AS REQUIRED FOR TWO-WIRE SYSTEMS</p> |
|---|--|

MOULTON NIGUEL WATER DISTRICT

FLOW SENSOR

IRR-7

NOTES:

1. ALL THREADED CONNECTIONS TO USE NON-HARDENING THREAD SEALANT

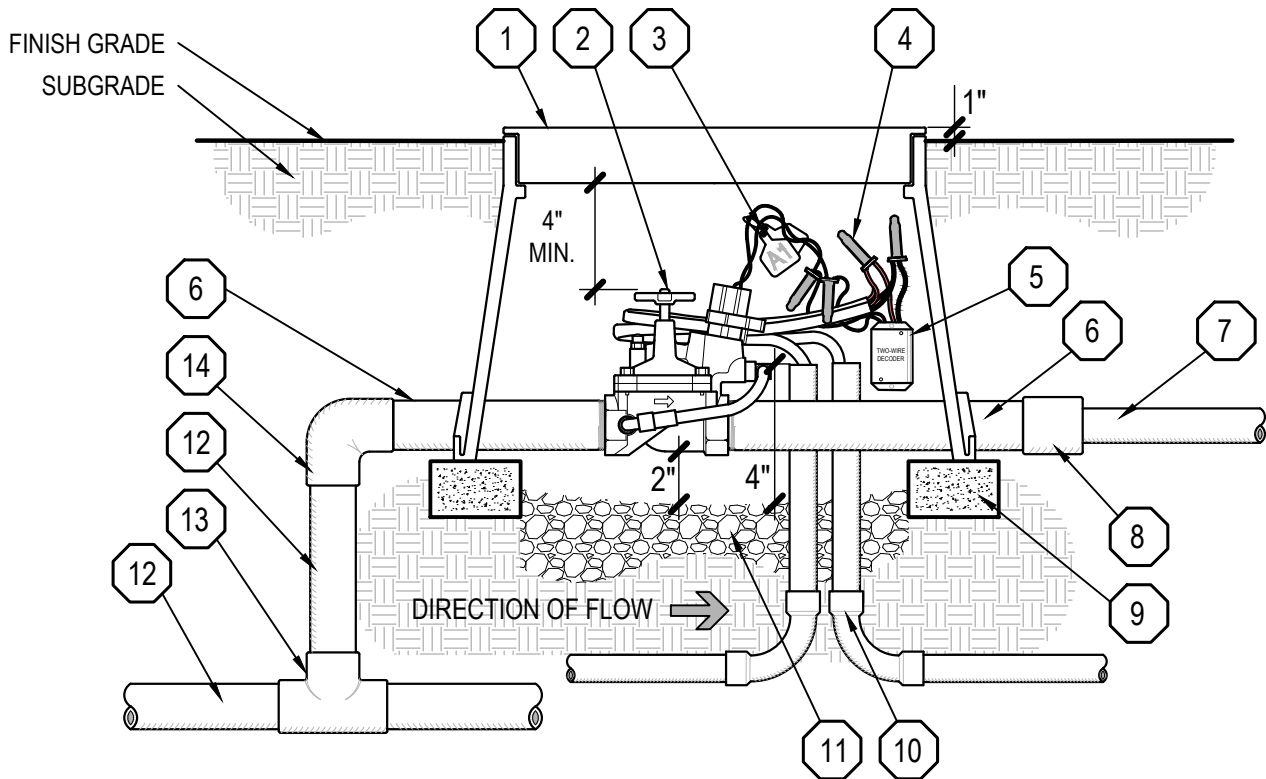

- | | |
|--|--|
| <p>1 LOCKING RECTANGULAR VALVE BOX (SEE DETAIL IRR-42)</p> <p>2 REMOTE CONTROL VALVE</p> <p>3 STATION ID TAG AND WATER IDENTIFICATION TAG - LOCATE ON SOLENOID WIRES - (SEE DETAIL IRR-38)</p> <p>TWO-WIRE - TWO-WIRE CABLE WITH 36" MINIMUM EXPANSION LOOP</p> <p>4 CONVENTIONAL WIRE - VALVE WIRE AND COMMON WIRE WITH 36" MINIMUM EXPANSION COIL INCLUDE WATERPROOF WIRE CONNECTORS FOR ALL WIRE CONNECTIONS</p> <p>5 TWO-WIRE DECODER - AS REQUIRED FOR TWO-WIRE SYSTEMS</p> <p>6 SCHEDULE 80 PVC TOE NIPPLE - LENGTH TO CLEAR VALVE BOX</p> | <p>7 LATERAL PIPE</p> <p>8 SLIP COUPLING - LATERAL FITTING WITH BUSHING TO ADAPT PIPE TO LATERAL SIZE</p> <p>9 BRICK SUPPORTS - FOUR REQUIRED</p> <p>10 1-1/4" TWO-WIRE CABLE CONDUIT WITH SWEEPS IN AND OUT OF EACH VALVE BOX - FOR TWO-WIRE SYSTEMS</p> <p>11 3/4" CRUSHED GRAVEL - 6" DEPTH</p> <p>12 PRESSURE MAINLINE PIPE</p> <p>13 SCHEDULE 80 PVC PRESSURE MAINLINE FITTING - SLIP TEE OR ELL</p> <p>14 SCHEDULE 80 PVC SLIP ELL WITH BUSHING TO ADAPT PIPE TO INLET SIZE OF VALVE</p> |
|--|--|

MOULTON NIGUEL WATER DISTRICT

REMOTE CONTROL VALVE

IRR-8

NOTES:

1. ALL THREADED CONNECTIONS TO USE NON-HARDENING THREAD SEALANT

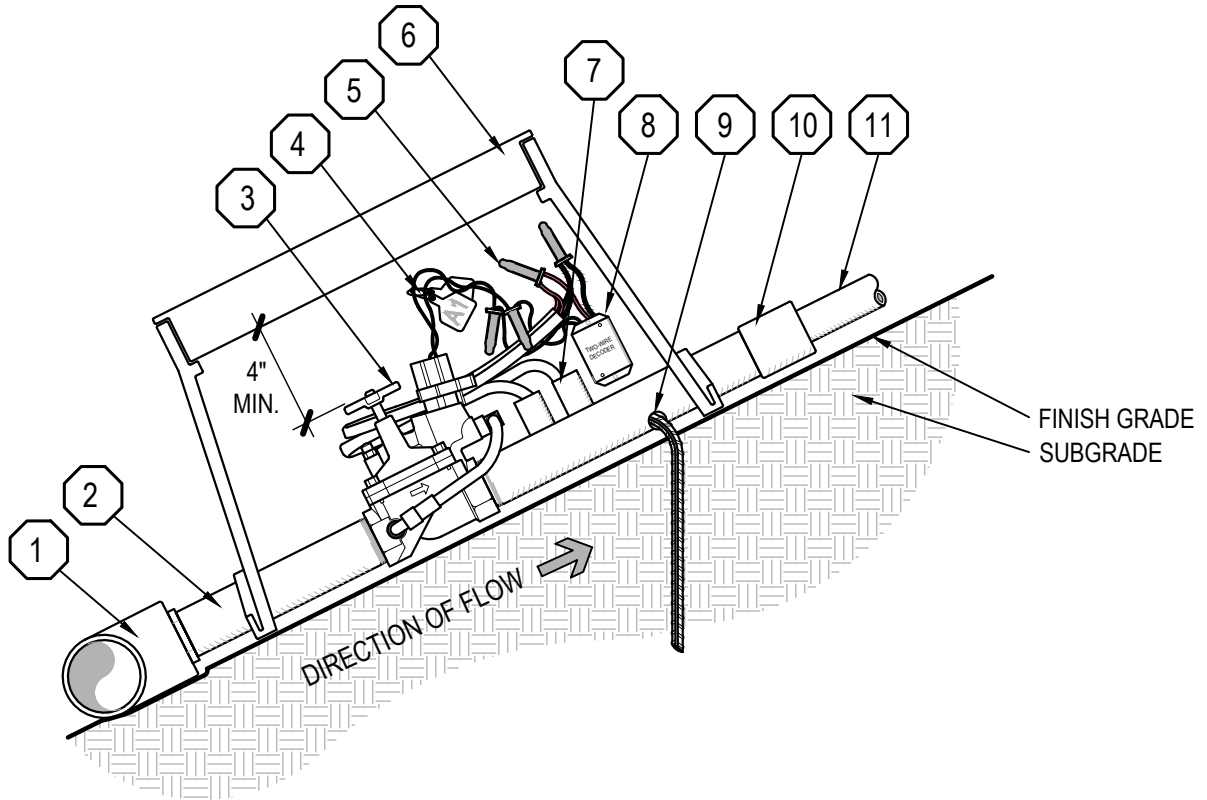

- | | |
|--|--|
| <p>1 GALVANIZED MAINLINE TEE OR ELL FITTING WITH THREADED REDUCER BUSHING</p> <p>2 SCHEDULE 40 GALVANIZED STEEL NIPPLE - INLET SIZE, LENGTH TO CLEAR VALVE BOX</p> <p>3 REMOTE CONTROL VALVE</p> <p>4 STATION ID TAG AND WATER IDENTIFICATION TAG - LOCATE ON SOLENOID WIRES - (SEE DETAIL IRR-38)</p> <p>5 TWO-WIRE - TWO-WIRE CABLE WITH 36" MINIMUM EXPANSION LOOP
CONVENTIONAL WIRE - VALVE WIRE AND COMMON WIRE WITH 36" MINIMUM EXPANSION COIL INCLUDE WATERPROOF WIRE CONNECTORS FOR ALL WIRE CONNECTIONS</p> | <p>6 LOCKING RECTANGULAR VALVE BOX (SEE DETAIL IRR-42)</p> <p>7 1-1/4" TWO-WIRE CABLE CONDUIT WITH SWEEPS IN AND OUT OF EACH VALVE BOX - FOR TWO-WIRE SYSTEMS</p> <p>8 TWO-WIRE DECODER - AS REQUIRED FOR TWO-WIRE SYSTEMS</p> <p>9 #4 REBAR - MINIMUM 18" LENGTH - INSTALL LONG END ON INSIDE OF BOX THROUGH 1" HOLE IN THE SIDE OF BOX</p> <p>10 SCHEDULE 40 UVR SLIP COUPLING - LATERAL FITTING WITH BUSHING TO ADAPT PIPE TO LATERAL SIZE</p> <p>11 SCHEDULE 40 UVR LATERAL PIPE</p> |
|--|--|

MOULTON NIGUEL WATER DISTRICT
REMOTE CONTROL VALVE ON GRADE

IRR-9

NOTES:

1. ALL THREADED CONNECTIONS TO USE NON-HARDENING THREAD SEALANT

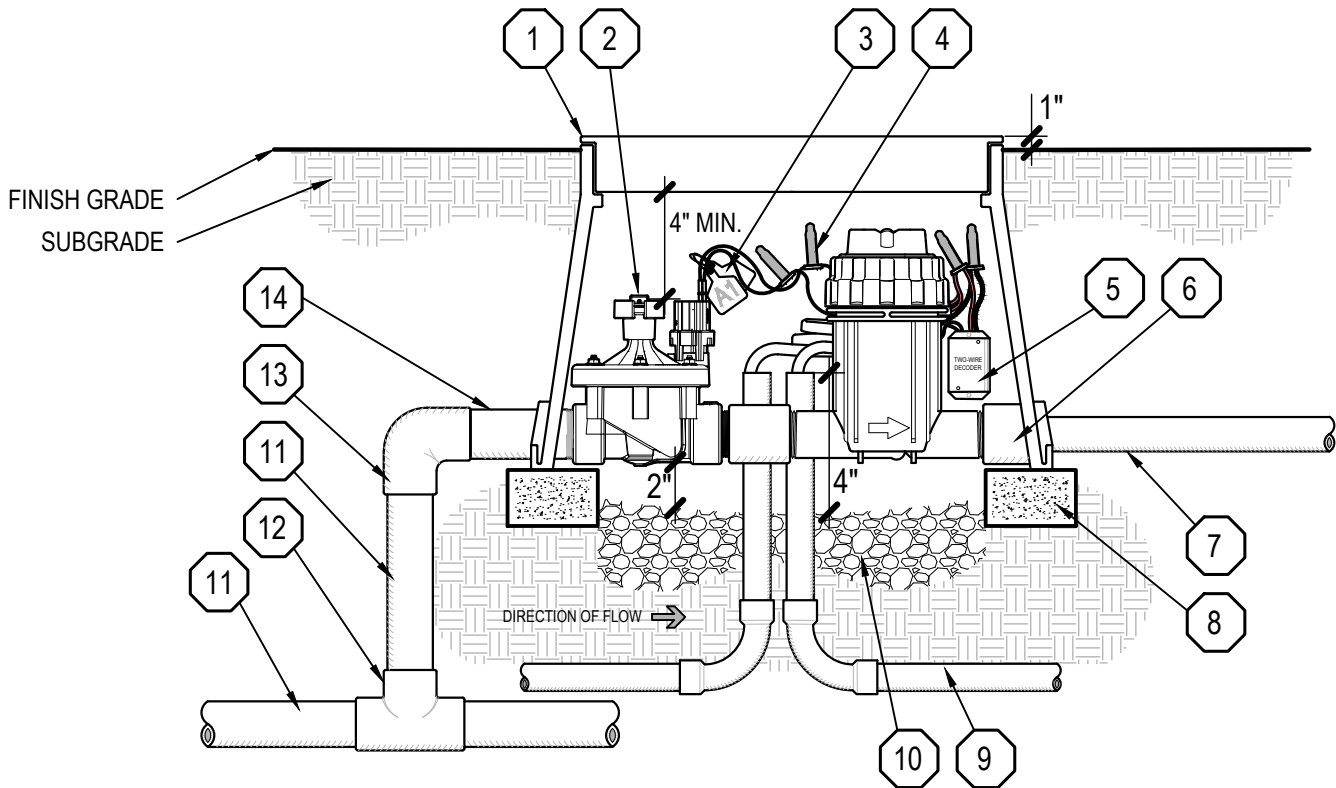

- | | |
|---|---|
| <ul style="list-style-type: none"> 1 LOCKING RECTANGULAR VALVE BOX (SEE DETAIL IRR-42) 2 REMOTE CONTROL VALVE DRIP KIT WITH DRIP FILTER AND PRESSURE REGULATOR 3 STATION ID TAG AND WATER IDENTIFICATION TAG - LOCATE ON SOLENOID WIRES - (SEE DETAIL IRR-38) TWO-WIRE - TWO-WIRE CABLE WITH 36" MINIMUM EXPANSION LOOP 4 CONVENTIONAL WIRE - VALVE WIRE AND COMMON WIRE WITH 36" MINIMUM EXPANSION COIL INCLUDE WATERPROOF WIRE CONNECTORS FOR ALL WIRE CONNECTIONS 5 TWO-WIRE DECODER - AS REQUIRED FOR TWO-WIRE SYSTEMS 6 SLIP X THREAD COUPLING - LATERAL FITTING WITH BUSHING TO ADAPT PIPE TO LATERAL SIZE | <ul style="list-style-type: none"> 7 LATERAL PIPE 8 BRICK SUPPORTS - FOUR REQUIRED 9 1-1/4" TWO-WIRE CABLE CONDUIT WITH SWEEPS IN AND OUT OF EACH VALVE BOX - FOR TWO-WIRE SYSTEMS 10 3/4" CRUSHED GRAVEL - 6" DEPTH 11 PRESSURE MAINLINE PIPE 12 SCHEDULE 80 PVC PRESSURE MAINLINE FITTING - SLIP TEE OR ELL 13 SCHEDULE 80 PVC SLIP ELL WITH BUSHING TO ADAPT PIPE TO INLET SIZE OF VALVE 14 SCHEDULE 80 PVC TOE NIPPLE - LENGTH TO CLEAR VALVE BOX |
|---|---|

MOULTON NIGUEL WATER DISTRICT

REMOTE CONTROL VALVE – DRIP

IRR-10

NOTES:

1. ALL THREADED CONNECTIONS TO USE NON-HARDENING THREAD SEALANT

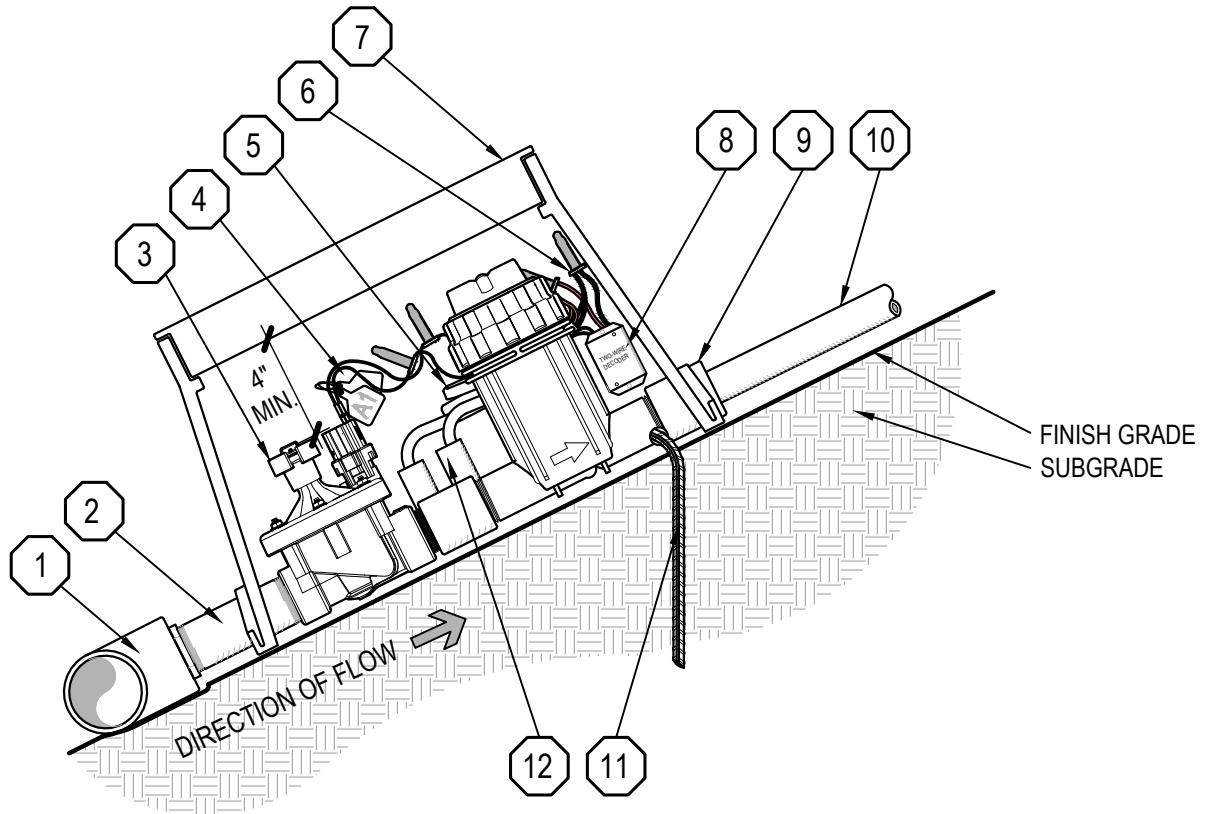

- | | |
|---|---|
| <p>1 GALVANIZED MAINLINE TEE OR ELL FITTING WITH THREADED REDUCER BUSHING</p> <p>2 SCHEDULE 40 GALVANIZED STEEL NIPPLE - INLET SIZE, LENGTH TO CLEAR VALVE BOX</p> <p>3 REMOTE CONTROL VALVE DRIP KIT WITH DRIP FILTER AND PRESSURE REGULATOR</p> <p>4 STATION ID TAG AND WATER IDENTIFICATION TAG - LOCATE ON SOLENOID WIRES - (SEE DETAIL IRR-38)</p> <p>5 TWO-WIRE - TWO-WIRE CABLE WITH 36" MINIMUM EXPANSION LOOP
CONVENTIONAL WIRE - VALVE WIRE AND COMMON WIRE WITH 36" MINIMUM EXPANSION COIL</p> | <p>6 INCLUDE WATERPROOF WIRE CONNECTORS FOR ALL WIRE CONNECTIONS</p> <p>7 LOCKING RECTANGULAR VALVE BOX (SEE DETAIL IRR-42)</p> <p>8 TWO-WIRE DECODER - AS REQUIRED FOR TWO-WIRE SYSTEMS</p> <p>9 SCHEDULE 40 UVR SLIP X THREAD COUPLING - LATERAL FITTING WITH BUSHING TO ADAPT PIPE TO LATERAL SIZE</p> <p>10 SCHEDULE 40 UVR LATERAL PIPE</p> <p>11 #4 REBAR - MINIMUM 18" LENGTH - INSTALL LONG END ON INSIDE OF BOX THROUGH 1" HOLE IN THE SIDE OF BOX</p> <p>12 1-1/4" TWO-WIRE CABLE CONDUIT WITH SWEEPS IN AND OUT OF EACH VALVE BOX - FOR TWO WIRE SYSTEMS</p> |
|---|---|

MOULTON NIGUEL WATER DISTRICT
REMOTE CONTROL VALVE – DRIP ON GRADE

IRR-11

NOTES:

1. ALL THREADED CONNECTIONS TO USE NON-HARDENING THREAD SEALANT
2. VALVE HANDLE TO HAVE 2" OF CLEARANCE FROM VALVE BOX IN BOTH OPEN AND CLOSED POSITION

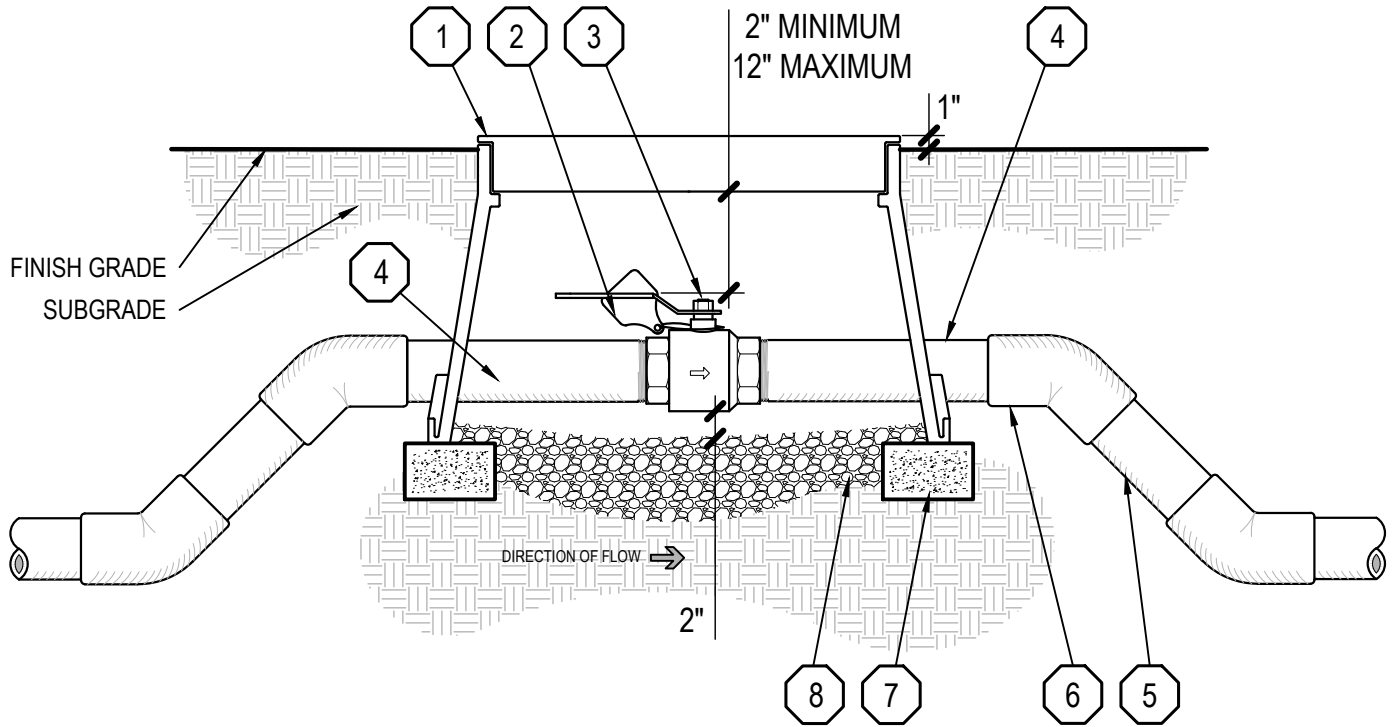

- | | |
|---|--|
| <ul style="list-style-type: none"> ① LOCKING RECTANGULAR VALVE BOX
(SEE DETAIL IRR-42) ② WATER IDENTIFICATION TAG - (SEE DETAIL IRR-38) ③ BALL VALVE ④ SCHEDULE 80 PVC TOE NIPPLE - LENGTH TO CLEAR
VALVE BOX | <ul style="list-style-type: none"> ⑤ PRESSURE MAINLINE PIPE ⑥ SCHEDULE 80 PVC PRESSURE MAINLINE FITTING - SLIP
45° ELL ⑦ BRICK SUPPORTS - FOUR REQUIRED ⑧ 3/4" CRUSHED GRAVEL - 6" DEPTH |
|---|--|

MOULTON NIGUEL WATER DISTRICT

ISOLATION VALVE

IRR-12

NOTES:

1. ALL THREADED CONNECTIONS TO USE NON-HARDENING THREAD SEALANT
2. VALVE HANDLE TO HAVE 2" OF CLEARANCE FROM VALVE BOX IN BOTH OPEN AND CLOSED POSITION

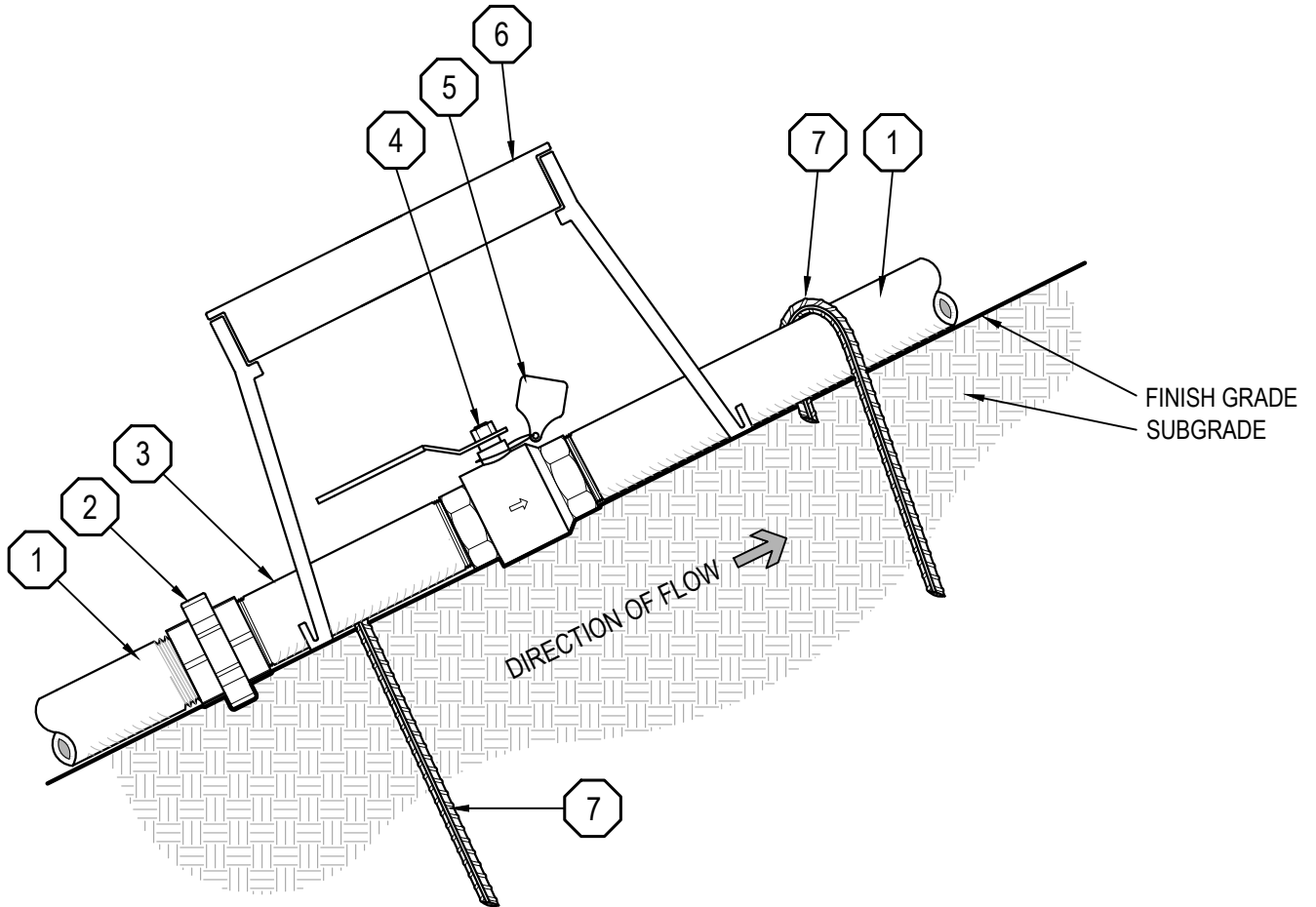

- | | |
|---|--|
| <ul style="list-style-type: none"> 1 GALVANIZED MAINLINE 2 GALVANIZED UNION 3 GALVANIZED NIPPLE, 24" MINIMUM LENGTH 4 ISOLATION VALVE | <ul style="list-style-type: none"> 5 WATER IDENTIFICATION TAG - (SEE DETAIL IRR-38) 6 LOCKING RECTANGULAR OR JUMBO VALVE BOX (SEE DETAIL IRR-42) 7 #4 REBAR ANCHORS PER DETAIL MINIMUM 18" LENGTH |
|---|--|

MOULTON NIGUEL WATER DISTRICT

ISOLATION VALVE ON GRADE

IRR-13

NOTES:

1. ALL BURIED BRASS PIPE SHALL BE WRAPPED USING PIPE WRAP TAPE: 10-MIL BUTYL RUBBER WITH POLYETHYLENE BACKING OVER PRIMER.
2. ALL THREADED CONNECTIONS TO USE NON-HARDENING THREAD SEALANT

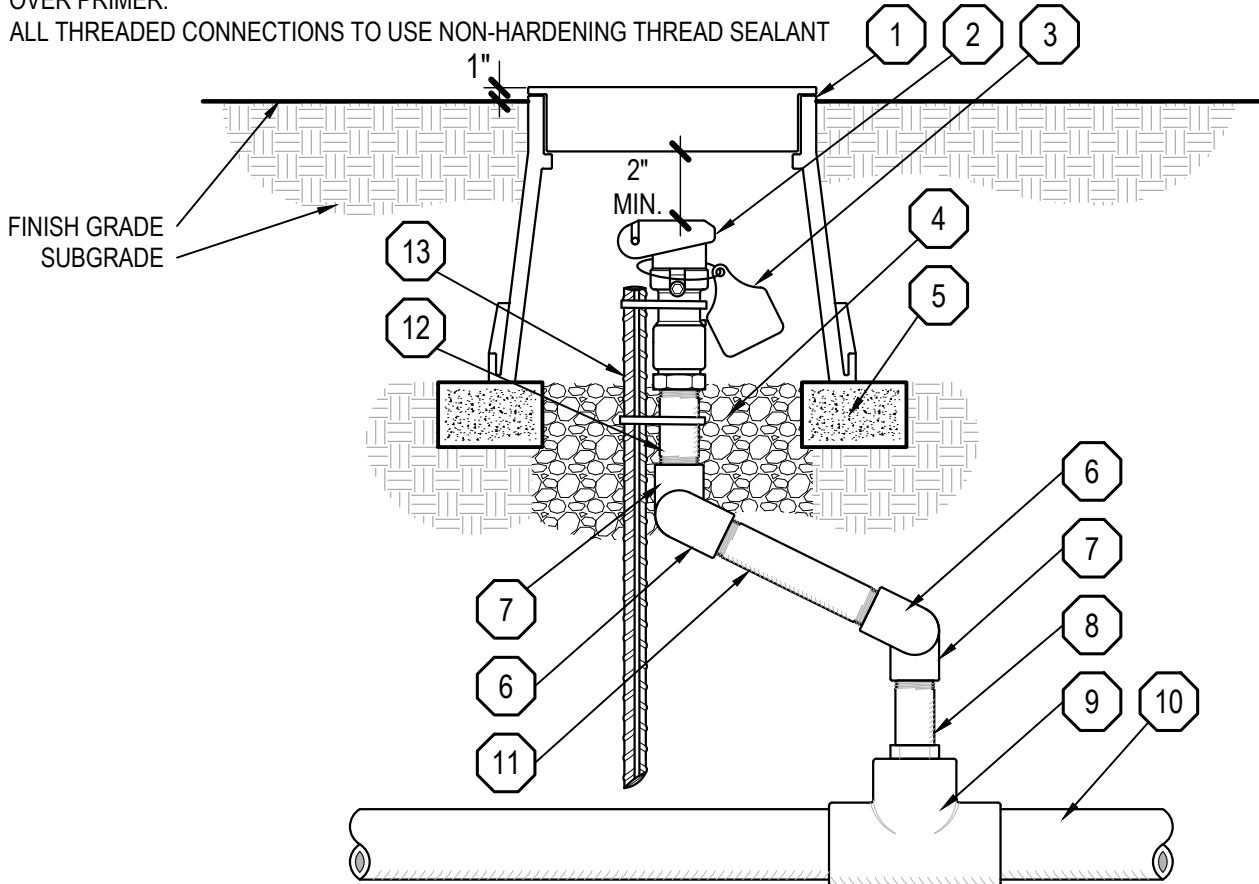

- | | |
|--|--|
| <ul style="list-style-type: none"> 1 10" LOCKING ROUND VALVE BOX - (SEE DETAIL IRR-42) 2 ACME THREADED QUICK COUPLER VALVE WITH LOCKING PURPLE COVER 3 WATER IDENTIFICATION TAG - (SEE DETAIL IRR-38) 4 3/4" CRUSHED GRAVEL - 6" DEPTH 5 BRICK SUPPORTS - TWO REQUIRED 6 SCHEDULE 40 BRASS STREET ELBOW - INLET SIZE 7 SCHEDULE 40 BRASS ELBOW - INLET SIZE | <ul style="list-style-type: none"> 8 PVC SCHEDULE 80 PVC TOE NIPPLE - LENGTH AS REQUIRED 9 SCHEDULE 80 PVC TEE OR ELL FITTING WITH BUSHING TO ADAPT PIPE TO INLET SIZE OF QUICK COUPLER 10 PRESSURE MAINLINE PIPE 11 SCHEDULE 40 BRASS NIPPLE - INLET SIZE x 12" LENGTH 12 SCHEDULE 40 BRASS NIPPLE - INLET SIZE x 2" LENGTH 13 #4 REBAR - MINIMUM 18" LENGTH - SECURE TO QUICK COUPLER WITH (2) STAINLESS STEEL HOSE CLAMPS |
|--|--|

MOULTON NIGUEL WATER DISTRICT

QUICK COUPLER

IRR-14

NOTES:

1. ALL THREADED CONNECTIONS TO USE NON-HARDENING THREAD SEALANT

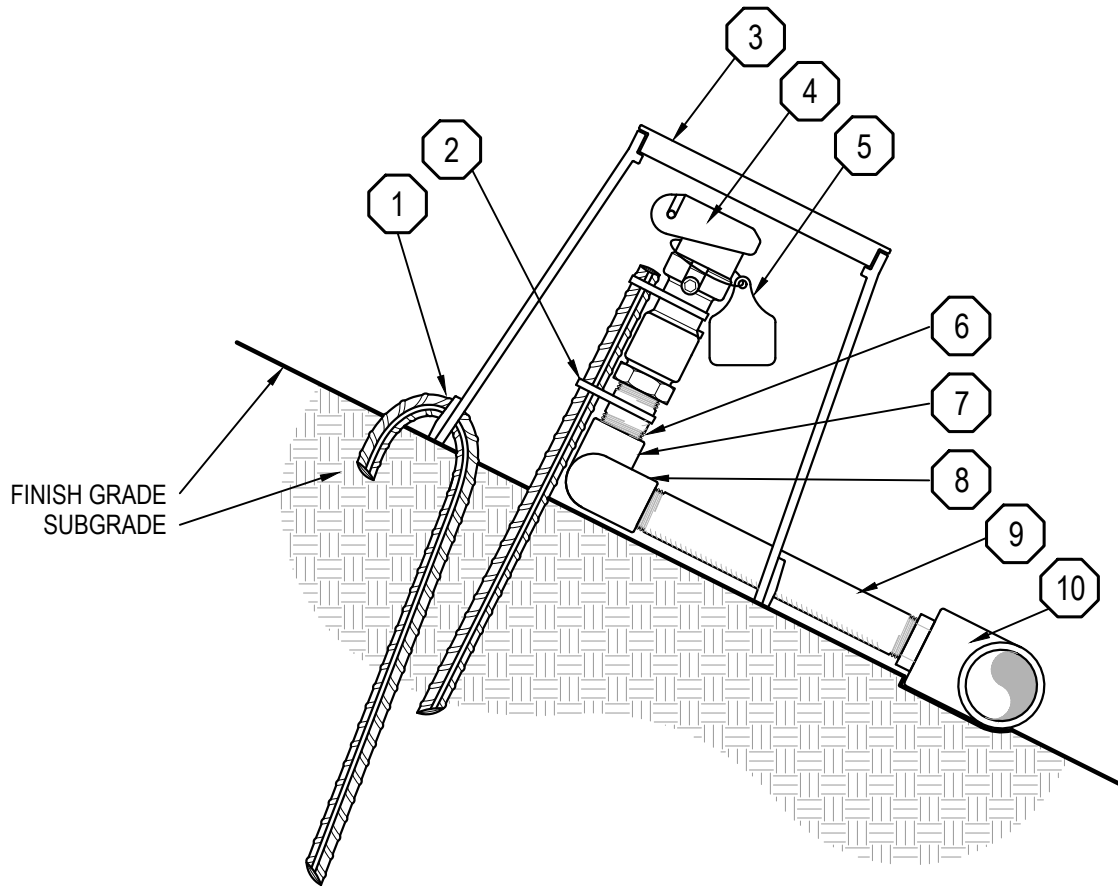

- | | |
|--|--|
| <p>1 #4 REBAR - MINIMUM 18" LENGTH - INSTALL LONG END ON INSIDE OF BOX THROUGH 1" HOLE IN THE SIDE OF BOX</p> <p>2 #4 REBAR - MINIMUM 18" LENGTH - SECURE TO QUICK COUPLER WITH (2) STAINLESS STEEL HOSE CLAMPS</p> <p>3 10" LOCKING ROUND VALVE BOX - (SEE DETAIL IRR-42)</p> <p>4 ACME THREADED QUICK COUPLING VALVE WITH LOCKING PURPLE COVER</p> <p>5 WATER IDENTIFICATION TAG - (SEE DETAIL IRR-38)</p> | <p>6 SCHEDULE 40 BRASS NIPPLE - INLET SIZE</p> <p>7 SCHEDULE 40 BRASS THREADED ELL - INLET SIZE</p> <p>8 SCHEDULE 40 BRASS STREET ELL - INLET SIZE</p> <p>9 SCHEDULE 40 GALVANIZED STEEL NIPPLE - INLET SIZE, LENGTH TO CLEAR VALVE BOX</p> <p>10 GALVANIZED MAINLINE TEE OR ELL FITTING WITH THREADED REDUCER BUSHING</p> |
|--|--|

MOULTON NIGUEL WATER DISTRICT

QUICK COUPLER ON GRADE

IRR-15

NOTES:

1. ALL THREADED CONNECTIONS TO USE NON-HARDENING THREAD SEALANT

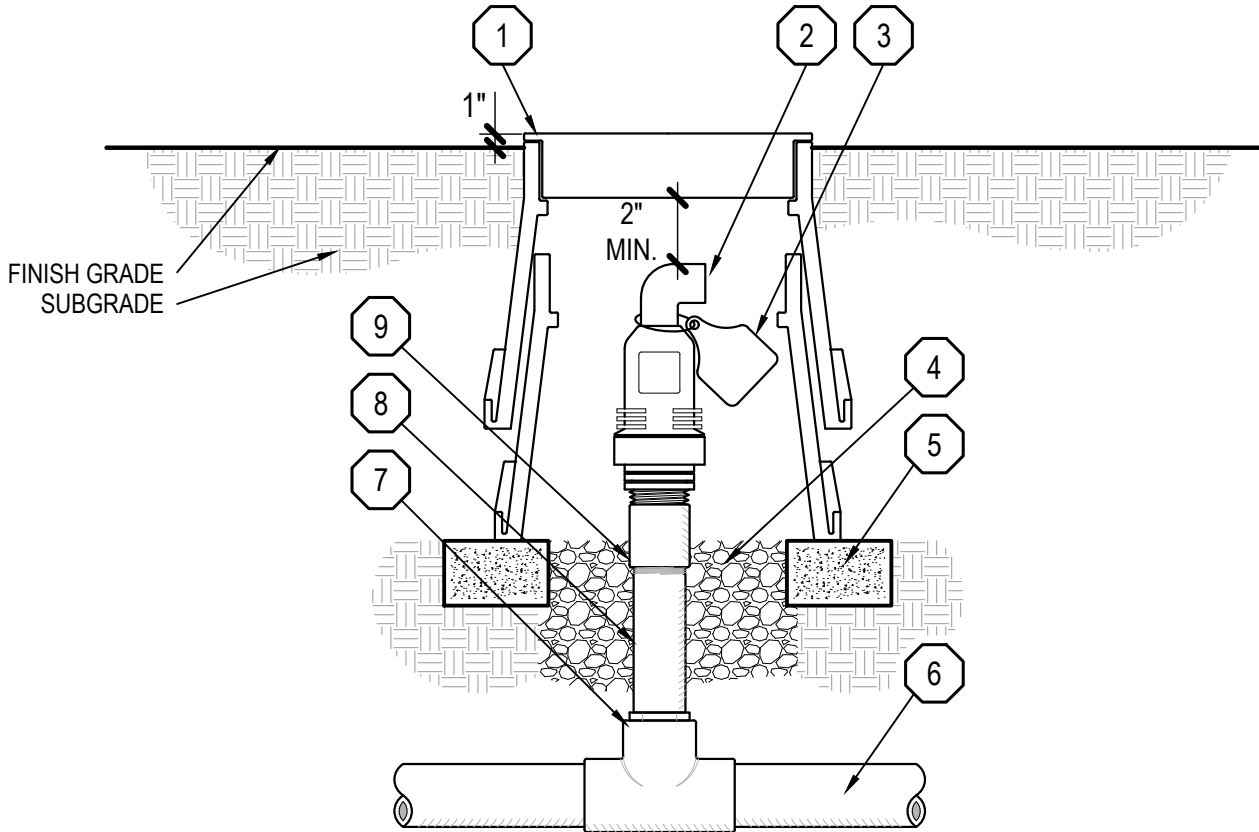

- | | |
|---|---|
| <ul style="list-style-type: none"> ① 10" LOCKING ROUND VALVE BOX WITH VALVE BOX EXTENSIONS AS REQUIRED - (SEE DETAIL IRR-42) ② AIR / VACUUM RELIEF VALVE ③ WATER IDENTIFICATION TAG - (SEE DETAIL IRR-38) ④ 3/4" CRUSHED GRAVEL - 6" DEPTH ⑤ BRICK SUPPORTS - TWO REQUIRED | <ul style="list-style-type: none"> ⑥ PRESSURE MAINLINE PIPE ⑦ SCHEDULE 80 PVC SLIP TEE OR ELL WITH BUSHING TO ADAPT PIPE TO INLET SIZE OF AIR RELIEF ⑧ PVC SCHEDULE 80 PVC TOE NIPPLE - LENGTH AS REQUIRED ⑨ SCHEDULE 80 PVC T-x-T COUPLING |
|---|---|

MOULTON NIGUEL WATER DISTRICT

AIR RELIEF

IRR-16

NOTES:

1. ALL THREADED CONNECTIONS TO USE NON-HARDENING THREAD SEALANT

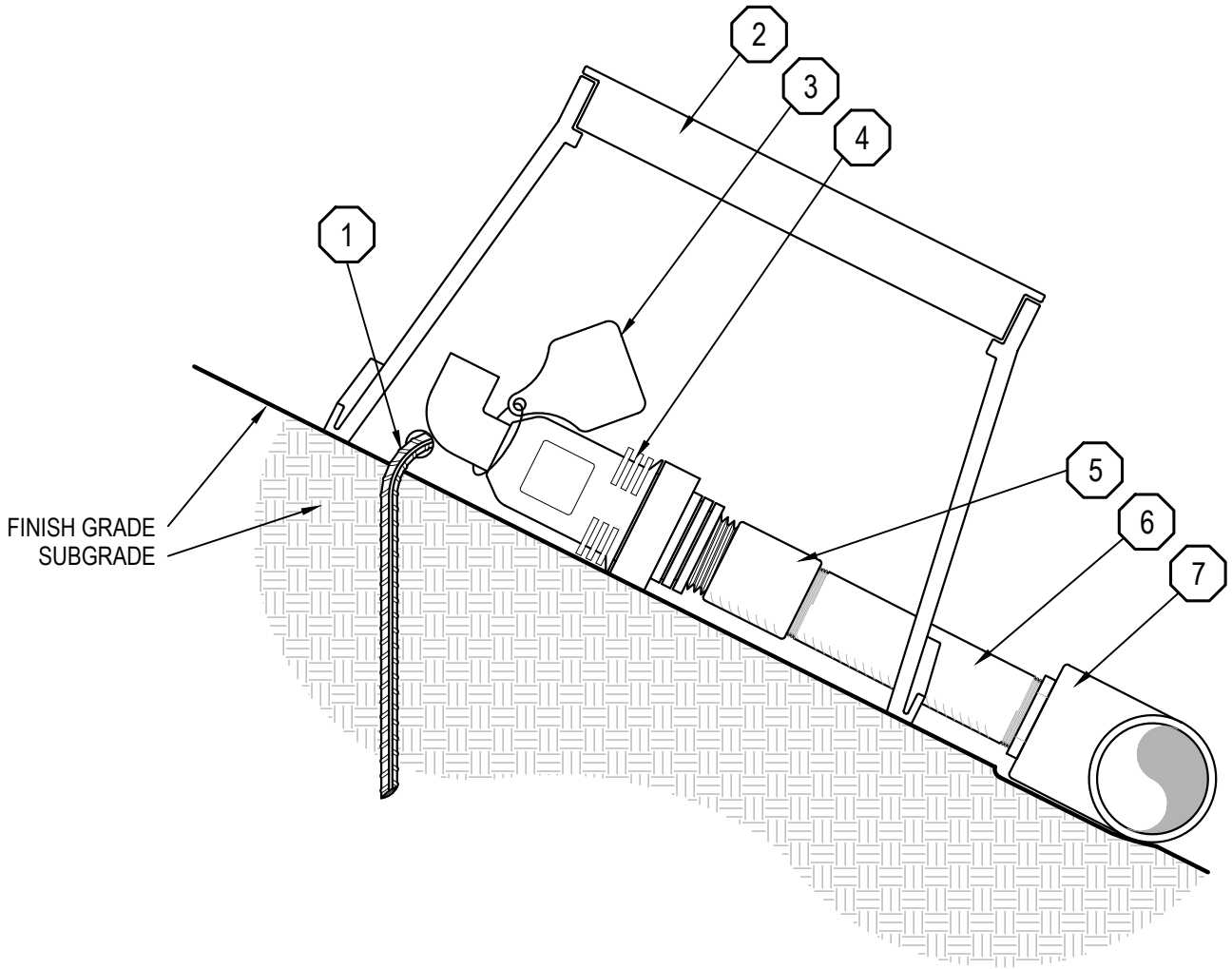

- 1 #4 REBAR - MINIMUM 18" LENGTH - INSTALL LONG END ON INSIDE OF BOX THROUGH 1" HOLE IN THE SIDE OF BOX
- 2 LOCKING RECTANGULAR VALVE BOX (SEE DETAIL IRR-42)
- 3 WATER IDENTIFICATION TAG - (SEE DETAIL IRR-38)
- 4 AIR RELIEF VALVE

- 5 SCHEDULE 40 GALVANIZED STEEL T x T COUPLING
- 6 SCHEDULE 40 GALVANIZED STEEL NIPPLE - INLET SIZE, LENGTH TO CLEAR VALVE BOX
- 7 GALVANIZED MAINLINE TEE OR ELL FITTING WITH THREADED REDUCER BUSHING

MOULTON NIGUEL WATER DISTRICT

AIR RELIEF ON GRADE

IRR-17

NOTES:

1. ONLY HIGH EFFICIENCY ADJUSTABLE ARC MATCH PRECIPITATION RATE (MPR) NOZZLES TO BE UTILIZED
2. ADJUST RADIUS AND ARC PATTERN TO ELIMINATE OVERSPRAY WHILE MAINTAINING HEAD TO HEAD COVERAGE
3. RECYCLED WATER IDENTIFICATION REQUIRED ON ALL SPRINKLER HEADS USING RECYCLED WATER. USE OF IRRIGATION MANUFACTURER'S SUPPLIED IDENTIFICATION PRODUCTS IS MANDATORY

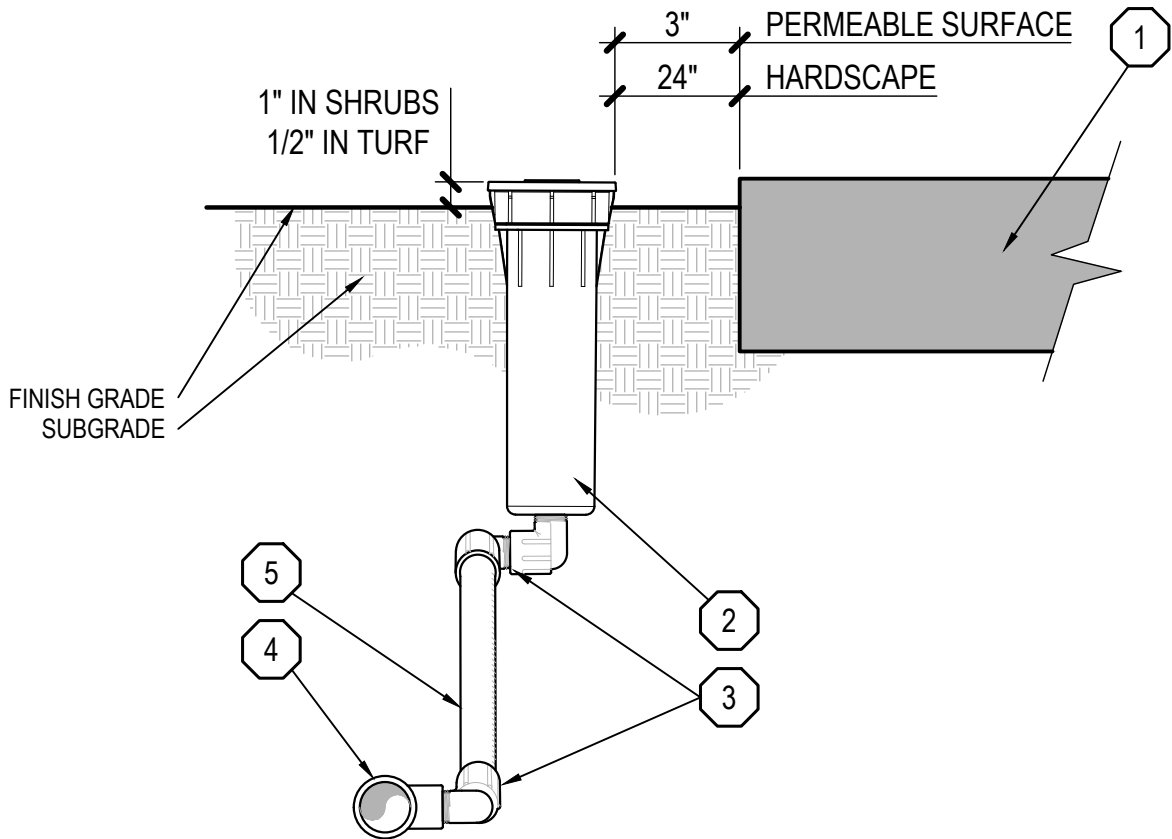

- | | |
|---|--|
| <p>① PERMEABLE SURFACE, HARDSCAPE OR STRUCTURE</p> <p>② POP-UP SPRAY HEAD</p> <p>③ MARLEX 90 DEGREE STREET ELBOW - INLET SIZE</p> | <p>④ PVC SCHEDULE 40 SxSxT TEE OR 90 DEGREE ELBOW CONNECTED TO LATERAL PIPE</p> <p>⑤ PVC SCHEDULE 80 NIPPLE - 6" MIN, LENGTH AS REQUIRED</p> |
|---|--|

MOULTON NIGUEL WATER DISTRICT	IRR-18
POP-UP SPRAY HEAD	

NOTES:

1. ONLY HIGH EFFICIENCY ADJUSTABLE ARC MATCH PRECIPITATION RATE (MPR) NOZZLES TO BE UTILIZED
2. ADJUST RADIUS AND ARC PATTERN TO ELIMINATE OVERSPRAY WHILE MAINTAINING HEAD TO HEAD COVERAGE
3. RECYCLED WATER IDENTIFICATION REQUIRED ON ALL SPRINKLER HEADS USING RECYCLED WATER. USE OF IRRIGATION MANUFACTURER'S SUPPLIED IDENTIFICATION PRODUCTS IS MANDATORY

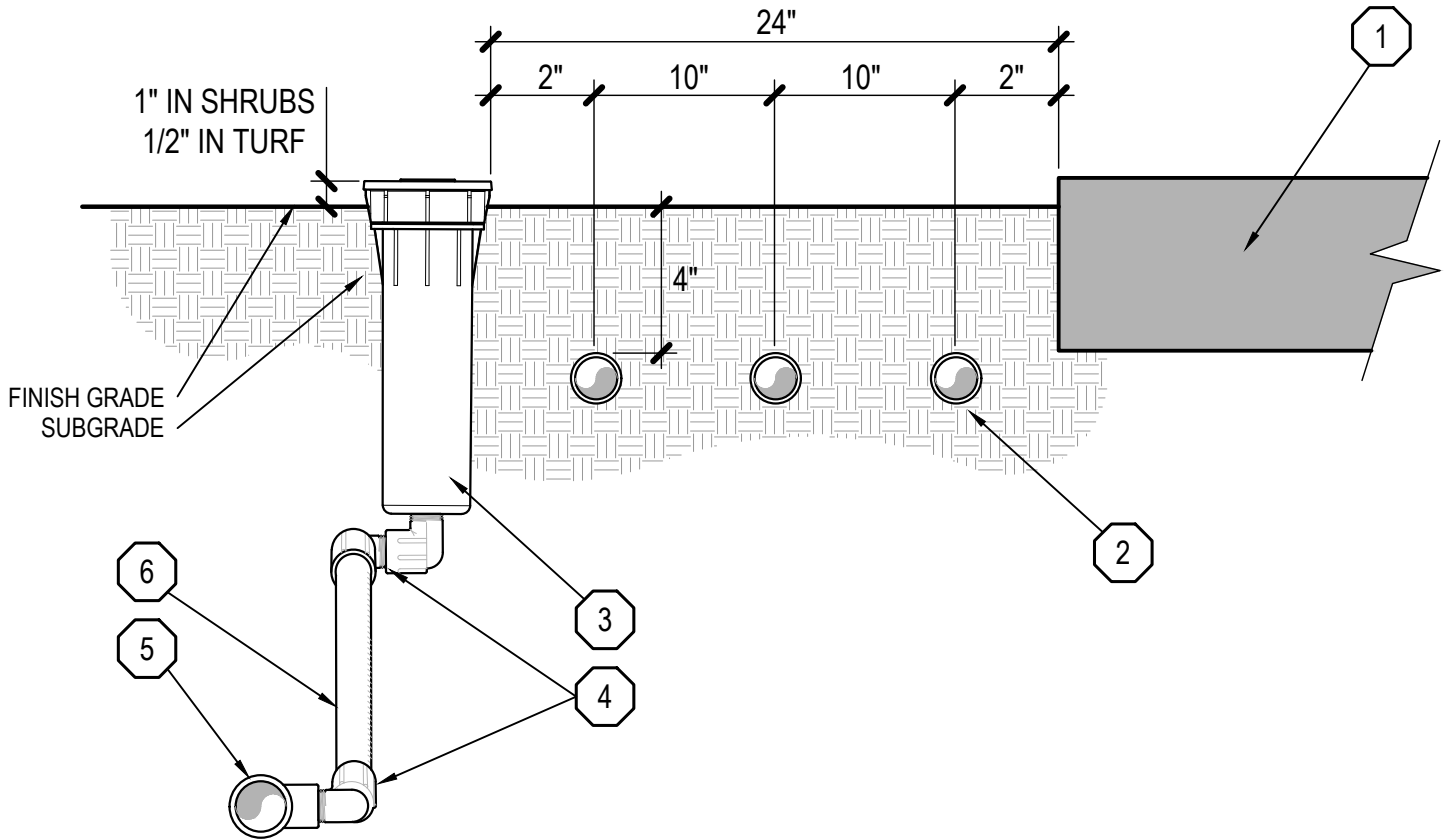

- | | |
|---|--|
| <p>① HARDSCAPE OR STRUCTURE</p> <p>② SOLID PURPLE INLINE DRIP TUBING</p> <p>③ POP-UP SPRAY HEAD</p> | <p>④ MARLEX 90 DEGREE STREET ELBOW - INLET SIZE</p> <p>⑤ PVC SCHEDULE 40 SxSxT TEE OR 90 DEGREE ELBOW CONNECTED TO LATERAL PIPE</p> <p>⑥ PVC SCHEDULE 80 NIPPLE - 6" MIN, LENGTH AS REQUIRED</p> |
|---|--|

MOULTON NIGUEL WATER DISTRICT
POP-UP SPRAY HEAD WITH DRIP

IRR-19

NOTES:

1. ONLY HIGH EFFICIENCY ADJUSTABLE ARC MATCH PRECIPITATION RATE (MPR) NOZZLES TO BE UTILIZED
2. ADJUST RADIUS AND ARC PATTERN TO ELIMINATE OVERSPRAY WHILE MAINTAINING HEAD TO HEAD COVERAGE
3. RECYCLED WATER IDENTIFICATION REQUIRED ON ALL SPRINKLER HEADS USING RECYCLED WATER. USE OF IRRIGATION MANUFACTURER'S SUPPLIED IDENTIFICATION PRODUCTS IS MANDATORY

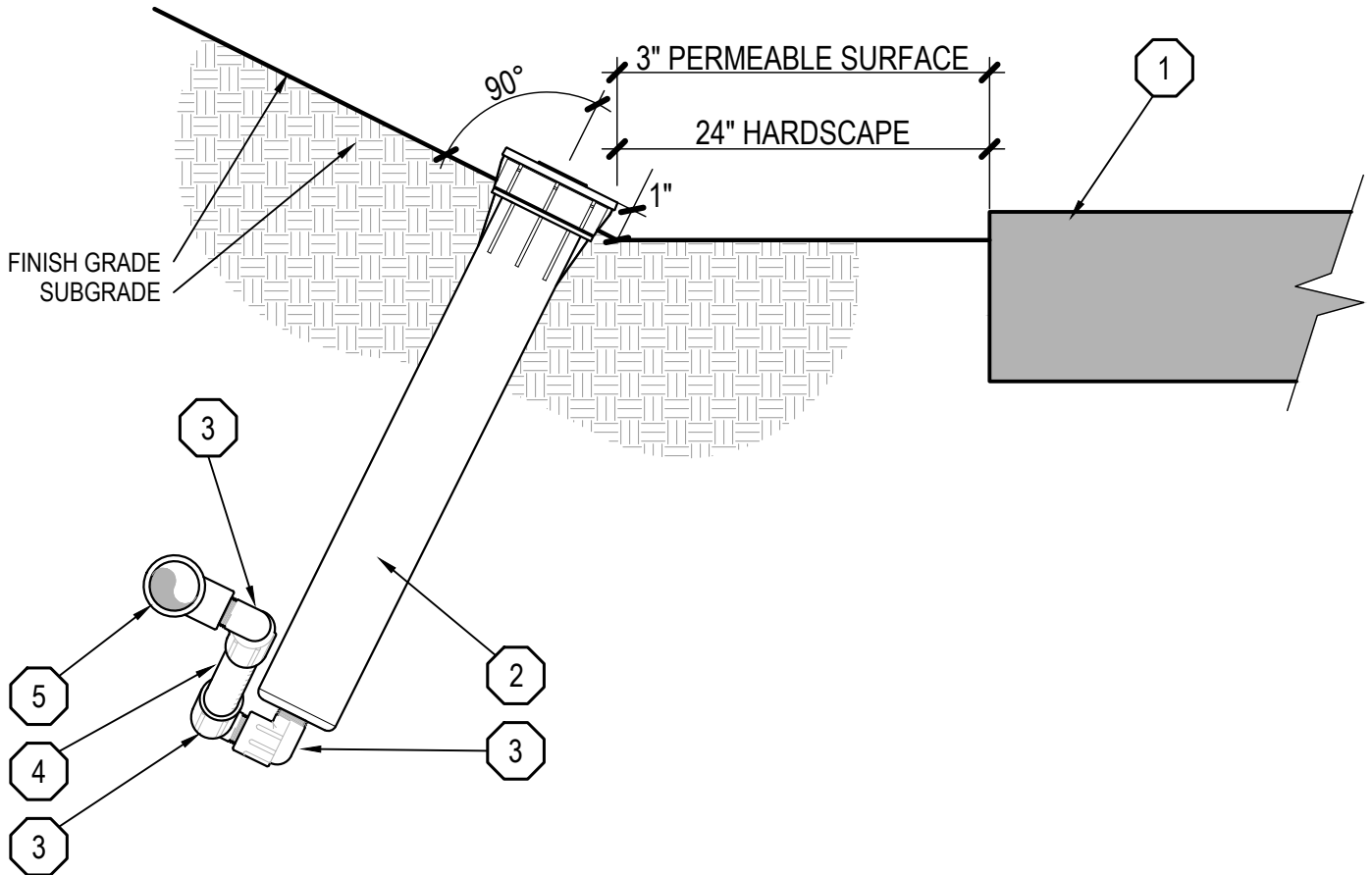

- | | |
|---|--|
| <p>① PERMEABLE SURFACE, HARDSCAPE OR STRUCTURE</p> <p>② POP-UP SPRAY HEAD</p> <p>③ MARLEX 90 DEGREE STREET ELBOW - INLET SIZE</p> | <p>④ PVC SCHEDULE 80 NIPPLE - 6" MIN, LENGTH AS REQUIRED</p> <p>⑤ PVC SCHEDULE 40 SxSxT TEE OR 90 DEGREE ELBOW CONNECTED TO LATERAL PIPE</p> |
|---|--|

MOULTON NIGUEL WATER DISTRICT

POP-UP SPRAY HEAD TOE OF SLOPE

IRR-20

NOTES:

1. ONLY HIGH EFFICIENCY ADJUSTABLE ARC MATCH PRECIPITATION RATE (MPR) NOZZLES TO BE UTILIZED
2. ADJUST RADIUS AND ARC PATTERN TO ELIMINATE OVERSPRAY WHILE MAINTAINING HEAD TO HEAD COVERAGE
3. RECYCLED WATER IDENTIFICATION REQUIRED ON ALL SPRINKLER HEADS USING RECYCLED WATER. USE OF IRRIGATION MANUFACTURER'S SUPPLIED IDENTIFICATION PRODUCTS IS MANDATORY

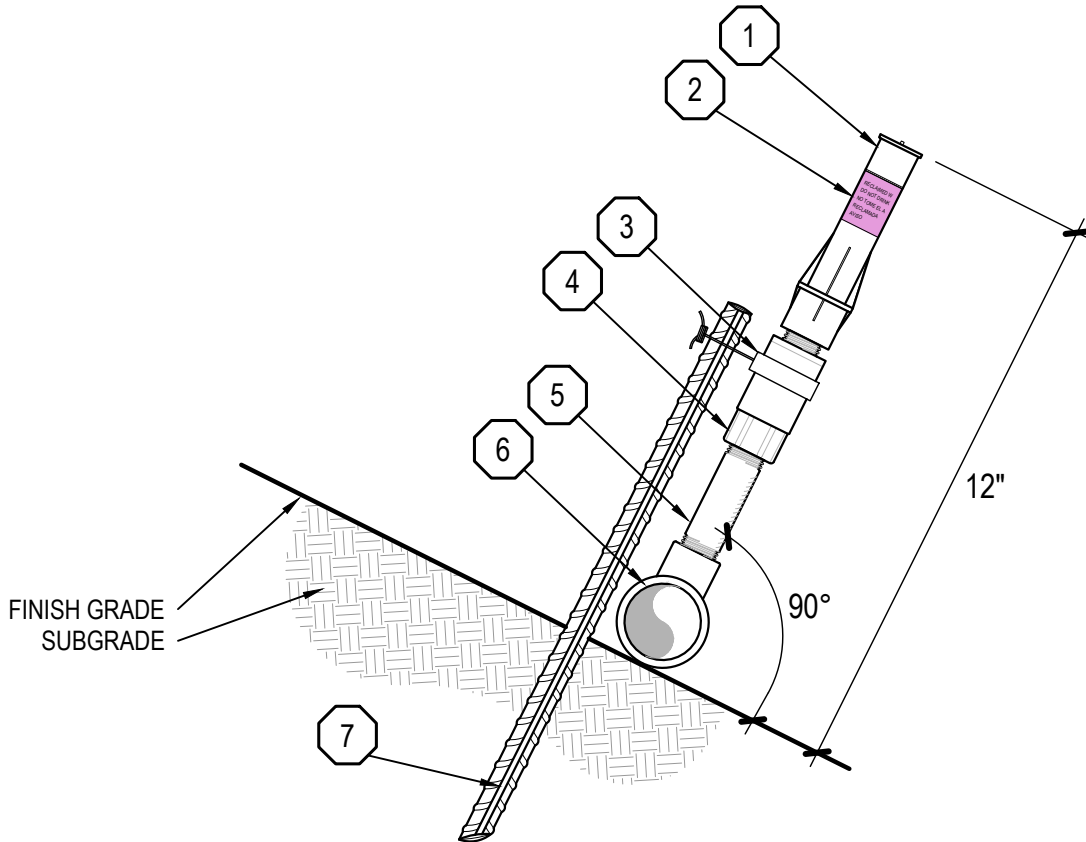

- | | | | |
|---|---|---|--|
| 1 | SPRAY NOZZLE WITH RISER ADAPTER | 5 | PVC SCHEDULE 80 NIPPLE - LENGTH AS REQUIRED |
| 2 | PURPLE RECYCLED WATER IDENTIFICATION STICKER | 6 | PVC SCHEDULE 40 SxSxT TEE OR 90 DEGREE ELBOW |
| 3 | (1) SPRINKLER TWIST TIE - INSTALL WITH TWIST TIE TOOL | 7 | 24" LONG #4 REBAR STABILIZER - BURY 18" DEEP |
| 4 | PVC SCHEDULE 40 FPT x MPT CHECK VALVE - ADJUST BEFORE INSTALLATION TO PREVENT LOW HEAD DRAINAGE | | |

MOULTON NIGUEL WATER DISTRICT

SHRUB SPRAY ON RISER

IRR-21

NOTES:

1. MATCH PRECIPITATION RATE (MPR) NOZZLES TO BE UTILIZED WHERE POSSIBLE. IF NOT POSSIBLE: QUARTER, HALF AND FULL HEADS TO BE INSTALL ON SEPARATE VALVES
2. ADJUST RADIUS AND ARC PATTERN TO ELIMINATE OVERSPRAY WHILE MAINTAINING HEAD TO HEAD COVERAGE
3. RECYCLED WATER IDENTIFICATION REQUIRED ON ALL SPRINKLER HEADS USING RECYCLED WATER. USE OF IRRIGATION MANUFACTURER'S SUPPLIED IDENTIFICATION PRODUCTS IS MANDATORY

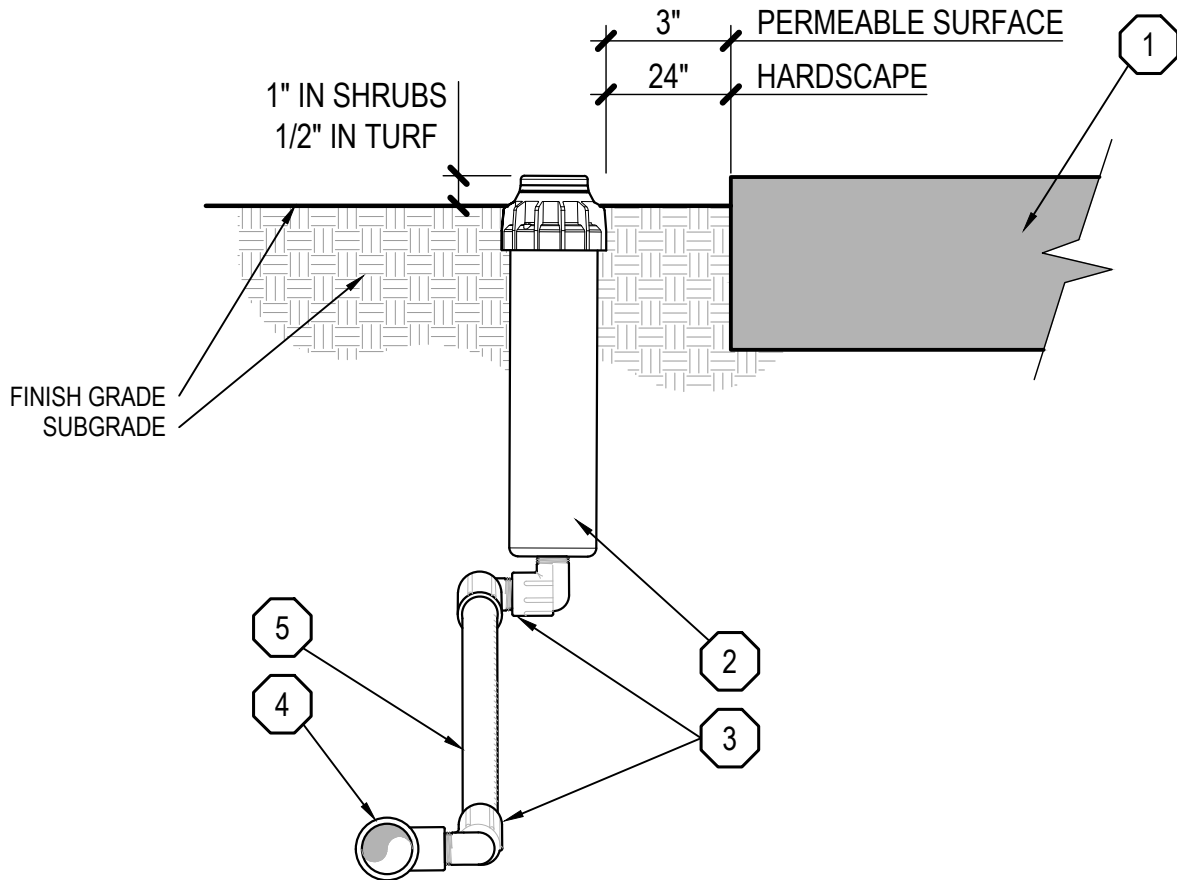

- | | |
|---|--|
| <p>① PERMEABLE SURFACE, HARDSCAPE OR STRUCTURE</p> <p>② POP-UP ROTOR</p> <p>③ PVC SCHEDULE 40 STREET ELL - INLET SIZE</p> | <p>④ PVC SCHEDULE 40 SxSxT TEE OR 90 DEGREE ELBOW CONNECTED TO LATERAL PIPE</p> <p>⑤ PVC SCHEDULE 80 NIPPLE - 6" MIN, LENGTH AS REQUIRED</p> |
|---|--|

MOULTON NIGUEL WATER DISTRICT	IRR-22
POP-UP ROTOR	

NOTES:

1. MATCH PRECIPITATION RATE (MPR) NOZZLES TO BE UTILIZED WHERE POSSIBLE. IF NOT POSSIBLE: QUARTER, HALF AND FULL HEADS TO BE INSTALL ON SEPARATE VALVES
2. ADJUST RADIUS AND ARC PATTERN TO ELIMINATE OVERSPRAY WHILE MAINTAINING HEAD TO HEAD COVERAGE
3. RECYCLED WATER IDENTIFICATION REQUIRED ON ALL SPRINKLER HEADS USING RECYCLED WATER. USE OF IRRIGATION MANUFACTURER'S SUPPLIED IDENTIFICATION PRODUCTS IS MANDATORY

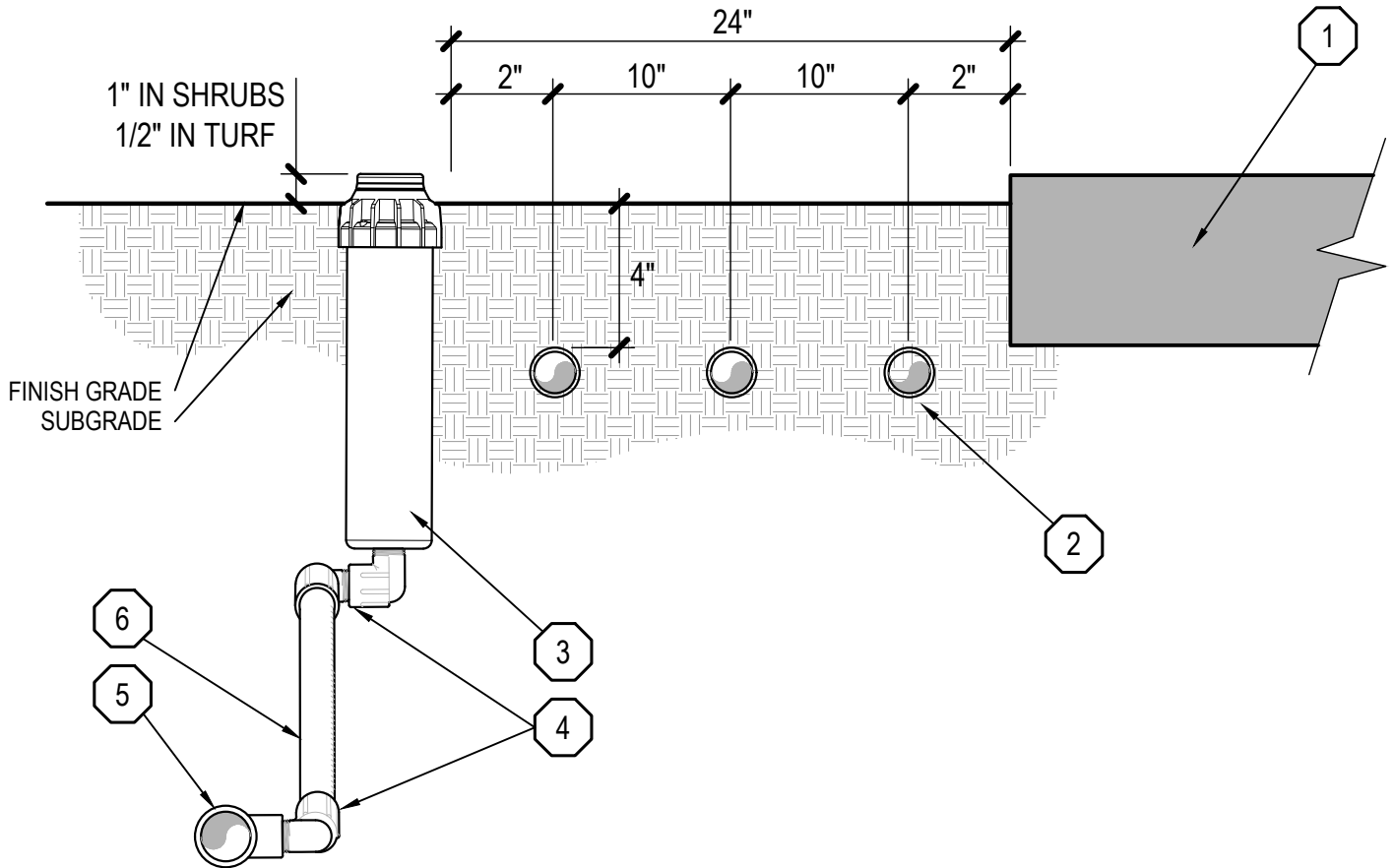

- | | |
|---|--|
| <p>① HARDSCAPE OR STRUCTURE</p> <p>② SOLID PURPLE INLINE DRIP TUBING</p> <p>③ POP-UP ROTOR HEAD</p> | <p>④ MARLEX 90 DEGREE STREET ELBOW - INLET SIZE</p> <p>⑤ PVC SCHEDULE 40 SxSxT TEE OR 90 DEGREE ELBOW CONNECTED TO LATERAL PIPE</p> <p>⑥ PVC SCHEDULE 80 NIPPLE - 6" MIN, LENGTH AS REQUIRED</p> |
|---|--|

MOULTON NIGUEL WATER DISTRICT

POP-UP ROTOR WITH DRIP

IRR-23

NOTES:

1. MATCH PRECIPITATION RATE (MPR) NOZZLES TO BE UTILIZED WHERE POSSIBLE. IF NOT POSSIBLE: QUARTER, HALF AND FULL HEADS TO BE INSTALL ON SEPARATE VALVES
2. ADJUST RADIUS AND ARC PATTERN TO ELIMINATE OVERSPRAY WHILE MAINTAINING HEAD TO HEAD COVERAGE
3. RECYCLED WATER IDENTIFICATION REQUIRED ON ALL SPRINKLER HEADS USING RECYCLED WATER. USE OF IRRIGATION MANUFACTURER'S SUPPLIED IDENTIFICATION PRODUCTS IS MANDATORY

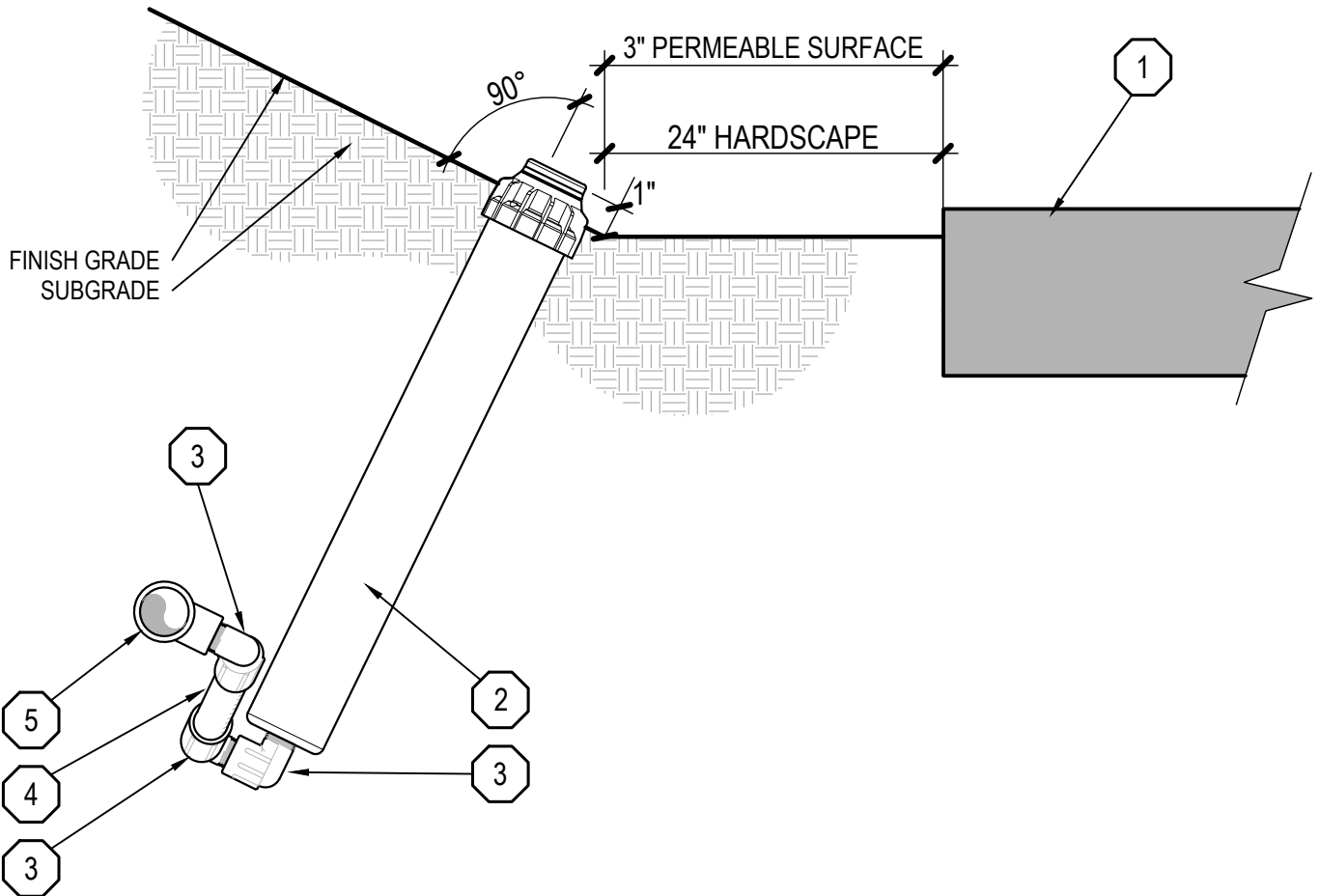

- | | |
|---|--|
| <p>① PERMEABLE SURFACE, HARDSCAPE OR STRUCTURE</p> <p>② POP-UP ROTOR</p> <p>③ PVC SCHEDULE 40 STREET ELL - INLET SIZE</p> | <p>④ PVC SCHEDULE 80 NIPPLE - 6" MIN, LENGTH AS REQUIRED</p> <p>⑤ PVC SCHEDULE 40 SxSxT TEE OR 90 DEGREE ELBOW CONNECTED TO LATERAL PIPE</p> |
|---|--|

MOULTON NIGUEL WATER DISTRICT

POP-UP ROTOR TOE OF SLOPE

IRR-24

NOTES:

1. MATCH PRECIPITATION RATE (MPR) NOZZLES TO BE UTILIZED WHERE POSSIBLE. IF NOT POSSIBLE: QUARTER, HALF AND FULL HEADS TO BE INSTALL ON SEPARATE VALVES
2. ADJUST RADIUS AND ARC PATTERN TO ELIMINATE OVERSPRAY WHILE MAINTAINING HEAD TO HEAD COVERAGE
3. RECYCLED WATER IDENTIFICATION REQUIRED ON ALL SPRINKLER HEADS USING RECYCLED WATER. USE OF IRRIGATION MANUFACTURER'S SUPPLIED IDENTIFICATION PRODUCTS IS MANDATORY

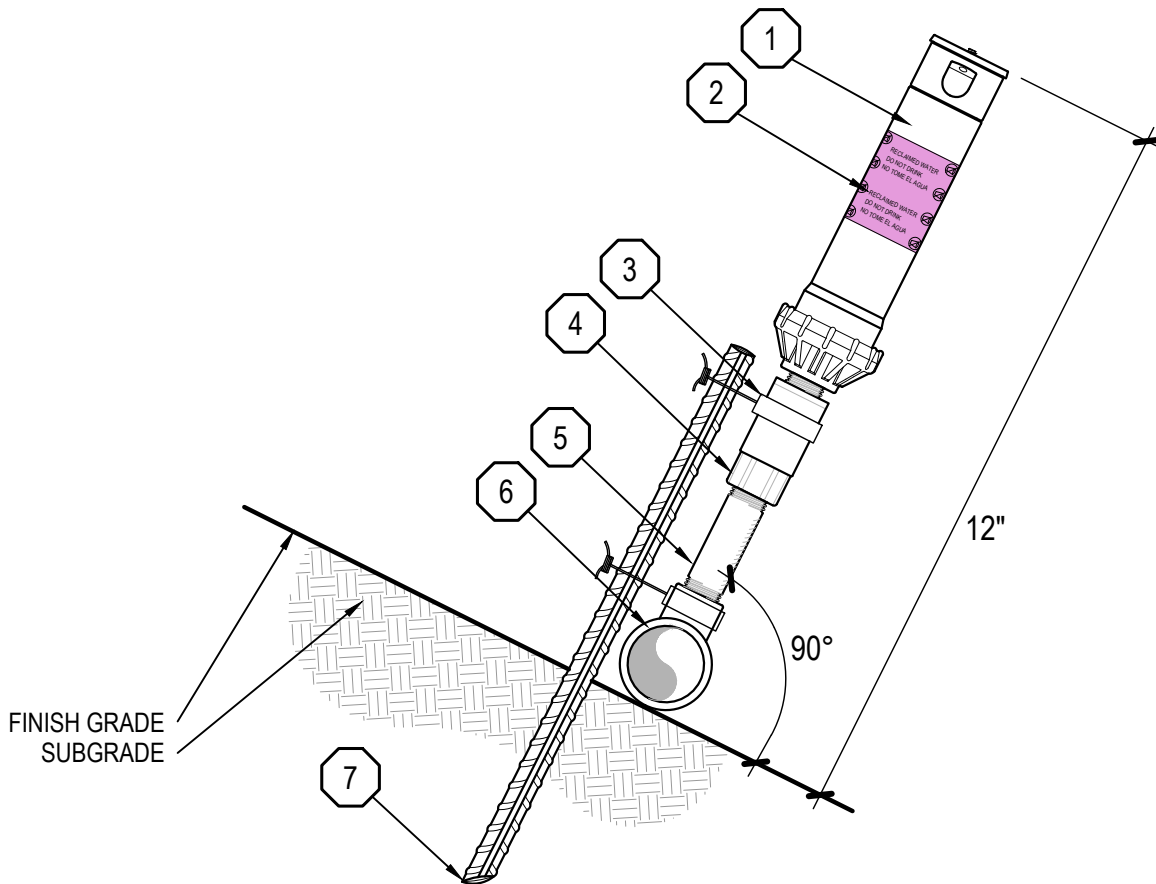

- | | |
|---|---|
| <p>1 SHRUB ROTOR HEAD</p> <p>2 PURPLE RECYCLED WATER IDENTIFICATION STICKER</p> <p>3 (2) SPRINKLER TWIST TIE - INSTALL WITH TWIST TIE TOOL</p> <p>4 PVC SCHEDULE 40 FPT x MPT CHECK VALVE - ADJUST BEFORE INSTALLATION TO PREVENT LOW HEAD DRAINAGE</p> | <p>5 3/4" PVC SCHEDULE 80 NIPPLE - LENGTH AS REQUIRED</p> <p>6 PVC SCHEDULE 40 SxSxT TEE OR 90 DEGREE ELBOW</p> <p>7 24" LONG #4 REBAR STABILIZER - BURY 18" DEEP</p> |
|---|---|

NOTES:

1. ADJUST RADIUS AND ARC PATTERN TO ELIMINATE OVERSPRAY ONTO HARDSCAPE AND DRAINAGE DITCHES WHILE MAINTAINING HEAD TO HEAD COVERAGE
2. SHRUB IRRIGATION HYDROZONES LESS THAN OR EQUAL TO 8' WIDE SHALL BE IRRIGATED WITH DRIP IRRIGATION
3. RECYCLED WATER IDENTIFICATION REQUIRED ON ALL SPRINKLER HEADS USING RECYCLED WATER. USE OF IRRIGATION MANUFACTURER'S SUPPLIED IDENTIFICATION PRODUCTS IS MANDATORY.

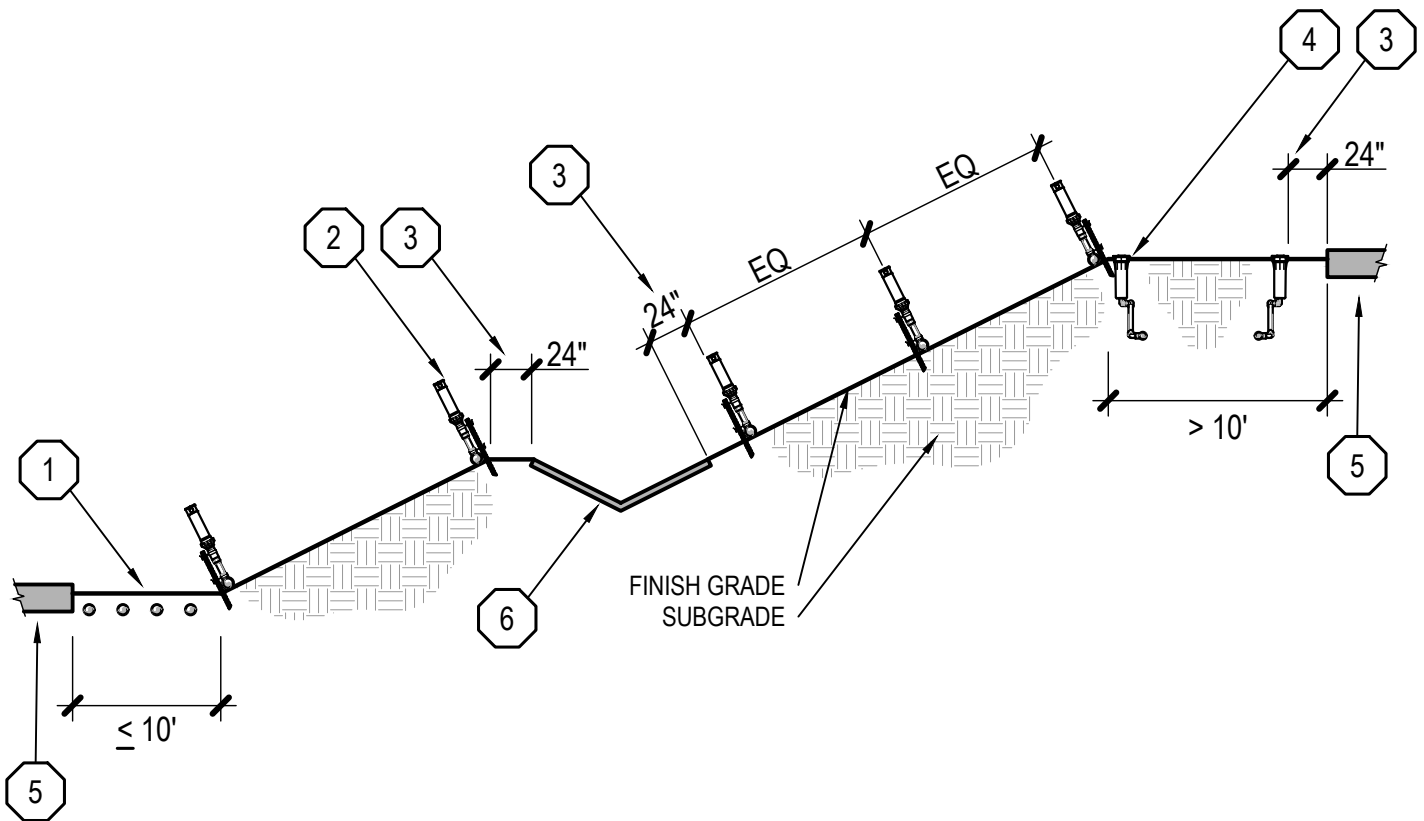

- | | |
|--|---|
| <p>① DRIP IRRIGATION</p> <p>② HEADS ON SLOPE</p> <p>③ 24" OFFSET OF OVERHEAD SPRINKLERS FROM HARDSCAPE</p> | <p>④ HEADS ON FLAT</p> <p>⑤ PERMEABLE SURFACE, HARDSCAPE OR STRUCTURE</p> <p>⑥ DRAINAGE DITCH</p> |
|--|---|

MOULTON NIGUEL WATER DISTRICT

IRRIGATION LAYOUT

IRR-26

SECTION VIEW

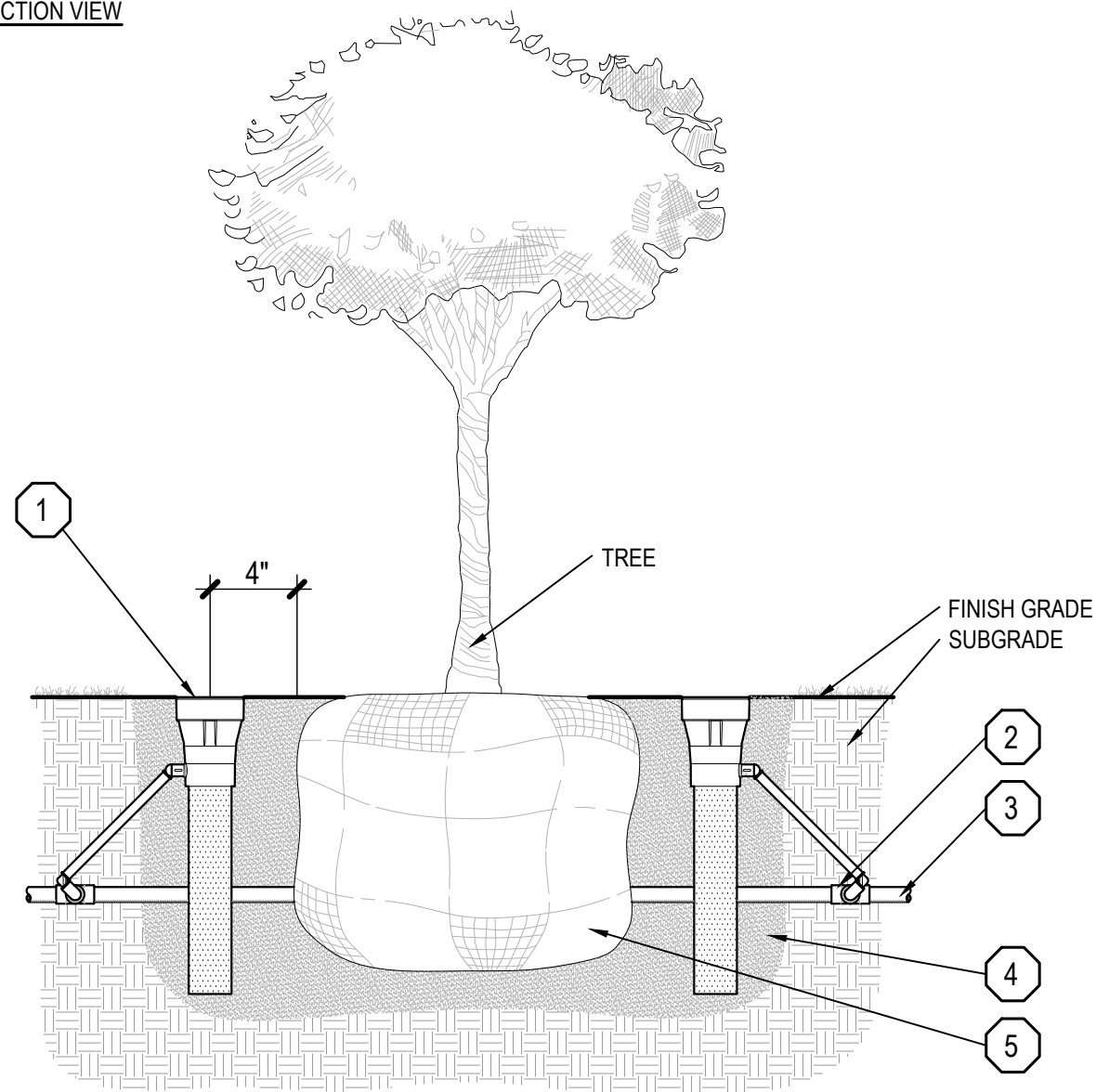

PLAN VIEW: (2) BUBBLERS PER TREE

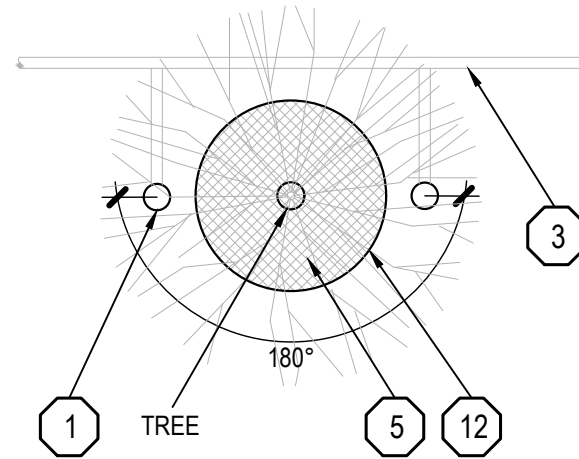

PLAN VIEW: (3) BUBBLERS PER TREE

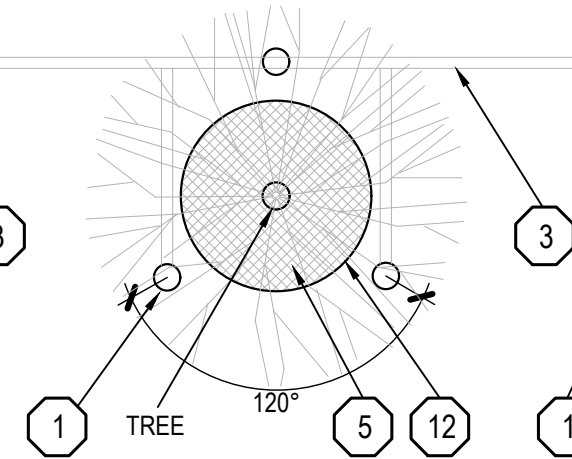

PLAN VIEW: (4) BUBBLERS PER TREE

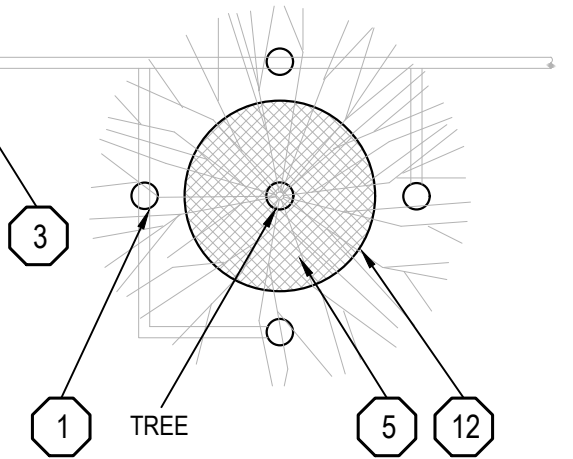

SECTION VIEW

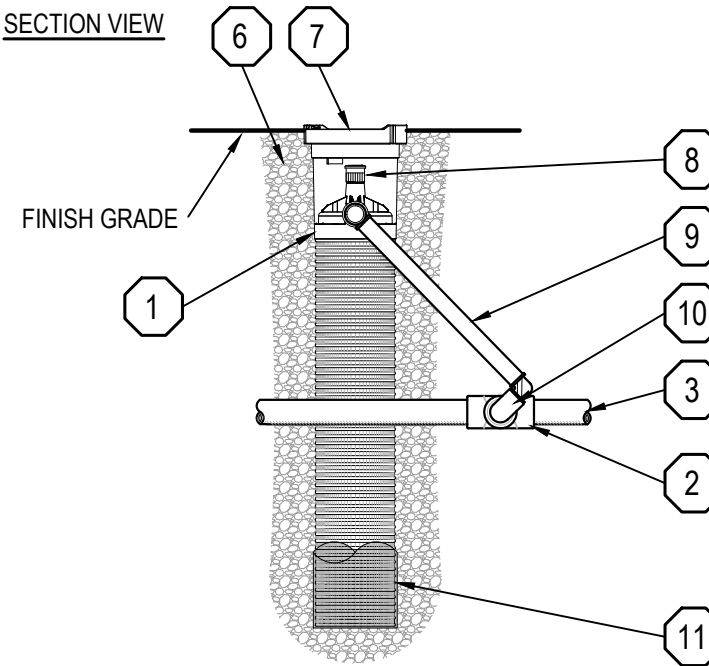

1. NOTES:
2. SPACE BUBBLERS AND TREE WELL INSPECTION TUBE EQUALLY AROUND TREE
3. ROOT WATERING BUBBLERS TO BE 90 DEGREES FROM TREE LODGE POLES
4. COORDINATE INSTALLATION OF IRRIGATION SYSTEM WITH TREE PLANTING
5. CROSS REFERENCE WITH TREE PLANTING DETAIL
6. MOULTON NIGUEL WATER DISTRICT WILL NOT BE LIABLE FOR DAMAGES THAT MAY OCCUR DUE TO THE USES OF RECYCLED WATER
7. RECYCLED WATER IDENTIFICATION REQUIRED ON ALL EMISSION DEVICES USING RECYCLED WATER. USE OF IRRIGATION MANUFACTURER'S SUPPLIED IDENTIFICATION PRODUCTS IS MANDATORY.

- | | |
|--|--|
| 1 ROOT ZONE WATERING SYSTEM | 5 ROOT BALL |
| 2 PVC SCHEDULE 40 SxSxT TEE OR 90 DEGREE ELBOW | 6 PEA GRAVEL - EVENLY DISTRIBUTE AROUND ROOT WATERING SYSTEM IN CLAY SOILS |
| 3 PURPLE LATERAL PIPE | 7 4" PURPLE GRATE |
| 4 AMENDED SOIL | 8 THREADED BUBBLER |

- | |
|--|
| 9 SWING JOINT, 12" PIPE SWING ASSEMBLY |
| 10 PVC SCHEDULE 40 STREET ELL - INLET SIZE |
| 11 4"X36" LONG RIGID BASKET WEAVE CANISTER, FILL WITH PEA GRAVEL IN HEAVY SOILS, INSTALL SOCK IN SANDY SOILS |
| 12 EDGE OF TREE PIT |

MOULTON NIGUEL WATER DISTRICT

TREE IRRIGATION

IRR-27

TUBING SPACING / OFFSET:

1. INLINE DRIP TUBING ROWS TO BE EQUALLY SPACED WITHIN LANDSCAPE AREA - REFER TO PLAN FOR ROW SPACING
2. OFFSET TUBING 12" FROM ALL BUILDINGS, STRUCTURES, WALLS AND FENCES
3. OFFSET TUBING 6" FROM ALL HARDSCAPE

NOTES:

1. ALL PLANTERS SHALL BE FEED BY A PVC HEADER CONNECTING DIRECTLY TO THE REMOTE CONTROL VALVE
2. A PVC HEADER SHALL BE INSTALLED A MINIMUM OF EVERY 150' OF DRIP TUBING OR PER MANUFACTURER SPECIFICATIONS
3. A MINIMUM OF (2) HEADER CONNECTIONS PER PLANTER ARE REQUIRED
4. INSTALL CHECK VALVE TO PREVENT LOW HEAD DRAINAGE PER DRIP MANUFACTURER SPECIFICATIONS
5. ALL TUBING SHALL BE SOLID PURPLE TO IDENTIFY RECYCLED WATER

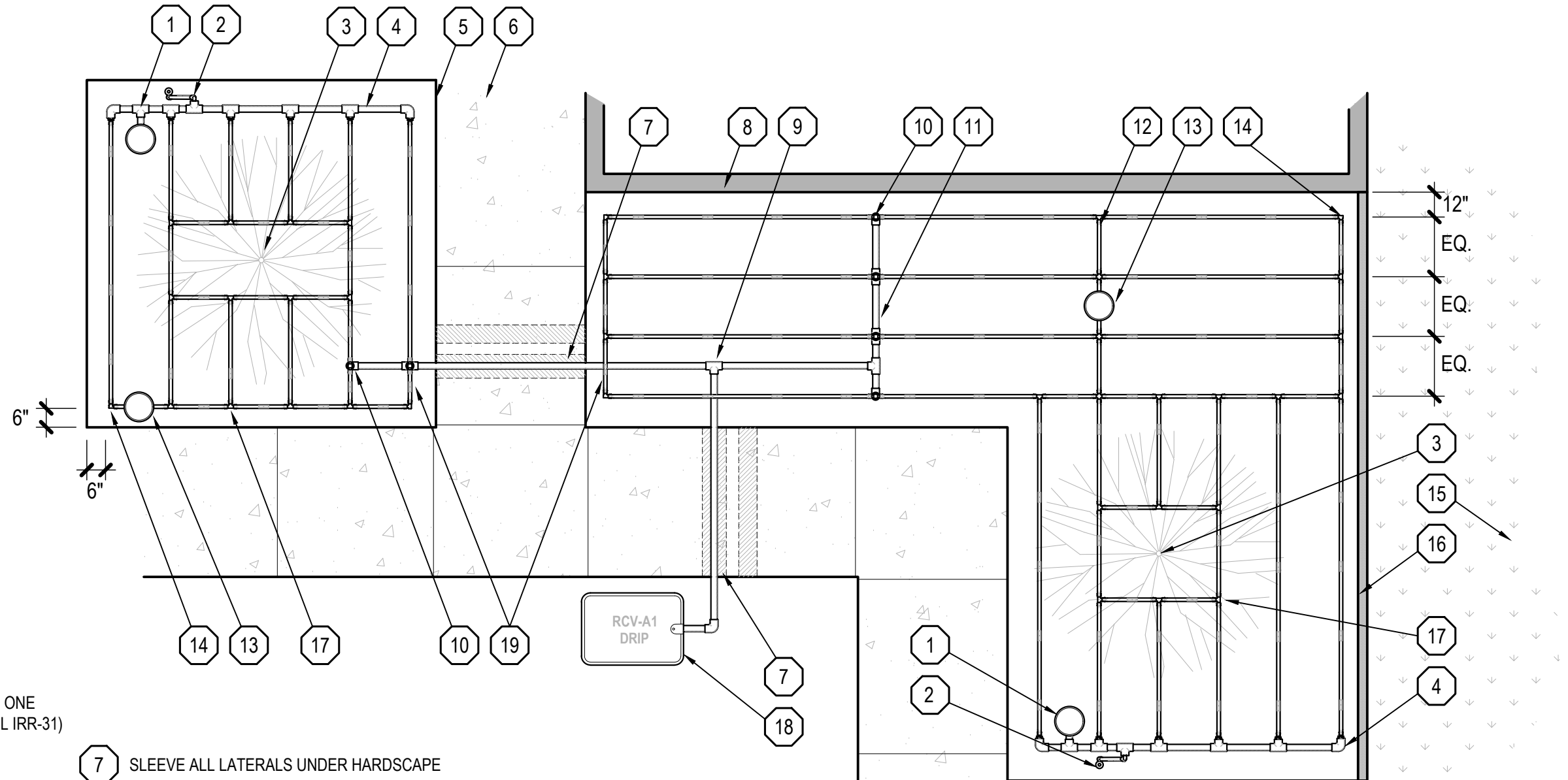

1 PURPLE FLUSH VALVE IN 6" ROUND VALVE BOX - ONE PER DETACHED PLANTER (MINIMUM) (SEE DETAIL IRR-31)

2 PURPLE DRIP INDICATOR (SEE DETAIL IRR-32)

3 TREE / OBSTRUCTION IN LANDSCAPE - DRIP TUBING SHALL BE INSTALLED AS SHOWN

4 PURPLE SCHEDULE 40 PVC FOOTER WITH BARBED 17MM X 3/4" MPT FITTING - BURIED AT DRIPLINE DEPTH, 1" MIN.

5 EDGE OF HARDSCAPE

6 HARDSCAPE

7 SLEEVE ALL LATERALS UNDER HARDSCAPE

8 BUILDING / STRUCTURE / WALL OR FENCE

9 SCHEDULE 40 PVC SLIP TEE FOR CONNECTION OF DRIP HEADER TO OTHER PLANTERS

10 BARBED 17MM X 17MM X 3/4" FPT COMBINATION TEE WITH 3/4" MALE ADAPTER

11 PURPLE SCHEDULE 40 PVC DRIP HEADER - REFER TO PLAN FOR SIZE (MINIMUM 3/4") (SEE DETAIL IRR-30)

12 AIR / VACUUM RELIEF HEADER - BLANK TUBING CONNECTING DRIP LATERAL ROWS

13 AIR / VACUUM RELIEF VALVE IN 6" ROUND VALVE BOX (SEE DETAIL IRR-38)

14 CONNECT DRIP TUBING CORNERS WITH 17MM BARBED ELL FITTING

15 TURF GRASS

16 MOW CURB

17 CONNECT DRIP TUBING ROWS WITH 17MM BARBED TEE FITTING

18 DRIP CONTROL VALVE ASSEMBLY

19 SOLID PURPLE INLINE DRIP TUBING

MOULTON NIGUEL WATER DISTRICT

INLINE DRIP LAYOUT

IRR-28

TUBING SPACING / OFFSET:

1. INLINE DRIP TUBING ROWS TO BE EQUALLY SPACED WITHIN LANDSCAPE AREA - REFER TO PLANS FOR ROW SPACING
2. OFFSET TUBING 12" FROM ALL BUILDINGS, STRUCTURES, WALLS AND FENCES
3. OFFSET TUBING 6" FROM ALL HARDSCAPE

NOTES:

1. ALL PLANTERS SHALL BE FEED BY A PVC HEADER CONNECTING DIRECTLY TO THE REMOTE CONTROL VALVE
2. A PVC HEADER SHALL BE INSTALLED A MINIMUM OF EVERY 150' OF DRIP TUBING OR PER MANUFACTURER SPECIFICATIONS
3. A MINIMUM OF (2) HEADER CONNECTIONS PER PLANTER ARE REQUIRED
4. INSTALL CHECK VALVE TO PREVENT LOW HEAD DRAINAGE PER DRIP MANUFACTURER SPECIFICATIONS
5. ALL TUBING SHALL BE SOLID PURPLE TO IDENTIFY RECYCLED WATER

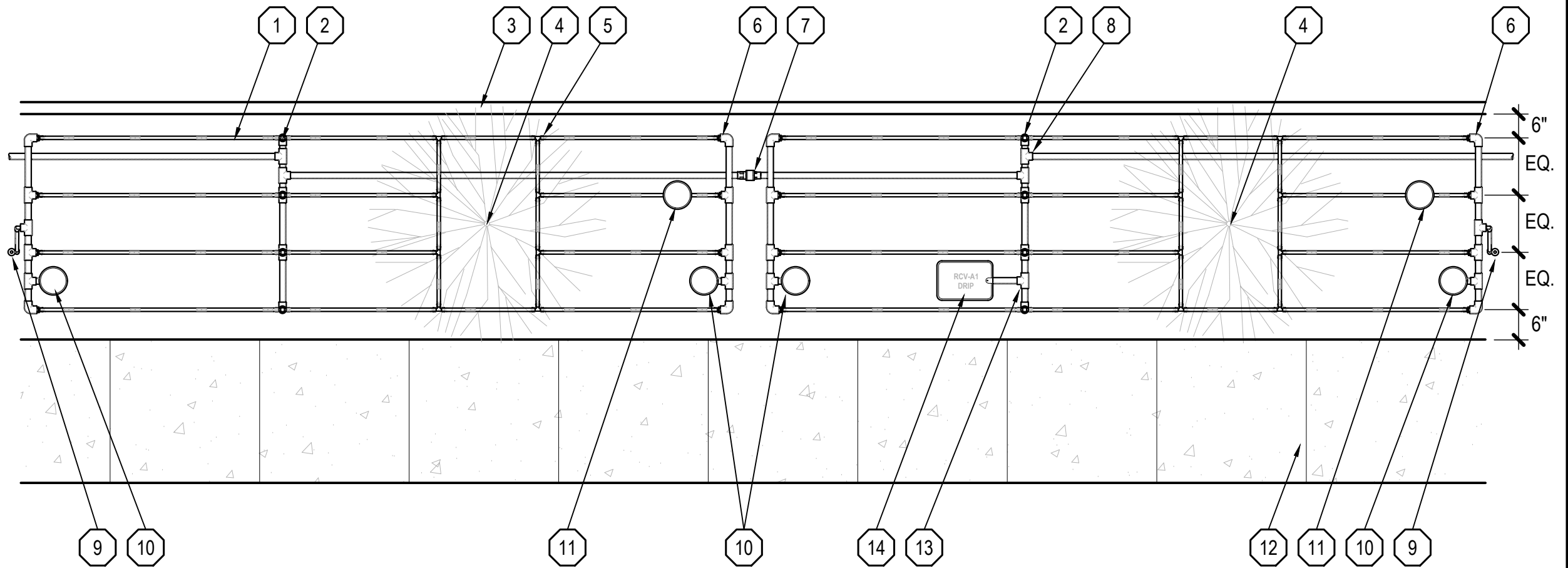

- | | | | |
|---|---|--|---|
| 1 SOLID PURPLE INLINE DRIP TUBING | 5 CONNECT DRIP TUBING ROWS WITH 17MM BARBED TEE FITTING | 9 PURPLE DRIP INDICATOR (SEE DETAIL IRR-32) | 13 PURPLE SCHEDULE 40 PVC DRIP HEADER - REFER TO PLAN FOR SIZE (MINIMUM 3/4") (SEE DETAIL IRR-30) |
| 2 BARBED 17MM X 17MM X 3/4" FPT COMBINATION TEE WITH 3/4" MALE ADAPTER | 6 PURPLE SCHEDULE 40 PVC FOOTER WITH BARBED 17MM X 3/4" MPT FITTING - BURIED AT DRIPLINE DEPTH, 1" MIN. | 10 PURPLE FLUSH VALVE IN 6" ROUND VALVE BOX - ONE PER DETACHED PLANTER (MINIMUM) (SEE DETAIL IRR-31) | 14 DRIP CONTROL VALVE ASSEMBLY |
| 3 HARDSCAPE - CURB | 7 CHECK VALVE, IF NEEDED TO PREVENT LOW HEAD DRAINAGE | 11 AIR / VACUUM RELIEF VALVE IN 6" ROUND VALVE BOX (SEE DETAIL IRR-33) | |
| 4 TREE / OBSTRUCTION IN LANDSCAPE - DRIP TUBING SHALL BE INSTALLED AS SHOWN | 8 SCHEDULE 40 PVC SLIP TEE FOR CONNECTION OF DRIP HEADER TO OTHER PLANTERS | 12 HARDSCAPE - CURB OR SIDEWALK | |

NOTES:

1. A MINIMUM OF (2) HEADER CONNECTIONS (PVC TO DRIP) PER PLANTER ARE REQUIRED
2. DRIP HEADERS ARE TO BE LOCATED IN THE CENTER OF THE DRIP ZONE WHERE POSSIBLE
3. DRIP HEADERS ARE TO AVOID TREES, UTILITIES AND OTHER OBSTRUCTIONS IN THE LANDSCAPE
4. DRIP HEADERS ARE TO BE BURIED AT A MINIMUM OF 1" BELOW FINISH GRADE, EVEN IF DRIP TUBING IS INSTALLED ABOVE GRADE. HEADER DEPTH TO MATCH DRIP DEPTH IN LEGEND

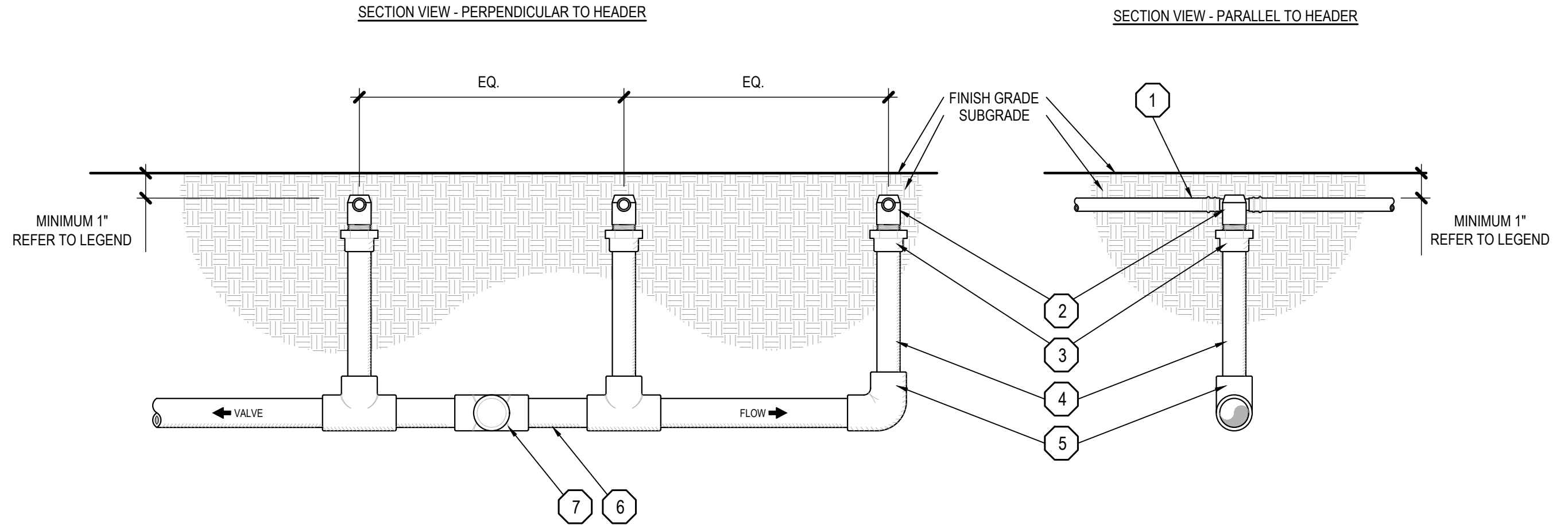

- | | | | |
|---|--|---|---|
| <p>1 SOLID PURPLE INLINE DRIP TUBING</p> <p>2 BARBED 17MM X 17MM X 3/4" FPT COMBINATION TEE</p> | <p>3 SCHEDULE 40 PVC MALE ADAPTER</p> <p>4 PURPLE 3/4" SCHEDULE 40 PVC DRIP HEADER RISER - REFER TO TRENCHING DETAIL FOR DEPTH</p> | <p>5 SCHEDULE 40 PVC SLIP TEE OR SLIP ELL CONNECTION TO DRIP HEADER RISER</p> <p>6 PURPLE SCHEDULE 40 PVC DRIP HEADER - REFER TO PLAN FOR SIZE (MINIMUM 3/4")</p> | <p>7 SCHEDULE 40 PVC SLIP TEE FOR CONNECTION OF DRIP HEADER TO OTHER PLANTERS</p> |
|---|--|---|---|

MOULTON NIGUEL WATER DISTRICT

INLINE DRIP PVC HEADER

IRR-30

NOTES:

1. DRIP FLUSH VALVES SHOWN ON IRRIGATION PLANS ARE THE MINIMUM NUMBER OF FLUSH VALVES REQUIRED. CONTRACTOR SHALL PROVIDE ADDITIONAL FLUSH VALVES AS REQUIRED

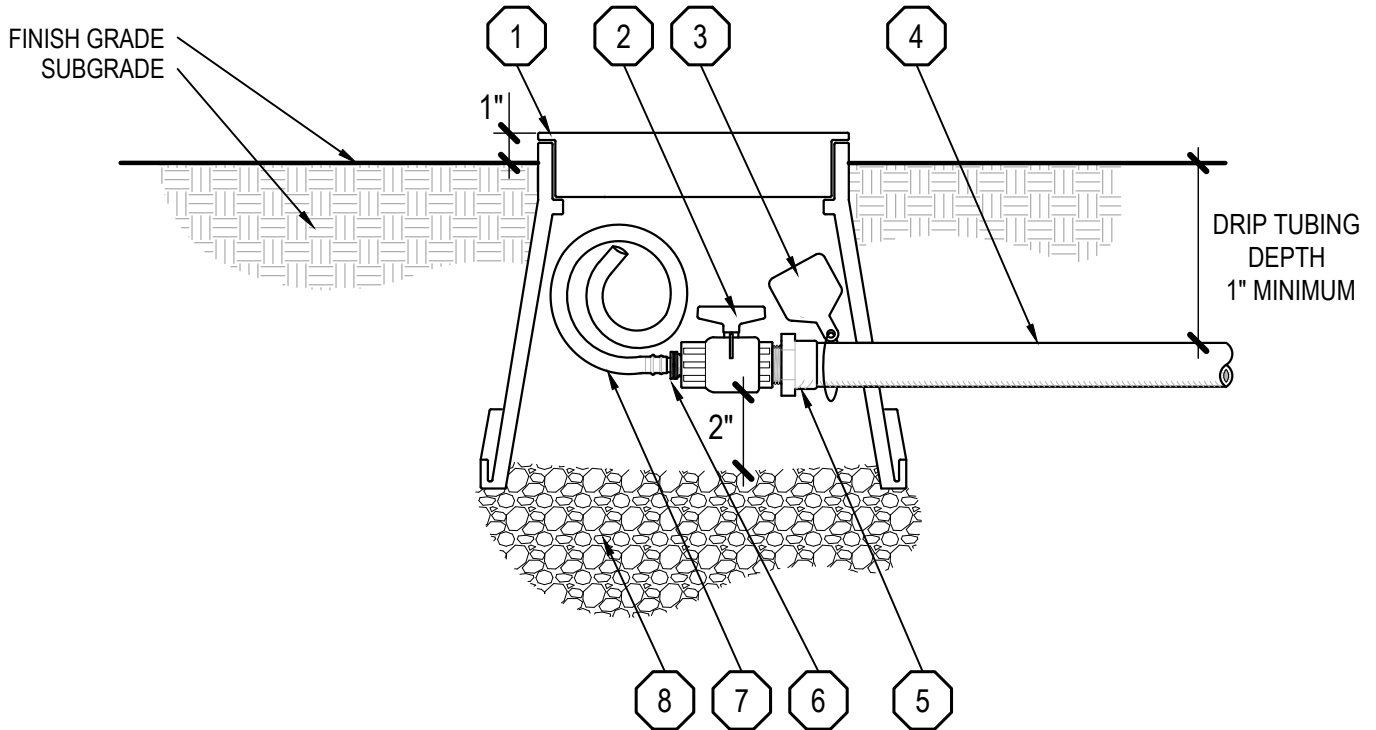

- | | | | |
|---|--|---|--------------------------------|
| 1 | 6" LOCKING ROUND VALVE BOX - (SEE DETAIL IRR-42) | 5 | SCHEDULE 40 MALE ADAPTER |
| 2 | FULL PORT PVC T x T BALL VALVE | 6 | MPT X BARBED DRIP FITTING |
| 3 | WATER IDENTIFICATION TAG - (SEE DETAIL IRR-38) | 7 | 24" PURPLE BLANK DRIP TUBING |
| 4 | PURPLE SCHEDULE 40 PVC DRIP FOOTER | 8 | 3/4" CRUSHED GRAVEL - 6" DEPTH |

MOULTON NIGUEL WATER DISTRICT

DRIP FLUSH VALVE

IRR-31

NOTES:

1. (1) INDICATOR TO BE INSTALLED ADJACENT TO EACH FLUSH VALVE (MAXIMUM 3 PER DRIP VALVE)
2. DRIP SYSTEM WITH (1) FLUSH VALVE TO HAVE AN ADDITIONAL INDICATOR LOCATED AT THE OPPOSITE END OF THE SYSTEM TO IDENTIFY THE EXTENT OF THE DRIP ZONE

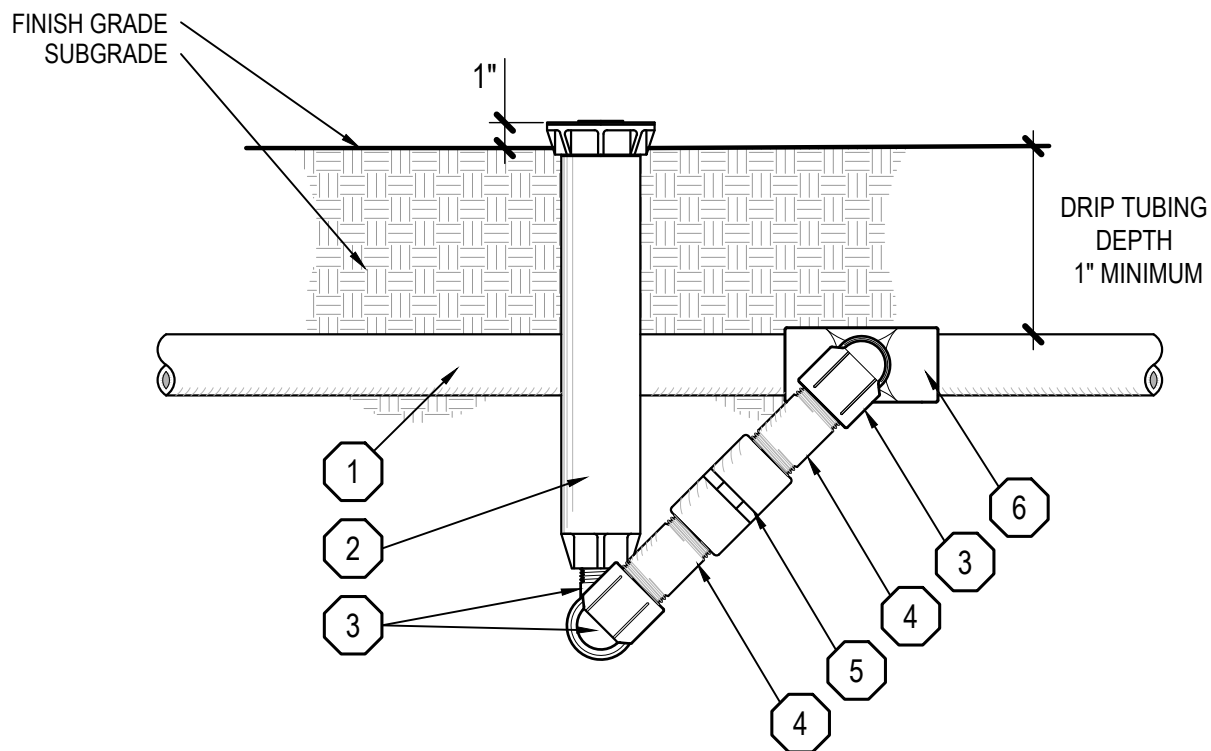

- | | |
|---|---|
| 1 PURPLE SCHEDULE 40 PVC DRIP FOOTER | 4 PVC SCHEDULE 80 NIPPLE - 4" LENGTH |
| 2 12" DRIP INDICATOR POP-UP SPRAY HEAD WITH PURPLE RISER AND SOLID PURPLE CAP | 5 PVC SCHEDULE 40 FPT x FPT CHECK VALVE |
| 3 MARLEX 90 DEGREE STREET ELBOW - INLET SIZE | 6 PVC SCHEDULE 40 SxSxT TEE OR SxT ELL |

MOULTON NIGUEL WATER DISTRICT

DRIP OPERATION INDICATOR

IRR-32

NOTES:

1. DRIP AIR RELIEF SHOWN ON IRRIGATION PLANS ARE THE MINIMUM NUMBER OF AIR RELIEF REQUIRED. CONTRACTOR SHALL PROVIDE ADDITIONAL AIR RELIEF AS REQUIRED.

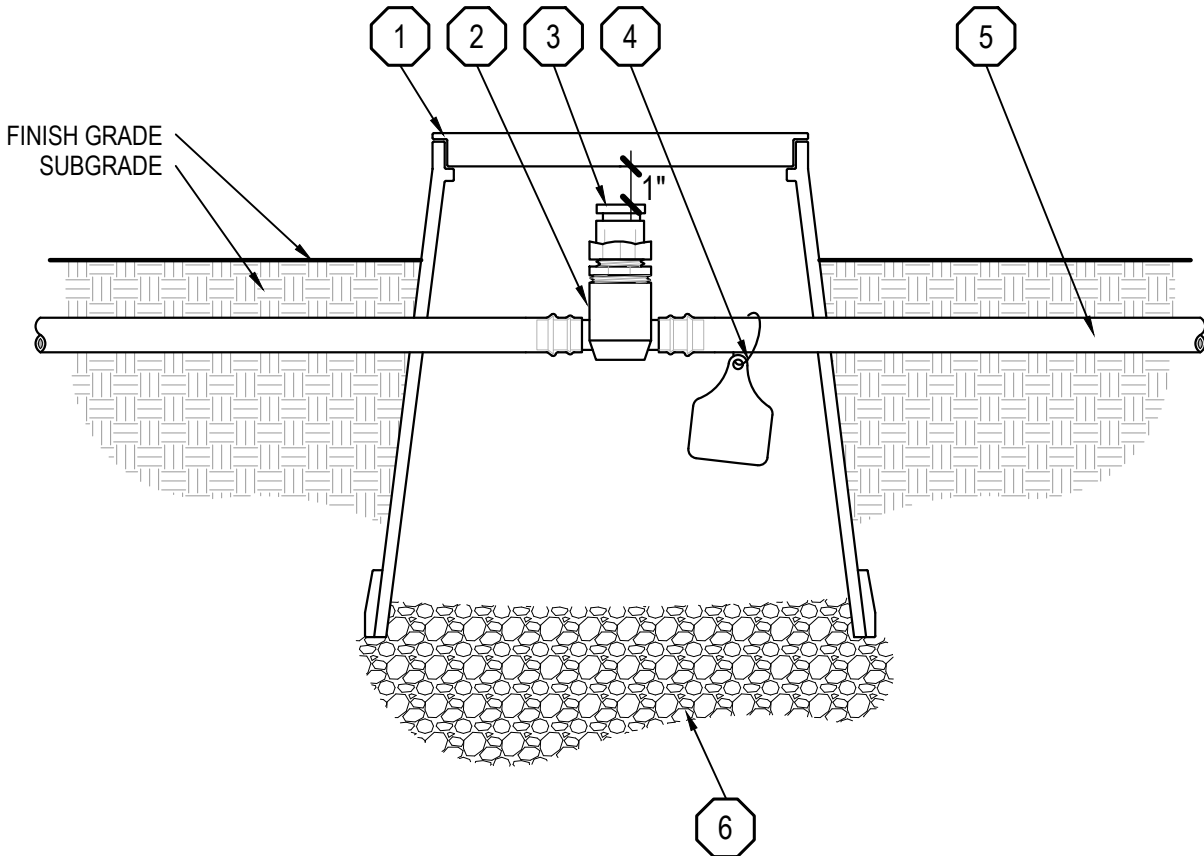

- | | | | |
|---|---|---|--|
| 1 | 6" ROUND VALVE BOX - (SEE DETAIL IRR-42) | 4 | WATER IDENTIFICATION TAG - (SEE DETAIL IRR-38) |
| 2 | BARBED 17MM X 17MM X 3/4" FPT COMBINATION TEE WITH 3/4" MPT X 1/2" FPT THREADED BUSHING | 5 | PURPLE INLINE DRIP TUBING |
| 3 | DRIP AIR / VACUUM RELIEF VALVE | 6 | 3/4" CRUSHED GRAVEL - 6" DEPTH |

MOULTON NIGUEL WATER DISTRICT

DRIP AIR RELIEF

IRR-33

NOTES:

1. SHARING A COMMON TRENCH WITH OTHER TRADES IS PROHIBITED. PROVIDE A MINIMUM OF 12" VERTICAL AND 12" HORIZONTAL SPACING FROM OTHER TRADES
2. PIPING CLASSIFICATIONS AND ASTM APPROVALS SHALL BE PLACED IN THE UPRIGHT POSITION FOR ALL PIPING
3. INSTALL CONTINUOUS TRACER WIRE BELOW MAINLINE FOR EITHER CONTROL SYSTEM - ATTACH 10' O.C.

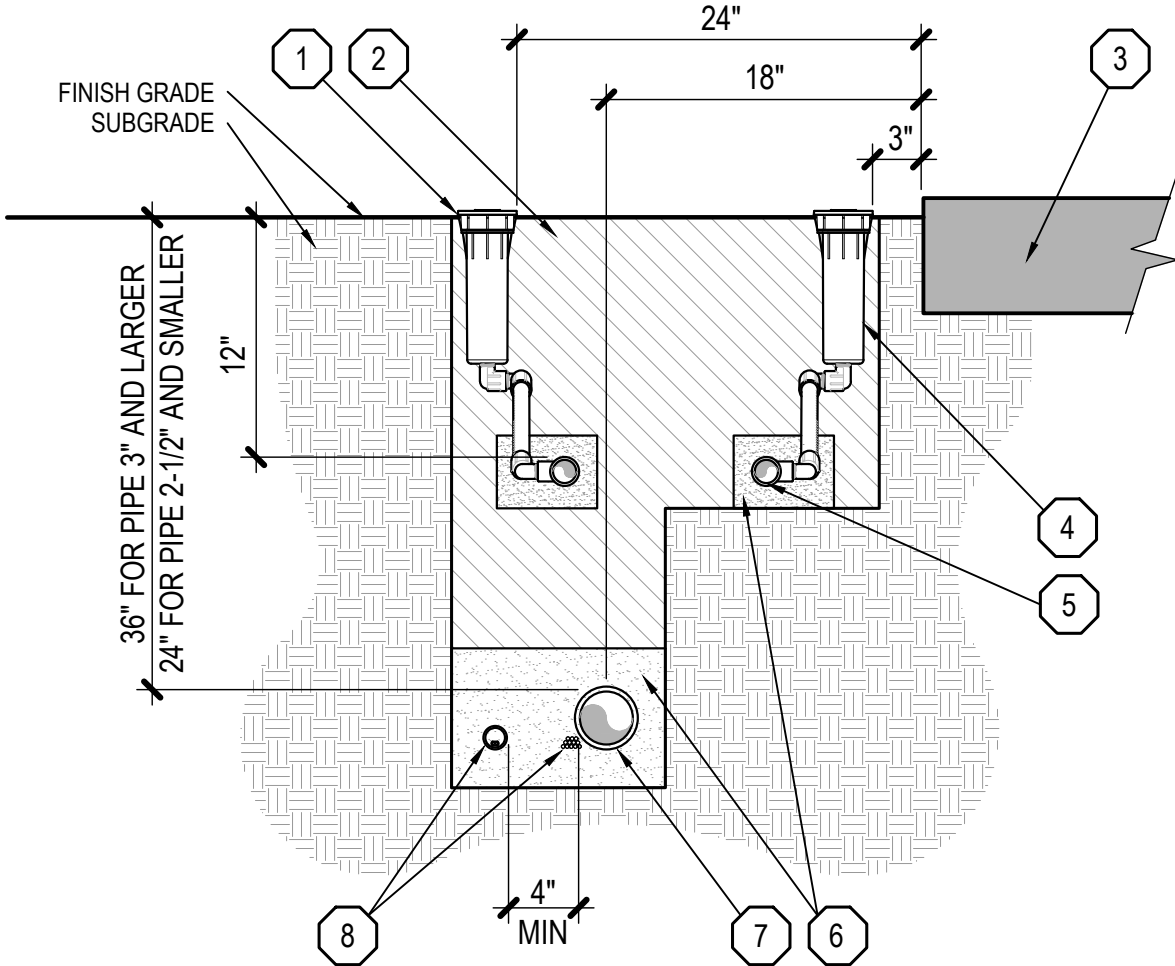

- | | |
|--|--|
| <ul style="list-style-type: none"> ① HEAD ADJACENT TO HARDSCAPE OR STRUCTURE ② COMPACTED BACKFILL ③ PERMEABLE SURFACE, HARDSCAPE OR STRUCTURE ④ HEAD ADJACENT TO PERMEABLE SURFACE | <ul style="list-style-type: none"> ⑤ LATERAL PIPE ⑥ ROCK AND DEBRIS FREE BACKFILL - MINIMUM 2" SURROUNDING PIPING ⑦ PRESSURE MAINLINE PIPE ⑧ TWO-WIRE - TWO-WIRE CABLE CONDUIT
CONVENTIONAL WIRE - VALVE WIRE BUNDLE - ATTACH TO PIPE AT 10' O.C. PROVIDE 24" EXPANSION COIL AT CHANGE IN DIRECTIONS |
|--|--|

NOTES

1. ALL SLEEVES TO BE TWICE THE DIAMETER OF PIPE / CONDUIT
2. ALL SLEEVES SHALL EXTEND MINIMUM 12" BEYOND EDGE OF HARDSCAPE / PAVING AND ENDS COVERED
3. ALL WATER PIPE SLEEVES SHALL BE IDENTIFIED (SEE DETAIL IRR-38)
4. CURBS SHALL BE MARKED AT HARDSCAPE SLEEVE CROSSINGS WITH "RWSL" IN 4" LETTERS

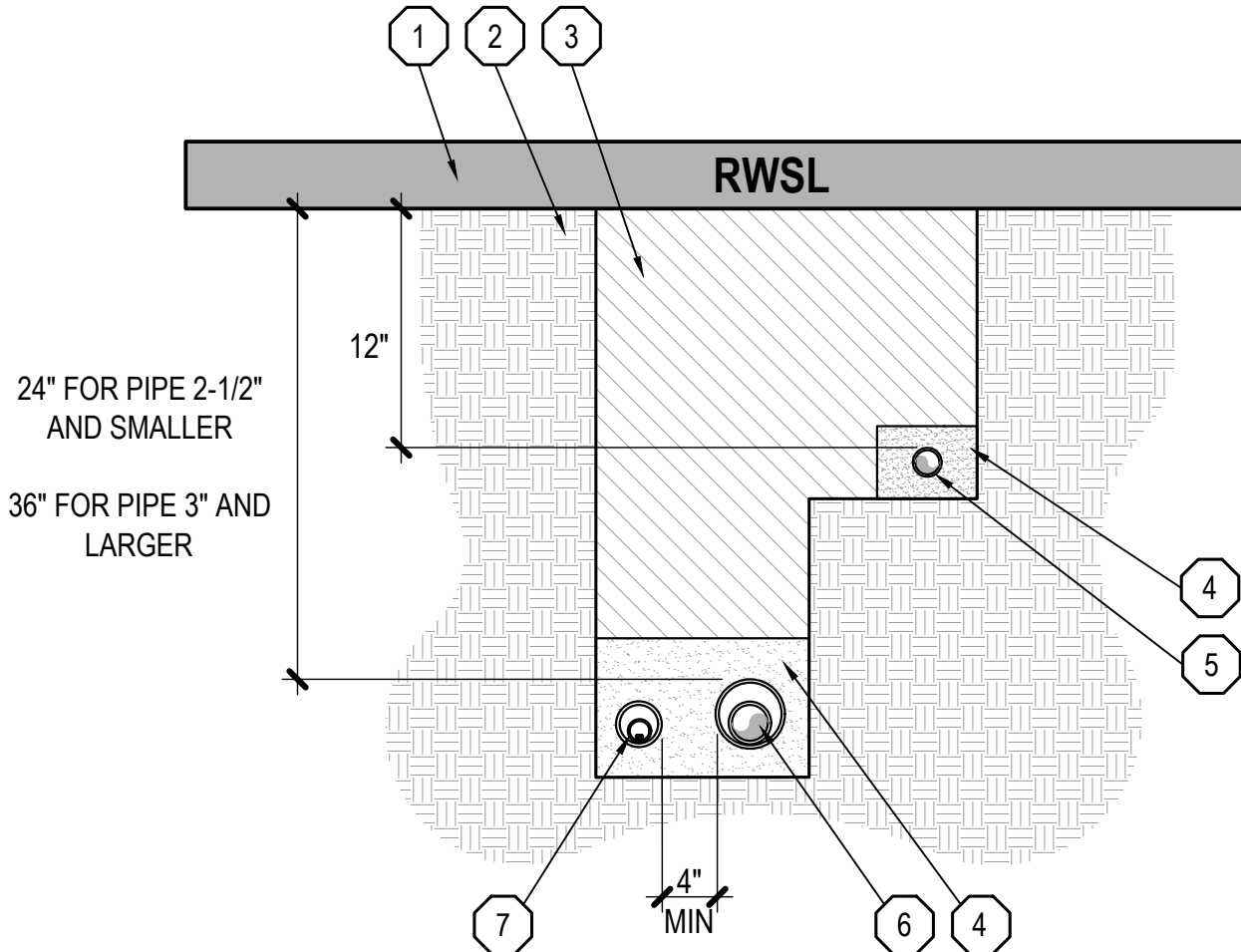

- | | |
|---|---|
| <ul style="list-style-type: none"> ① VEHICULAR PAVING OR HARDSCAPE ② SUBGRADE ③ COMPACTED BACKFILL ④ ROCK AND DEBRIS FREE BACKFILL - MINIMUM 2" SURROUNDING PIPING / SLEEVE | <ul style="list-style-type: none"> ⑤ LATERAL PIPE IN SLEEVE ⑥ PRESSURE MAINLINE PIPE IN SLEEVE ⑦ TWO-WIRE - TWO-WIRE CONDUIT IN SLEEVE - MINIMUM 2"
CONVENTIONAL WIRE - CONTROL VALVE WIRE BUNDLE IN SLEEVE - MINIMUM 2" |
|---|---|

MOULTON NIGUEL WATER DISTRICT

PIPES UNDER PAVING

IRR-35

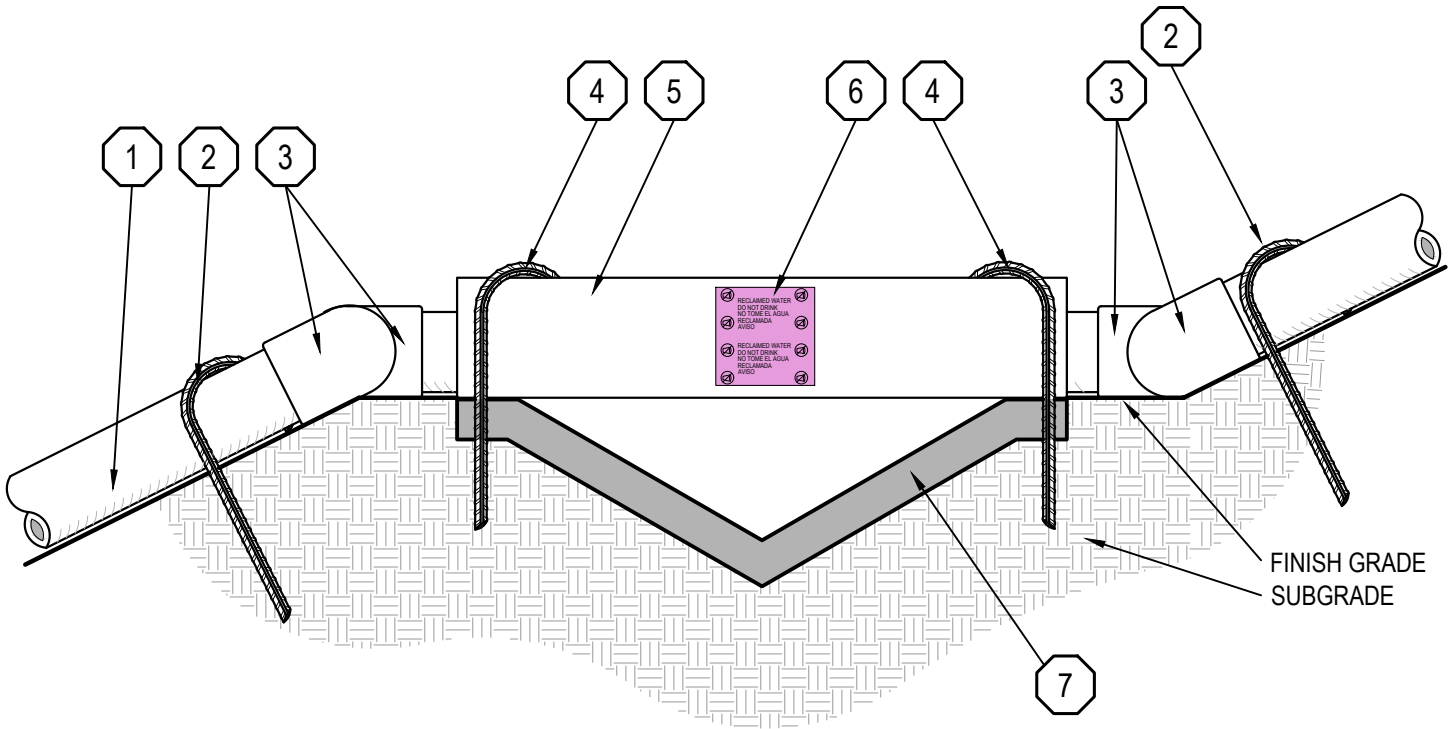

1 PIPE ON GRADE

2 18" PIPE STABILIZER - ALTERNATE DIRECTION OF PIPE STABILIZER

3 ELL FITTINGS TO ALLOW CHANGE IN DIRECTION

4 #4 REBAR SUPPORT - MINIMUM 24" LENGTH

5 SCHEDULE 40 GALVANIZED STEEL SLEEVE - BURR FREE WITH NO SHARP EDGES

6 (2) WATER IDENTIFICATION STICKER

7 DRAINAGE DITCH - PER CIVIL PLAN

MOULTON NIGUEL WATER DISTRICT

TERRACE DRAIN CROSSING

IRR-36

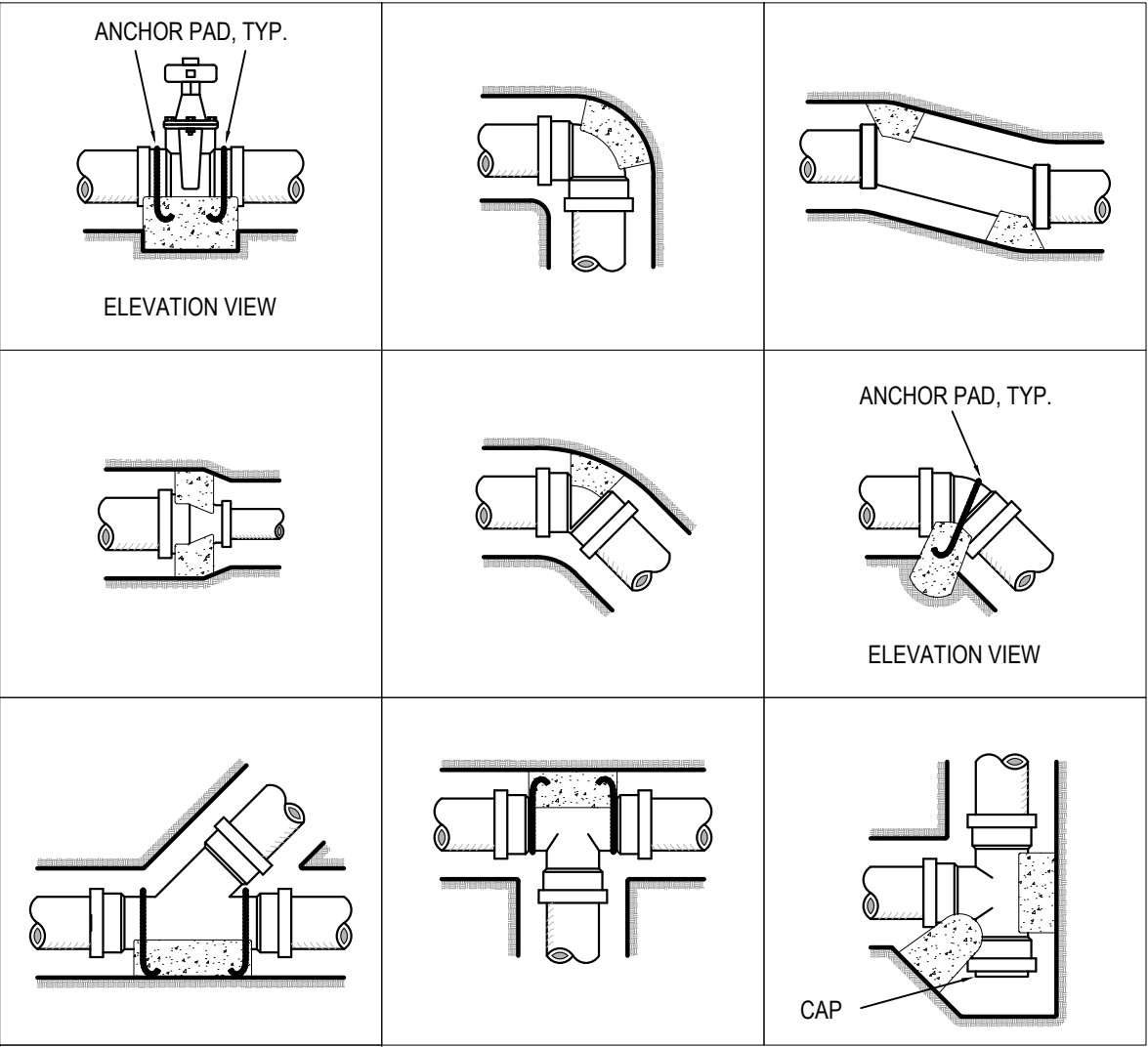

NOTES:

1. ALL RING-TITE OR SOLVENT WELDED PLASTIC PIPE TO BE INSTALLED ACCORDING TO THESE DETAILS UNLESS OTHERWISE NOTED OR DETAILED AS DIRECTED BY MNWD
2. ALL ANCHOR RODS SHALL BE GALVANIZED STEEL, MINIMUM 1/2 INCH DIAMETER, WRAPPED AROUND PIPE
3. SIZE OF THRUST BLOCKS SHALL BE SPECIFIED ON PLANS OR AS DIRECTED BY MNWD
4. ALL VIEWS ARE PLAN VIEW UNLESS OTHERWISE NOTED
5. THRUST BLOCKS REQUIRED ON SIZES 2" OR GREATER OR AS REQUIRED BY MNWD

MOULTON NIGUEL WATER DISTRICT

THRUST BLOCKS

IRR-37

ABOVE GROUND PIPING LABELS

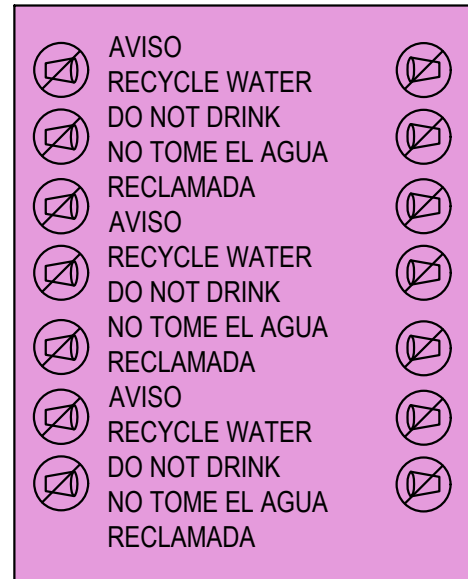

PURPLE



GREEN

RECYCLED AND POTABLE IRRIGATION SIGNS



*PROVIDED BY MNWD

TAGS

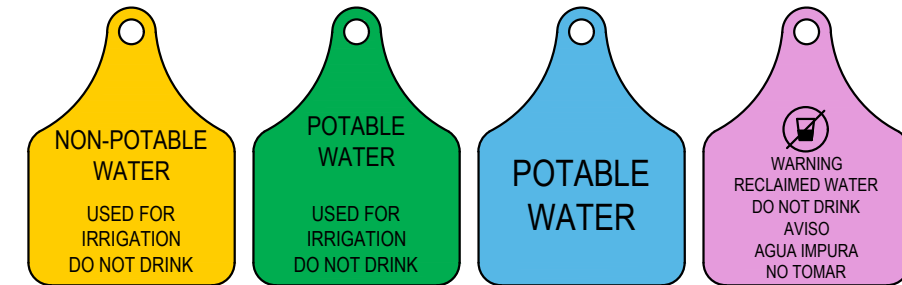

YELLOW

GREEN

BLUE

PURPLE



PIPING TAPE



YELLOW

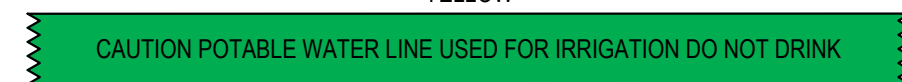

GREEN

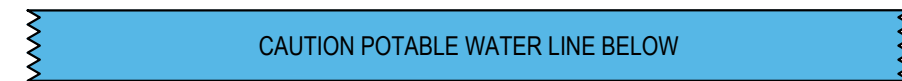

BLUE

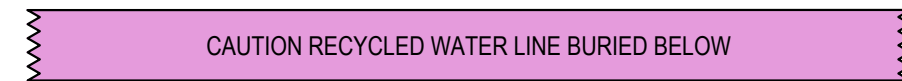

PURPLE

USE IDENTIFICATION MATERIALS ABOVE OR APPROVED EQUAL

NOTE:

1. MNWD SHALL FURNISH ONE SIGN PER CONTROLLER MINIMUM. CONTRACTOR SHALL INSTALL ADDITIONAL SIGNS AS REQUIRED BY MNWD INSPECTOR

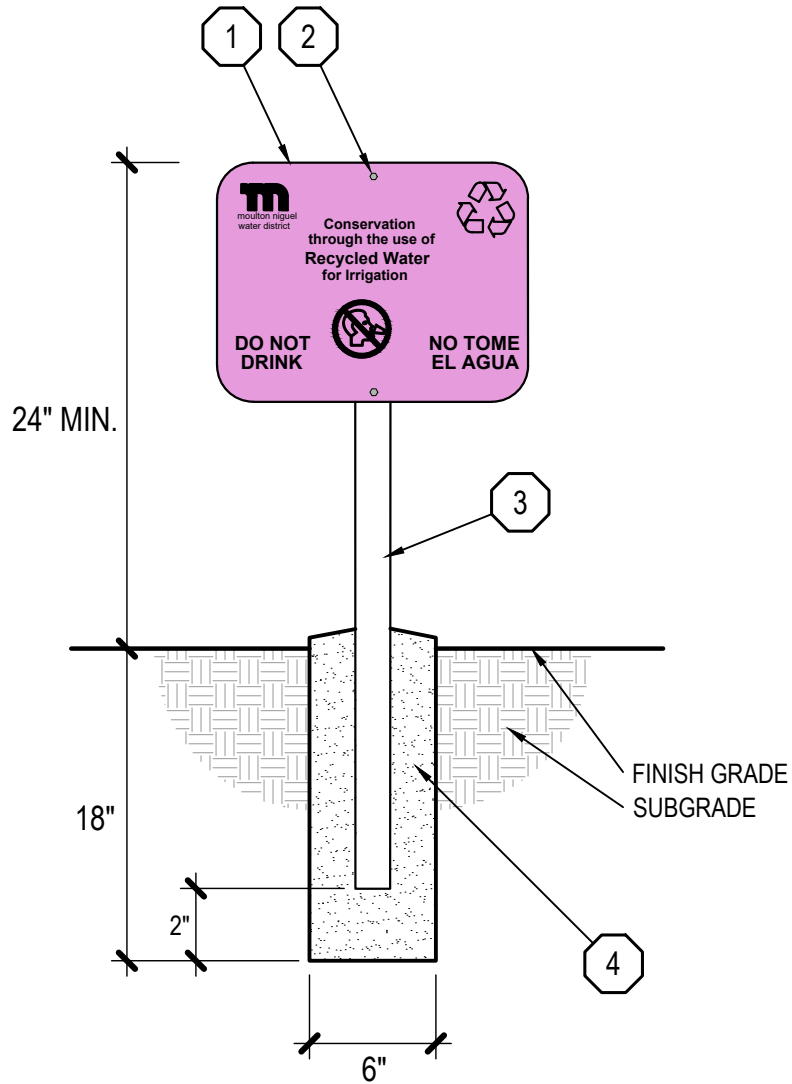

1 RECYCLED WATER SIGN

3 1-1/2" SQ (1/16" WALL)

2 ATTACH SIGN TO POST WITH (2) STAINLESS STEEL BOLTS

4 CONCRETE SIGN BASE - SLOPE 2% FOR DRAINAGE

MOULTON NIGUEL WATER DISTRICT
 RECYCLED WATER IDENTIFICATION SIGN

IRR-39

CROSSING CONDITION

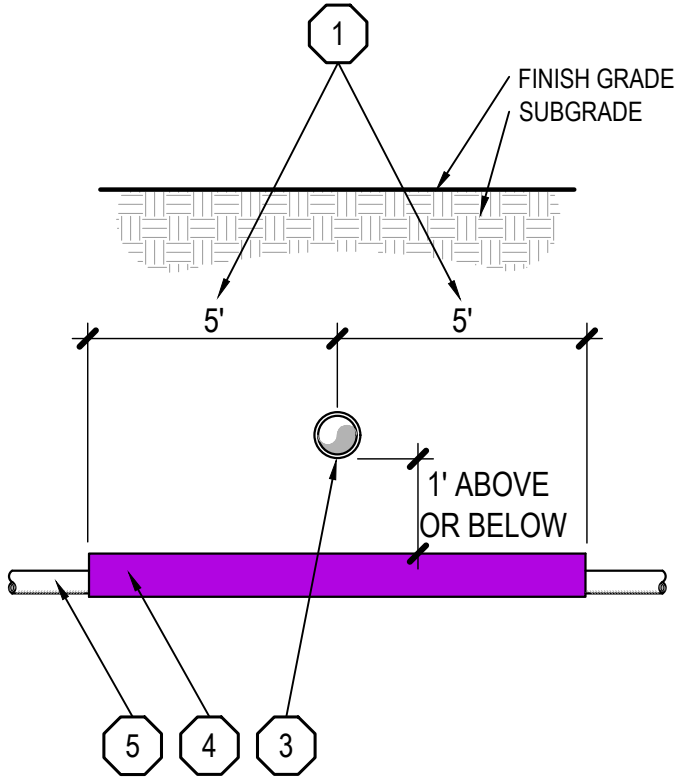

PARALLEL CONDITION

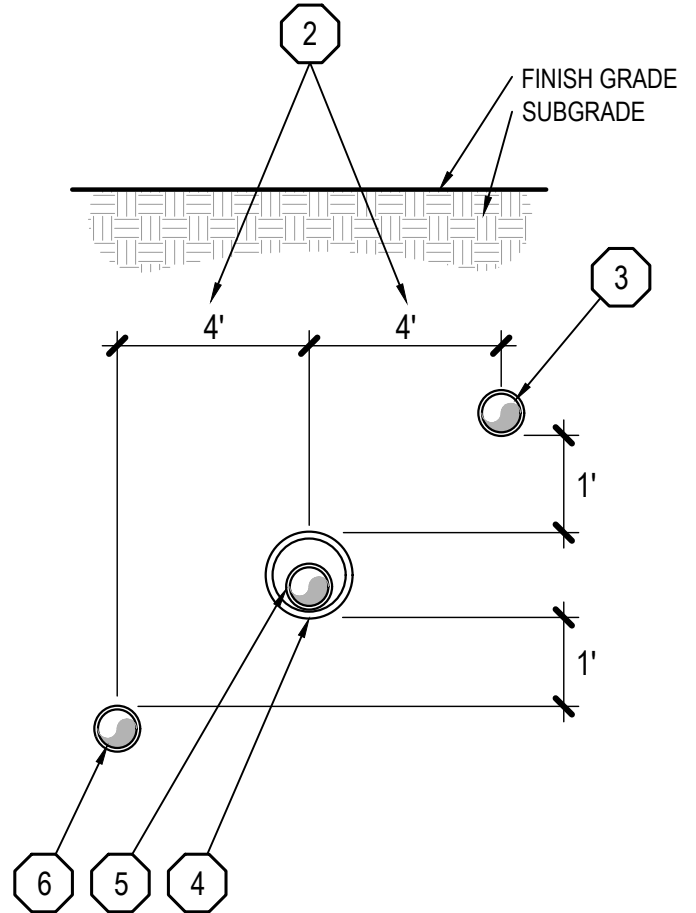

NOTE:

1. CONTRACTOR TO COORDINATE CROSSINGS WITH WATER DISTRICT INSPECTOR PRIOR TO TRENCHING

- | | | | |
|---|--|---|---|
| 1 | RECYCLED WATER MAINLINE TO BE SLEEVED WITHIN 10' OF POTABLE WATER CROSSING | 4 | RECYCLED WATER MAINLINE SLEEVE |
| 2 | RECYCLED WATER MAINLINE PIPE TO BE SLEEVED WITHIN 4' OF POTABLE WATER PIPE / EQUIPMENT | 5 | RECYCLED WATER MAINLINE PIPE - MIN 20' CENTERED |
| 3 | POTABLE WATER PIPE | 6 | SANITARY SEWER PIPE |

MOULTON NIGUEL WATER DISTRICT
SEPARATION OF DW / RW MAINLINES

IRR-40

NOTES:

1. ALL STABILIZER ASSEMBLIES SHALL BE PLACED ON THE DOWNHILL SIDE OF PIPING
2. FOR VERTICAL SLOPE INSTALLATION, INSTALL STABILIZER ASSEMBLIES ON ALTERNATING SIDES OF PIPE

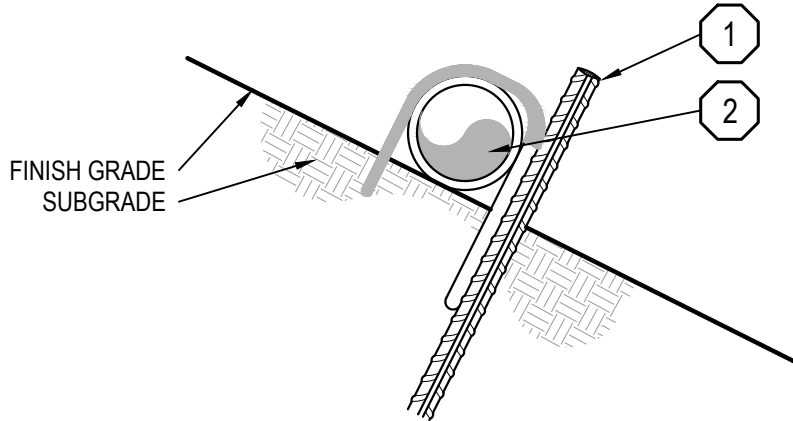

SECTION

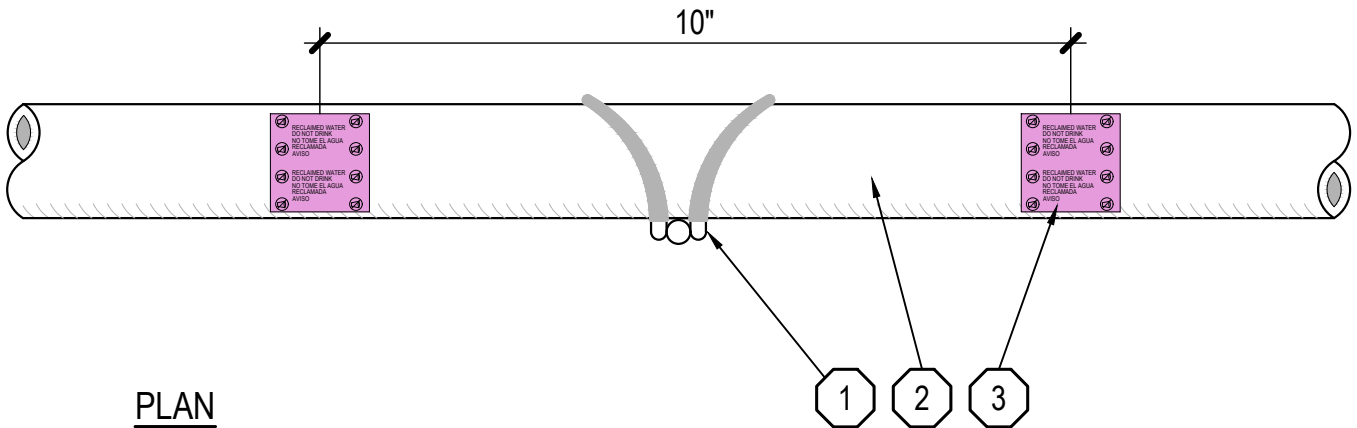

PLAN

1 18" PIPE STABILIZER - 8' O.C. FOR MAINLINE / 10' O.C. FOR LATERALS

2 PIPE ON GRADE

3 WATER IDENTIFICATION STICKER - SPACING 10' O.C.

MOULTON NIGUEL WATER DISTRICT

PIPE STABILIZER ON GRADE

IRR-41

NOTE:

- CONTRACTOR TO USE 2" BRANDING KIT FOR BRANDING VALVE BOXES

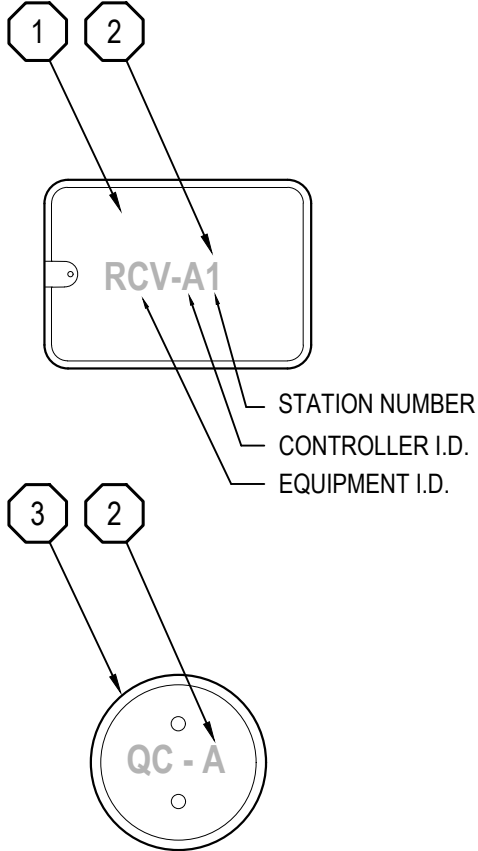

BOX COLOR	EQUIPMENT:	CONTROLLER:	BRANDING:
DOMESTIC WATER - GREEN RECYCLED WATER - PURPLE	AIR RELIEF VALVE	A	AR - A
	BALL VALVE	A	BV - A#
	BASKET STRAINER	A	BS - #
	CONTROL VALVE	A	RCV - A#
	DRIP AIR RELIEF	A	AR - #
	DRIP FLUSH VALVE	A	FV - #
	FERTILIZER INJECTOR	A	FI - A
	FLOW SENSOR	A	FS - A
	GATE VALVE	A	GV - A
	MASTER VALVE	A	MV - A
	PRESSURE REGULATOR	A	PR - A
	QUICK COUPLER	A	QC - A
	BLACK	GROUND ROD	A
WIRING PULL BOX		A	PB - A
SURGE ARRESTOR		A	SA - A

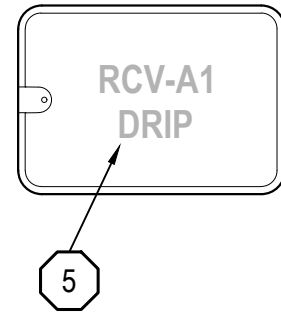
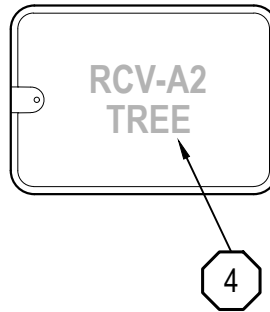

- 1 LOCKING RECTANGULAR VALVE BOX
- 2 2" VALVE BOX BRAND
- 3 LOCKING ROUND VALVE BOX

- 4 IF RCV IS A TREE VALVE, THEN BRAND "TREE" BELOW RCV-A# BRANDING
- 5 IF RCV IS A DRIP VALVE, THEN BRAND "DRIP" BELOW RCV-A# BRANDING

NOTE:

1. VALVE BOXES SHALL BE LOCATED OUTSIDE OF TURF AREAS
2. VALVE BOXES SHALL NOT BE LOCATED ADJACENT TO TREES OR UTILITIES

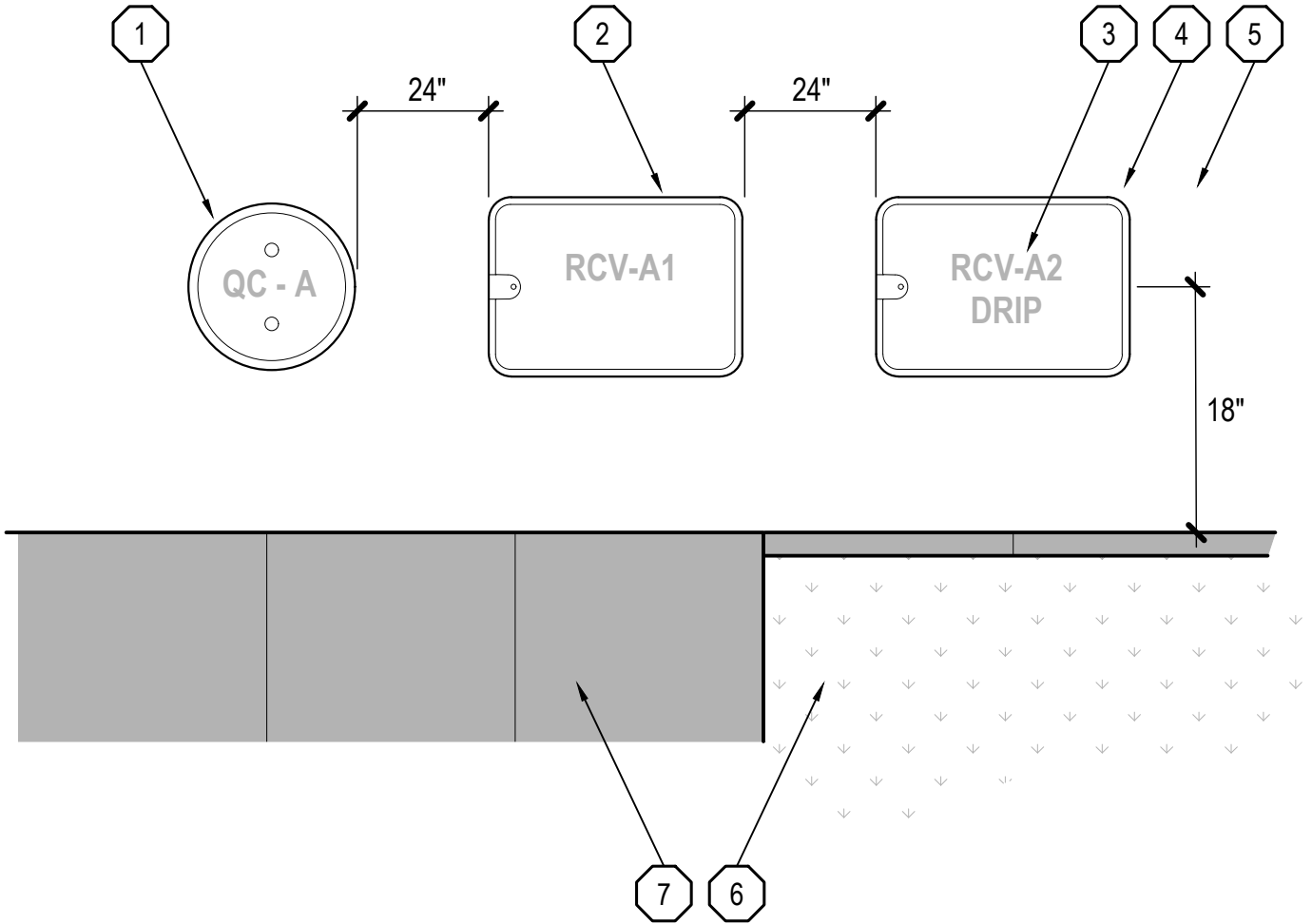

- | | |
|--|--|
| <ul style="list-style-type: none"> 1 LOCKING ROUND VALVE BOX 2 LOCKING RECTANGULAR VALVE BOX 3 2" VALVE BOX BRAND - (SEE DETAIL IRR-42) 4 ALIGN VALVE BOXES PARALLEL TO LANDSCAPE EDGE HARDSCAPE | <ul style="list-style-type: none"> 5 SHRUB LANDSCAPE AREA 6 TURF LANDSCAPE AREA 7 HARDSCAPE OR STRUCTURE |
|--|--|

MOULTON NIGUEL WATER DISTRICT	IRR-43
VALVE BOX LAYOUT	

ELEVATION

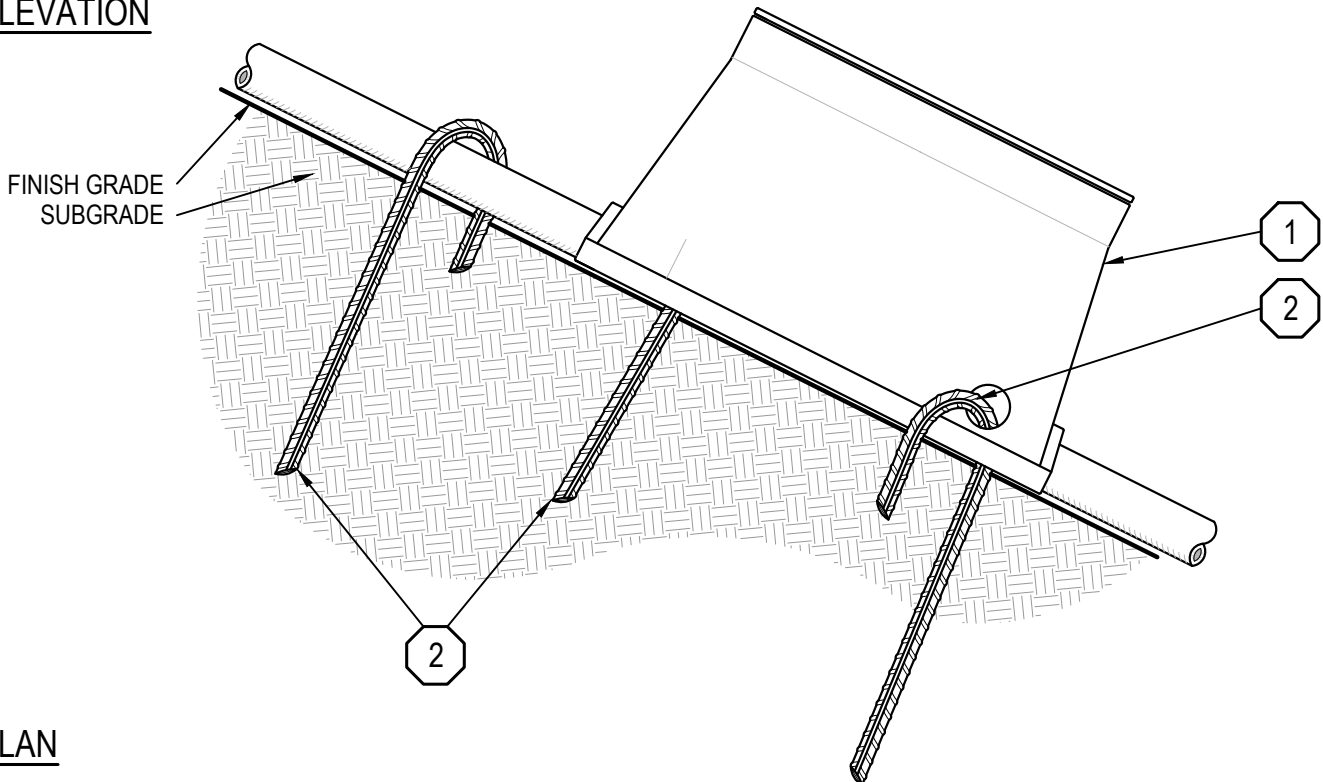

PLAN

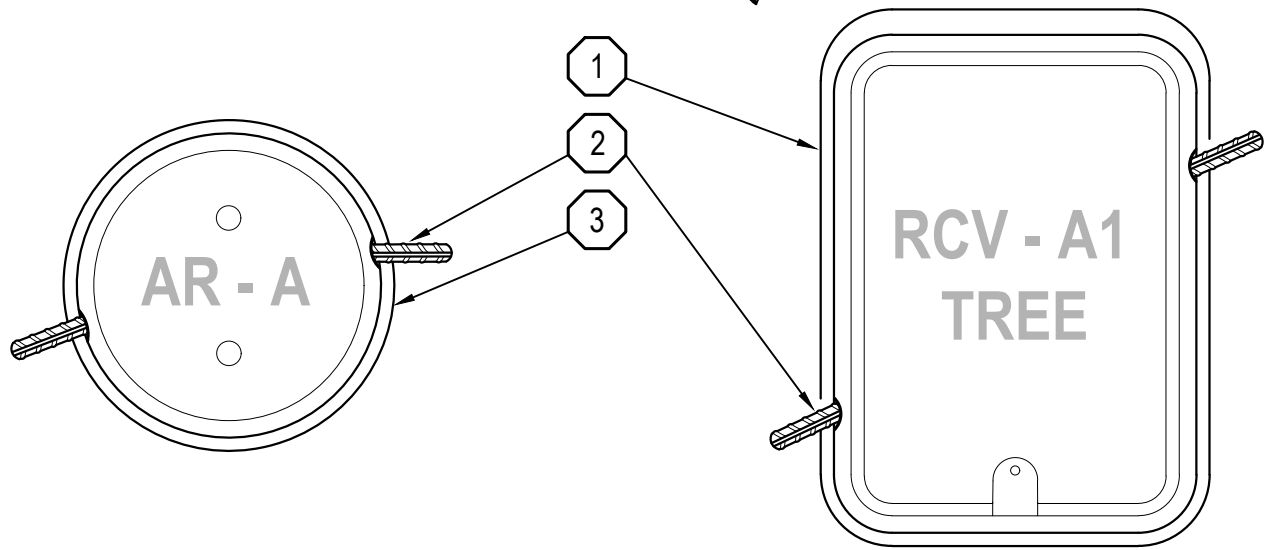

1 LOCKING RECTANGULAR VALVE BOX
(SEE DETAIL IRR-42)

3 LOCKING ROUND VALVE BOX - (SEE DETAIL IRR-42)

2 #4 REBAR - MINIMUM 18" LENGTH - INSTALL LONG END ON
INSIDE OF BOX THROUGH 1" HOLE IN THE SIDE OF BOX

MOULTON NIGUEL WATER DISTRICT

VALVE BOX ON SLOPE

IRR-44

NOTE:

1. LOCATE RAIN SENSOR AWAY FROM VIEW WITHOUT OBSTRUCTIONS FROM THE SKY

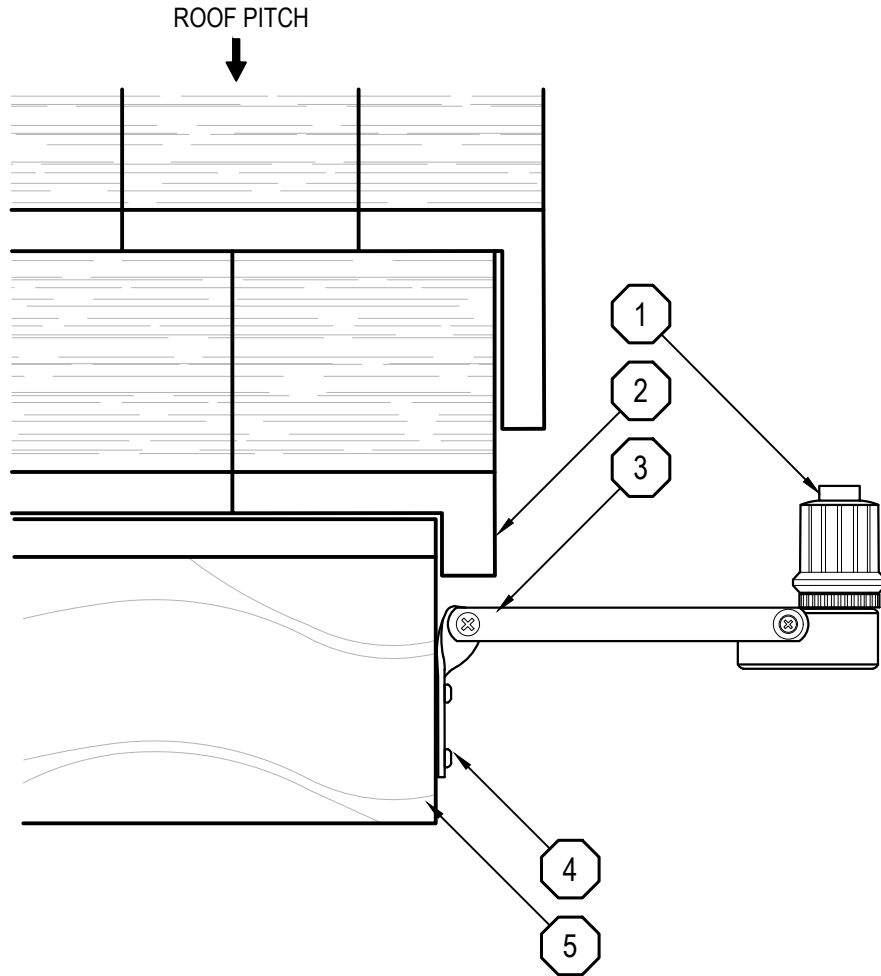

1 RAIN / WEATHER SENSOR

2 ROOF MATERIAL

3 SENSOR MOUNTING BRACKET - SUPPLIED WITH SENSOR

4 STAINLESS STEEL MOUNTING HARDWARE

5 ROOF EAVE

MOULTON NIGUEL WATER DISTRICT

RAIN SENSOR

IRR-45

CALIFORNIA AB1881

MODEL WATER EFFICIENT LANDSCAPE ORDINANCE COMPLIANCE

IRRIGATION PLANS SUBMITTED TO MOULTON NIGUEL WATER DISTRICT SHALL COMPLY WITH CALIFORNIA AB1881 REQUIREMENTS.

IRRIGATION PLANS SHALL PROVIDE (BUT ARE NOT LIMITED TO) THE FOLLOWING:

1. **SMART IRRIGATION CONTROLLER** - ADJUSTS VIA CURRENT WEATHER CONDITIONS OR SOIL MOISTURE SENSING. IF SMART CONTROLLER HAS COMMUNICATIONS, CONTRACTOR TO HAVE COMMUNICATIONS ACTIVATED BEFORE CERTIFICATE OF COMPLETION.
2. **FLOW SENSING** - IRRIGATION CONTROLLERS ARE TO PROVIDE FLOW SENSING BY STATION. IRRIGATION CONTROLLERS ARE TO PROVIDE THE FOLLOWING FLOW SENSING ALERTS TO THE USER:
 - STATION - NO FLOW ALERT
 - STATION - LOW FLOW ALERT
 - STATION - HIGH FLOW ALERT
 - MAINLINE - NO FLOW ALERT
 - MAINLINE - HIGH FLOW ALERTCONTRACTOR TO HAVE FLOW SENSING OPERATIONAL, FLOW LEARNED BY STATION WITH ALERTS ACTIVATED BEFORE CERTIFICATE OF COMPLETION.
3. **MASTER VALVE** - A MASTER VALVE IS TO BE INSTALLED AND OPERATIONAL ON THE IRRIGATION SYSTEM TO PROVIDE PROTECTION FROM LEAKS AND BREAKS.
4. **RAIN SENSOR** - A RAIN SENSOR WITH A MINIMUM OF 48 HOUR RAIN DELAY TO BE INSTALLED AND ACTIVATED ON THE SMART IRRIGATION CONTROLLER.
5. **OVER SPRAY / RUN OFF** - IRRIGATION SYSTEM SHALL HAVE NO OVERSPRAY / RUN OFF
 - LANDSCAPE AREAS LESS THAN 10' WIDE SHALL BE IRRIGATED WITH DRIP IRRIGATION
 - SPRINKLERS SHALL HAVE A 24" OFFSET FROM HARDSCAPE

*REFER TO CALIFORNIA 1881 MODEL WATER EFFICIENT LANDSCAPE ORDINANCE FOR ADDITIONAL CURRENT IRRIGATION REQUIREMENTS.

<p>Water Efficient Landscape Compliance Note</p> <p>I HAVE COMPLIED WITH THE CRITERIA OF THE WATER EFFICIENT LANDSCAPE ORDINANCE AND APPLIED THEM ACCORDINGLY FOR THE EFFICIENT USE OF WATER IN THE LANDSCAPE DESIGN PLANS.</p> <p>SIGNATURE _____ Date _____</p>

PLACE SIGNED WATER EFFICIENT LANDSCAPE COMPLIANCE BLOCK ON FIRST SHEET OF IRRIGATION PLANS

MOULTON NIGUEL WATER DISTRICT

MWELO COMPLIANCE NOTES

IRR-46

MOULTON NIGUEL WATER DISTRICT STANDARD NOTES

1. THE DESIGN, INSTALLATION, IDENTIFICATION AND USE OF ALL ONSITE POTABLE WATER SYSTEMS, FIRE PROTECTION SYSTEMS, POTABLE WATER USED FOR IRRIGATION SYSTEMS AND RECYCLED WATER IRRIGATION SYSTEMS SHALL CONFORM TO ALL STATE, COUNTY, ANWA, SOGWA AND DISTRICT RULES, REGULATIONS, GUIDELINES, ARTICLES AND CODES REGARDING THE DESIGN, INSTALLATION, IDENTIFICATION, USE AND MAINTENANCE OF ONSITE SYSTEMS AND PROTECTION OF THE PUBLIC'S HEALTH. THE CONTRACTOR SHALL HAVE A COPY OF THESE PLANS AND THE DISTRICT STANDARD SPECIFICATIONS ON THE JOB AT ALL TIMES.
2. NO CONSTRUCTION SHALL TAKE PLACE WITHOUT ALL REQUIRED APPROVALS AND SIGNATURES ON THE PLANS.
3. THE DISTRICT SHALL BE FURNISHED WITH TWO (2) COPIES OF THE APPROVED CONSTRUCTION PLANS PRIOR TO STARTING CONSTRUCTION. A MANDATORY PRE-CONSTRUCTION MEETING SHALL BE HELD ON THE JOB SITE A MINIMUM OF 24 HOURS PRIOR TO THE START OF CONSTRUCTION. NO WORK SHALL TAKE PLACE WITHOUT A PRE-CONSTRUCTION MEETING ONSITE.
4. THE DISTRICT'S INSPECTOR SHALL BE NOTIFIED A MINIMUM OF TWO DAYS (48 HOURS) PRIOR TO CONSTRUCTION, OR ANY INSPECTION.
5. ALL POTABLE AND RECYCLED WATER METERS, BACKFLOW ASSEMBLIES, AND RELATED APPURTENANCES SHALL BE INSTALLED, INSPECTED, AND TESTED PER DISTRICT SPECIFICATIONS BEFORE ANY RECYCLED WATER USE CAN TAKE PLACE.
6. ONSITE SEPARATION REQUIREMENTS:
HORIZONTAL SEPARATION: THE PRESSURIZED RECYCLED WATER PIPING SHALL MAINTAIN A FOUR (4) FOOT HORIZONTAL SEPARATION AT ALL TIMES FROM ALL POTABLE WATER PIPING AND/OR A PARALLEL SANITARY SEWER SYSTEM. IF A 4-FOOT HORIZONTAL SEPARATION IS NOT POSSIBLE, SPECIAL CONSTRUCTION REQUIREMENTS SHALL BE CONSIDERED, REFER TO DISTRICT STANDARD DETAIL DRAWING IRR-13. COMMON TRENCH CONSTRUCTION IS PROHIBITED.
VERTICAL SEPARATION: THE PRESSURIZED RECYCLED WATER PIPING SHALL MAINTAIN A MINIMUM ONE FOOT VERTICAL SEPARATION AT ALL TIMES FROM ALL PRESSURIZED POTABLE WATER PIPING AND/OR A SANITARY SEWER SYSTEM. THE PRESSURIZED RECYCLED WATER PIPING SHALL BE INSTALLED ONE FOOT BELOW ALL PRESSURIZED POTABLE WATER PIPING AND ONE FOOT ABOVE ALL SANITARY SEWER SYSTEMS.
 IF A ONE FOOT VERTICAL SEPARATION IS NOT POSSIBLE, SPECIAL CONSTRUCTION REQUIREMENTS SHALL BE CONSIDERED, REFER TO DISTRICT STANDARD DETAIL DRAWING IRR-13.
7. QUICK COUPLING VALVES ON RECYCLED WATER IRRIGATION MAINLINE MAY BE REQUIRED TO BE REMOVED AT THE END OF THE MAINTENANCE PERIOD. IF THE QUICK COUPLING VALVES ARE REQUIRED TO BE REMOVED, THE DISTRICT SHALL DETERMINE THE MANNER OF REMOVAL.
8. ADJUST ALL SPRINKLER, IMPACT AND ROTOR HEADS AND DRIP SYSTEMS TO MINIMIZE DIRECT OVERSPRAY, WINDBLOWN SPRAY, PONDING AND RUNOFF, ONTO NON-IRRIGATED AREAS.
9. THE INSTALLATION OF INTERNAL, EXTERNAL, OR IN-LINE ANTI-DRAIN VALVES ARE MANDATORY TO PREVENT LOW-HEAD DRAINAGE IMMEDIATELY AFTER THE REMOTE CONTROL VALVE HAS CLOSED.
10. ANY DEVIATIONS FROM THE SIGNED AND APPROVED SET OF PLANS MUST BE APPROVED IN WRITING PRIOR TO INSTALLATION BY THE DESIGN CONSULTANT AND THE DISTRICT. ANY REVISION MUST BE SUBMITTED TO THE DESIGN CONSULTANT AND THE DISTRICT FOR APPROVAL. FAILURE TO COMPLY WILL RESULT IN A "STOP WORK NOTICE."
11. FINAL COVERAGE TESTS MUST BE PERFORMED AND PASSED BEFORE A FINAL RELEASE WILL BE ISSUED. DIRECT OVERSPRAY, WINDBLOWN SPRAY, PONDING, AND RUNOFF ONTO NON-IRRIGATED AREAS ARE TO BE MINIMIZED.
12. CROSS-CONNECTION TESTS SHALL BE PERFORMED ON ALL WATER SYSTEMS, INCLUDING EXISTING AND FUTURE RECYCLED WATER IRRIGATION SYSTEMS, AND ALL POTABLE AND NON-POTABLE WATER SYSTEMS, AS DETERMINED BY THE DISTRICT PRIOR TO THE USE OF RECYCLED WATER. ALL CROSS-CONNECTION TESTS MUST BE PERFORMED AND PASSED BEFORE A FINAL RELEASE WILL BE ISSUED.
13. THE ENTIRE IRRIGATION SYSTEM AND ITS APPURTENANCES, AS WELL AS ALL ONSITE FACILITIES AND APPURTENANCES SHALL BE INSPECTED AND REVIEWED BY THE DISTRICT. FINAL INSPECTIONS/SITE REVIEWS MUST BE PERFORMED AND PASSED BY THE DISTRICT BEFORE A FINAL RELEASE WILL BE ISSUED.
14. UNLESS DIRECTED OTHERWISE BY THE DISTRICT, RECYCLED WATER SYSTEM REGULAR HOURS OF OPERATION ARE AS FOLLOWS:
 - TURF AREAS AND CENTER STREET MEDIANS - BETWEEN 6:00 P.M. AND 6:00 A.M.
 - SLOPES AND GROUNDCOVER/SHRUB AREAS - ANY HOUR
 - GOLF COURSES - FILL IMPOUNDMENTS BETWEEN 4:00 A.M. AND 6:00 P.M.
 THE CONSIDERATION FOR POTENTIAL PUBLIC CONTACT WITH RECYCLED WATER SHALL TAKE PRECEDENCE OVER ALL RECYCLED WATERING SCHEDULES. ALL IRRIGATION SYSTEMS RUN TIMES SHALL BE ADJUSTED TO MINIMIZE CONTACT WITH RECYCLED WATER ON AN INDIVIDUAL LATERAL SYSTEM BASIS. THE DISTRICT MAY REQUIRE SPECIFIC RUN TIMES AND DURATIONS WHERE THERE IS A HISTORY OF PUBLIC CONTACT.
15. THE FOLLOWING INFORMATION MUST BE SUBMITTED TO THE DISTRICT AT THE COMPLETION OF THE PROJECT BEFORE A FINAL RELEASE WILL BE ISSUED:
 - a. ONE SET OF "AS-BUILT" BOND DRAWINGS WHICH REFLECT THE CONTRACTORS REDLINE MARK-UPS.
 - b. ONE COPY OF CONTRACTORS REDLINE MARK-UPS ON THE ORIGINAL APPROVED DRAWINGS.
 - c. THESE PLANS NEED TO SPECIFY "RECORD DRAWINGS" ON EACH SHEET WITH A COVER SHEET THAT INCLUDES ALL SIGNATURES AT THE TIME OF APPROVAL FOR CONSTRUCTION.
 - d. FOLLOWING REVIEW AND APPROVAL OF "AS-BUILT" DRAWINGS, FINAL DRAWINGS CAN BE USED TO GENERATE COLOR CHARTS FOR SUBMITTAL TO THE DISTRICT.
 - e. UPON APPROVAL OF COLOR CHARTS THE FOLLOWING IS NEEDED FOR FINAL SUBMITTAL.
 - f. ONE SET - COLOR CHARTS, 11" X 17" LAMINATED HARD COPY - ONE SET PER CONTROLLER.
 - g. ONE SET - IRRIGATION SITE PLANS AND COLOR CHARTS IN ELECTRONIC FORMAT (AUTOCAD, PDF, OR OTHER)
 - h. A COMPLETED DISTRICT BACKFLOW INVESTIGATION AND TEST REPORTS FOR ALL BACKFLOW PREVENTION ASSEMBLIES ON SITE. SUBMIT TO THE DISTRICT.
 - i. CERTIFICATES OF SUBSTANTIAL COMPLIANCE, CALIBRATION, ACCEPTANCE AND/OR PROPER INSTALLATION/OPERATION OF THE IRRIGATION SYSTEM AND APPURTENANCES AS DEEMED NECESSARY BY THE DISTRICT.
 - j. A COMPLETED DISTRICT RECYCLED WATER USE PERMIT (APPENDIX 6) FOR EACH RECYCLED WATER POINT OF CONNECTION.
16. FAILURE TO COMPLY WITH ANY OF THE PRIOR PROVISIONS AND/OR ANY OTHER OF THE RULES AND REGULATIONS WILL PLACE THE SYSTEM IN VIOLATION OF THE RULES AND REGULATIONS AND WILL RESULT IN A STOP WORK NOTICE AND/OR TERMINATION OF SERVICE UNTIL APPROPRIATE CORRECTIVE STEPS HAVE BEEN TAKEN.

ADDITIONAL NOTES MAY BE ADDED, AS APPROPRIATE.

PLACE MWND STANDARD NOTES ON IRRIGATION PLANS

MOULTON NIGUEL WATER DISTRICT
 RECYCLED WATER STANDARD NOTES

IRR-47

RECORD DRAWING

THIS RECORD DRAWING IS FOR THE FACILITIES REFERENCED IN THE TITLE BLOCK ONLY AND HAS BEEN PREPARED IN PART FROM INFORMATION COMPILED BY AND FURNISHED BY OTHERS. THE INFORMATION IS FOR REFERENCE ONLY, AND IS NOT A GUARANTEE OF ACTUAL FIELD CONDITIONS OR DEPICTED INFORMATION. THE DISTRICT IS NOT RESPONSIBLE FOR ERRORS OR OMISSIONS INCORPORATED INTO THESE DRAWINGS. IF THE PRECISE LOCATION OF ANY FACILITY IS REQUIRED, THE FACILITY SHOULD BE FIELD LOCATED IN THE PRESENCE OF A DISTRICT INSPECTOR/ENGINEER.

PLACE THE RECORD DRAWING DISCLAIMER AS CONSISTENTLY AS POSSIBLE IN THE SAME SPACE ON ALL IRRIGATION SHEETS

WATER METER STATISTICS

METER NUMBER	
TRACT AND LOT NUMBERS	
USE AND SITE NUMBER	
METER SIZE	
ELEVATION	
ZONE/HGL	
POC STATIC PRESSURE	PSI
REQUIRED DYNAMIC PRESSURE	PSI
AVERAGE APPLICATION RATE	GPM / ACRE
MAXIMUM APPLICATION RATE	GPM / ACRE
AREA SERVED	ACRES
ANNUAL WATER USE	ACRE FEET

PLACE RECYCLED/POTABLE WATER CRITERIA BLOCK AS CLOSE AS POSSIBLE TO THE POINT OF CONNECTION SHOWN ON PLANS

MOULTON NIGUEL WATER DISTRICT
FOR POTABLE WATER IRRIGATION ONLY

This set of irrigation plans has been reviewed and approved by Moulton Niguel Water District for adherence to District Rules and Regulations for Potable Water irrigation only. District is not responsible for design assumptions and accuracy. District is not guaranteeing availability of water to this area.

REVIEWED BY _____ DATE _____

PLACE POTABLE WATER IRRIGATION SIGNATURE BLOCK IN LOWER RIGHT HAND CORNER OF ALL IRRIGATION SHEETS

MOULTON NIGUEL WATER DISTRICT USE SITE NUMBER(S) _____

This set of irrigation plans has been reviewed and approved by Moulton Niguel Water District for adherence to District Rules and Regulations for Recycled Water irrigation only. District is not responsible for design assumptions and accuracy. District is not guaranteeing availability of water to this area. Moulton Niguel Water District's approval does not relieve applicant from adhering to any health department requirements.

REVIEWED BY _____ DATE _____

PLACE RECYCLED WATER IRRIGATION SIGNATURE BLOCK IN LOWER RIGHT HAND CORNER OF ALL IRRIGATION SHEETS

MOULTON NIGUEL WATER DISTRICT

REVISION DATE: _____ APPROVED BY: _____ DATE: _____

The delta revision(s) shown above has (have) been reviewed and approved by Moulton Niguel Water District for adherence to District Rules and Regulations for Potable Water used for Irrigation only. District is not responsible for design assumptions and accuracy. District is not guaranteeing availability of water to this area.

PLACE POTABLE WATER IRRIGATION REVISION BLOCK NEXT TO MNWD SIGNATURE BLOCK

MOULTON NIGUEL WATER DISTRICT

REVISION DATE: _____ APPROVED BY: _____ DATE: _____

The delta revision(s) shown above has (have) been reviewed and approved by Moulton Niguel Water District for adherence to District Rules and Regulations for Recycled Water Irrigation only. District is not responsible for design assumptions and accuracy. District is not guaranteeing availability of water to this area.

PLACE RECYCLED WATER IRRIGATION REVISION BLOCK NEXT TO MNWD SIGNATURE BLOCK

MOULTON NIGUEL WATER DISTRICT

PLAN SHEET BLOCKS

IRR-48

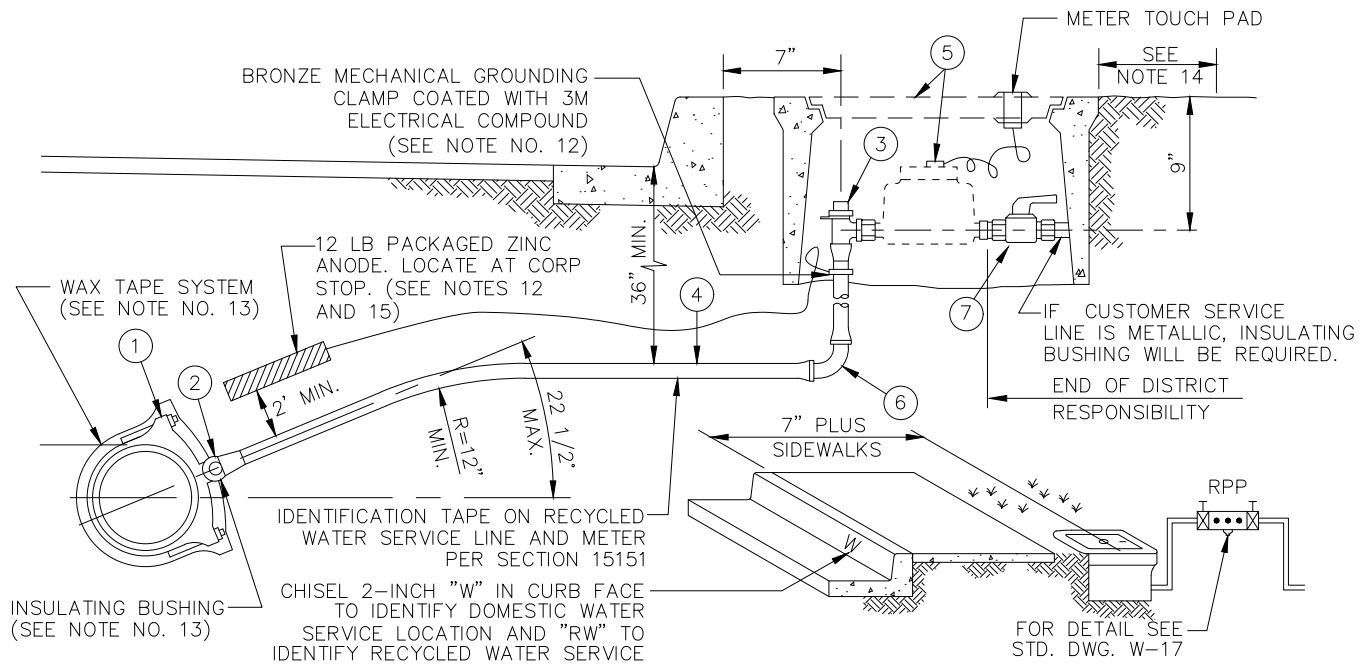

MATERIAL LIST		
ITEM	DESCRIPTION	COMMENTS
①	SERVICE SADDLE WITH I.P. THREAD	BRONZE
②	CORPORATION STOP (BALL TYPE)	I.P. THREAD X FLARE
③	ANGLE STOP	FLARE GROUND ANGLE METER STOP
④	1 1/2" OR 2" COPPER TUBING	TYPE "K" SOFT
⑤	CUSTOMER METER, METER BOX, AND LID	PURCHASED FROM DISTRICT SET BY CONTRACTOR
⑥	90°	COPPER SWEAT FITTING
⑦	CUSTOMER VALVE	PURCHASED FROM DISTRICT SET BY CONTRACTOR. METER FLANGE X F.I.P.

NOTES

- THE CORPORATION STOP TAP WILL BE MADE AS RECOMMENDED BY THE MANUFACTURER. ALL DRY TAPS WILL BE MADE BY MACHINE WITH GUIDE OR PILOT TAP.
- THE WATER SERVICE SHALL EXTEND PERPENDICULAR TO THE CENTERLINE OF THE STREET FROM THE WATER MAIN.
- METER TO BE CENTERED INSIDE THE METER BOX.
- WHEEL STOPS REQUIRED TO PREVENT VEHICLES FROM BLOCKING ACCESS TO WATER METERS.
- WHEN BACKFLOWS ARE REQUIRED, LOCATION WILL BE DETERMINED AT DISTRICT DISCRETION. GENERALLY BACKFLOW IS INSTALLED ADJACENT TO WATER METER.
- ALL 1 1/2" AND 2" SERVICES WILL BE LOCKED "OFF" AFTER NEW MAIN IS TIED IN.
- NO TAP TO MAIN SHALL BE WITHIN 18" OF A JOINT, FITTING OR ANOTHER TAP.
- SERVICE SHALL BE BACKFILLED WITH SAND, MIN. (SE 30) 6" BELOW AND ABOVE SERVICE.
- METER SIZE SHALL BE THE SAME AS THE SERVICE LINE.
- ALL COPPER FITTINGS SHALL BE SILVER SOLDER.
- ALL SERVICE LINES SHALL BE POLYETHYLENE SLEEVED.
- WATER SERVICES SHALL BE PROVIDED WITH A ZINC ANODE SYSTEM TO PROTECT FROM CORROSION.
- WATER SERVICES SHALL BE ISOLATED FROM STEEL AND DIP PIPELINES. PROVIDE A NYLON INSULATING BUSHING BETWEEN THE SERVICE SADDLE AND THE CORPORATION STOP. THE OUTLET SIZE ON THE SERVICE SADDLE SHALL BE INCREASED 1/2-INCH TO ACCOMMODATE THE BUSHING. WAX TAPE ON BRONZE OR STAINLESS STEEL SADDLE PER SECTION 13110. INSULATING BUSHING AND WAX TAPE REQUIRED FOR STEEL AND DIP MAINS ONLY.
- BOX SHALL BE LOCATED SO THAT MIN. 12" CLEARANCE IS MAINTAINED FROM ADJACENT OBSTRUCTIONS ON ALL SIDES.
- LOCATE ANODE AT EITHER THE CORP STOP OR ANGLE STOP PER INSPECTOR'S DIRECTION.

MOULTON NIGUEL WATER DISTRICT
STANDARD 1-1/2" & 2" WATER SERVICE

W-3
AUGUST 2024