



moulton niguel water district

STANDARD SPECIFICATIONS

**FOR CONSTRUCTION OF POTABLE WATER,
RECYCLED WATER, AND WASTEWATER FACILITIES**

**STANDARD
SPECIFICATIONS
FOR
THE CONSTRUCTION OF
POTABLE WATER, RECYCLED WATER,
AND WASTEWATER FACILITIES**

Approved by:

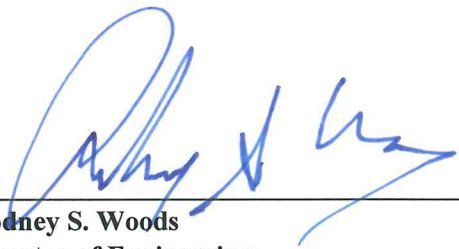

**Rodney S. Woods
Director of Engineering
RCE 63130**

January 2019

MOULTON NIGUEL WATER DISTRICT

**26161 Gordon Road
Laguna Hills, CA 92653
(949) 831-2500**

MOULTON NIGUEL WATER DISTRICT
STANDARD SPECIFICATIONS FOR THE CONSTRUCTION OF
POTABLE WATER, RECYCLED WATER,
AND WASTEWATER FACILITIES

TABLE OF CONTENTS

Section Title

Design Criteria, Potable Water Facilities

Design Criteria, Off-Site Recycled Water Facilities

Design Criteria, Wastewater Facilities

Standard Technical Specifications

Standard Drawings

Approved Materials List

POTABLE WATER FACILITIES DESIGN CRITERIA

1.01 WATER MAIN DESIGN

A. Minimum Size Mains

1. The normal minimum size distribution main shall be 8-inch, unless otherwise accepted by the District.

B. Design Flow and Pipe Velocity Criteria

1. Velocity Criteria: The criteria for velocity shall be as described herein. The maximum velocity in a line shall not exceed 7 fps (feet per second) during the peak hour condition. The peak hour is defined as 3 times the average day demand. The maximum velocity in a line shall not exceed 10 fps during the maximum day plus fire demand condition. The maximum day is defined as 2 times the average day demand.
2. Fire Flow Demand: The design criteria to be used for determining fire flow requirements shall be the actual fire flow requirements as determined by the Orange County Fire Authority and the “Fire Master Plans for Commercial & Residential Development”; latest revision. Before designing the potable water system for a project, the Applicant shall complete the Orange County Fire Marshal's water availability form for the project and submit to the District. Indication of the Fire Marshal's approval is required to be on the improvement plans prior to the District's acceptance. All fireflow tests shall be performed by the District using the District's hydraulic model. The District shall charge a fee to perform this fireflow test.

C. Type of Water Main Pipe

1. 8-inch and 12-inch diameter pipes: C900 PVC pipe, DR-14. Where ductile-iron pipe is required by the District, provide Class 350 pipe.
2. 16-inch through 20-inch diameter pipes: C900 PVC pipe, ductile-iron pipe, or CML&C steel pipe
3. 24, 30 and 36-inch diameter pipes: CML&C steel pipe
4. Non-buried piping shall be metallic.
5. Class of pipe shall be in accordance with pressure requirements provided by the District.

D. Minimum Depth to Top of Water Main Pipe

1. Distribution Mains (12-inch diameter and smaller): The top of the pipe is to be a minimum of 42 inches below finished grade.
2. Transmission Mains (Larger than 12-inch diameter): The top of the pipe is to be a minimum of 48 inches below finished grade.

1.02 WATER LAYOUT DESIGN

A. Standard Location

1. Potable water main center-lines shall normally be located 6 feet from the curb face and may be deflected to avoid cross gutters, concrete bus lanes, or other interferences. Deflection shall be limited to 50-percent of manufacturer's recommended deflection for AWWA compliant pipe products. Note that some manufacturers do not allow deflection at joints for PVC.

B. Isolation Valves

1. Type:
 - a. Butterfly valves shall only be used on lines 16-inch diameter and larger or as specifically shown on the plans.
 - b. Resilient wedge gate valves shall be used on lines 4-inch through 12-inch diameter.
2. Fittings: Generally the District requires all fittings and valves to have "push-on" type ends, except at tees and crosses where valves are required. Valve and fitting are to be joined by a flange.
3. Spacing
 - a. As a general rule, there should be three (3) valves where one main ties into another. Where two mains cross, there shall be four (4) valves. On long blocks, intermediate valves should be installed so that only a maximum of 20 lots or 600 feet, whichever is less, would have to be shut off at any one time.
 - b. Valves should also be spaced so that not more than two fire hydrants should be out of service at any one time.
 - c. In most cases where water mains pass through easements outside traveled streets, a valve shall be located at each end of the easement.
 - d. The final determination of valves and locations shall be per the District.

C. Automatic Control Valves

1. Automatic control valves shall be installed above ground or within a vault to provide for adjustment, maintenance and repair. Direct burial of a control valve will not be permitted under any circumstance.
2. Automatic control valves are to be installed with ductile iron piping or cement-mortar lined and coated steel pipes.

D. Fire Hydrant Locations

1. The location of fire hydrants shall be as determined by the Orange County Fire Marshal, and per the guidelines set herein. The exact location with respect to the curb and sidewalk shall be as shown in District Standard Drawing W-7.
 - a. Fire Hydrant spacing
 - 1) The maximum fire hydrant separation shall be 300 feet from fire hydrant to fire hydrant. The only exceptions will be at the discretion of the Fire Marshal.
 - 2) Fire hydrants shall be located near the beginning of curb return (BCR) or lot lines.

- 3) No fire hydrant shall be located within 3 feet of a driveway, or closer than 40 feet to any structure, unless approved by the Fire Marshal.
 - 4) In situations where the fire hydrant run is over 100 feet or where the Orange County Fire Authority flow rate requirements exceed 1,500 gpm for any hydrant, the size of the lateral for that hydrant shall be 8-inch diameter. In situations where the residual pressure is low, the District may require larger diameter hydrant laterals.
- b. Types of Hydrants
 - 1) Wet barrel all- bronze type hydrants, as specified by the District, are to be used except in hill areas or special "high-risk" situations where the District may require a wet barrel with check valve.
 - c. Plan Requirements
 - 1) Fire hydrants shall be shown on the plans where the hydrant is to be located with respect to the property line, and easements that will be provided. The building foot prints or building pad areas are also to be shown.
- E. Blow-Offs
1. Fire hydrant assemblies shall be installed at ends and at low points on mains 12-inch diameter and smaller.
 2. On mains 16-inch diameter and larger, use of blow-offs versus fire hydrants at ends and low points will be as directed by the District.
 - a. Blow-offs shall be installed in a level section of pipe.
 - b. Blow-offs shall not be connected to any sewer, submerged in any stream, or installed in any manner that will permit back siphoning into the distribution system.
 3. Temporary blow-offs shall be installed as service stub-outs for testing and flushing purposes.
- F. Air Valves
1. Air and vacuum valves are to be installed at all high points in the line, per requirements of AWWA M51, and as directed by the District. Air and vacuum valves shall be installed in above ground enclosures accepted by the District.
 - a. Air-Release Valve Criteria: Size per AWWA M51 to release 2-percent of the flowrate of water passing through the system in terms of air at standard conditions.
 - b. Air/Vacuum Valve Criteria: Size per AWWA M51 to accommodate filling and draining of pipeline.
- G. Separation of Potable Water from Sewer and Recycled Water Lines
1. The State Water Resources Control Board (SWRCB) and State of California regulations (Title 22, Chapter 16 Section 64572) shall be followed when designing and constructing new potable water, recycled water, and sewer mains. When SWRCB and District standards conflict, the most stringent requirement shall apply unless otherwise accepted by the District.

- a. Horizontal Separation
 - 1) The Regional Water Quality Control Board regulations require a 10-foot minimum separation between potable water and sewer mains. However, in special situations where there is no alternative but to install the mains with less than the required separation, special construction will be considered on an individual basis by the District for acceptance.
 - 2) Minimum separation of potable water service line and a storm drain or recycled water line shall be 4 feet.
 - 3) Minimum separation of potable water service line and sewer lateral shall be 5 feet.
 - 4) Potable water lines are normally located on the opposite side of the street from the recycled water line.
- b. Vertical Separation
 - 1) Normally, potable water, recycled water, and sewer mains shall be located vertically from the street surface in order of the higher quality, i.e., potable water shall be above recycled water and recycled water shall be above sewer.
 - 2) Whenever a crossing must occur where a sewer or recycled water main crosses within 1 foot below a potable water main, special construction will be required and accepted on an individual basis by the District.
 - 3) These construction requirements shall not apply to house laterals that cross perpendicular less than 1 foot below a pressure water main.

H. Trenchless Construction

- 1. Tunneling will not be permitted.
- 2. The use of a jack and bore or hydraulic ram may be employed if accepted by the District.

1.03 WATER SERVICE DESIGN

A. Minimum Potable Service Size

- 1. Minimum potable service line size shall be 3/4-inch diameter with a 3/4-inch meter. The sizing of the service shall be specified on the plans designated by lot numbers. Services for commercial or industrial developments are to be as shown on plans or as directed by the District.
- 2. Minimum potable service line size shall be 1-inch diameter if serving a sprinkler system.
- 3. Meters shall be the same size as the service line, except where the meter size is 3-inch. Where this occurs, the pipe is to be 4-inch diameter reduced to 3-inch diameter at the meter. Reducers shall be located inside the meter vault.

B. Type of Service Line

- 1. Acceptable service line material is as described below:
 - a. 3/4-inch through 2-inch diameter service line shall be copper tubing.
 - b. 4-inch diameter and larger shall be DIP per Section 15056, or PVC per Section 15064, as determined by the District (3-inch size not District Standard - use 4-inch piping up to meter).

C. Meters

1. Sizing:
 - a. All meters shall be appropriately sized by the Applicant in accordance with the California Plumbing Code.
 - b. Evidence of sizing shall be submitted to the District for review and acceptance prior to installation.
2. Bypass line:
 - a. A bypass line shall be installed on all commercial meter assemblies 3-inch and larger. A bypass line is not required on irrigation services, or as determined by the District.
 - b. A bypass line may be required on smaller installations which require continuous service.
3. Special cases meter types: For special cases where meters are needed for non-customer applications, such as for pump stations, use propeller meters and magnetic flowmeters listed in the specifications as directed by the District.

D. Pressure Regulating Valves

1. Individual pressure regulators shall be installed and set per California Plumbing Code or appropriate governing agency's standards.

E. Backflow Preventers

1. Application
 - a. A backflow prevention device shall be installed at all locations where the potential for a backflow condition into the District's potable water mains exists. The device shall be located immediately downstream the meter assembly.
 - b. The type of device required will depend on the level of potential hazard which exists. The District will make the final determination of what type of backflow device is required.
 - c. Any service providing potable water to anything other than a private residential dwelling shall have backflow protection.
 - d. An above ground double check detector assembly is required on a private on-site fire protection system connected to the District's potable water mains.
2. Responsibility
 - a. The District will maintain only the upstream mainline shut-off valve and service to the point of connection of the assembly and the bypass meter. The owner is responsible for the testing, maintenance, and repair or replacement of the device.

1.04 RESTORATION AND CLEANUP

- A. The Contractor shall restore or replace all removed, damaged, or otherwise disturbed existing surfaces or structures not otherwise noted on the plans or specified herein to a condition equal to that before the work began and to the satisfaction of the District, City, or other agency having jurisdiction. All excess earth and all other debris shall be removed and disposed of by the Contractor and the entire site of the work shall be left in a condition acceptable to the District prior to final acceptance of the work. All restoration and cleanup shall be performed in accordance with the District's Standard Specifications.

1.05 STANDARD WATER NOTES

- A. Include all General Construction Notes and General Potable Water Notes, as listed in the Standard Drawings, on all facility improvement plans or potable water system construction plans.

END OF SECTION

OFF-SITE RECYCLED WATER FACILITIES DESIGN CRITERIA

1.01 GENERAL

- A. Design of all off-site recycled water facilities shall be as set forth under the Rules and Regulations for Users of Recycled Water, and "Potable Water Facilities Design Criteria," herein, except as modified or expanded upon in the following sections.

1.02 RECYCLED WATER LAYOUT DESIGN

A. Location

- 1. Recycled water mains shall be located 6 feet from curb face on the opposite side of the street of the potable water mains and shall meet all separation requirements stated herein.
- 2. Recycled water mains shall have a minimum of 48 inches cover to the roadway surface.

B. Valves:

- 1. Spacing: On long blocks, intermediate valves shall be provided upon request of the District.

C. Separation of Recycled Water from Sewer and Potable Water Lines

- 1. The State Water Resources Control Board (SWRCB) and State of California regulations (Title 22, Chapter 16 Section 64572) shall be followed when designing and constructing new potable water, recycled water, and sewer mains. When SWRCB and District standards conflict, the most stringent requirement shall apply unless otherwise accepted by the District.

a. Horizontal Separation

- 1) The Regional Water Quality Control Board regulations require a 10-foot minimum separation between recycled water and sewer water mains. However, in special situations where there is no alternative but to install the mains with less than the required separation, special construction will be required and accepted on an individual basis by the District.
- 2) Minimum separation of potable water service line and a recycled water line shall be 4 feet.
- 3) Minimum separation of recycled water service line and sewer lateral shall be 5 feet.
- 4) Recycled water lines are normally located on the opposite side of the street from the sewer or potable water line.

b. Vertical Separation

- 1) Normally, potable water, recycled water, and sewer mains shall be located vertically from the street surface in order of the higher quality, i.e., potable water shall be above recycled water and recycled water shall be above sewer.
- 2) Whenever a crossing must occur where a recycled water main crosses within 1 foot below a sewer or potable water main, special construction will be required and accepted on an individual basis by the District.

- 3) These construction requirements shall not apply to house laterals that cross perpendicular less than 1 foot below a pressure water main.

1.03 SPECIAL OFF-SITE RECYCLED WATER NOTES

- A. Include all General Construction Notes, General Potable Water Notes, and General Off-Site Recycled Water Notes, as listed in the Standard Drawings, on all recycled water system construction plans.

END OF SECTION

WASTEWATER FACILITIES DESIGN CRITERIA

1.01 SEWER PIPE DESIGN

A. Peak Flows

1. Design peak wet weather flows in pipelines 12 inches in diameter and smaller are to be limited to approximately $d/D = 0.5$, where d = depth of flow and D = diameter of pipe. Pipes over 12 inches are to be limited to approximately $d/D = 0.75$.

B. Generation Rates

1. Sewerage generation rates for various developments within the District shall be as established by the District.

Item	Recommendation
Peaking Factors	
Peak Dry Weather Flow	$Q_p = 1.84(Q_{avg})^{0.92}$; cfs
Unit Generation Rates	
Single-Family Residential	300 gpd/DU
Multi-Family Residential	240 gpd/DU
Schools	800 gpd/ac
Commercial/Office	1,500 gpd/ac
Industrial	1,500 gpd/ac
Parks	250 gpd/ac
Hospital	3,750 gpd/ac
Hotel	80 gpd/room

C. Piping Schedule

1. Unless noted otherwise on the plans or in the specifications, pipe shall be furnished in accordance with the following materials schedule.
 - a. Sewer mains shall be the following when less than or equal to 15-inch diameter and between 4 and 15-feet depths:
 - 1) Polyvinyl Chloride (PVC) Pipe ASTM D3034 SDR-35
 - 2) Vitrified Clay Pipe (VCP) ASTM C700
 - b. Engineering calculations submitted to the District for acceptance are required for the following piping situations:
 - 1) All pipe 18-inch diameter and larger
 - 2) All pipe with depth (measured from invert elevation) greater than 15-feet, or less than 4-feet
 - c. The District may allow the use of the following pipe by special permission only:
 - 1) High Density Polyethylene (HDPE) ASTM F714
 - 2) PVC ASTM D3034 SDR-26
 - 3) PVC ASTM F679

D. Minimum Size

1. The District will not accept any sewerline smaller than 8 inches nor any sewerline that is within a common trench (two or more utilities in the same trench).

E. Minimum and Maximum Slope Design

1. Slopes

- a. All sewers shall be so designed and constructed to give mean velocities, when flowing half full, of not less than 2.0 fps, based on Manning’s Formula using an “n” value of 0.013. The following are minimum slopes; however, slopes greater than these are desirable:

<u>Sewer Size (inches)</u>	<u>Minimum Slope in Feet</u>
8	0.004
10	0.0032
12	0.0028
15	0.0022

- b. Maximum slopes shall be 15% unless authorized by the District.
- c. Inverted siphons will only be allowed at locations accepted by the District.

F. High Velocity Protection

1. Where flow velocities greater than 10 fps are attained, special provisions shall be made to protect against displacement by erosion and shock for pipe entering a manhole and for concrete manhole base and flow channels.

G. Minimum Cover

1. Minimum cover from finish street grade to top of sewer main pipe is to be 7 feet, unless otherwise accepted by the District.

1.02 SEWER LAYOUT DESIGN

- A. Location: Wherever possible, in local residential and industrial streets, pipe is to be located 5 feet off the street centerline. In major, primary, and secondary highways, pipe will be located in the center of the driving lane nearest to the center of the street. Pipe will not be located in median strips or parking lanes. Sewer pipe shall generally be laid in straight runs from manhole to manhole. Sewer pipe shall not be installed using horizontal or vertical curves, unless special permission is obtained from the District.

1. Alignment

- a. Barring other limiting design and construction considerations, a maximum separation between sewer and potable water mains in new subdivisions shall be achieved by the following construction procedures:
 - 1) Sewer mains should be installed on the opposite side of the street centerline from the potable water mains.

MOULTON NIGUEL WATER DISTRICT

- 2) If horizontal curves are accepted by the District on curvilinear streets, the sewers shall parallel as nearly as possible the street centerline.
- B. Radius of Curvature: Joint deflections shall be a maximum of 50% of the manufacturer's recommended value for the size and material of pipe to be used.
- C. Stationing Procedure: Sewer centerline stationing shall be shown (example: 0+00) and be independent of street stationing with the stationing starting at the most downstream manhole or connection to existing sewer. All manholes are to be numbered (example MH no. 1).
- D. Manhole Spacing and Location: Manholes shall be installed at the end of each line; at all changes in grade, size, or alignment; at all intersections; and at distances not greater than 400 feet for 8- through 15-inch sewers and 500 feet for 18- to 30-inch sewers.
- E. Separation of Sewer from Potable Water and Recycled Water Lines
1. The State Water Resources Control Board (SWRCB) and State of California regulations (Title 22, Chapter 16 Section 64572) shall be followed when designing and constructing new potable water, recycled water, and sewer mains. When SWRCB and District standards conflict, the most stringent requirement shall apply unless otherwise accepted by the District.
 - a. Horizontal Separation
 - 1) The Regional Water Quality Control Board regulations require a 10-foot-minimum separation between potable water and sewer mains. However, in special situations where there is no alternative but to install the mains with less than the required separation, special construction will be required and accepted on an individual basis by the District.
 - 2) Minimum separation of potable water service line and sewer lateral shall be 5 feet.
 - 3) Sewer lines are normally located on the opposite side of the street from the potable water or recycled water line.
 - b. Vertical Separation
 - 1) Normally, potable water, recycled water, and sewer mains shall be located vertically from the street surface in order of the higher quality, i.e., potable water shall be above recycled water and recycled water shall be above sewer.
 - 2) Whenever a crossing must occur where a sewer main crosses above a potable water or recycled water main or within 1-foot below a potable water or recycled water main, special construction will be will be required and accepted on an individual basis by the District.
 - 3) These construction requirements shall not apply to house laterals that cross perpendicular less than 1 foot below a pressure water main.
- F. Trenchless Construction
1. Tunneling will not be permitted.
 2. The use of a jack and bore or hydraulic ram may be employed if accepted by the District.

1.03 MANHOLES

A. Manhole Depth and Size

1. Manhole depth is calculated from finish grade to lowest pipe invert. Minimum manhole depth is to be 8 feet. The standards for the District sewers call for a depth criteria of about 8 feet to 12 feet for manholes. However, if larger-depth manholes are required and accepted by the District, the following criteria will govern. Manholes shall be pre-cast reinforced concrete with eccentric cone style. The minimum diameter of manholes shall be as follows:

<u>Depth, feet</u>	<u>Manhole Diameter, in</u>
<12	48
≥12	60

2. Depth of manhole shall be measured from the pipe invert to the finished surface of the street with a tolerance of ± 6 inches.
3. For larger sized sewer mains or special circumstances, the manhole size will be as shown on plans.

B. Allowable Elevation Change through Manholes

1. Allowable elevation change through manholes shall be as follows:
 - a. Straight run through manholes based on 0.10 foot loss
 - b. Right angle turn in manholes based on 0.5 velocity head loss or 0.20 foot, whichever is greater

C. Manhole Covers

1. Provide cast-iron manhole frame and covers for manholes installed in paved areas.
2. For non-paved areas with no vehicular or pedestrian access, or any elevated manholes, provide composite frame and covers.

D. Position of Covers

1. In new street developments, the manhole top shall be left at least 6 inches below subgrade. A heavy metal top with cleats the size of the manhole opening shall be mortared tight to the top. Specially cut plywood shall be placed in the bottom of the manhole before the temporary cover is installed. At the completion of final paving, the manholes shall be raised to final grade by using the necessary sized grade rings and plywood shall be removed prior to occupancy.

E. Access To Manhole

1. All sewer manholes shall be designed and constructed with direct access to them, in the form of pavement, turf block, or as otherwise accepted by the District.

F. Drop Manholes

1. Internal drop manholes are not permitted

2. External drop manholes are allowed only at the District's discretion.

G. Cleanouts: Cleanouts are not permitted. All sewer mains shall terminate at a manhole.

1.04 HOUSE LATERALS

A. All sewer laterals shall be located by the Applicant and shown (with stationing) on the improvement plans.

B. House connections shall be constructed to the property line. There shall be one house sewer lateral constructed for each individually owned dwelling unit and it shall have a minimum diameter of 4 inches.

C. Sewer laterals shall not be connected at manholes.

D. No wye for sewer house connection branch shall be placed closer than 5 feet downstream of the centerline of any structure.

E. Laterals shall be installed after mass grading is finished and before other utilities are installed.

F. The Contractor shall certify the elevation of the house lateral and connection point.

G. The technical specifications for sewer laterals shall be the minimum set of requirements that a customer shall meet in order to connect to the MNWD sewer system.

H. The District shall be notified in advance of, and be present to inspect, all work on wyes and laterals in the vicinity of sewer mains.

I. Sewer laterals shall be the sole ownership and responsibility of the customer, up to and including the connecting wye, but excluding the main pipe barrel portion of the wye fitting.

J. 4-inch sewer house connections shall be laid to the grade as established by the Applicant so that the 4-inch house connection will have a minimum cover of 6 feet from the top of the curb to the top of the pipe.

K. Townhouses and Condominium Laterals

1. For buildings containing two to four units, either one 4-inch diameter lateral to each unit or one 6-inch diameter or larger lateral to the building shall be used.

2. For buildings containing more than four units, either one 4-inch diameter lateral to each unit or one 8-inch diameter or larger lateral to the building shall be used.

3. A lateral shall serve only one building regardless of number of units per building.

1.05 PRETREATMENT

A. Industrial Treatment

1. Requirements for industrial pretreatment will be determined as a result of processing the Industrial Waste Questionnaire in Section 300.2.3.4 through the South Orange County Wastewater Authority (SOCWA) office. Design requirements will be dependent upon those industrial pretreatment requirements.

B. Grease Interceptors

1. Any food service establishment within the District shall be evaluated for the requirement to install grease interceptors, per District's Sewer System Management Plan, to protect the collections systems and treatment plants from fats, oils, and grease.
2. Determine size/volume of grease interceptors tanks per requirements of Uniform Plumbing Code. Indicate size/volume on plans.
3. Grease interceptors are to be installed on the sewer laterals from all restaurants and other commercial sewer connections as designated by the District.
4. The technical specifications for grease interceptors shall be the minimum set of requirements that a customer shall meet in order to connect to the District's sewer system.
5. Grease interceptors are the sole ownership and responsibility of the customer.
6. The grease interceptor shall be located on private commercial sewer laterals upstream of the connection to the District's sewer main.
7. The interceptor shall be located where it is easily accessible for inspection, cleaning, and removal of intercepted grease.
8. It will be the responsibility of the owner of each facility to maintain proper operating order of the interceptor unit and to remove accumulated grease at suitable intervals to avoid excessive grease buildup or odors in the unit. The District will periodically inspect the interceptor. The Applicant shall follow guidelines as provided by District staff.

C. Clarifiers / Sand Interceptors

1. Clarifiers, sand interceptors, and/or hydrocarbon inlet filters shall be installed in areas which will produce petroleum products (e.g. mechanic shops, parking structures, car washes) at the direction of the District.
2. Installation of non-recirculating potable water systems is prohibited in commercial conveyor car wash and new commercial laundry systems.
3. Every sump or clarifier should be pumped out in full, cleaned, and checked for needed repairs at least annually. Any sump or clarifier should be pumped out in full and cleaned immediately if solids in any chamber exceed 25% of that chamber's capacity. All waste and repair manifests should be maintained for three years. If a sump or clarifier is overflowing, all flows to the sump or clarifier should be immediately pumped out in full, cleaned, and repaired before being placed back in service.

D. Trash Enclosures

1. Floor drains connected to sanitary sewer shall be protected from storm water entering the drains. Any drain in a trash enclosure or floor drain entering the sanitary sewer must have the following:
 - a. Filtered catch basin to capture any sediment, debris, trash, oil, and grease to prevent it from entering the sanitary sewer system
 - b. Roof to prevent storm water from entering the sanitary sewer system
 - c. Designed finished grades to divert sheeting water flow away from the drain

1.06 STANDARD SEWER NOTES

- A. Include all General Construction Notes and General Sewer Notes, as listed in the Standard Drawings, on all facility improvement plans or wastewater system construction plans.

END OF SECTION

**TABLE OF CONTENTS
TECHNICAL SPECIFICATIONS**

<u>Section</u>	<u>Description</u>
01025	Measurement and Payment
01045	Existing Facilities
01330	Submittal Procedures
01550	Bypass Pumping
01630	Product Substitution Procedures
01650	Product Delivery, Storage, and Handling Requirements
02200	Earthwork
02223	Trenching, Backfilling, and Compacting
03300	Concrete
03461	Precast Reinforced Concrete Manholes
03462	Precast Concrete Vaults
03463	Grease Interceptors
09810	Epoxy Coating for Sewer Manhole Rehabilitation
09900	Painting and Coating
13110	Dissimilar Metal Connections
13121	Corrosion Protection
15041	Chlorination of Potable Water Mains and Services for Disinfection
15042	Hydrostatic Testing of Pressure Pipelines
15043	Testing of Non-Pressure Pipelines and Manholes
15050	Hot Tap Connections
15056	Ductile-Iron Pipe and Fittings
15057	Copper, Brass, and Bronze Pipe Fittings and Appurtenances
15064	PVC Pressure Distribution Pipe
15066	Gravity Sewer Pipelines
15068	Sewer Laterals
15072	Disposal of Asbestos Cement Pipe
15089	Air Valves
15100	Manual Valves
15112	Backflow Preventers
15139	Fire Hydrants
15150	Meters
15151	Potable Water, Recycled Water, and Wastewater Facilities Identification
15162	Pipe Couplings and Adapters
15170	Wall and Slab Penetrations
15300	Automatic Control Valves

SECTION 01025

MEASUREMENT AND PAYMENT

PART 1 GENERAL

1.01 SUBMITTALS

- A. Schedule of Values

1.02 PAYMENT

- A. Payment for Unit Price Items

- 1. Payment for a unit price bid item shall be based upon the amount shown in the bid schedule multiplied by the total quantity measurement of the item and shall be full compensation for furnishing all supervision, planning, design, design engineering fees, labor, transportation, materials, equipment, tools and appurtenances required for construction of the item complete in place in accordance with the Plans and Specifications.

- B. Payment for Lump Sum Items

- 1. Payment for lump sum bid items shall be based upon the amount shown in the bid schedule and shall be full compensation for furnishing all supervision, planning, design, design engineering fees, labor, transportation, materials, equipment, tools and appurtenances required for construction of the unit of work complete in place in accordance with the Plans and Specifications.
- 2. Provide schedule of values for lump sum items as required by the District.

- C. Work Not Listed in the Bid Schedule

- 1. Costs for related work and appurtenances which are required and/or implied by the General Provisions, Technical Specifications, Special Provisions and Plans and are not listed as separate bid items, but are necessary to complete the project, shall be included in the appropriate bid item or items within the proposal.

1.03 MEASUREMENTS

- A. Measurement for unit price quantities shall be based upon the appropriate bid item in the proposal. The actual quantity of measurement shall be as constructed by the Contractor in place, in conformance with the Plans and Specifications.

- B. Linear Measurements: Measurement for pipelines and related facilities shall be made horizontally and/or vertically along the centerline of the pipeline and related facilities through tees, bends, valves, fittings and as shown on the Plans for its limits or as otherwise specified in the Special Provisions. Manholes and vaults shall be measured vertically from the lowest to the highest elevations and as shown on the Plans or as otherwise specified in the Special Provisions.

MOULTON NIGUEL WATER DISTRICT

- C. Area Measurements: Measurement for bid items involving area units shall be based upon the surface area measured in acres, square yards, square feet, or as indicated in the bid item.
- D. Volume Measurements: Measurement for bid items involving volume units shall be based upon the volume measured in cubic yards, tons, or as indicated in the bid item.
- E. Unit Measurements: Measurement for bid items involving units of the item shall be based upon the number of units counted as indicated in the bid item.
- F. Lump Sum Measurements: Measurement for a lump sum bid item shall be considered as a complete project or a portion of a project constituting a unit. The items to be included in the lump sum bid shall be as specified in the proposal bid item and/or the Standard or Special Provisions.

1.04 TESTING

- A. Party responsible for payment for testing is identified in individual sections under tests required. Where specifications are silent regarding responsible party paying for tests, costs of first tests will be paid by the District.
- B. If testing or inspection indicates failure of a material or procedure to meet Contract Document requirements, the District will backcharge the Contractor for retesting and re-inspection costs incurred by testing or inspection agency of the District's choice.
- C. Additional tests and inspections not specified herein, but requested by the District, will be paid for by the District, unless result of such tests and inspections are found to not comply with Contract Documents. In which case, the District will pay all costs for initial testing as well as retesting and re-inspection and backcharge the Contractor for retesting and re-inspection.
- D. Costs for additional tests or inspections required because of change in materials being provided, or change of source of supply, shall be paid by the Contractor direct to the testing laboratory.
- E. Cost of testing, which is required solely for convenience of the Contractor's scheduling and performance of Work, shall be borne by the Contractor.
- F. The Contractor shall pay all costs for correcting deficiencies.

PART 2 PRODUCTS (NOT USED)

PART 3 EXECUTION

3.01 SCOPE

- A. This section defines the bid items listed in the bid schedule and describes measurement and payment provisions for each of the bid items.
- B. Bid Item [#] – [To Be Determined by Engineer]

END OF SECTION

SECTION 01045

EXISTING FACILITIES

PART 1 GENERAL

1.01 SECTION INCLUDES

- A. Requirements for connection to, protection of, removal of, restoration of, and abandonment of existing District facilities

1.02 RELATED REQUIREMENTS

- A. Section 02223, Trenching, Backfilling, and Compacting
- B. Section 03300, Concrete
- C. Section 15041, Chlorination of Potable Water Mains and Services for Disinfection
- D. Section 15042, Hydrostatic Testing of Pressure Pipelines
- E. Section 15050, Hot Tap Connections
- F. Section 15072, Disposal of Asbestos Cement Pipe
- G. Section 15100, Manual Valves

1.03 CONDITION OF EXISTING FACILITIES

- A. The District cannot guarantee the condition, size, material, and location of existing facilities.
- B. Utilize a third party to provide a preconstruction video of existing facilities when determined necessary by the District.

1.04 LOCATION

- A. The Contractor shall be responsible for potholing and verifying in advance the locations of all existing pipelines as shown on the plans. Discrepancies shall be reported to the District prior to the fabrication of, or purchase of, material affected by the discrepancy. At a minimum, the Contractor shall pothole at all connections, crossings, and as otherwise directed by the District.

1.05 PROTECTION OF EXISTING UTILITIES AND FACILITIES

- A. The Contractor shall be responsible for the care and protection of all existing sewer pipe, water pipe, gas mains, culverts, power or communications lines, sidewalks, curbs, pavement, other hardscape, landscaping, or other facilities and structures that may be encountered in or near the area of the work.

- B. It shall be the duty of the Contractor to notify Underground Service Alert and each agency of jurisdiction and make arrangements for locating their facilities prior to beginning construction.
- C. In the event of damage to any existing facilities during the progress of the work and of the failure of the Contractor to exercise the proper precautions, the Contractor will pay for the cost of all repairs and protection to said facilities. The Contractor's work may be stopped by the District until repair operations are complete.

1.06 PROTECTION OF LANDSCAPING

- A. The Contractor shall be responsible for the protection of all the trees, shrubs, irrigation systems, fences, and other landscape items adjacent to or within the work area, unless they are directed to do otherwise on the plans.
- B. In the event of damage to landscape items, the Contractor shall replace the damaged items in a manner satisfactory to the District and the owner, or pay damages to the owner as directed by the District. The decision to replace or pay damages will be determined by the District and the owner of the damaged facilities.
- C. When the proposed pipeline is to be within planted or other improved areas in public or private easements, the Contractor shall restore such areas to the original condition after completion of the work. This restoration shall include grading, a placement of 5 inches of topsoil, resodding, and replacement of all approved landscape items that were present prior to construction. Native topsoil shall be used when feasible.
- D. If the Contractor does not proceed with the restoration after completion of the work or does not complete the restoration in a satisfactory manner, the District reserves the right to have the work done and to charge the Contractor for the actual cost of the restoration including all labor, material, and overhead required for restoration.

1.07 PERMITS

- A. All work shall conform to the specifications and requirements of the State of California Department of Transportation, the Orange County Public Works, the city having jurisdiction, or the other affected agencies involved. The Contractor shall keep a copy of all the required permits in the job site and comply with all the terms and conditions of said permits.

PART 2 PRODUCTS

2.01 GENERAL

- A. All materials used in making the connection or removing the facility from service shall conform to the applicable sections of these specifications.

2.02 GROUT

- A. Grout shall consist of Portland cement and water or of Portland cement, sand, and water; and all grout mixtures shall contain 2% of bentonite by weight of the cement. Grout shall be a pump mix with a minimum of 1-1/2 sacks cement (141 lbs) per cubic yard.

- B. Portland cement, water and sand shall conform to the applicable requirements of Section 03300, except that sand to be used shall be of such fineness that 100% will pass a standard 8-mesh sieve and at least 45%, by weight, will pass a standard 40-mesh sieve.

2.03 CONCRETE

- A. Concrete used for the replacement of damaged or removed facilities shall be in accordance with Section 03300 and shall match the mix design of the existing facility and per the requirement of the jurisdictional agency. If mix design of existing facility is unknown, assume Class B.

PART 3 EXECUTION

3.01 CONNECTION TO EXISTING FACILITIES

- A. All connections shall be made by the Contractor unless shown otherwise on the plans or specified herein.
- B. The Contractor shall notify the District a minimum of five working days before the time of any proposed shutdown of existing mains or services. The District may postpone or reschedule any shutdown operation if for any reason they feel that the Contractor is improperly prepared with competent personnel, equipment, or materials to proceed with the connection work.
- C. Connections shall be made only in the presence of the District, and no connection work shall proceed until the District has given notice to proceed. If progress is inadequate during the connection operations to complete the connection in the time specified, the District shall order necessary corrective measures. All costs for corrective measures shall be paid by the Contractor.
- D. The Contractor shall furnish all pipe and materials including furnishing all labor and equipment necessary to make the connections, all required excavation, backfill, pavement replacement, lights, and barricades, and may be required to include a water truck, high line hose, and fittings as part of this equipment for making the connections. The Contractor is advised that, due to the nature and condition of existing facilities, it is typically necessary for the District to make multiple attempts in order to isolate for making connections. The Contractor shall make the necessary arrangements to account for the time required for shutdown until work can proceed on affected facilities.
- E. The Contractor will de-water existing mains, as required, in the presence of the District. Any water generated from dewatering operations shall be discharged to the nearest sanitary sewer, unless otherwise directed by the District. If no sanitary sewer is present in the vicinity of the work and discharge to storm drain is not allowed by the agency having jurisdiction, the District may require the use of a water truck to transport the water to a suitable location.
- F. Connections shall be made with as little change as possible in the grade of the new main. Where the connection creates a high or low spot in the line, a standard air valve or blow off assembly shall be installed as directed by the District.

- G. Where connections are made to existing valves, the Contractor shall furnish and install all temporary blocking, steel clamps, shackles, and anchors as required by the District, and they shall replace the valve riser box and cover and adjust the valve cover to the proper grade in accordance with these specifications. The District will operate all existing valves. All valves, existing or newly installed, shall be readily accessible at all times to the District for emergency operation.
- H. New pipelines shall not be connected to existing facilities until the new pipelines have been successfully tested and disinfected by the Contractor and accepted by the District.
- I. Tapping connection can be made to the existing system while it is either in service or shut down depending on the District's prior direction. Tapping connection shall be made per Section 15050 when the existing system is required to be maintained in service during connection.
- J. Size-on-size connections shall be made using a cut-in tee. Size-on size connections may be made using a hot tap only under exceptional circumstances and with special permission from the District.
- K. All saddle connections into existing sewerlines shall be made with a wye saddle. Saddles shall conform to the applicable provisions of the section for the existing sewerline material.

3.02 REMOVAL FROM SERVICE OF EXISTING MAINS AND APPURTENANCES

- A. Existing mains and appurtenances shall be removed from service at the locations shown on the plans or as directed by the District.
- B. Existing pipe and appurtenances removed from the ground will require backfill and repair of surface in accordance with Section 02223.
- C. Removed pipe and appurtenances shall be temporarily stockpiled on the job in a location that will not disrupt traffic or be a safety hazard, disposed of in a proper manner (as determined by the District). The Contractor shall remove and dispose of all removed pipe at his own expense.
- D. Before excavating for installing mains that are to replace existing pipes and/or services, the Contractor shall make proper provisions for the maintenance and continuation of service as directed by the District unless otherwise specified.
- E. Water services shall be abandoned by one of the following methods, or as directed by the District:
 - 1. The service line shall be cut 6 inch from the corporation stop and the corporation stop shall be closed and capped.
 - 2. Pipeline shall be shut down, corporation stop removed from the saddle, and service saddle plugged. The abandoned service line shall be removed at the request of the District.
- F. Asbestos Cement Pipe (ACP) shall be cut, removed and disposed of in a proper manner. The Contractor will be responsible for the proper manifesting of the ACP at an authorized disposal site. See Section 15072 for additional requirements.

- G. Pipe shall be abandoned in place only with special permission from the District. Abandoned pipe shall be filled with grout. Pipe to be abandoned shall be exposed or tapped at the far end (or ends) from where the grout is being introduced into the pipe to allow for visual verification by the District that the grout has reached the end of the pipe. Any differences require the Contractor to submit a plan for District acceptance.

3.03 CUTTING AND RESTORING STREET SURFACING

- A. In cutting or breaking up street surfacing, the Contractor shall not use equipment that will damage adjacent pavement.
- B. All asphalt and/or Portland cement concrete surfaces shall be scored with sawing equipment of a type meeting the approval of the city or agency having jurisdiction; providing however, that any cement concrete base under an asphaltic mix surface will not be required to be scored by sawing. Existing paving surfaces shall be saw cut back beyond the edges of the trenches to form neat square cuts before repaving is commenced.
- C. Pavement, sidewalks, curbs, or gutters removed or destroyed in connection with performance of the work shall be saw cut to the nearest score marks, if any, and shall be replaced with pavement sidewalks, curbs, or gutters of the same kind, or better, by the Contractor in accordance with the latest specifications, rules, and regulations and subject to the inspection of the agency having jurisdiction over the street or highway.
- D. Aggregate base shall be placed beneath the restored pavement to the thickness required by the agency having jurisdiction.

END OF SECTION

SECTION 01330

SUBMITTAL PROCEDURES

PART 1 GENERAL

1.01 SECTION INCLUDES

- A. General procedures and requirements for submittals

1.02 SUBMITTALS

- A. Submit two hard copies and an electronic copy of submittals unless otherwise stated. Only an electronic copy will be returned to the Contractor.
- B. Number submittals using numbering system as directed by the District.
- C. Shop Drawing Transmittal Form. The form included at the end of this section shall be used unless otherwise directed by the District. Submit a separate form for each submittal number. Submittals without a completed the Contractor's Transmittal Form attached to each copy of each submittal listed in Schedule of Submittals will be returned without review and stamped "REJECTED/RESUBMIT AS SPECIFIED."
- D. Exceptions and departures from Contract Documents shall be clearly noted, along with brief justification for each exception or departure. The District's review or acceptance of submittals shall only constitute acceptance of the following:
 - 1. Portions of submittal in compliance with Contract Documents
 - 2. Exceptions or departures expressly noted on the Contractor's submittal as "exceptions" or "departures" and accepted in writing by the District
 - 3. Exceptions or departures that the District may by chance discover, acknowledge, and accept in writing, in the District's response to said submittal
- E. In the event a submittal's exception or departure from Contract Documents is neither noted by the Contractor on their submittal nor acknowledged and expressly accepted by the District, the Contract shall remain unchanged. The District's failure to discover all exceptions and departures in submittals whether intentional or unintentional on the Contractor's part shall in no way relieve the Contractor of any Contract responsibilities.
- F. Stock or standard drawings will not be accepted for review unless full identification and supplementary information is shown thereon in ink or typewritten form.
- G. Review of submittals shall proceed as follows:
 - 1. Submit specified quantity of complete submittals together with the Contractor's submittal forms to the District for review. Fold submittals to approximately 8 ½ inches by 11-inches.

2. Submittals will be stamped "ACCEPTED", "ACCEPTED AS NOTED", "REVISE AS NOTED/RESUBMIT", "REJECTED/RESUBMIT AS SPECIFIED," "NO ACTION REQUIRED," or "SUBMITTAL NOT REQUESTED, RETURNED WITHOUT REVIEW." Three copies with letter of transmittal will be returned to the Contractor.
 3. If drawing or data is returned stamped "ACCEPTED", "ACCEPTED AS NOTED", "NO ACTION REQUIRED," or "SUBMITTAL NOT REQUESTED, RETURNED WITHOUT REVIEW." No further resubmittals will be required for that item.
 4. If drawing or data is stamped "REVISE AS NOTED/RESUBMIT," or "REJECTED/RESUBMIT AS SPECIFIED," make necessary corrections and resubmit documents as required in Instruction 1. The Contractor's submittal form transmitting revised documents shall show that documents comprise a resubmittal. Revisions and re-submittals shall be numbered as Revision #1, Revision #2, or as appropriate.
 5. If changes other than those noted by the District are made on a submittal before resubmittal, note such changes on resubmittal.
 6. Revise and resubmit submittals as required, until confirmation of compliance with plans and specifications is obtained.
- H. Costs incurred by the District for second and subsequent re-submittals will be deducted from payment due to the Contractor.
- I. Allow no less than 30 calendar days for review and response to submittals. Review may be delayed if contingent on receipt of other submittals. Upon timely written request by the Contractor, the District will make reasonable efforts to shorten review periods which may fall on the Contractor's critical path.
- J. Correct and resubmit rejected submittals within 14 calendar days.
- K. Do not order products or begin work described in required submittals until such submittals have been reviewed and returned by the District stamped "ACCEPTED" or "ACCEPTED AS NOTED". The Contractor's acceptance of delivery of products prior to receipt of the District's satisfactory return of applicable submittals shall be at the Contractor's risk.
- L. Review of submittals by the District shall extend solely to the general type and layout of the Work and shall not be construed as relieving the Contractor of full responsibility for adequacy and accuracy of submitted designs and details shown in submittals.

1.03 INITIAL SUBMITTAL

- A. Submit the following within 48 hours after contract execution:
1. Names and addresses of manufacturers furnishing products valued greater than either 4 percent of contract value or \$40,000, whichever is less. State locations of shops at which manufacture will take place. State whether products are already designed or in production. Include a brief description of products proposed, including sizes and catalog numbers.
 2. Letter addressed to the District identifying Contractor's superintendent, safety officer, and traffic control coordinator, including emergency telephone numbers and signature authorization, and listing names, addresses and telephone numbers for subcontractors.

SUBMITTALS ON DISTRICT'S REQUEST – SUPPLEMENTAL INFORMATION

- B. Detailed construction schedule updates shall be submitted, with monthly pay requests to describe scheduling of elements of construction requiring the District's or the Contractor's coordination with public, or other private parties or public agencies.
- C. Supplemental information will be requested for "accepted equals" and may be requested when there is a question whether a manufacturer's product conforms to Contract Documents. The District reserves the right to require submittal of supplemental information as described herein before acceptance of product.
- D. Certification of compliance with listed reference standards shall be submitted by manufacturers upon the District's request. Failure of the District to request certification of compliance shall not serve as waiver of the Contractor's duty to comply with reference standards.
- E. Transcripts of results of acceptance tests, performed at point of manufacture of products furnished, shall be submitted by manufacturers upon the District's request.
- F. Samples shall be submitted upon the District's request.
- G. Names and addresses of nearest local service representatives maintaining technical service, personnel, and complete inventory of spare parts and accessories shall be submitted upon the District's request.
- H. List of three installations in which products are now in regular operation, which are comparable in size, capacity and rating with those required in the Contract Documents shall be submitted upon the District's request. Include listing of size, capacity, or rating of each installation. Include name and telephone number of at least one reference responsible for operations at each installation whom the District may contact.

1.04 PROGRESS REPORTS

- A. Daily log shall be submitted by the Contractor's superintendent on a one page form provided by the District. These logs shall be detailed with activities that took place during each day. Submit logs daily to the District by the end of following workday.
- B. Schedule updates shall be submitted with monthly pay requests. If Work falls behind schedule, monthly pay requests shall include revised schedules to demonstrate how the Contractor intends to bring work back on schedule.
- C. Record drawings, consisting of one set of full size annotated blueline plans and other drawings forming a part of contract, showing installed locations of improvements and all changes made during construction shall be available to the District for inspection throughout the project. Record all deviations from Contract Documents, including accepted change orders, using additional sketches or ink revisions, immediately after installing each portion of the Work. Show locations of underground piping, conduit, sensor lines, valves, capped ends, branch fittings, pull boxes and other Work. Keep one current record copy of Contract Documents, addenda, supplementary drawings, working drawings, change orders and clarifications at site and in good order. Report changes and deviations promptly to the District.

- D. Partial payment requests may be withheld if daily logs, schedule updates, or record drawings are damaged, lost or not kept current to satisfaction of the District.

1.05 CONTRACTOR’S NOTICE OF PENDING DELAY CLAIM

- A. In the event a delay claim is foreseen by the Contractor, the Contractor shall immediately notify the District in writing. Following said notice, the Contractor shall have no more than seven calendar days to furnish follow-up information as is required by the District to allow the District to act judiciously to minimize losses. At a minimum, said information shall consist of a letter identifying and substantiating the cost of the expected claim per day of delay accompanied by a schedule showing any available float and delay impact on overall schedule.

1.06 SHOP DRAWINGS AND PRODUCT DATA

- A. Shop drawings shall be defined as job-specific drawings prepared to scale wherever possible and shall include the project name and contract number on the shop drawing.
- B. Except where preparation of a submittal is contingent upon acceptance of a prior submittal, the Contractor shall make every reasonable effort to combine all submittals relating to same class or portion of Work into a common package, regardless of the variety of trades or types of equipment that may be required to construct that portion of Work. e.g. all above ground piping, fittings, valves, actuators, pipe stands, couplings, flow meters and appurtenances shall be submitted as one package for review.
 - 1. Packages that are clearly incomplete will be returned without review.
 - 2. To facilitate approval of critical path items or to facilitate the Contractor’s communication with multiple suppliers and subcontractors, packages may contain several submittals from several suppliers so long as all relevant submittals are contained in the package.
 - 3. Where expedited review of a single submittal within a package is desired to facilitate critical path items, notify the District in writing to request expedited review of said item. The Contractor’s request for expedited review of a portion of a package of submittals shall be taken as full acceptance of responsibility by the Contractor for any subsequent field modifications or substitutions later found necessary to correct any lack of coordination between expedited submittals and other submittals or to correct any lack of coordination between expedited submittals and Contract Documents not brought to the District’s attention at time of submittal.
- C. Catalog cuts may be manufacturer’s pre-printed drawings and need not include the project name. However, where multiple products or options are shown in the same catalog cut, the product or option being furnished shall be clearly delineated as specified below.
- D. All submittals shall show US units. For submittals prepared in foreign countries where manufacturer’s literature is printed solely in metric units, the Contractor may make hand annotations to convert to US units as long as annotations are clear and legible. Submittals not bearing US units will be returned without review.
- E. Submittals bearing text in languages other than English will be returned without review.
- F. Shop drawings for piping shall include the following:

MOULTON NIGUEL WATER DISTRICT

1. Key or index showing locations of spools and fittings
 2. Order of installation. Each spool shall receive a unique mark number. No other spool or fitting, even on separate pipelines or casings included in the contract, shall have the same mark number. The sequential order of the mark numbers shall correspond to a logical order of installation for each pipeline.
 3. Laying lengths, dimensions, clearances and tolerances for all spools and fittings
 4. Clearly legible drawing showing each pipe fitting and/or spool in plan view and in profile
 5. Station and invert elevation of all grade changes and changes in horizontal alignment
 6. Slopes of pipe not vertical or horizontal
 7. Horizontal and vertical alignment data for all curves, bends, tees and outlets
 8. Couplings and end types of all pipe, spools, fittings, outlets and adjacent valves or pipeline equipment
 9. Proposed pipeline linings and coatings including thicknesses
 10. How connections will be made between Work under this contract and existing work or work under other contracts
 11. Pipe, and valve support sizes and locations including anchor bolt sizes and embedments
 12. Relationship of piping to other Work
- G. Shop drawings for valves or pipeline equipment shall include the following:
1. Laying lengths and dimensions, clearances, tolerances and end types
 2. Weight and type of valves or equipment
 3. Valve port sizes and tolerances
 4. Dimensions and orientation of actuators and pilot systems, locations of actuator stops
 5. Proposed linings and coatings
 6. Performance characteristics
 7. Parts and materials lists and ratings and details of appurtenances to be furnished, along with references to appropriate ASTM, Federal Specifications and other reference standards and grades
 8. Piping and conduit attachments and sizes
- H. Shop drawings for equipment shall include the following:
1. Dimensions, clearances and floor space requirements
 2. Weight and type of equipment
 3. Location where product will be installed
 4. Anchor bolt sizes and embedments
 5. Finishes and coatings
 6. Performance characteristics

7. Parts and materials lists, ratings, and details of appurtenances shall be furnished, along with references to appropriate ASTM, Federal Specifications, and other reference standards and grades
8. Piping and conduit attachments and sizes
- I. Shop drawings for replacement items shall include field measurements needed to verify fit in existing spaces.
- J. Catalog data shall clearly indicate applicable items when several products are covered on one page. Indicate on submitted catalog data, specification section or plan reference being satisfied.
- K. Installation or application instructions shall be Manufacturer's printed instructions including warranty requirements, clearances required and proper field procedures to deliver, handle, install and prepare product for use. In the absence of Manufacturer's published literature, ASTM, AWWA, or trade standards for proper installation will usually be accepted. If no instructions at all are submitted for installing or applying an item of Work, the District reserves the right to stop work on subject item at any time, and to retain experts of the District's choosing to prepare appropriate installation or application instructions to control the Contractor's work. Installation instructions shall include recommended bolt torques for assembly and installation of bolted items.
- L. Operation and maintenance instructions shall be Manufacturer's printed instructions for correct operation and maintenance procedures for each product, along with data which must accompany the manual as directed by current regulations of governmental agencies. Include operating instructions for each piece of equipment. Describe equipment function, operating characteristics, limiting conditions, operating instructions, startup procedures, normal and emergency conditions, regulation and control, and shutdown. Include preventative maintenance instructions. List warranty requirements. Explain and illustrate preventative maintenance tasks. Include lubrication charts, lists of acceptable lubricants, trouble shooting instructions, and lists of required maintenance tools and equipment. List recommended spare parts, their costs, and ordering information for at least one manufacturer who can supply these parts. Index instructions for easy reference. Include information for installed equipment only.
- M. Manufacturer's Statement of Responsibility shall be a copy of the attached form, signed by an authorized factory representative for the manufacturer whose product is being furnished.
- N. Certificate of compliance shall certify that the materials or procedures have been sampled, tested, and found to comply with applicable reference standards, and shall be accepted by the District prior to shipping items described therein.
- O. Engineering calculations shall be clear and legible, shall follow recognized engineering principles, and shall be sufficiently detailed to permit confirmation of the procedures used. Where published tables or charts are included in calculations, clearly show design or load variables used to make selection, highlighting applicable columns or rows in tables and highlighting intersecting variables on chart axes. Engineering calculations shall demonstrate compliance with current state and local codes, applicable standards, and contract requirements. Calculations shall be sealed by a registered engineer licensed in State of California. Calculations or drawings bearing seals with expired expiration dates will not be accepted.

MOULTON NIGUEL WATER DISTRICT

- P. Foundry or test record transcripts shall fully describe required tests in accordance with specified test standards, shall certify that factory quality control, testing, and inspection requirements have been successfully completed and shall be accepted by the District prior to shipping items described therein.
- Q. Furnish the following submittals

SUBMITTAL	DESCRIPTION
Manufacturer's Written Acceptance of Installation (where "Manufacturer's Statement of Responsibility" is required)	Written acceptance of installation of products shall be certified and submitted by authorized factory representative. This written acceptance shall state that factory authorized representative has inspected installation, alignment, lubrication, and operation of furnished equipment and found it to fully comply with specified design and warranty requirements and are ready for safe operation.
Warranty	Unless otherwise stated, furnish one-year warranty from date of final acceptance.

- R. The District's review of submittals shall be limited to review of products to be incorporated in Work and to remain in place upon project completion. The Contractor shall have sole responsibility at all times for construction means, methods and jobsite safety. The Contractor shall retain services of California-licensed civil, structural, or traffic engineer, as appropriate, to design and prepare plans for necessary safety equipment required by OSHA, Cal OSHA and other state and local regulatory authorities during construction, and to prepare summary documents for the Contractor's use for accomplishing said work including, but not limited to sheeting, shoring, trench plating, excavation protection, falsework, formwork, scaffolding, barricading, pedestrian safety and traffic control. Originals of summary documents, signed and sealed by engineer of record who prepared them, shall be submitted solely as proof this requirement has been fulfilled. Since the Contractor has sole responsibility for means, methods and jobsite safety, review of said documents will be limited to verifying preparing engineer's registration is current and that engineer of record has no active complaints filed against them with the California Board for Professional Engineers and Land Surveyors.
- S. Use of contract drawing reproductions for shop drawings is subject to rejection.

1.07 SAMPLES

- A. Furnish samples, finished as specified, and as intended to be used on or in Work. Send samples to the District, carriage prepaid.
- B. Submit samples at least 21 days before date by which the District's acceptance is required. Allow at least 14 days for review and return of samples.
- C. Submit two of each sample, except for field samples. Attach completed the Contractor's submittal form to the sample. List all items being transmitted, stating proposed use and location, product, color, trade name, lot, style, and model as appropriate.
- D. Resubmit samples until acceptable. One of each sample will be returned to the Contractor upon acceptance.

- E. Samples of finishes shall be 8" x 10" and shall be of minimum thickness consistent with sample presentation. In lieu thereof, submit actual full-size item.
- F. Samples of value may be returned to the Contractor for use in Work after review, analysis, comparison, and/or testing as may be required by the District.
- G. Furnish one sample of accepted products, colors, or textures to the District for final record. Show identification previously described on the back of the sample, including, if finish sample, manufacturer, mix proportion, name of color, building, the Contractor, subcontractor, and any surfaces to which applied.

1.08 CONSTRUCTION PHOTOGRAPHS

- A. Preconstruction photographs shall be submitted to the District before Work is performed which has potential to disturb or modify public or private property not owned by the District. Photographs shall be of sufficient quality and thoroughness to fully document preexisting damage or wear to photographed property for which the Contractor or the District might be asked to compensate property owner were it not for photographic evidence of preexisting damage. Where existing cracks in concrete, masonry or other materials are wider than the thickness of a dime, include a dime or similar visual standard in a photo or video for reference.
- B. Failure by the Contractor to submit preconstruction photographs may be taken by the District as evidence that subsequent claims by property owners for damage to their property can be rightfully attributed to the Contractor's actions.

1.09 NOTIFICATION OF AFFECTED RESIDENCES AND BUSINESSES

- A. Written notification, with the Contractor's 24-hour emergency phone number, shall be provided to residences and businesses fronting the project on either side of street. Notify these parties 72 hours in advance of construction which will affect these properties. Door-hangers or other means of notification shall be submitted to and accepted in advance by the District. For Capital Improvement projects, the District will notify residents and businesses.

1.10 PAYMENT

- A. Payment for submittals and re-submittals will be included in the bid price for those items of Work for which the submittals are required.

PART 2 PRODUCTS (NOT USED)

PART 3 EXECUTION (NOT USED)

END OF SECTION

MANUFACTURER'S STATEMENT OF RESPONSIBILITY

Project Name: _____

Specification Section Number: _____

Item: _____

Serial Numbers: _____

District: _____

Contractor: _____

Supplier: _____

1. **We have reviewed the applicable sections of the Contract Documents** describing requirements for our product, including Sections entitled "Submittal Procedures," "Quality Requirements," "Product Requirements," "Starting and Adjusting," "Closeout Procedures," "Operating and Maintenance Data," "Demonstration and Training," "Basic Civil Engineering Requirements," and "Painting and Coating."

2. **Before shipping, we promise to review Contractor's submittals from other manufacturers** who will supply products that interface with our product, and may affect our product's performance. In addition, we promise to request and review data concerning quality of water, soils or any other materials which may contact or adversely impact performance of our product.

3. **Should we have cause to believe that our product is, for any reason, incompatible** with an interfacing product or material, we will inform the District of our concern before shipping our product. In such case, we will not ship our product until our concerns have been satisfactorily resolved.

4. **We further understand that the District reserves right to request a factory authorized representative's written acceptance of installation, application and/or erection of our product** as described in Section of Contract Documents entitled "Starting and Adjusting", before paying Contractor for our product.

Authorized Factory Representative

SHOP DRAWING TRANSMITTAL FORM

FROM: _____ DATE: _____
company name

PROJECT: _____

CONTRACT NUMBER: _____

TO: Moulton Niguel Water
District 26161 Gordon Road
Laguna Hills, CA
92653 attn: project
inspector

SUBMITTAL NO.: _____ ORIGINAL: Y / N REVISION NO.: _____
circle one

SUBJECT OF SUBMITTAL: _____

SPECIFICATION SECTION(S): _____

PLAN SHEET NUMBER(S): _____

CONTRACTOR'S CERTIFICATION: Check & Complete either (A) or (B) below:

(A) We have reviewed in detail and certify that the material, equipment, or construction procedures (s) contained in this submittal meet all the requirements specified in or shown on the Contract Documents, Construction Specifications and Construction Plans with no exceptions.

(B) We have reviewed in detail and certify that the material, equipment, or construction procedures (s) contained in this submittal meet all the requirements specified in or shown on the Contract Documents, Construction Specifications and Construction Plans except for the following deviations:

CONTRACTOR'S AUTHORIZED SIGNATURE:

SECTION 01550
BYPASS PUMPING

PART 1 GENERAL

1.01 SECTION INCLUDES

- A. Bypass pumping requirements

1.02 SUBMITTALS

- A. Bypass Pump Plan:
 - 1. Submit to the District for acceptance within 4 weeks of Notice to Proceed.
 - 2. Plan shall include, but not limited to, the following topics:
 - a. Number of primary, lag and standby pumps, product data sheets for the proposed pumps, discharge capacities of pumps, all related appurtenances (suction and discharge hoses/piping; valving; sensors or controls);
 - b. Calculation of static lift, friction losses, and flow velocity (include pump operating curves);
- B. Spill Prevention and Emergency Response Plan
- C. Spill Incident Report:
 - 1. Submit report within three (3) working days from the occurrence of the spill.
 - 2. Report shall include the following information related to the spill: Location, date, time, duration, spill volume, cause, and corrective actions.

1.03 QUALITY ASSURANCE

- A. Qualifications: The bypass pumping subcontractor shall have at least five (5) verifiable references of projects of a similar size and complexity as the proposed project performed by their firm within the last three years.
- B. Pollution Liability Insurance: The Contractor shall obtain and maintain an additional insurance coverage for Pollution Liability.

PART 2 PRODUCTS

2.01 DESIGN CRITERIA

- A. Flow Rates
 - 1. The bypass system shall be capable of pumping a minimum of 120 percent of the required peak flow rate after head and friction loss factors are accounted for.

2. Peak Dry Weather Flow may be used for single day bypass activities that will not commence in a rain event.
3. Peak Wet Weather Flow shall be used for rehabilitation activities that will commence in a rain event or for a bypass system that may remain in service overnight.
4. Flow rates may be available from the District. At discretion of the District, the Contractor shall be required to provide flow monitoring to verify flow rates.

B. Sound

1. The Contractor shall ensure the pumps and generators are “critically silenced” with a maximum allowable sound level of 70 dba at the nearest building façade or as otherwise required by agency having jurisdiction.

2.02 SYSTEM

A. Pumping System:

1. Provide redundant, identically sized, one hundred-percent backup bypass pumping system.
2. Provide minimum of two pumping units, duty and standby.
3. Each pump, including the backup pumps, shall be a complete unit with its own suction and discharge piping.
4. If electric power driven pumps are used, provide an emergency standby power generator even when the pumps are powered with commercial power.

B. Fuel Tanks:

1. Provide one (1) dedicated fuel tank for every single pump/generator, if fuel/generator driven pumps are used.
2. The Contractor shall provide a fuel level indicator outside each fuel tank.
3. The Contractor shall take the necessary measures to ensure the fuel supply is protected against contamination. This includes but is not limited to fuel line water traps, fuel line filters, and protecting fuel stores from precipitation.

PART 3 EXECUTION

3.01 BYPASS PUMPING

- A. Continuous full-time monitoring by a person qualified and trained to operate and maintain the bypass pumps and bypass system shall be provided by the Contractor.
- B. Fully install backup bypass pumping system and ensure it is operational and ready for immediate use.
- C. The Contractor shall demonstrate to the satisfaction of the District that both the primary and backup bypass pumping systems are fully functional and adequate, and shall certify the same, in writing, in a manner acceptable to the District.
- D. Provide traffic ramps where hoses/pipes cross traffic ways.

3.02 SPILL PREVENTION AND EMERGENCY RESPONSE

- A. The Contractor shall comply with the District's policy of zero spills and is responsible for preventing and containing any sewage spillage.
- B. The Contractor shall make every effort to eliminate spill risk by providing containment around bypass system and in the location that the sewer will be opened up.
- C. In case of a sewage spill(s), the Contractor shall act immediately without instructions from the District, to control the spill and take all appropriate steps to contain it.
- D. The Contractor is responsible for the recovery and legal disposal of any spilled sewage and liability arising from negligently causing a sewage spill and shall defend, indemnify, protect, and hold harmless the District, its agents, officers, and employees, from and against all claims asserted, or liability established for damages or injuries to any person or property resulting from any sewage spill caused or claimed to be caused by the Contractor's action or failure to take measures to prevent a spill. The Contractor shall also be responsible for payment of any fines and/or penalties assessed against the District for such sewage spills. The Contractor's duty to indemnify and hold harmless shall not include any claims or liability arising from the established sole negligence or willful misconduct of the District, its agents, officers or employees.

END OF SECTION

SECTION 01630

PRODUCT SUBSTITUTION PROCEDURES

PART 1 GENERAL

1.01 SECTION INCLUDES

- A. Procedures and requirements for substituting products

1.02 RELATED REQUIREMENTS

- A. Section 01330, Submittal Procedures

1.03 GENERAL REQUIREMENT

- A. In compliance with the provisions of Section 3400 of the Public Contract Code of the State of California, the Contractor will have thirty (30) calendar days after award of the contract to submit data substantiating a request for substituting any “or equivalent” items. Substitution requests shall be submitted and accepted by the District prior to the Contractor ordering materials.
- B. Standard Products - Where products are specified by reference standard, any product meeting the standards referenced may be used. Information on such products shall be submitted in accordance with the requirements of Section 01330.
- C. Proprietary Products – Where products or processes are specified or listed in the approved material list by trade, patent or proprietary name, said specification or approved material list, unless marked "no exceptions", shall be deemed to be followed by the words "or accepted equal accepted in writing by the District." In such case substitution of similar products as “accepted equals” will be considered under this section.
- D. Selection of Proprietary Product - Where more than one proprietary name is specified or listed in the approved material list, the Contractor may provide any one of the products specified. Only one manufacturer shall be used for each specific application throughout the Work notwithstanding that similar materials or equipment of two or more manufacturers or producers may be specified for the same application.
- E. Substitution Request Procedure - Submit a written request on the enclosed form for proposed substitutions to the District prior to deadline for receipt of substitution requests. Submit proposed substitutions relating to a particular subcontract or trade in a single package. If the District accepts any proposed substitutions, such acceptance will be set forth in an Addendum. No substitution will be considered after the deadline for receipt of substitution requests has expired. Requests for substitutions shall be accompanied by a non-refundable cashier’s check or money order for \$200 made out to the District to compensate the District for cost of reviewing each substitution request. Check shall clearly show project name and product or service submitted for review.

MOULTON NIGUEL WATER DISTRICT

- F. Contractor's Responsibility for Construction Modifications - Drawings have been detailed in compliance with dimensions and International Council of Building Officials (ICBO) Evaluation Report data for products specified. If proposed substitute product is accepted by the District, the Contractor shall assume both responsibility for construction modifications and additional costs required by reason of this acceptance. If substitution results in a decrease in cost, potential savings to the District may be submitted to the District for consideration.
- G. Systems of Like Manufacture - Where products are specified in groups to be furnished by one manufacturer, no substitution will be considered that is not similarly furnished by one manufacturer. Where the Contractor proposes to use a system of equipment other than that shown in the Contract Documents, the substitution shall be proposed as a complete system.
- H. No time extension will be allowed for substitution of materials.
 - 1. Submittals
 - a. Furnish the following submittals for substitution requests.

SUBMITTAL	DESCRIPTION
Substitution Request Form	Submit Substitution Request on form furnished at the end of this section.
Contractor's Certification of Performance and Assumption of Liability	Submit Certificate of Performance certifying that the proposed substitution is equal to or better in all respects to the product specified and that the proposed substitution will, in all respects perform the function for which it is intended.
Certificate of Compliance	Required as needed to substantiate Product Substitutions
Dimensional Data	Required for Product Substitutions
Material Samples	Required as needed to substantiate Product Substitutions
Manufacturer's Statement of Responsibility	Required at District's discretion for Product Substitutions. See form at end of Section 01330.
Foundry or Test Record Transcripts	Required as needed to substantiate Product Substitutions
Material List and Ratings	Required as needed to substantiate Product Substitutions
Names and Addresses of Nearest Local Manufacturer's Representatives	Required for Product Substitutions (Use allotted space on attached Substitution Request Form)
List of Three Local Product Installations	Names and contact information for three installations within a 100 mile radius of project completed within the prior three years. Required for Product Substitutions (Use allotted space on attached Substitution Request Form)
Manufacturer's Service Contract Statement of Qualifications	Required for installations of products which include optional maintenance service contracts
Warranty	Furnish warranty equal to or better than warranty required for specified product.

MOULTON NIGUEL WATER DISTRICT

- b. Determination of Equality - The burden of proof for demonstrating equality of the substituted item shall be the responsibility of the Contractor. Acceptance of such substitutions is entirely at the discretion of the District.
 - c. List of Accepted Substitutions - The District will issue to the Contractor a list setting forth those substitutions that have been accepted. No products proposed for substitution, shall be ordered before being accepted in writing by the District.
 - d. Products accepted as "accepted equals" shall, in the District's opinion, meet the following requirements:
 - 1) Products shall be of equal quality, substance, function, and color to those listed.
 - 2) Products shall be standard products of a reputable manufacturer having regularly been engaged for 5 years in manufacture of products furnished.
 - 3) Products shall have a reputation for assuring long-lasting trouble-free service.
 - 4) Factory-authorized, factory-trained, and competent service personnel, and stocked service parts shall be available within a 150 mile radius of the Work.
 - 5) Manufacturer shall be capable of certifying compliance with listed reference standards.
 - e. The District reserves the right to reject product substitutions solely on the basis of maintenance of economies of scale available to the District through standardizing on manufacturers and minimizing spare parts inventories.
 - f. Denial of Substitution - If, in the opinion of the District the proposed substitution is not equal to or better in every respect to that of the specified product, or was not submitted for acceptance in the manner outlined above, the Contractor shall furnish the specified products.
 - g. Responsibility for Coordinating Substitutions with Construction Trades – the Contractor shall inform all other trades, vendors, and subcontractors of the effects of substitutions on their work or products. Failure to notify shall not relieve the Contractor of their duty to make payments arising from alterations in specified products or methods needed to complete the Work in an approved and acceptable manner.
2. Contractor's Responsibility for Cost of Substitution Reviews
- a. The Contractor shall pay all costs incurred by the District to review Requests for Substitutions.
3. Responsibility for Spare Part Inventories
- a. Provide spare parts inventory to accommodate two years' typical maintenance. See technical specifications for further information for specific equipment items.
4. Substitution of "Inferior" Products
- a. Products not meeting the above requirements shall, for purpose of this contract, be deemed "inferior" even if product's only shortcoming is that the Contractor failed to submit a Substitution Request on said product prior to the stipulated deadline.
 - b. Substitution of "inferior" products shall not occur except where cost savings are offered to and accepted by the District in the form of a Change Order.

5. Bid Shopping and Reverse Auctions
 - a. Substitutions for products and services of Manufacturers, system integrators or subcontractors listed at time of bid and/or in the Contractor's initial Submittal will only be permitted under one or more of the following circumstances:
 - 1) Where the Contractor-listed manufacturer, system integrator, or subcontractor has gone out of business.
 - 2) Where the Contractor-listed manufacturer, system integrator or subcontractor has, in the District's opinion, failed to perform or no longer possesses both capability and willingness to perform to standard required by Contract Documents.
 - 3) Where the Contractor-listed manufacturer, supplier, or subcontractor increases price quoted to the Contractor above, that quoted at time of bid, and the Contractor submits evidence of this acceptable to District.
 - 4) Where the Contractor offers a credit to the District sufficient in the District's opinion to justify accepting the substitution in the form of a Change Order.

PART 2 PRODUCTS (NOT USED)

PART 3 EXECUTION (NOT USED)

END OF SECTION

SUBSTITUTION REQUEST FORM

TO: _____
 District

Address

City/State/ZIP

PROJECT NAME: _____

FROM CONTRACTOR: _____

We hereby submit for consideration the following product substitution of specified item for above project:

DRAWING OR SECTION NO.		SHEET NUMBER OR PARAGRAPH		SPECIFIED ITEM

PROPOSED SUBSTITUTION: _____

1. Attach complete dimensional information and technical data needed to substantiate product substitution, including ICBO reports and laboratory tests, if applicable.
2. Include complete information on changes to Drawings and/or Specifications which proposed substitution will require for its proper installation.
3. Where product substitutions are proposed at multiple locations, submit copies of plans showing in red each location where the product substitution is proposed.
4. Submit with request all necessary samples and substantiating data to prove equal quality and performance to that which is specified. Clearly mark manufacturer's literature to indicate equality in performance. Differences in quality of materials and construction shall be indicated.
5. Submit Manufacturer's Statement of Responsibility.

SUBSTITUTION REQUEST FORM

Fill in Blanks Below:

- A. Does the substitution affect dimensions shown on Drawings?
Yes___ No___ If yes, attach copy of plans and clearly indicate changes.
- B. Will the undersigned pay for the changes to the building design, including engineering, detailing and review costs caused by the requested substitution? Yes___ No___
- C. What effect does the substitution have on other trades?
1. _____
2. _____
- D. What effect does substitution have on applicable code requirements?
1. _____
2. _____
- E. What is the ICBO Approval Number: _____
- F. Differences between proposed substitution and specified item:
1. _____
2. _____
- G. List three installations where product is in use:
1. _____
2. _____
- H. Address of Authorized Manufacturer's Representative:

Representative

Address

City/State/ZIP
- I. Manufacturer's guarantees of the proposed and specified items are:
Same___ Different___ (Explain) _____
- J. District's share of cost savings if substitution is approved \$_____

SUBSTITUTION REQUEST FORM

**CONTRACTOR'S CERTIFICATION OF PERFORMANCE AND
ASSUMPTION OF LIABILITY FOR EQUAL PERFORMANCE**

I certify that the proposed substitution is equal to or better in all respects to the product specified and that the proposed substitution will, in all respects perform the function for which it is intended.

Submitted By:

Date: _____

Signature: _____

Title: _____

Firm: _____

Address: _____

Telephone: _____

For use by District:

_____ Accepted

_____ Accepted as Noted

_____ Not Accepted

_____ Received Too Late

By: _____

Date: _____

Remarks: _____

Concurrence By:

District

Signature must be by person having authority to legally bind their firm to the above terms. Failure to provide legally binding signature will result in retraction of approval.

SECTION 01650

PRODUCT DELIVERY, STORAGE, AND HANDLING REQUIREMENTS

PART 1 GENERAL

1.01 SECTION INCLUDES

- A. Transportation and handling, storage and protection of products

1.02 REFERENCED STANDARDS

- A. California Stormwater Quality Association (CASQA) Stormwater Best Management Practice Handbook for Construction latest edition
- B. ANSI/NSF 61 Drinking Water System Components – Health Effects

1.03 DELIVERY, STORAGE AND HANDLING

- A. Ship and deliver products to jobsite as follows:
 - 1. Do not ship, accept delivery of, or store items on site for which applicable submittals have not been accepted.
 - 2. Before shipping, operate valves, motors, pumps, actuators, and mechanical equipment at the factory to ensure products are complete and in working condition.
 - 3. Only products of accepted manufacturers shall be delivered to or stored at the site.
 - 4. Deliver products to the jobsite in manufacturer's original, unbroken, unopened, labeled packaging containers or bundles. Tag or label packages, containers, or bundles as needed to identify contents and name of equipment of which contents form a part.
 - 5. Deliver large multi-component assemblies in sections that facilitate field handling and installation.
 - 6. Oil-lubricated gearing, bearings, and other lubricated components shall be shipped with oil soluble protective coating as described in the warranty requirements or as recommended by the manufacturer. For parts contacting potable water, coating shall be NSF-approved. Coating shall provide protection for one year after final acceptance.
- B. Store products at jobsite as follows:
 - 1. Store materials per manufacturer's recommendations, and in a protected area at a temperature between 35 degrees F and 110 degrees F.
 - 2. Store products so as to preserve their quality and fitness for the Work. Locate stored products and equipment to be incorporated in the Work to facilitate prompt inspection. The Contractor shall be responsible for damage or loss to products until Final Acceptance.

MOULTON NIGUEL WATER DISTRICT

3. Protect products against moisture, weather, temperature extremes, dust, debris, tampering, theft, vandalism, ultraviolet radiation, or damage from improper handling, storage, or exposure. Protect exposed metals from rust and corrosion even for items which may be sandblasted or otherwise cleaned before painting.
4. Store items not designed for outdoor exposure off the ground and under cover.
5. Store cementitious materials in weather-tight spaces. Keep free from moisture.
6. Store aggregate in well-drained area to minimize change in moisture content. Prevent contamination by other materials.
7. Store fasteners and connectors in original unopened containers until used.
8. Ventilate materials subject to corrosion or moisture damage to prevent condensation.
9. Any corrosion evident prior to final acceptance shall be removed, or the product shall be removed or replaced.
10. Cover plastic and similar brittle items to protect from sun exposure and temperature extremes.
11. Cover stored materials with tarpaulin or other covering to prevent soiling or exposure to weather. Fasten coverings to prevent removal by wind.
12. Store flammable products to conform with City, County, State, and Federal safety codes for storage of flammable materials.
13. Cover, plug, or cap pipe ends, valve ends and equipment openings with rubber, plastic or canvas to prevent intrusion or contamination.
14. Stringing of pipe along right of way shall be done in a manner that will not interfere with free passage of vehicles.
15. Do not store pipe on roadway or parkway of residential streets for more than 10 days.
16. Store items in accordance with requirements of project Storm Water Pollution Prevention Plan (SWPPP), if applicable. If a SWPPP has not been prepared for the project, store items in accordance with the appropriate best management practices (BMP's) listed in the California Stormwater Quality Association (CASQA) Stormwater Best Management Practice Handbook for Construction latest edition. Comply with all City, County, State, and Federal pollution prevention laws and permits.
17. Notify the District in writing if delivered or stored product is damaged. Exterior surfaces of delivered items shall be in perfect unblemished condition. Do not repair damaged products without prior written approval.

C. Handle products as follows:

1. Handle products with care, using proper equipment according to manufacturer's recommendations. Lift large heavy items only at points designated by manufacturer. Do not drop, drag, bump, bend or handle products in a manner that causes abrasions, bruises, cracks, mars, scars, scratches or other damage. Use padded slings and hooks for lifting as needed to prevent damage. Improper handling shall be cause to reject mishandled products.

MOULTON NIGUEL WATER DISTRICT

2. Coated pipe, valves and other products shall be lifted, lowered or suspended using rubber or canvas belt slings or pneumatic-tired cradles. Slings shall equal or exceed pipe or product diameter. Do not handle coated products using ropes, hooks, chains, calipers or cables. Store such materials on padded skids.
3. Inspect each product item for damage, defects, completeness and correct operation before installing.
4. Before installation, swab joints and interiors of piping materials to remove foreign matter.
5. Clean and protect machined surfaces and shafting from corrosion using proper type and amount of coating as described in warranty requirements to assure protection to one year after final acceptance.
6. Maintain records for the District's review of deliveries to show Contractor's order number, purchase order number and equipment number. Include labeling or shipping tag in records.

1.04 WARRANTY REQUIREMENTS

- A. Manufacturer's instruction and warranty requirements for delivery, storage and handling of products shall be strictly followed.

PART 2 PRODUCTS (NOT USED)

PART 3 EXECUTION (NOT USED)

END OF SECTION

SECTION 02200

EARTHWORK

PART 1 GENERAL

1.01 SECTION INCLUDES

- A. Excavation, backfilling, materials, testing, and shoring for structures and site earthwork

1.02 RELATED REQUIREMENTS

- A. Section 02223, Trenching, Backfilling, and Compacting
- B. Section 03300, Concrete
- C. Section 03461, Precast Reinforced Concrete Manholes
- D. Section 03462, Precast Concrete Vaults
- E. Section 03463, Grease Interceptors

1.03 DEFINITIONS

- A. Pavement and street zones: as specified in Section 02223
- B. Upper Backfill Zone: The upper backfill zone is defined as the backfill to the full width of the excavation from the top of the structure to the bottom of the street zone in paved areas or to the finished surface in unpaved areas.
- C. Structural Backfill Zone: The structural backfill zone is defined as the backfill from the top of the structure to the bottom of the excavation, extending the full width of the excavation.
- D. Over-excavation: excavation below the design subgrade depth
- E. Geotechnical Engineer: The Geotechnical Engineer provided by the District or agency having jurisdiction, unless stated otherwise

1.04 REFERENCED STANDARDS

- A. California Division of Occupation Safety and Health (Cal/OSHA)
 - 1. Cal/OSHA Sub-chapter 4, Article 6: Excavations

1.05 SUBMITTALS

- A. Submit drawings of excavation and shoring, sheeting or bracing for worker protection in accordance with the General Provisions.
- B. Submit six (6) copies of a report from a testing laboratory verifying that gravel base and structural backfill conforms to the specified gradations or characteristics.

- C. Test reports on borrow material
- D. Other tests and material reports as required

1.06 PERMITS

- A. Obtain permit with the California Division of Occupational Safety and Health where trenches or excavations exceed 5-feet deep.
- B. All work shall conform to the specifications and requirements of the State of California Department of Transportation, the Orange County Public Works, the city having jurisdiction, and other agencies involved.
- C. The Contractor shall keep a copy of all the required permits in the job site and comply with all the terms and conditions of said permits.

PART 2 PRODUCTS

- A. Native earth backfill, imported backfill material, granular material, imported sand, and crushed rock shall conform to the requirements of Section 02223.

PART 3 EXECUTION

3.01 PREPARATION

- A. Conform to requirements of Section 02223.

3.02 DE-WATERING

- A. Conform to requirements of Section 02223.
- B. Provide and maintain means and devices to continuously remove and properly dispose of all water entering the excavation during construction of the structure and all backfill operations.
- C. Do not allow water to rise in the excavation until backfilling around and above the structure is completed.

3.03 STRUCTURE EXCAVATION

- A. Structure excavation shall include the removal of all material of whatever nature necessary for the construction of structures and foundations in accordance with the plans, these specifications, and the geotechnical report.
- B. The sides of excavations for structures shall be sufficient to leave at least a 2-foot clearance, as measured from the extreme outside of form work or the structure, as the case may be.
- C. Surplus material shall be disposed of by the Contractor in accordance with Section 02223.

D. Over-Excavation:

1. Over-excavate below subgrade per the requirements of the geotechnical report.
2. Inadvertent Over-Excavation
 - a. Where excavation is inadvertently carried below design depths, suitable provision shall be made by the Contractor to adjust construction, as directed by the District, to meet requirements incurred by the deeper excavation.
 - b. Native backfill will not be permitted to correct over-excavation beneath structures.
 - c. Over-excavation shall be corrected by backfilling with ¾" crushed rock or concrete, as directed by the District.

3.04 SHEETING, SHORING, AND BRACING

- A. Conform to requirements of Section 02223.
- B. The sheeting, shoring, and bracing shall be arranged so as not to place any stress on portions of the completed work.

3.05 BACKFILL

- A. After structures and foundations are in place, backfill shall be placed to the original ground line or to the limits designated on the plans and in accordance with the geotechnical report.
- B. No material shall be deposited against concrete structures until the concrete has reached the 28-day compressive strength as tested per Section 03300. Where backfill is to be placed on both sides of the wall, the backfill shall be placed uniformly on both sides. Where backfill is to be placed around a structure, the backfill shall be placed at a uniform rate around the structure.
- C. Backfill shall not be placed against the walls of structures that are laterally restrained or supported by suspended slabs or slabs on grade until the slab is poured and the concrete has reached the specified compressive strength.
- D. Imported sand or granular material shall be placed in horizontal layers not exceeding 12 inches in depth.
- E. Excavations shall be backfilled as work permits, but not until completion of the following:
 1. Acceptance of construction below finish grade including, where applicable, damp proofing, waterproofing, and perimeter insulation
 2. Inspection, testing, approval, and recording locations of underground utilities
 3. Removal of concrete formwork
 4. Removal of shoring and bracing, and backfilling of voids with satisfactory materials. Cut off temporary sheet piling driven below bottom of structures and remove in manner to prevent settlement of the structure or utilities, or leave in place, if required.
 5. Removal of trash and debris
 6. Permanent or temporary horizontal bracing is in place on horizontally supported walls.

3.06 COMPACTION REQUIREMENTS

- A. Minimum compaction requirements are as follows. Requirements of the jurisdictional agency govern.
 - 1. Backfill in street zone: 90% relative compaction
 - 2. Structural backfill: 90% relative compaction
 - 3. Gravel base: 90% relative compaction
 - 4. Adjacent to existing structures: 95% relative compaction
 - 5. Under new structures: 95% relative compaction
 - 6. Rock refill for over-excavation: 90% relative density
- B. Each layer of backfill material shall be moistened and thoroughly tamped, rolled, or otherwise compacted to the specified relative density.
- C. Carefully operate compaction equipment near structures to prevent their displacement or damage. Structural fill is to be placed and compacted in uniform layers around all sides of the structure.

3.07 RESTORATION

- A. Pavement replacement shall be in accordance with the requirements of the city or the agency having jurisdiction.

3.08 TOLERANCES FOR SITE EARTHWORK

- A. Top surface of subgrade: 1/2-inch from specified grade

3.09 FIELD QUALITY CONTROL

- A. All grading, excavation, backfill, and compaction, shall be performed under inspection by a California licensed Geotechnical Engineer.
- B. Testing for compaction shall conform to Section 02223.

END OF SECTION

SECTION 02223

TRENCHING, BACKFILLING, AND COMPACTING

PART 1 GENERAL

1.01 SECTION INCLUDES

- A. Trench excavation, backfilling, and compacting

1.02 RELATED REQUIREMENTS

- A. Section 02200, Earthwork
- B. Section 15056, Ductile Iron Pipe and Fittings
- C. Section 15057, Copper, Brass, and Bronze Pipe Fittings and Appurtenances
- D. Section 15064, PVC Pressure Distribution Pipe
- E. Section 15066, Gravity Sewer Pipelines
- F. Section 15068, Sewer Laterals

1.03 DEFINITIONS

- A. Pipe Zone: The pipe zone shall include the full width of trench from the bottom of the pipe or conduit to a horizontal level 12 inches above the top of the pipe.
- B. Pipe Bedding: The pipe bedding shall be defined as a layer of material immediately below the bottom of the pipe or conduit and extending over the full trench width in which the pipe is bedded. Thickness of pipe bedding shall be as shown on the drawings or as described in these specifications for the particular type of pipe installed.
- C. Over-excavation: Excavation below the design subgrade depth
- D. Geotechnical Engineer: The Geotechnical Engineer provided by the District or agency having jurisdiction, unless stated otherwise

1.04 REFERENCED STANDARDS

- A. ASTM International
 - 1. ASTM D75: Standard Practice for Sampling Aggregates
 - 2. ASTM D1556: Standard Test Method for Density and Unit Weight of Soil in Place by Sand-Cone Method
 - 3. ASTM D1557: Standard Test Methods for Laboratory Compaction Characteristics of Soil Using Modified Effort

4. ASTM D2937: Standard Test Method for Density of Soil in Place by the Drive-Cylinder Method
 5. ASTM D4254: Standard Test Methods for Minimum Index Density and Unit Weight of Soils and Calculation of Relative Density
 6. ASTM D6938: Standard Test Methods for In-Place Density and Water Content of Soil and Soil-Aggregate by Nuclear Methods (Shallow Depth)
- B. California Department of Transportation (Caltrans)
1. Test 217, Method of Test for Sand Equivalent
- C. California Division of Occupation Safety and Health (Cal/OSHA)
1. Cal/OSHA Sub-chapter 4, Article 6: Excavations

1.05 SUBMITTALS

- A. Data sheets for all materials
- B. Certificates that materials meet requirements of this specification
- C. Drawings of excavation and shoring, sheeting or bracing
- D. Calculations

1.06 PERMITS

- A. Obtain permit with the California Division of Occupational Safety and Health where trenches or excavations exceed 5-feet deep.
- B. All work shall conform to the specifications and requirements of the State of California Department of Transportation, the Orange County Public Works, the city having jurisdiction, and other agencies involved.
- C. The Contractor shall keep a copy of all the required permits on the job site and comply with all the terms and conditions of said permits.

PART 2 PRODUCTS

2.01 NATIVE EARTH BACKFILL

- A. The use of native earth as backfill material will require the acceptance of the District in all cases.
- B. Native earth backfill, acceptable for use, shall be fine-grained material free from roots, debris, and rocks with a maximum dimension not larger than 3 inches.
- C. Native backfill shall not be used in the pipe zone.

2.02 IMPORTED BACKFILL MATERIAL

- A. Whenever the excavated material is not suitable for backfill, the Contractor shall arrange for and furnish suitable imported backfill material that is capable of attaining the required relative density.
- B. The Contractor shall dispose of the excess excavated material as specified in this section. Backfilling with imported material shall be done in accordance with the methods described herein.

2.03 IMPORTED SAND

- A. Imported sand shall have a minimum sand equivalent of 30 per Caltrans Test 217 with 100% passing a 3/8 inch sieve and not more than 20% passing a 200-mesh sieve.

2.04 CRUSHED ROCK AND GRAVEL

- A. Crushed rock shall be the product of crushing rock or gravel. Fifty percent of the particles retained on a 3/8 inch sieve shall have their entire surface area composed of faces resulting from fracture due to mechanical crushing. Not over 5% shall be particles that show no faces resulting from crushing. Less than 10% of the particles that pass the 3/8 inch sieve and are retained on the No. 4 sieve shall be weatherworn particles. Gravel shall not be added to crushed rock.
- B. Gravel shall be defined as particles that show no evidence of mechanical crushing, are fully weatherworn, and are rounded. For pipe bedding, where gravel is specified, crushed rock may be substituted or added.
- C. Where crushed rock or gravel is specified in the bedding details on the plans, the material shall have the following gradations:

Sieve Size	¾ Inch Max Crushed Rock % Passing
2"	
1-1/2"	
1"	100
¾"	90-100
½"	30 – 60
3/8"	0 – 20
No. 4	0 – 5
No. 8	-

2.05 SAND CEMENT SLURRY

- A. Sand cement slurry shall consist of one sack (94 pounds) of portland cement per cubic yard of sand and sufficient moisture for workability.

PART 3 EXECUTION

3.01 PREPARATION

- A. Protection of Existing Utilities and Facilities:
 - 1. The Contractor shall be responsible for the care and protection of all existing sewer pipelines, water pipelines, gas mains, storm drains, culverts, or other facilities and structures that may be encountered in or near the area of work.
 - 2. It shall be the duty of the Contractor to notify each agency of jurisdiction and make arrangements for locating each agency's facilities prior to beginning construction.
 - 3. In the event of damage to any existing facilities during the progress of the work due to the failure of the Contractor to exercise the proper precautions, the Contractor shall be responsible for the cost of all repairs and protection to said facilities. The Contractor's work may be stopped until repair operations are complete

- B. Protection of Landscaping
 - 1. The Contractor shall be responsible for the protection of all the trees, shrubs, fences, and other landscape items adjacent to or within the work area, unless directed otherwise on the plans. In the event of damage to landscape items, the Contractor shall replace the damaged items in a manner satisfactory to the District.

- C. Clearing and Grubbing
 - 1. With acceptance by the District and jurisdictional authority, areas where work is to be performed shall be cleared of all trees, shrubs, rubbish, and other objectionable material of any kind which, if left in place, would interfere with the proper performance or completion of the contemplated work, would impair its subsequent use, or would form obstructions therein.
 - 2. Organic material from clearing and grubbing operations will not be incorporated in the trench backfill.
 - 3. Organic material from clearing and grubbing operations will be disposed of at a proper waste disposal facility.

- D. Sidewalk, Pavement, and Curb Removal
 - 1. Saw cut bituminous or concrete pavements regardless of their thickness, and curbs and sidewalks prior to excavation in accordance with the requirements of the city, or agency having jurisdiction. Curbs and sidewalks, that are damaged in the course of construction, are to be cut and removed from joint to joint.
 - 2. Haul removed pavement and concrete materials from the site, to a proper disposal facility. These materials are not permitted for use as trench backfill. The Contractor shall obtain a haul route permit from the city(s), county, or other agencies having jurisdiction.

3.02 DE-WATERING

- A. Provide and maintain means and devices to continuously remove and properly dispose of all water entering the excavations or other parts of the work during excavation and backfill operations.

MOULTON NIGUEL WATER DISTRICT

- B. De-watering shall be done by methods that will ensure a dry excavation and preservation of the final lines and grades of the bottoms of excavations.
- C. De-watering methods may include well points, sump points, suitable rock or gravel wrapped in filter fabric and placed below the required bedding for drainage and pumping, temporary pipelines, and other means, all subject to the acceptance by the District.
- D. De-watering shall commence when groundwater is first encountered and shall be continuous until such times as water can be allowed to rise. No concrete shall be poured in water, nor shall water be allowed to rise around the concrete or mortar until it has set at least eight hours.
- E. Provide the District with 48-hour notice prior to dewatering operations.
- F. Disposal of Water:
 - 1. Disposal of the water shall comply with SWPPP's of City or other agency having jurisdiction, and shall be done in a manner to prevent damage to adjacent property and pipe trenches.
 - 2. Water shall be discharged in accordance with the requirements of the District's NPDES permit. Reporting shall conform to the requirements of the District's NPDES permit. A copy of the District's permit is available from the District.
 - 3. In no event shall the wastewater system be used as a drain for de-watering except with prior acceptance from the District, securing of a special discharge permit from SOCWA, and with District personnel present during the de-watering operations

3.03 ACCESS

- A. Unobstructed access must be provided to all driveways, water valves, hydrants, or other property or facilities that require use.
- B. Barriers shall be placed at each end of all excavations and at such places as may be necessary along excavations to warn all pedestrians and vehicular traffic of such excavations. Lights shall also be placed along excavations from sunset each day to sunrise of the next day until such excavation is entirely refilled.

3.04 TRENCHING

- A. Trench Depth: Excavation for pipe, fittings, and appurtenances shall be open trench to the depth and in the direction necessary for the proper installation of the facilities as shown on the plans.
- B. Trench Width: Excavation and trenching shall be true to line so that a clear space of not more than 8 inches or less than 6 inches in width is provided on each side of the largest outside diameter of the pipe in place measured at a point 12 inches above the top of the pipe. For the purpose of this article, the largest outside diameter shall be the outside diameter of the bell on bell and spigot pipe, or the pipe collar.
- C. Trench Opening:

MOULTON NIGUEL WATER DISTRICT

1. The maximum allowable length of open trench shall be the distance necessary to accommodate the amount of pipe installed in a single day. Within developed areas, the length of open trench may be restricted as determined by the encroachment permit from the city or the agency having jurisdiction.
2. No trench or excavation shall remain open during non-working hours. The trench or excavation shall be covered with non-skid steel plates, tack welded together, spiked in place, or secured with temporary A.C. pavement around the edges, or backfilled or as otherwise required per the City having jurisdiction.

D. Grade:

1. Excavate the trench to the lines and grades shown on the drawings with allowance for pipe thickness and for pipe base or special bedding.
2. The trench bottom shall be graded to provide a smooth, firm, and stable foundation that is free from rocks and other obstructions. Grade shall be in accordance with plans. Pipes shall be surveyed prior to backfilling to confirm grade.

E. Foundation Stabilization:

1. Whenever the trench bottom does not afford a sufficiently solid and stable base to support the pipe or appurtenances, the Contractor shall excavate to a depth below the design trench bottom, as directed by the District, and the trench bottom shall be backfilled with 3/4-inch rock and compacted to provide uniform support and a firm foundation.
2. Where rock is encountered, it shall be removed to a depth at least 6 inches below grade and the trench shall be backfilled with 3/4-inch crushed rock to provide a compacted foundation cushion.
3. If excessively wet, soft, spongy, unstable, or similarly unsuitable material is encountered at the surface upon which the bedding material is to be placed, the unsuitable material shall be removed to a depth as determined in the field by the District and replaced by crushed rock.

F. Over-Excavation:

1. Over-excavate below subgrade per requirements of geotechnical report.
2. Inadvertent Over-Excavation
 - a. Where excavation is inadvertently carried below design depths, suitable provision shall be made by the Contractor to adjust construction, as directed by the District, to meet requirements incurred by the deeper excavation.
 - b. Native backfill will not be permitted to correct over-excavation beneath structures.
 - c. Over-excavation shall be corrected by backfilling with ¾" crushed rock or concrete, as directed by the District.

G. Trenchless Construction:

1. Tunneling will not be permitted.
2. The use of a jack and bore or hydraulic ram may be employed if accepted by the District.

3.05 SHEETING, SHORING, AND BRACING

- A. Design and install bracing and shoring system in conformance with the rules, orders, and regulations of the Cal/OSHA Sub-chapter 4, Article 6.
- B. For any excavation in excess of 5-feet deep, design of sheeting, shoring, bracing, or side slopes shall be performed by a registered Civil Engineer.
- C. Sufficient geotechnical data shall be obtained to provide safe design.
- D. Excavations shall be braced, sheeted, and supported so that they will be safe, such that the walls of the excavation will not slide or settle and all existing improvements of any kind, either on public or private property, will be fully protected from damage. Methods of support or side slopes shall be selected to provide sufficient clearance for public traffic safety and convenience.
- E. The sheeting, shoring, and bracing shall be arranged so as not to place any stress on portions of the completed work.
- F. Carefully remove sheeting, shoring, bracing, and timbering to prevent the caving or collapse of the excavation faces being supported.

3.06 STOCKPILING AND DISPOSAL OF EXCAVATED MATERIAL

- A. All excavated material shall not be stockpiled in a manner that will create an unsafe work area or obstruct sidewalks or driveways. Gutters shall be kept clear or other satisfactory measures shall be taken to maintain the street or other drainage.
- B. In confined work areas, the Contractor may be required to stockpile the excavated material off-site, as determined by the project permits.
- C. Surplus/Excess Excavated Material:
 - 1. The Contractor shall make the necessary arrangements for and shall remove and dispose of all excess excavated material unless indicated differently in the special provisions for any job.
 - 2. It is the intent of these specifications that all surplus material not required for backfill or fill shall be properly disposed of by the Contractor at his expense at a proper disposal site.
 - 3. No excavated material shall be deposited on private property unless written permission from the owner thereof is secured by the Contractor. Before the District will accept the work, the Contractor shall file a written release signed by all property owners with whom they have entered into agreements for disposing excess excavated material, absolving the District from any liability connected therewith.
 - 4. The Contractor shall obtain a haul route permit from the city or agency having jurisdiction.

3.07 PLACING PIPE BEDDING

- A. Place the thickness of pipe bedding material over the full width of trench necessary to produce the required bedding thickness when the material is compacted to the specified relative density. Grade the top of the pipe bedding ahead of the pipe to provide firm, uniform support along the full length of pipe.

- B. Excavate bell holes at each joint to permit assembly and inspection of the entire joint.
- C. Place mounds to support pipe (DIP only):
 - 1. As an alternate to placing continuous imported sand pipe bedding material, the ductile iron pipe may be supported on mounds of imported sand.
 - 2. The mounds shall be of imported sand and extend the full trench width. The mounds shall provide a minimum of 6 inches of contact with the pipe.
 - 3. The pipe shall be supported to maintain its design line and grade.
 - 4. The mounds shall be located 2½ feet from the bell/spigot of the pipe.

3.08 BACKFILLING WITHIN PIPE ZONE

- A. Backfill per the detailed piping specification for the particular type of pipe and per the following.
- B. After pipe has been installed in the trench, place pipe zone material simultaneously on both sides of the pipe, keeping the level of backfill the same on each side. Carefully place the material around the pipe so that the pipe barrel is completely supported and that no voids or uncompacted areas are left beneath the pipe. Use particular care in placing material on the underside of the pipe to prevent lateral movement during subsequent backfilling.
- C. When backfill is to be placed before 7-day concrete strength tests have been conducted on concrete arches for VCP sewers or thrust blocks, the concrete shall have achieved 50 percent of the specified minimum 28-day strength. An additional test cylinder shall be made for this test.
- D. Compact material placed within 12 inches of the outer surface of the pipe by hand tamping only.
- E. Removal and replacement of any trench and backfill material which does not meet the specifications shall be the Contractor's responsibility.

3.09 COMPACTION REQUIREMENTS

- A. The Developer will engage the services of a qualified soils engineering firm to determine the relative compaction of the trench backfill. On capital projects, the District will engage the services of a qualified soils engineering firm to determine the relative compaction of the trench backfill.
- B. If the backfill fails to meet the specified relative compaction requirements, the Contractor shall rework the backfill until the requirements are met. The Contractor shall make all necessary excavations for density tests as directed by the District. Orange County Public Works, the city having jurisdiction, or Caltrans compaction requirements shall prevail in all public roads. The Developer or Contractor will be responsible for the cost of all additional compaction tests in the reworked areas.
- C. Compaction tests shall be performed at random depths and at 100-foot intervals unless otherwise directed by the District.
- D. Unless otherwise shown on the drawings or otherwise described in the specifications for the particular type of pipe installed, relative compaction in pipe trenches shall be as described below:

1. Pipe zone and pipe base: 90% relative compaction
2. Rock refill for over-excavation: 90% relative density
3. Above pipe zone: Per requirements of city or agency having jurisdiction

3.10 RESTORATION

- A. Replace bituminous and concrete pavement, curbs, and sidewalks damaged or removed during construction in accordance with the requirements of the city or the agency having jurisdiction.

3.11 SLOPE PROTECTION

- A. Construct pipe slope anchors as shown on the Drawings wherever the profile of the ground surface above the main exceeds 20-percent, or where shown on the Drawings.
- B. Place 4-inch thick layer of cemented rubble and concrete surface slope protection wherever the profile of the ground surface above the main exceeds 20-percent, or where shown on the Drawings.
- C. A reinforced concrete encasement may be used as directed by the District. The encasement shall extend to within 1-foot of the ground surface and to within 1-foot of the toe of slope in which the pipe is constructed.

3.12 FIELD QUALITY CONTROL

- A. All trenching excavation, backfill, and compaction, shall be performed under inspection by a California licensed Geotechnical Engineer.

B. Testing for Compaction

1. Determine the density of soil in place by the use of a sand cone (ASTM D1556), drive tube (ASTM D2937), or nuclear tester (ASTM D6938).
2. Determine laboratory moisture-density relations of existing soils by ASTM D1557.
3. Determine the relative density of cohesionless soils by ASTM D4254.
4. Sample backfill materials by ASTM D75.
5. Express "relative compaction" as the ratio, expressed as a percentage, of the in place dry density to the laboratory maximum dry density.
6. Compaction shall be deemed to comply with the specifications when no test falls below the specified relative compaction.
7. The Developer will secure the services of a soils tester and pay the costs of all compaction testing. On capital projects, the District will secure the service of a soils tester and pay the cost of initial testing. The Contractor will be responsible for the cost of all retests in failed areas. Test results will be furnished by the District.
8. Compaction shall be deemed to comply with the specifications when none of the tests fall below the specified relative compaction. When tests are conducted by the District, the Contractor shall notify the District 24-hours in advance of when backfill lifts are ready for testing, and shall pay the costs of any retesting of work not conforming to the specifications.
9. Unless noted otherwise, compaction tests shall be performed at random depths at 200-foot intervals, and as directed by the District.
10. All imported or native materials shall be tested before the start of compaction operations to determine the moisture density relationship for materials with cohesive components, and the maximum density for cohesionless materials. Variations in imported or native earth materials may require a number of base curves of the moisture-density relationship.

END OF SECTION

SECTION 03300

CONCRETE

PART 1 GENERAL

1.01 SECTION INCLUDES

- A. Cast-in-place concrete

1.02 REFERENCED STANDARDS

- A. American Concrete Institute (ACI)
 - 1. ACI 117: Standard Tolerances for Concrete Construction and Materials
 - 2. ACI 211.1: Standard Practice for Selecting Proportions for Normal, Heavyweight, and Mass Concrete
 - 3. ACI 214: Recommended Practice for Evaluation of Strength Test Results of Concrete
 - 4. ACI 301: Specifications for Structural Concrete
 - 5. ACI 304R: Guide for Measuring, Mixing, Transporting, and Placing Concrete
 - 6. ACI 305R: Guide to Hot Weather Concreting
 - 7. ACI 306: Guide to Cold Weather Concreting
 - 8. ACI 308R: Guide to External Curing of Concrete
 - 9. ACI 309: Consolidation of Concrete
 - 10. ACI 315: Details and Detailing of Concrete Reinforcement
 - 11. ACI 318: Building Code Requirements for Reinforced Concrete
 - 12. ACI 347R: Guide to Formwork for Concrete
- B. American Lumber Standard Committee:
 - 1. PS 1: U.S. Product Standard for Concrete Forms, Class I
 - 2. PS 20: American Softwood Lumber Standard
- C. ASTM International (ASTM)
 - 1. ASTM A1064: Standard Specification for Carbon-Steel Wire and Welded Wire Reinforcement, Plain and Deformed, for Concrete
 - 2. ASTM C31: Practice for Making and Curing Concrete Test Specimens in the Field
 - 3. ASTM C33: Standard Specification for Concrete Aggregates
 - 4. ASTM C39: Test Method for Compressive Strength of Cylindrical Concrete Specimens
 - 5. ASTM C94: Standard Specification for Ready-Mixed Concrete
 - 6. ASTM C109: Standard Test Method for Compressive Strength of Hydraulic Cement Mortars

7. ASTM C143: Test Method for Slump of Hydraulic Cement Concrete
8. ASTM C150: Standard Specification for Portland Cement
9. ASTM C171: Standard Specification for Sheet Materials for Curing Concrete
10. ASTM C309: Specifications for Liquid Membrane Forming Compounds for Curing Concrete
11. ASTM C494: Specification for Chemical Admixtures for Concrete
12. ASTM C579: Standard Test Methods for Compressive Strength of Chemical-Resistant Mortars, Grouts, Monolithic Surfacing, and Polymer Concretes
13. ASTM A615: Standard Specification for Deformed and Plain Carbon-Steel Bars for Concrete Reinforcement
14. ASTM C827: Standard Test Method for Change in Height at Early Ages of Cylindrical Specimens of Cementitious Mixtures
15. ASTM C881: Standard Specification for Epoxy-Resin-Base Bonding Systems for Concrete
16. ASTM C920: Specification for Elastomeric Joint Sealants
17. ASTM C1077: Practice for Laboratories Testing Concrete and Concrete Aggregates for use in Construction & Criteria for Laboratory Evaluation
18. ASTM C1107: Standard Specification for Packaged Dry, Hydraulic-Cement Grout
19. ASTM D638: Test Method for Tensile Properties of Plastic
20. ASTM D747: Test Method for Apparent Bending Modulus of Plastics by Means of a Cantilever Beam

D. American Welding Society:

1. AWS D1.4: Structural Welding Code – Reinforcing Steel

E. U.S. Army Corps of Engineers (ACOE) Specifications:

1. CRD-C572: PVC Waterstop

F. Concrete Reinforcing Steel Institute (CRSI)

1. Manual of Standard Practice

1.03 SUBMITTALS

- A. General: Submit all information for all products and materials.
- B. Formwork: Calculations and drawings

C. Reinforcing:

1. Product cutsheets
2. Materials of construction
3. Shop drawings:
 - a. Details of reinforcement steel for fabrication and erection shall conform to ACI 315 and the requirements indicated.
 - b. The shop bending diagrams shall show the actual lengths of bars, to the nearest inch, measured to the intersection of the extensions (tangents for bars of circular cross section) of the outside surface.
 - c. The shop drawings shall include bar placement diagrams which clearly indicate the dimensions of each bar splice.
4. Welding procedures: The Contractor shall submit a written welding procedure for each type of weld for each size of bar which is to be spliced by welding; a mere statement that AWS procedures will be followed will not be acceptable.

D. Concrete:

1. Mix design: Sign and seal mix designs by licensed civil or structural engineer, registered in the State of California. Mix design shall include:
 - a. Indicate proposed mix design complies with requirements of ACI 301.
 - b. Indicate proposed mix design complies with requirements of ACI 318.
 - c. Provide certificate that cement used complies with ASTM C150 and these specifications.
 - d. Provide delivery tickets for ready-mix concrete or weighmasters certificate per ASTM C94, including weights of cement and each size aggregate and amount of water added at the plant and record of pours.
 - 1) Record the amount of water added on the job on the delivery ticket.
 - 2) Water added at the plant shall account for the moisture in both coarse and fine aggregate.
 - e. Provide plant qualification showing conformance with requirements of the Check List for Certification of Ready Mixed Concrete Production facilities of the National Ready Mixed Concrete Association and ASTM C94.

E. Curing: Materials and methods

1.04 DELIVERY, STORAGE, AND HANDLING

- A. Deliver reinforcing steel to the site bundled and tagged with identifying tags.

PART 2 PRODUCTS

2.01 FORMWORK

- A. Construction:
 - 1. Comply with requirements of ACI 347R
 - 2. Forms shall be accurately constructed of clean lumber and shall be of sufficient strength and rigidity to hold the concrete and to withstand the necessary pressure and tamping without deflection from the prescribed lines.
 - 3. The surface of forms against which concrete is placed shall be smooth and free from irregularities, dents, sags, or holes. The surface shall leave uniform form marks conforming to the general lines of the structure.

- B. Form Materials:
 - 1. Lumber shall be Douglas Fir or Southern Yellow Pine, construction grade or better, in conformance with U.S. Product Standard PS 20.
 - 2. Plywood for concrete formwork shall be new, waterproof, synthetic resin bonded, exterior type Douglas Fir or Southern Yellow Pine plywood manufactured especially for concrete formwork and shall conform to the requirements of PS 1 for Concrete Forms, Class I, and shall be edge sealed.

- C. Form Ties:
 - 1. Form ties with integral water stops shall be provided with a plastic code or other suitable means for forming a conical hole to insure that the form tie may be broken off back of the face of the concrete.
 - 2. The maximum diameter of removable cones for rod ties, or of other removable-tie fasteners having a circular cross-section, shall exceed 1-1/2 inches and all such fasteners shall be such as to leave holes of regular shape for reaming.

2.02 REINFORCING STEEL

- A. Reinforcing Steel: Billet steel conforming ASTM A615, Grade 60 (60,000 psi)

- B. Steel Welded Wire Reinforcement (WWR): Galvanized, plain type, ASTM A1064

- C. Fabrication:
 - 1. Conform to requirements of the Manual of Standard Practice, published by the Concrete Reinforcing Steel Institute.
 - 2. Bend reinforcing steel cold.
 - 3. Fabricate to meet tolerances of ACI 117.

- D. Tie wire: 16 gage minimum, black, soft annealed

E. Supports:

1. Bar supports: Meet the requirements of the CRSI Manual of Standard Practice, Chapter 3, including special requirements for support of epoxy coated reinforcing bars.
 - a. Wire bar supports shall be CRSI Class 1 for maximum protection with a 1/8-inch minimum thickness of plastic coating which extends at least 1/2-inch from the concrete surface. Plastic shall be gray in color.
2. Concrete blocks (dobies): Used to support and position reinforcement steel, shall have the same or higher compressive strength as specified for the concrete in which it is located. Wire ties shall be embedded in concrete block bar supports.

F. Mechanical Couplers

1. Provided where indicated and where accepted by the District
2. Tensile strength shall exceed 125-percent of the yield strength of the reinforcement bars being spliced at each splice.
3. The reinforcement steel and coupler used shall be compatible for obtaining the required strength of the connection.
4. Straight thread type couplers shall require the use of the next larger size reinforcing bar or shall be used with reinforcing bars with specially forged ends which provide upset threads which do not decrease the basic cross section of the bar.

G. Welded Splices

1. Provided where indicated and where accepted by the District.
2. Tensile strength shall exceed 125-percent of the yield strength of the reinforcement bars which are connected.
3. All materials required to conform the welded splices to the requirements of AWS D1.4 shall be provided.

2.03 PORTLAND CEMENT CONCRETE MATERIALS

A. Cement:

1. ASTM C150, Type V - Sulfate Resistant Portland type
2. Acquire cement for entire project from same source.
3. The content of tricalcium aluminate shall not exceed 6-percent and the content of alkalis shall not exceed 0.6-percent.

B. Aggregates:

1. Conform to ASTM C33
2. Acquire aggregates for entire project from same source
3. Free from any substances that will react with the cement alkalis

- 4. Coarse aggregate
 - a. Clean, hard, durable gravel, crushed rock, or combination thereof
 - b. Maximum size: 3/4-inch
 - 5. Fine aggregates
 - a. Sand or a combination of natural and manufactured sand that are hard and durable
 - b. Gradation of fine aggregate shall conform to ASTM C33 with 15 to 30-percent passing the number 50 screen and 5 to 10-percent passing the number 100 screen.
- C. Water: Clean and not detrimental to concrete
- D. Admixtures:
- 1. Do not use chemicals that will result in soluble chloride ions in excess of 0.1 percent by weight of cement.
 - 2. Water Reducing Admixture: ASTM C494 Type A
 - 3. Set Retarding Admixture: ASTM C494 Type B or D
 - 4. Set Accelerating Admixture: ASTM C494 Type C or E

2.04 CONCRETE DESIGN REQUIREMENTS

- A. Establish required average strength for concrete on the basis of trial mixtures, as specified in ACI 301.
- B. Add acceptable admixtures as recommended in ACI 211.1 and at rates recommended or required by manufacturer.
- C. At the Contractor’s option, ready mix concrete may be used meeting the requirements of ASTM C94.
- D. Concrete classes called out on the Drawings shall conform to the following:

Class	Type of work, unless indicated otherwise	28-Day Compressive Strength (in psi)	Slump (inches)	Min. Cement Content (in lbs. Per C.Y.)
A	Where shown on the Drawings	4,000	4	650 (7 sacks)
B	Thrust blocks, anchors, pipe encasement, manhole bases, and pads	3,250	5	560 (6 sacks)
C	Guard posts	2,500	5	500 (5.5 sacks)

2.05 CONCRETE ACCESSORIES

- A. Anchor bolts:
 - 1. Type 316 stainless steel
 - 2. Possess a current ICC Evaluation Service report
- B. Non-Shrink Cementitious Grout: Premixed compound consisting of non-metallic aggregate, cement, water reducing, and plasticizing agents
 - 1. Grout: Comply with ASTM C1107
 - 2. Height Change, Plastic State; when tested according to ASTM C827
 - a. Maximum: Plus 4 percent
 - b. Minimum: Plus 1 percent
 - 3. Minimum Compressive Strength at 48 Hours, ASTM C109: 2,000 pounds per square inch
 - 4. Minimum Compressive Strength at 28 Days, ASTM C109: 7,000 pounds per square inch
- C. Non-Shrink Epoxy Grout: Moisture-insensitive, two-part; consisting of epoxy resin, non-metallic aggregate, and activator
 - 1. Composition: High solids content material exhibiting positive expansion when tested in accordance with ASTM C827
 - a. Maximum Height Change: Plus 4 percent
 - b. Minimum Height Change: Plus 1 percent
 - 2. Minimum Compressive Strength at 7 days, ASTM C579: 12,000 pounds per square inch
- D. Joint Sealant:
 - 1. Elastomeric Sealant complying with requirements of ASTM C920
 - 2. Plastic Foam Joint-Fillers: Preformed, compressible, resilient, non-waxing, non-extruding strips of plastic foam of either flexible open cell polyurethane foam or non-gassing closed-cell polyethylene foam, subject to sealant manufacturer's approval
 - 3. Bond-breaker tape: designed to prevent bond between sealant and joint filler
- E. Concrete bonding agent:
 - 1. Epoxy Bonding System
 - 2. Comply with ASTM C881
- F. Dampproofing agent: Asphalt emulsion
- G. Waterstops:
 - 1. Extruded PVC, complying with ACOE CRD-C 572.
 - 2. Ribbed with centerbulb with minimum 3/8-inch thickness
 - 3. Prefabricated joint fittings shall be used at all intersections of the ribbed-type waterstops.

4. Tensile strength: 1,400 psi per ASTM D638, Type IV
5. Stiffness in Flexure: 400 psi per ASTM D747

PART 3 EXECUTION

3.01 FORMWORK INSTALLATION

- A. Design and install formwork in compliance with requirements of ACI 347R.
- B. The Contractor shall notify the District a minimum of one working day before the placement of concrete to enable the District to check the form lines, grades, and other required items for acceptance before placement of concrete.
- C. Unless otherwise indicated on the plans, all exposed sharp edges shall be chamfered with at least 3/4 - by 3/4 inch triangular fillets.
- D. Before placing concrete, the form surface shall be clean and coated with form oil of high penetrating qualities.
- E. All embedded bolts, dowels, anchors, and other embedded items shall be held correctly in place in the forms before concrete is placed.
- F. Ties:
 1. Holes left by the removal of form tie cones shall be reamed with suitable toothed reamers so as to leave the surface of the holes clean and rough before being filled with mortar. Ties shall not be removed in such manner as to leave a hole extending through the interior of the concrete members.
 2. After the taper tie is removed, the hole shall be thoroughly cleaned and roughened for bond. A precast neoprene or polyurethane tapered plug shall be located at the wall centerline. The hole shall be completely filled with non-shrink grout for water bearing and below-grade walls. The hole shall be completely filled with non-shrink or regular cement grout for above-grade walls which are dry on both sides.
- G. Forms shall be maintained at all times in good condition, particularly as to size, shape, strength, rigidity, tightness, and smoothness of surface.
- H. False Work: The Contractor shall be responsible for the design, engineering, construction, maintenance and safety of all false work, including staging, walkways, forms, ladders, and similar appurtenances, which shall equal or exceed the applicable requirements of the provisions of the OSHA Safety and Health Standards for Construction, and the requirements of the California Division of Industrial Safety.

3.02 REINFORCEMENT

- A. General:
 1. Place reinforcing steel in accordance with CRSI Manual of Standard Practice.
 2. All reinforcing steel shall be of the required sizes and shapes and placed where shown on the drawings or prescribed by the District.

3. Do not straighten or rebend reinforcing steel in a manner that will injure the material. Do not use bars with bends not shown on the drawings.
4. All bars shall be free from rust, scale, oil, or any other coating which would reduce or destroy the bond between concrete and steel.
5. All reinforcing steel and wire mesh shall be completely encased in concrete.
6. Place additional reinforcement around the pipe or opening as indicated in the drawings.
7. Position reinforcement steel in accordance with the drawings and secure by using annealed wire ties or clips at intersections and support by concrete or metal supports, spacers, or metal hangers. Do not place metal clips or supports in contact with the forms. Bend tie wires away from the forms in order to provide the specified concrete coverage. Bars additional to those shown on the drawings, which may be found necessary or desirable by the Contractor for the purpose of securing reinforcement in position, shall be provided and paid for by the Contractor.
8. Secure reinforcing dowels in place prior to placing concrete. Do not press dowels into the concrete after the concrete has been placed.
9. Place reinforcement a minimum of 2 inches clear of any metal pipe or fittings.
10. Minimum lap for all reinforcement shall be 20 bar diameters.

B. Wire Mesh

1. Wire mesh reinforcement is to be rolled flat before being placed in the form. Support and tie wire mesh to prevent movement during concrete placement.
2. Extend welded wire fabric to within 2 inches of the edges of the slab. Lap splices at least 1-1/2 courses of the fabric and a minimum of 6 inches. Tie laps and splices securely at ends and at least every 24 inches with 16 gage black annealed steel wire. Pull the fabric into position as the concrete is placed by means of hooks, and work concrete under the steel to ensure that it is at the proper distance above the bottom of the slab.

C. Ties: The reinforcement shall be so secured in position that it will not be displaced during the placement of concrete.

D. Limitations on the use of the bar support materials shall be as follows:

1. Concrete Dobies: Permitted at all locations except where architectural finish is required.
2. Wire Bar Supports: Permitted only at slabs over dry areas, interior dry wall surfaces and exterior wall surfaces.
3. Plastic Bar Supports: Permitted at all locations except on grade.

E. Splices

1. General: Splicing shall be in accordance with ACI 318, unless otherwise noted on Drawings.
2. Vertical Bars: Except as specifically detailed or otherwise indicated, splicing of vertical bars in concrete is not permitted, except at the indicated or approved horizontal construction joints or as otherwise specifically detailed.
3. Horizontal Bars: Except as specifically detailed or otherwise indicated, splicing of horizontal bars in concrete is not permitted.

4. Mechanical Couplers: Unless otherwise indicated or accepted by the District, use of mechanical couplers is not permitted.
5. Welding: Except as specifically detailed or otherwise indicated, welding of reinforcing bars is not permitted.

3.03 DRILLED EPOXY DOWELS

- A. The hole diameter shall be as recommended by the epoxy manufacturer but shall be no larger than 0.25 inch greater than the diameter of the outer surface of the reinforcing bar deformations.
- B. The depth of the hole shall be as recommended by the epoxy manufacturer to fully develop the bar but shall not be less than 12 bar diameters, unless noted otherwise.
- C. The location of holes to be drilled shall be adjusted to avoid drilling through or nicking any existing reinforcing bars.
- D. Install epoxy per manufacturer's recommendations.

3.04 MIXING AND PLACING CONCRETE

- A. Concrete, either commercial or on-site ready mix or batch mixed, shall be placed in the forms before taking its initial set.
- B. No concrete shall be placed in water except with permission of the District.
- C. As the concrete is placed in the forms, or in excavations to be filled with concrete, it shall be thoroughly settled and compacted throughout the entire layer by internal vibration and tamping bars.
- D. All concrete surfaces upon which or against which the concrete is to be placed, and to which new concrete is to adhere, shall be roughened, thoroughly cleaned, wet, and grouted before the concrete is deposited.
- E. Maintain records of concrete placement. Record date, location, quantity, air temperature, and test samples taken.
- F. Ensure reinforcement, inserts, and formed construction joint devices will not be disturbed during concrete placement.
- G. Place concrete continuously without construction (cold) joints wherever possible.
 1. Where construction joints are necessary, before next placement prepare joint surface by removing laitance and exposing the sand and sound surface mortar, by sandblasting or high-pressure water jetting.
 2. Provide construction joints at 25-foot maximum spacing, unless noted otherwise.
- H. Cold Weather Placement:
 1. Placement of concrete shall conform to ACI 306 – Standard Specification for Cold Weather Concreting and the following.

2. Remove all snow, ice and frost from the surfaces, including reinforcement, against which concrete is to be placed. Before beginning concrete placement, thaw the subgrade to a minimum depth of 6 inches. All reinforcement and embedded items shall be warmed to above 32 degrees F before concrete placement.
3. Concrete ingredients shall not be heated to a temperature higher than that necessary to keep the temperature of the mixed concrete, as placed, from falling below the specified minimum temperature.
4. Maintain the concrete temperature above 50 degrees F for at least 3 days after placement.

I. Hot Weather Placement:

1. Placement of concrete shall conform to ACI 305R – Hot Weather Concreting, and the following.
2. When the temperature of the concrete is 85 degrees F or above, the time between the introduction of the cement to the aggregates and discharged shall not exceed 45 minutes.
3. If concrete is placed when the weather is such that the temperature of the concrete would exceed 90 degrees F, the Contractor shall employ effective means, such as pre-cooling aggregates and mixing water using ice or placing at night, as necessary to maintain the temperature of the concrete, as it is placed, below 90 degrees F. The Contractor shall be entitled to no additional compensation on account of foregoing requirements.
4. Only set retarding admixture shall be used in concrete when air temperature is expected to be consistently over 80 degrees F.
5. The maximum temperature of concrete shall not exceed 90 degrees F immediately before placement.
6. From the initial placement to the curing state, concrete shall be protected from the adverse effect of high temperature, low humidity and wind.

3.05 PUMPING OF CONCRETE

- A. General: If the pumped concrete does not produce satisfactory end results, discontinue the pumping operation and proceed with the placing of concrete using conventional methods.
- B. Pumping Equipment: The pumping equipment must have two cylinders and be designed to operate with one cylinder only in case the other is not functioning. In lieu of this requirement, the Contractor may have a standby pump on the site during pumping.
- C. The minimum diameter of the hose (conduits) shall be in accordance with ACI 304R.
- D. Pumping equipment and hoses (conduits) that are not functioning properly shall be replaced.
- E. Aluminum conduits for conveying the concrete shall not be permitted.
- F. Field Control: Concrete samples for slump, air content and test cylinders will be taken at the placement (discharge) end of the line.

3.06 TAMPING AND VIBRATING

- A. As concrete is placed in the forms or in excavations, it shall be thoroughly settled and compacted throughout the entire depth of the layer which is being consolidated, into a dense homogeneous mass, filling all corners and bringing only a slight excess of water to the exposed surface of concrete during placement. Vibrators shall be Group 3 (per ACI 309) high speed power vibrators (8,000 to 12,000 rpm) of an immersion type in sufficient number and with (at least one) standby unit(s) as required. Group 2 vibrators may be used only at specific locations when accepted by the District.

- B. Care shall be used in placing concrete around waterstops. The concrete shall be carefully worked by rodding and vibrating to make sure that all air and rock pockets have been eliminated. Where flat-strip type waterstops are placed horizontally, the concrete shall be worked under the waterstops by hand, making sure that all air and rock pockets have been eliminated. Concrete surrounding the waterstops shall be given additional vibration, over and above that used for adjacent concrete placement to assure complete embedment of the waterstops in the concrete.

- C. Concrete in walls shall be internally vibrated and at the same time rammed, stirred, or worked with suitable appliances, tamping bars, shovels, or forked tools until it completely fills the forms or excavations and closes snugly against all surfaces. Subsequent layers of concrete shall not be placed until the layers previously placed have been worked thoroughly as required, to accomplish the results herein specified within 15 minutes after concrete of the prescribed consistency is placed in the forms. The vibrating head shall be kept from contact with the surfaces of the forms. Care shall be taken not to vibrate concrete excessively or to work it in any manner that causes segregation of its constituents.

3.07 CONCRETE FINISHING

- A. Surfaces shall be free from fins, bulges, ridges, offsets, honeycombing or roughness of any kind, and shall present a finished, smooth, continuous hard surface.
- B. Surface holes larger than 1/2 inch in diameter or deeper than 1/4 inch are defined as surface defects in basins and exposed walls.
- C. Immediately upon the removal of forms, all voids shall be neatly filled with cement mortar.
- D. The surfaces of concrete to be permanently exposed to view must be smooth, free from projections, and thoroughly filled with mortar.
- E. Exposed surfaces of concrete not finished against forms, such as horizontal or sloping surfaces, shall be screened to a uniform surface and worked with suitable tools to a smooth mortar finish.

3.08 PROTECTION AND CURING OF CONCRETE

- A. Comply with requirements of ACI 308R. Immediately after placement, protect concrete from premature drying, excessively hot or cold temperatures, and mechanical injury.
- B. Exposed surfaces of new concrete shall be protected from the direct rays of the sun and from frost by being kept damp for at least two weeks after the concrete has been placed, or by using accelerant / retardant compound process or approved equal accepted by the District.
- C. Maintain concrete with minimal moisture loss at relatively constant temperature for period necessary for hydration of cement and hardening of concrete.
- D. Formed Surfaces: Cure by moist curing with forms in place for full curing period.
- E. Surfaces Not in Contact with Forms:
 - 1. Initial Curing: Start as soon as free water has disappeared and before surface is dry. Keep continuously moist for not less than three days by water ponding, water-saturated sand, water-fog spray, or saturated burlap.
 - 2. Final Curing: Begin after initial curing but before surface is dry.
 - a. Moisture-Retaining Sheet: Lap strips not less than 3 inches and seal with waterproof tape or adhesive; secure at edges.
 - b. Curing Compound: Apply in two coats at right angles, using application rate recommended by manufacturer.

3.09 FORMWORK REMOVAL

- A. Carefully remove formwork to avoid injury to the concrete.
- B. No heavy loading on green concrete will be permitted.
- C. Do not backfill against walls until the top slab is in place and all concrete has obtained compressive strength equal to the specified 28-day compressive strength.

- D. Formwork removal periods:
 - 1. General: Remove once 28-day compressive strength is achieved, except as noted otherwise.
 - 2. Curbs: Sufficient time to hold shape
 - 3. Non-load bearing walls: 16 hours
- E. Forms may be reused only if in good condition and only if acceptable to the District.

3.10 FIELD QUALITY CONTROL

- A. Field Testing: Perform field testing on all Class A concrete as follows:
 - 1. Tests on component materials and for compressive strength and shrinkage of concrete will be performed as specified herein. Test for determining slump will be in accordance with requirements of ASTM C143.
 - 2. The cost of all laboratory tests requested by the District on cement, aggregates and concrete will be borne by the District. However, the Contractor will be charged for the cost of any additional tests and investigation on work performed which does not meet the specifications. The laboratory must meet or exceed the requirements of ASTM C1077.
 - 3. The Contractor shall provide assistance to the District in obtaining samples and disposal and clean up of excess material.
 - 4. Field Compression Tests:
 - a. Compression test specimens will be taken during construction from the first placement of each class of concrete specified herein and at intervals thereafter as selected by the District to ensure continued compliance with these specifications. Each set of test specimens will be a minimum of five cylinders.
 - b. Compression test specimens for concrete shall be made in accordance with section 9.2 of ASTM C31. Specimens shall be 6-inch diameter by 12-inch high cylinders.
 - c. Compression tests shall be performed in accordance with ASTM C39. One test cylinder will be tested at 7 days and two at 28 days. The remaining cylinders will be held to verify test results, if needed.
 - 5. Evaluation and Acceptance of Concrete:
 - a. Evaluation and acceptance of the compressive strength of concrete shall be according to the requirements of ACI 318, Chapter 5 "Concrete Quality" and as specified herein.
 - b. A statistical analysis of compression test results will be performed according to the requirements of ACI 214. The standard deviation of the test results shall not exceed 640 psi when ordered at equivalent water content as estimated by slump.
 - c. If any concrete fails to meet these requirements, immediate corrective action shall be taken to increase the compressive strength for all subsequent batches of the type of concrete affected.

MOULTON NIGUEL WATER DISTRICT

- d. When the standard deviation of the test results exceeds 640 psi, the average strength for which the mix is designed shall be increased by an amount necessary to satisfy the statistical requirement that the probability of any test being more than 500 psi below or the average of any three consecutive tests being below the specified compressive strength is 1 in 100. The required average strength shall be calculated by Criterion No. 3 of ACI 214 using the actual standard of deviation.
- e. All concrete which fails to meet the ACI requirements and these specifications is subject to removal and replacement at no additional cost to the District.

B. Tolerances:

- 1. Formwork: Comply with ACI 347
- 2. Concrete:
 - a. Set and maintain concrete forms and perform finishing operations so as to ensure that the completed work is within the tolerances specified herein.
 - b. Surface defects and irregularities are defined as finishes and are to be distinguished from tolerances.
 - c. Tolerance is the specified permissible variation from lines, grades or dimensions shown.
 - d. Where tolerances are not slated in the specifications, permissible deviations will be in accordance with ACI 117.
 - e. The following construction tolerances are hereby established and apply to finished walls and slab unless otherwise shown:

Item	Tolerance
Variation of the constructed linear outline from the established position in plan	In 10 feet: 1/4-inch In 20 feet or more: 1/2-inch
Variation from the level or from the grades shown	In 10 feet: 1/4-inch In 20 feet or more: 1/2-inch
Variation from the plumb	In 10 feet: 1/4-inch In 20 feet or more: 1/2-inch
Variation in the thickness of slabs and walls	Minus 1/4-inch; Plus 1/2-inch
Variation in the locations and sizes of slabs and wall openings	Plus or minus 1/4-inch

END OF SECTION

SECTION 03461

PRECAST REINFORCED CONCRETE MANHOLES

PART 1 GENERAL

1.01 SECTION INCLUDES

- A. Precast reinforced concrete manholes
- B. Manhole bases
- C. Manhole frames and covers

1.02 RELATED REQUIREMENTS

- A. Section 02200, Earthwork
- B. Section 02223, Trenching, Backfilling, and Compacting
- C. Section 03300, Concrete
- D. Section 15043, Testing of Non-Pressure Sewer Pipelines and Manholes

1.03 REFERENCED STANDARDS

- A. American Society of Testing and Materials (ASTM)
 - 1. ASTM A48: Standard Specification for Gray Iron Castings
 - 2. ASTM A536: Standard Specification for Ductile Iron Castings
 - 3. ASTM C31: Standard Practice for Making and Curing Concrete Test Specimens in the Field
 - 4. ASTM C39: Standard Test Method for Compressive Strength of Cylindrical Concrete Specimens
 - 5. ASTM C138: Standard Test Method for Density (Unit Weight), Yield, and Air Content (Gravimetric) of Concrete
 - 6. ASTM C143: Standard Test Method for Slump of Hydraulic-Cement Concrete
 - 7. ASTM C150: Standard Specification for Portland Cement
 - 8. ASTM C173: Standard Test Method for Air Content of Freshly Mixed Concrete by the Volumetric Method
 - 9. ASTM C192: Standard Practice for Making and Curing Concrete Test Specimens in the Laboratory
 - 10. ASTM C231: Standard Test Method for Air Content of Freshly Mixed Concrete by the Pressure Method

11. ASTM C478: Standard Specification for Circular Precast Reinforced Concrete Manhole Sections
 12. ASTM C990: Standard Specification for Joints for Concrete Pipe, Manholes, and Precast Box Sections Using Preformed Flexible Joint Sealants
- B. American Association of State Highway and Transportation Officials (AASHTO)
1. AASHTO M306: Standard Specification for Drainage, Sewer, Utility, and Related Castings
- C. State of California Construction Safety Orders
1. Article 4, Section 1532 "Confined Spaces"

1.04 SUBMITTALS

- A. Design calculations and detailed drawings of component sections signed by a registered California Professional Engineer. Show dimensions and materials of construction by ASTM reference and grade.
- B. Shop drawings of grating, grating frame embeds, covers, and all appurtenances
- C. Shop drawings indicating the installation procedures and dimensions, and the location of all joints or welded strips
- D. Results of testing required per paragraph of this specification entitled "Quality Assurance"
- E. Qualifications of engineer designing the precast concrete structure
- F. Recommendations for inlet and outlet seals, and watertight caulking
- G. Show manhole cover lettering and pattern.

1.05 QUALITY ASSURANCE

- A. Precast concrete producer shall demonstrate adherence to the standards set forth in the National Precast Concrete Association Quality Control Manual.
- B. The precast concrete producer shall have been in the business of producing precast concrete products similar to those specified for a minimum of 5 years. The precast concrete producer shall maintain a permanent quality control department, or retain an independent testing agency on a continuing basis. The agency shall issue a report, certified by a licensed engineer, detailing the ability of the precast concrete producer to produce quality products consistent with industry standards.
- C. The precast concrete producer shall show that the following tests are performed in accordance with the ASTM standards indicated. Tests shall be performed for each 150 cu. yd. of concrete placed, but not less frequently than once per week.
 1. Slump: C143
 2. Compressive Strength: C31, C192, C39

- 3. Air Content (when air-entrained concrete is being used): C231 or C173
 - 4. Unit Weight: C138
- D. The District may place an inspector in the plant when the products covered by this specification are being manufactured.

PART 2 PRODUCTS

2.01 PRECAST CONCRETE MANHOLES

- A. General: Precast reinforced concrete manholes shall comply with ASTM C478, with a minimum wall thickness of 6-inches.
- B. Design Load: Manhole components shall be designed for H-20 highway loads and site soil conditions.
- C. Cement: Type V per ASTM C 150
- D. Manhole Section Configuration: Manholes shall be fabricated only from eccentric taper sections and standard cylinder units of the proper internal diameter.
- E. Manhole Section Dimensions:
 - 1. Unless noted otherwise, minimum internal diameter manhole sections shall be as follows:

Depth, feet	Manhole Diameter, in
<12	48
≥12	60

- 2. Depth of cover shall be measured from proposed finish surface elevation to the lowest pipe invert.
- F. Steps: Manhole sections shall be cast without steps.

2.02 CAST IRON MANHOLE FRAMES AND COVERS

- A. Location: paved areas
- B. General Requirements:
 - 1. Manhole frames and covers shall be made of ductile iron conforming to ASTM A536, Class 400, or cast iron conforming to ASTM A48, Class 30.
 - 2. Casting shall be smooth, clean, and free from blisters, blowholes, and shrinkage.
 - 3. Frames and covers shall be of the traffic type, designed for H-20 loading.
 - 4. Provide locking bolt-down covers where shown on drawings
 - a. Stainless steel hardware

- b. Non-standard bolt head pattern; provide tool
- C. Fit and Matchmarking: Each manhole cover shall be ground or otherwise finished so that it will fit in its frame without rocking. Frames and covers shall be matchmarked in sets before shipping to the site.
- D. Cover Inscription: Per Standard Drawing
- E. Inspection and Coating: Before leaving the foundry, castings shall be cleaned and subjected to a hammer inspection. Castings shall then be dipped twice in a preparation of asphalt or coal tar and oil applied at a temperature of not less than 290°F, not more than 310°F, and in such a manner as to form a firm and tenacious coating.

2.03 COMPOSITE MANHOLE FRAMES AND COVERS

- A. Location: un-paved areas
- B. Description:
 - 1. Manhole frames and covers with quarter-turn locking mechanism
 - 2. Suitable for one-person operation
 - 3. Max weight of 50 pounds
- C. Performance Criteria:
 - 1. Resistant to corrosion, wear, and UV
 - 2. Load Bearing: H-20 loading
- D. Materials: Fiber reinforced polymer or approved equal

2.04 MANHOLE BASES

- A. Cast in place concrete
 - 1. Class B concrete, Type V cement per Section 03300
 - 2. 3/4-inch-maximum size aggregate
 - 3. Slump of not greater than 2-inches

2.05 EPOXY GROUT

- A. Epoxy grout shall be used in repairing manhole and manhole base surfaces. Epoxy grout shall be made with epoxy and sand. The sand shall be clean, bagged, graded, and kiln dried silica sand. The prepared grout shall wet the contact surface and provide proper adhesion, or a coat of epoxy shall be applied prior to placing the epoxy grout.

2.06 JOINT SEALING COMPOUND

- A. The joint sealing compound shall be a permanently flexible plastic material complying to ASTM C990 and AASHTO M198-751 (Type B).

PART 3 EXECUTION

3.01 WORK WITHIN EXISTING MANHOLES

- A. Any proposed work inside an existing manhole that is part of a sewerage system in service, shall not be undertaken until all the tests and safety provisions of Article 4, Section 1532 "Confined Spaces" State of California Construction Safety Orders have been made.

3.02 EXCAVATION

- A. Excavation for the precast concrete manhole shall be in accordance with Section 02223.

3.03 MANHOLE BASE

- A. General: Manhole bases shall be poured in place against undisturbed soil with concrete. The manhole base shall be poured as one monolithic pour. Limitations for site-mixed and ready-mixed concrete set forth in Section 03300 shall be observed. A 12-inch thick base of 3/4-inch crushed rock shall be placed prior to the placement of concrete for all installations.
- B. Manhole Stub Placement: The manhole stubs and sewer main shall be set before the concrete is placed and shall be rechecked for alignment and grade before the concrete has set. The various sized inlets and outlets to the manhole shall be located as indicated on the plans and as detailed in the detail drawings.
- C. Matching Pipe Crown Elevations: Invert elevations of connecting sewers may vary depending upon sizes. The crown elevation of all pipes shall be the same as the crown elevation of the largest pipe, unless otherwise indicated on the plans.
- D. Channel Configuration: The invert of the manhole base shall be formed so as to provide smooth channels conforming in size and shape to the lower portions of the inlet and outlet pipes. The channel shall vary uniformly in size and shape from inlet to outlet, and a shelf shall be constructed higher than the pipe as indicated on the drawings. The manhole base shall extend 12-inches below the bottom of the lowest pipe.
- E. Transitions: All transitions shall be smooth and of the proper radius to give an uninterrupted transition of flow.
- F. Finishing: The concrete base shall be shaped with a wood float and shall receive a hard steel trowel finish before the concrete sets.
- G. Placement of Additional Mortar: In the event additional mortar is required after initial set has taken place, the surface to receive the mortar shall be primed, and the mortar mixed with a concrete adhesive in the amounts and proportions recommended by the manufacturer and as directed by the District in order to secure as chip-proof a result as possible.
- H. Curing Time Before Further Construction: Unless accepted otherwise by the District in advance, the bases shall set a minimum of 24 hours before the manhole construction is continued.

3.04 INSTALLING MANHOLES

- A. Joints: Precast concrete manhole units shall be set in a bed of grout to make a watertight joint at least 1/2 inch thick with the concrete base or with the preceding unit. Manhole sections shall be set plumb. Inside joints shall be pointed and the excess grout removed. Preformed, cold-applied, ready-to-use, plastic joint sealing compound may be substituted for grout between units and must be used when groundwater is encountered.

- B. Finish Elevation of Manhole Covers: Precast sections shall be assembled so that the cover conforms to the elevation determined by the manhole location as follows, but limited to a maximum of 18-inches from the top of the manhole cone to the top of the ring and cover, unless otherwise instructed by the District.
 - 1. In Paved Area: Top of cover shall be flush with the paving surface.
 - 2. In Shoulder Areas: Top of cover shall be flush with existing surface where it is in traveled way or shoulder and 0.1 foot above existing surface where outside limits of traveled way but not in the existing roadside ditch.
 - 3. In Roadside Ditch or Unpaved Open Areas: Top of cover shall be a minimum of 6-inches above the ground surface and surrounded with a concrete collar. In special instances, as designated by the District or as shown on the plans, the top of the cover shall be flush with the surrounding ground surface and within a square concrete pad 2 feet larger than the manhole frame. Guard posts or paddle boards may be required adjacent to manholes in open areas.
 - 4. Manhole Frame and Cover: The manhole frame shall be bolted to grade ring and secured with grout and cement mortar fillet. After the frames are securely set, the frames and the covers shall be cleaned and scraped free of foreign materials, and shall be ground or otherwise finished as needed so the cover fits in its frame without rocking.
 - 5. Watertightness: It is the intent of these specifications that manholes and appurtenances be watertight and free from infiltration. All manholes are to be banded both inside and outside with cement-mortar grout. Where called for in the plans or supplemental specifications, manholes that are to be given a protective lining or coating shall be free of any seeping or surface moisture.
 - 6. Stubs: Sewer pipe shall be furnished and installed in manholes at the locations shown and in conformance with the detail drawings and plans. All stubs shall be plugged with stoppers as shown on the plans for various sizes of pipe.
 - 7. Sealing Before Completion: In order to prevent accidental use of the new sewer before completion and acceptance, the inlet to existing tie-in manholes shall be sealed with a mechanical plug. Installation of these plugs shall be accepted by the District. Plugs shall be removed at the time of final inspection or as directed by the District.
 - 8. Bulkheads: Brick and mortar bulkheads shall be installed at the downstream end of all unused stub channels over 5 feet long to prevent the creation of a septic condition resulting from ponding of sewage and debris in the unused channels, and until such time as the manhole stub is connected and normal sewage flow can occur. A plug shall be required for all downstream stubs.
 - 9. New Mainline Connections to Existing Manholes: New mainline connections to existing manholes wherein stubs have not been provided shall be made by core drilling through the base, as directed by the District.

10. Backfill: Backfill in accordance with Section 02200.
11. Concrete Collar: Class B concrete collar shall be cast around manhole frames that are flush with the surface. The collar shall be placed after final grading or paving together with final cleanup.
12. Pavement Replacement: Replacement of bituminous or concrete pavement shall be in accordance with the requirements of the governmental agency having jurisdiction.

3.05 TESTING

- A. The adequacy of manholes and appurtenances as to watertightness shall be determined by the District and shall be tested in accordance with Section 15043.

3.06 MANHOLE AND MANHOLE BASE REPAIRS

- A. Manhole sections and bases that exhibit defects in the concrete surface may be rejected. Defective concrete surfaces of manhole sections and bases not rejected shall be repaired by chipping away unsound or imperfect concrete. Edges shall be left sharp and square with the surface. Loose material and dust remaining after chipping shall be removed by means of an air jet. Epoxy grout shall be applied to the surface to be repaired in accordance with the manufacturer's instructions. The grout shall wet the contact surface and provide proper adhesion, or a coat of epoxy shall be applied prior to placing the epoxy grout.

END OF SECTION

SECTION 03462

PRECAST CONCRETE VAULTS

PART 1 GENERAL

1.01 SECTION INCLUDES

- A. Precast concrete vaults
 - 1. Precast concrete meter boxes for meters 2-inch and smaller shall be purchased from the District and installed by the Contractor unless noted otherwise.
 - 2. The Contractor shall furnish and install precast concrete vaults for meter installations 3-inch and larger and other applications.

1.02 RELATED REQUIREMENTS

- A. Section 02200, Earthwork

1.03 REFERENCED STANDARDS

- A. ASTM C31: Standard Practice for Making and Curing Concrete Test Specimens in the Field
- B. ASTM C39: Standard Test Method for Compressive Strength of Cylindrical Concrete Specimens
- C. ASTM C138: Standard Test Method for Density (Unit Weight), Yield, and Air Content (Gravimetric) of Concrete
- D. ASTM C143: Standard Test Method for Slump of Hydraulic-Cement Concrete
- E. ASTM C150: Standard Specification for Portland Cement
- F. ASTM C173: Standard Test Method for Air Content of Freshly Mixed Concrete by the Volumetric Method
- G. ASTM C192: Standard Practice for Making and Curing Concrete Test Specimens in the Laboratory
- H. ASTM C231: Standard Test Method for Air Content of Freshly Mixed Concrete by the Pressure Method
- I. ASTM C857: Standard Practice for Minimum Structural Design Loading for Underground Precast Concrete Utility Structures
- J. ASTM C858: Standard Specification for Underground Precast Concrete Utility Structures
- K. ASTM C891: Standard Practice for Installation of Underground Precast Concrete Utility Structures

- L. ASTM C900: Standard Test Method for Pullout Strength of Hardened Concrete
- M. ASTM C990: Standard Specification for Joints for Concrete Pipe, Manholes, and Precast Box Sections Using Preformed Flexible Joint Sealants
- N. AASHTO M-198: Standard Specification for Joints for Concrete Pipe, Manholes, and Precast Box Sections Using Preformed Flexible Joint Sealants
- O. Federal Specification SS-A-701

1.04 SUBMITTALS

- A. Design calculations and detailed drawings of component sections signed by a registered California Professional Engineer. Show dimensions and materials of construction by ASTM reference and grade.
- B. Shop drawings of grating, grating frame embeds, covers, and all appurtenances
- C. Shop drawings indicating the installation procedures and dimensions and the location of all joints or welded strips
- D. Results of testing required per paragraph of this specification entitled "Quality Assurance"
- E. Qualifications of engineer designing the precast concrete structure
- F. Recommendations for inlet and outlet seals and watertight caulking

1.05 QUALITY ASSURANCE

- A. Precast concrete producer shall demonstrate adherence to the standards set forth in the National Precast Concrete Association Quality Control Manual.
- B. The precast concrete producer shall have been in the business of producing precast concrete products similar to those specified, for a minimum of 5 years. The precast concrete producer shall maintain a permanent quality control department or retain an independent testing agency on a continuing basis. The agency shall issue a report, certified by a licensed engineer, detailing the ability of the precast concrete producer to produce quality products consistent with industry standards.
- C. The precast concrete producer shall show that the following tests are performed in accordance with the ASTM standards indicated. Tests shall be performed for each 150 cu. yd. of concrete placed, but not less frequently than once per week.
 - 1. Slump: C143
 - 2. Compressive Strength: C31, C192, C39
 - 3. Air Content (when air-entrained concrete is being used): C231 or C173
 - 4. Unit Weight: C138
- D. The District may place an inspector in the plant when the products covered by this specification are being manufactured.

PART 2 PRODUCTS

2.01 PRECAST CONCRETE VAULT

- A. General: Comply with requirements of ASTM C858
- B. Cement: Type II or V per ASTM C150
- C. Design loads: Comply with requirements of ASTM C857 using HS-20 live load.
- D. Sizes shall be as specified on the standard drawings for the various sizes and types of services.

2.02 METER BOX COVERS

- A. All meter box covers shall be touch-read type.
- B. Polymer meter box covers shall be installed only in non-traffic locations.
- C. Steel traffic-rated meter box covers shall be installed in traffic locations.

2.03 VAULT FRAMES AND COVERS

- A. Vault frames and covers shall be fabricated aluminum.
- B. Covers shall be fabricated with supports to resist deflection.
- C. All covers shall be hinged. Covers shall have spring assists.
- D. All covers shall be equipped with a hold-open mechanism.
- E. All covers shall be equipped with a flush locking devices.
- F. All vaults that may be subject to equipment or vehicle loading shall have HS-20 live load rated covers. Vaults in non-traffic areas shall have covers rated for 300 pounds per square foot unless specified otherwise by the District.
- G. Size per drawings.
- H. Build up so that the cover is flush with the surrounding surface unless otherwise specified on the drawings or by the District in the field.

2.04 JOINT SEALING COMPOUND

- A. The joint sealing compound shall be a permanently flexible plastic material complying to ASTM C990 and AASHTO M198-751 (Type B).

2.05 WATERPROOFING

- A. Apply waterproofing formulated to comply with Federal Specification SS-A-701.

PART 3 EXECUTION

3.01 EARTHWORK

- A. Excavation and backfill for precast concrete vaults shall be in accordance with Section 02200 and the requirements herein.
- B. The Contractor shall prepare an excavation large enough to accommodate the structure and permit grouting of openings and backfilling operations.
- C. The bottom of the structure shall be placed on 12 inches of compacted, crushed rock sub-base, graded level and to the proper elevation as shown on the plans.

3.02 INSTALLATION

- A. Install per requirements of ASTM C891.
- B. Openings or "knockouts" in precast concrete vaults shall be located as shown on the drawings and shall be sized sufficiently to permit passage of the largest dimension of pipe and/or coupling flange. Upon completion of installation, all voids or openings in the vault walls around pipes shall be filled with 3,000-psi concrete or mortar, using an approved epoxy for bonding concrete surfaces.
- C. After the structure and all appurtenances are in place and accepted, backfill shall be placed to the original ground line or to the limits designated on the plans.
- D. All joints between precast concrete vault sections shall be made watertight using preformed mastic material. The sealing compound shall be installed according to the manufacturer's recommendations to provide a watertight joint which remains impermeable throughout the design life of the structure. All joints shall be filled with dry-pack non-shrink grout.
- E. Frames and covers shall be built up so that the cover is flush with the surrounding surface unless otherwise specified on the drawings or by the District in the field. The Contractor is responsible for placing the cover at the proper elevation where paving is to be installed and shall make all necessary adjustments so that the cover meets these requirements.
- F. Waterproofing shall be applied to the exterior walls of all buried vaults in accordance with the manufacturer's instructions. Protection shall be placed over the waterproofing to prevent damage.

3.03 METER BOXES

- A. Boxes shall be set true to line and to the grade of the top of the curb, sidewalk, or surrounding graded area.
- B. Meter boxes are not to be set until fine grading for landscape grading has been completed by the Developer.
- C. Retaining walls may be required around meter boxes installed on slopes as determined by the District.

END OF SECTION

SECTION 03463

GREASE INTERCEPTORS

PART 1 GENERAL

1.01 SECTION INCLUDES

- A. Precast concrete grease interceptors

1.02 RELATED REQUIREMENTS

- A. Section 02200, Earthwork
- B. Section 03461, Precast Reinforced Concrete Manholes
- C. Section 03462, Precast Concrete Vaults

1.03 REFERENCED STANDARDS

- A. ASTM C31: Standard Practice for Making and Curing Concrete Test Specimens in the Field
- B. ASTM C39: Standard Test Method for Compressive Strength of Cylindrical Concrete Specimens
- C. ASTM C138: Standard Test Method for Density (Unit Weight), Yield, and Air Content (Gravimetric) of Concrete
- D. ASTM C143: Standard Test Method for Slump of Hydraulic-Cement Concrete
- E. ASTM C150: Standard Specification for Portland Cement
- F. ASTM C173: Standard Test Method for Air Content of Freshly Mixed Concrete by the Volumetric Method
- G. ASTM C192: Standard Practice for Making and Curing Concrete Test Specimens in the Laboratory
- H. ASTM C231: Standard Test Method for Air Content of Freshly Mixed Concrete by the Pressure Method
- I. ASTM C890: Standard Practice for Minimum Structural Design Loading for Monolithic or Sectional Precast Concrete Water and Wastewater Structures
- J. ASTM C1613: Standard Specification for Precast Concrete Grease Interceptors
- K. Uniform Plumbing Code (UPC)

1.04 SUBMITTALS

- A. Design calculations and detailed drawings of component sections signed by a registered California Professional Engineer. Show dimensions and materials of construction by ASTM reference and grade.
- B. Shop drawings of grating, grating frame embeds, covers, and all appurtenances
- C. Shop drawings indicating the installation procedures and dimensions and the location of all joints or welded strips
- D. Results of testing required per paragraph of this specification entitled "Quality Assurance"
- E. Qualifications of engineer designing the precast concrete structure
- F. Recommendations for inlet and outlet seals and watertight caulking

1.05 QUALITY ASSURANCE

- A. Precast concrete producer shall demonstrate adherence to the standards set forth in the National Precast Concrete Association Quality Control Manual.
- B. The precast concrete producer shall have been in the business of producing precast concrete products similar to those specified, for a minimum of 5 years. The precast concrete producer shall maintain a permanent quality control department or retain an independent testing agency on a continuing basis. The agency shall issue a report, certified by a licensed engineer, detailing the ability of the precast concrete producer to produce quality products consistent with industry standards.
- C. The precast concrete producer shall show that the following tests are performed in accordance with the ASTM standards indicated. Tests shall be performed for each 150 cu. yd. of concrete placed, but not less frequently than once per week.
 - 1. Slump: C143
 - 2. Compressive Strength: C31, C192, C39
 - 3. Air Content (when air-entrained concrete is being used): C231 or C173
 - 4. Unit Weight: C138
- D. The District may place an inspector in the plant when the products covered by this specification are being manufactured.

PART 2 PRODUCTS

2.01 GREASE INTERCEPTOR

- A. Comply with ASTM C1613.
- B. Cement: Type II or V per ASTM C 150
- C. Design loads: Comply with requirements of ASTM C890 using HS-20 live load.

- D. The interior of the precast unit shall be sealed with a protective coating.
- E. Each grease interceptor shall be permanently and legibly marked with the Manufacturer's name or trademark, model number and UPC certification mark.

2.02 ACCESSORIES

- A. Provide cast iron frames and covers per requirements of Section 03461.
- B. Provide joint sealing compound at all joints per requirements of Section 03461.

PART 3 EXECUTION

3.01 EARTHWORK

- A. Excavation and backfill for precast concrete vaults shall be in accordance with Section 02200 and the requirements herein.
- B. The Contractor shall prepare an excavation large enough to accommodate the structure and permit grouting of openings and backfilling operations.
- C. The bottom of the structure shall be placed on 12 inches of compacted, crushed rock sub-base, graded level and to the proper elevation as shown on the plans.

3.02 INSTALLATION

- A. Grease interceptors shall be installed per Section 03462.

3.03 FIELD QUALITY CONTROL

- A. Vacuum test installed grease interceptor tanks per ASTM C1613.

END OF SECTION

SECTION 09810

EPOXY COATING FOR SEWER MANHOLE REHABILITATION

PART 1 GENERAL

1.01 SECTION INCLUDES

- A. Rehabilitation of existing sanitary sewer manholes
- B. Monolithic spray applied epoxy coating covering all interior surfaces of existing manholes, including bench and invert
- C. Manhole frame and cover replacement

1.02 RELATED REQUIREMENTS

- A. Section 03461, Precast Reinforced Concrete Manholes

1.03 REFERENCED STANDARDS

- A. ASTM: The published standards of the American Society for Testing and Materials, West Conshohocken, PA.
 - 1. ASTM D4263: Standard Test Method for Indicating Moisture in Concrete by the Plastic Sheet Method
 - 2. ASTM D4414: Standard Practice for Measurement of Wet Film Thickness by Notched Gages
 - 3. ASTM D4541: Standard Test Method for Pull-off Strength of Coatings Using Portable Adhesion Testers.
- B. NACE: The published standards of National Association of Corrosion Engineers (NACE International), Houston, TX.
 - 1. NACE SP 0188: Discontinuity (Holiday) Testing of New Protective Coatings on Conductive Substrates
 - 2. NACE No. 6/SSPC SP-13: Surface Prep of Concrete
- C. SSPC: The published standards of the Society of Protective Coatings, Pittsburgh, PA.
- D. SCAQMD rules and regulations

1.04 SUBMITTALS

- A. The following items shall be submitted in accordance with the General Requirements and Section 01330 (Submittal Procedures):
 - 1. A certification letter from the manufacturer of the manhole rehabilitation system products stating that the products to be used are compatible with each other and appropriate for the intended use.
 - 2. Technical data sheet on each product used, including ASTM test results indicating the product conforms to and is suitable for its intended use per these specifications.
 - 3. Documentation that all materials used comply with SCAQMD rules and regulations.
 - 4. Material Safety Data Sheets (MSDS) for each product used.
 - 5. The manufacturer's published instructions for applying the coating system, including conditions, procedures, and qualities that may adversely affect the coating system.
 - 6. Four (4) project references with contact names and phone numbers that used the submitted coating material for coating sewer manholes. The total number of manholes shall be at least 100. All projects shall be at least three (3) years old with no coating failures.

- B. Applicator Qualifications:
 - 1. Manufacturer certification that Applicator has been trained and approved in the handling, mixing, and application of the products to be used
 - 2. Certification by the protective coating manufacturer that the equipment to be used for applying the products are recommended or have been approved and Applicator personnel have been trained and certified for proper use of the equipment
 - 3. Five (5) recent references for the Applicator of projects of similar size and scope indicating successful application on underground concrete or masonry substrates of the specified 100% solids, high-build solvent-free epoxy coating and repair material
 - 4. Proof of any necessary federal, state, or local permits or licenses necessary for the project

- C. Design details and descriptions for the systems, processes, and equipment to be used in site and surface preparation, application, and testing.

- D. A detailed plan for the removal of loose material from the interior sides of the manholes. The plan shall include the tool and equipment to be used in the removal and cleaning process; the method to be used to prevent the material from entering the sewer; the method for removal and disposal; and the final disposal location.

- E. Project specific submittals and procedures for manhole repair materials, including application, cure time, and surface preparation procedures which permit optimum bond strength with the epoxy coating

- F. Method statements and design procedures when confined space entry, flow diversion, debris removal, or bypass is necessary to perform the specified work.

- G. Or Equal Submittal: To be considered as an equal product, said product must meet or exceed the minimum standards included in this specification and either have successfully passed the Los Angeles County "Evaluation of Protective Coatings for Concrete" corrosion testing program and SSPWC 210.2.3.3 (Greenbook "Pickle Jar" Chemical Resistance test) or have been in use in a Moulton Niguel Water District structure of similar environment for at least five (5) years successfully and without failure in the sole and final opinion of the District.

1.05 QUALITY ASSURANCE

- A. Concrete repair material and protective epoxy coating shall be applied by a Certified Applicator of the protective coating manufacturer.
- B. Applicator shall initiate and enforce quality control procedures consistent with applicable ASTM, NACE, SSPC standards, and the protective coating manufacturer's recommendations.
- C. The Contractor shall provide the District a minimum of three (3) days advance notice of the start of any field surface preparation or coating application work.
- D. A Coating Inspector will be provided by the District (District Coating Inspector). The District Coating Inspector will observe daily operations, procedures, and final product testing to ensure adherence to the specifications by Applicator. All work shall be done in the presence of the District Coating Inspector.
- E. Inspection by the District shall not relieve the Contractor of its responsibility to perform the work in accordance with this Specification.
- F. Applicator shall conform to all local, state, and federal regulations including those set forth by OSHA, RCRA, the EPA, and any other applicable authorities.
- G. All surface preparation, coating application, and repair of defective work, if necessary, shall be performed by a California licensed Contractor that is also a manufacturer approved and certified Applicator for the approved epoxy being applied. All reference and requirements herein to and for Applicator shall also apply to the Contractor.
- H. No products shall be allowed on the construction site, which do not conform to South Coast Air Quality Management District (SCAQMD) rules and regulations. Materials shall be delivered unopened to the jobsite in their original containers bearing the manufacturer's label, completely identifying the contents, date of manufacture, volatile organic compounds (VOCs) as required by the SCAQMD, and listing directions for proper use. Materials exceeding the storage life recommended by the manufacturer shall be removed from the jobsite.

1.06 DELIVERY, STORAGE, AND HANDLING

- A. Materials are to be kept dry, protected from weather, and stored under cover.
- B. Protective coating materials are to be stored between 50 deg F and 90 deg F. Do not store near flame, heat, or strong oxidants.
- C. Protective coating materials are to be handled according to their material safety data sheets.

1.07 WARRANTY

- A. The Contractor and epoxy coating manufacturer, jointly, shall warrant all work against defects in materials and workmanship for a period of not less than five (5) years, unless otherwise noted, from the date of final acceptance of the project.
 - 1. The Contractor shall, within a reasonable time after receipt of written notice thereof, repair defects in materials and workmanship which may develop during the warranty period, and any damage to other work caused by such defects or the repairing of same, at his/her own expense and at no additional cost to the District.
 - 2. A Coating Inspector hired by the District shall conduct the field testing and inspection in this specification for all warranty repairs. The Coating Inspector shall observe and document warranty repairs to ensure adherence to the specifications. All repair work shall be done to the satisfaction of the Coating Inspector.

- B. The Contractor shall accompany the District to inspect the manholes each year for the first five (5) years after project completion.
 - 1. A total of five (5) inspections will be required. The manholes to be inspected shall be chosen by the District, and could include all of them, or the District selection.
 - 2. The District will be responsible for opening the manholes, providing traffic control, and performing the inspection and testing inside the manhole.
 - 3. The inspection will include thorough visual inspection using the latest District inspection form to identify pin holes, infiltration, corrosion, delamination, or other product or installation defects.
 - 4. The District may, at its sole discretion, choose to perform holiday testing and bond strength testing. Any defects found in materials or workmanship as warranted shall be corrected by the Contractor at no additional cost to the District.

PART 2 PRODUCTS

2.01 GENERAL

- A. Infiltration sealant, concrete repair material, and protective epoxy coating shall be compatible for use as a complete manhole rehabilitation system.

- B. Materials and supplies provided shall be the standard products of the manufacturer or products standardly used and certified by the epoxy manufacturer as compatible with the approved epoxy top coat.

2.02 INFILTRATION SEALANT

- A. Small active leaks in the manhole shall be sealed with a material that is compatible with the repair products and suitable for top coating with the epoxy protective coating.

- B. Sealant shall be hydrophobic polyurethane or epoxy injection grout certified to be compatible with the approved epoxy to be installed and shall be submitted for review and approval as part of the epoxy submittal package.

2.03 REPAIR MATERIAL

- A. Repair work includes re-pointing, filling, and repairing non-leaking holes, cracks, and spalls in the manhole walls, bench, slabs, and channel prior to installation of the epoxy coating product(s).
- B. Repair material shall be quick-setting epoxy mastic or cementitious material capable of a two inch vertical hang. The material shall be trowel-on or spray-on, depending on the concrete condition and whether application is on vertical or horizontal surfaces.
- C. All repair materials shall be submitted for review and acceptance and shall be certified by the finish epoxy manufacturer as fully compatible with the finish epoxy.

2.04 PROTECTIVE EPOXY COATING

- A. Protective epoxy coating shall be a 100% solids, solvent-free epoxy coating.
- B. The coating shall have bond strength to concrete equal to or greater than the tensile strength of concrete.
- C. The final cured coating shall be resistant to environments with a pH between 1.0 and 13.0 without degradation.
- D. Total dry film thickness (DFT) = 125 mils

2.05 COATING APPLICATION EQUIPMENT

- A. Protective epoxy coating shall be applied with manufacturer approved heated plural component spray equipment. Spray equipment shall be dedicated for application of the specified protective epoxy coating.
- B. Hard to reach areas, sealant and repair material application, and touch-up may be performed using hand tools.

PART 3 EXECUTION

3.01 GENERAL

- A. Appropriate actions shall be taken to comply with local, state, federal regulatory, and other applicable agencies with regard to environment, health and safety.
- B. Installation of the protective coating shall not commence until the concrete substrate has properly cured and been prepared in accordance with these specifications.
- C. During surface preparation and application of repair and epoxy materials, care must be taken so that no loose material or chemicals enter the sewer. Waste disposal shall be the sole responsibility of the Contractor.

- D. The Contractor shall furnish all tools, equipment, materials, and supplies and shall perform all labor required to complete the protective coating of all specified surfaces. This work shall include all surface preparation, pretreatment, coating application, protection of surfaces not to be coated, cleanup, and appurtenant work, in accordance with the requirements of the Contract Documents.

3.02 MANHOLE FRAME AND COVER REPLACEMENT

- A. Remove and dispose of existing manhole frame and cover prior to application of coating.
- B. Remove existing asphalt or concrete pavement as necessary and entire concrete collar, if existing, for frame and cover removal.
- C. Install new manhole frame and cover per District Standard Drawings and per requirements of Section 03461.
- D. Patch pavement surrounding manhole with temporary bagged cold mix asphalt. The use of bulk cold mix asphalt will not be permitted.

3.03 SURFACE PREPARATION

- A. Applicator shall inspect all surfaces specified to receive a protective coating prior to surface preparation. Applicator shall notify the District of any noticeable disparity in the surfaces which may interfere with the proper preparation or application of the repair mortar and protective coating.
- B. If areas of exposed structural steel are encountered, the Contractor shall contact the District immediately for further inspections and instructions.
- C. Minor infiltration shall be sealed with a material meeting the requirements of this specification. If running and gushing leaks (greater than one gallon per minute) are encountered, the Contractor shall contact the District immediately for further inspections and instructions.
- D. All contaminants including oils, grease, unsound or incompatible existing coatings, waxes, form release, curing compounds, efflorescence, sealers, salts, or other contaminants shall be removed.
- E. All concrete that is not sound or has been damaged by chemical exposure shall be removed up to sound concrete or replaced. Sound concrete is defined as concrete prepared to a level of and in accordance with NACE No. 6/SSPC SP-13 and International Concrete Restoration Institute Concrete Service Preparation Level 4 (ICRI CSP Level 4).
- F. Surface preparation method(s) should be based upon the conditions of the substrate and the requirements of the epoxy protective coating to be applied.

- G. Surfaces to receive protective coating shall be cleaned and abraded to produce a surface with adequate profile and porosity to provide a strong bond between the protective coating and the substrate. Surface preparation method, or combination of methods, that may be used include high pressure water cleaning, high pressure water jetting, abrasive blasting, shot-blasting, grinding, scarifying, acid etching, detergent water cleaning, hot water blasting and others as described in NACE No. 6/SSPC SP-13. Whichever method(s) are used, they shall be performed in a manner that provides a uniform, sound, clean, neutralized surface that is not excessively damaged.
- H. The surface, after preparation, shall be inspected and accepted by the District Coating Inspector. Following acceptance, lining of the manhole must be completed within the following two calendar days. A pH test shall be conducted in the presence of the District Coating Inspector and a pH of 7 or greater shall be required prior to coating.

3.04 APPLICATION OF REPAIR MATERIALS

- A. The Contractor shall repair all uneven surfaces, surfaces with exposed aggregate that protrudes more than ½ inch above the surrounding concrete, or has holes more than ½ inch deep.
- B. Repair materials shall be trowel or spray applied utilizing proper equipment on damaged surfaces.
- C. Repair materials shall be applied to provide a smooth surface with an average profile equivalent to coarse sandpaper to optimally receive the protective coating. No bugholes or honeycomb surfaces should remain after the final trowel procedure of the repair mortar. Use a brush finish after troweling to provide a coarse sandpaper-type finish. Repaired surface shall be ±1/16-inch level with the original surface.
- D. The repair materials shall be cured according to the manufacturer's recommendations.

3.05 APPLICATION OF PROTECTIVE EPOXY COATING

- A. Application procedures shall conform to the recommendations of the protective coating manufacturer, including material handling, mixing, environmental controls during application, safety, and spray equipment.
- B. Applicator shall test prepared surface for moisture prior to application of protective epoxy coating in accordance with ASTM D4263. If required, additional drying of concrete shall be done by removal of the moisture sources and ventilation or dehumidification. The surface moisture level immediately prior to coating shall not exceed the manufacturer's recommended moisture level for application of the protective epoxy coating.
- C. Applicator shall test prepared surfaces for pH and other manufacturer recommended physical properties immediately prior to application of the epoxy coating. These properties shall be as recommended by the manufacturer. The pH shall be 7 or greater.
- D. The spray equipment shall be specifically designed to accurately ratio and apply the specified protective coating materials and shall be regularly maintained and in proper working order.

- E. Airless spray application equipment approved by the coating manufacturer shall be used to apply each coat of the protective coating. Air assisted spray application equipment may be acceptable, especially for thinner coats (<10 mils), only if the air source is filtered to completely remove all oil and water.
- F. If necessary, subsequent top coating or additional coats of the protective coating should occur as soon as the basecoat becomes tack free, ideally within 12 hours but no later than the manufacturer stated and approved recoat window for the specified product. Additional surface preparation procedures will be required if this recoat window is exceeded.
- G. The coating shall be installed on the entire manhole including the shelf and trough of the base to 1-inch above the water level. The coating shall not be applied to the cast iron frame and cover and shall not be applied to the trough below an elevation 1-inch above the water level. All coating termination shall be keyed into a ¼-inch by ¼-inch mechanically scored groove. The coating termination at the manhole trough shall be at the vertical portion of the trough 1-inch above the water level. If the frame and cover is to be replaced, the coating shall include the horizontal surface of the uppermost grade ring.
- H. For manholes that specify shelf coating only, the shelf and trough of the base to 1-inch above the water level shall be coated. The coating shall also be applied 6-inches above the shelf on the vertical wall of the manhole section.

3.06 FIELD TESTING AND INSPECTION

- A. Testing and inspection shall be conducted by the District Coating Inspector. The Contractor shall provide access, confined space support and equipment, and traffic control necessary for all testing and inspection activities to be performed by the District Coating Inspector.
- B. Any portion of the coating that does not satisfactorily pass the inspection and testing requirements shall be repaired or replaced by the Contractor at no additional cost to the District. Further, all District coordination, inspection, testing, and other costs related to failed preparation, application, and testing shall be at the expense of the Contractor.
- C. Testing and inspection to be conducted by the District Coating Inspector will include, but not be limited to, the following:
 - 1. Surface Preparation Inspection: The District Coating Inspector will examine the hydro or abrasive blasting equipment used for surface preparation, and will identify areas of insufficient or inadequate cleaning or surface profile, prior to the application of any repair material or protective coatings. The Contractor shall notify the District and the Coating Inspector of the time and date for inspection and approval two working days prior to completing the surface preparation of each manhole and prior to application of the coating.
 - 2. Ambient Conditions: The District Coating Inspector will monitor the air and surface temperatures, relative humidity, and dew point periodically during coating operations.
 - 3. Moisture Content: The moisture content in the concrete prior to application shall be less than that recommended by the manufacturer. The District Coating Inspector will use a "blotter test", or other test method, to determine the moisture content.

MOULTON NIGUEL WATER DISTRICT

4. **Equipment Inspection:** The District Coating Inspector will check that the plural component spray equipment is clean and properly calibrated prior to protective epoxy coating application.
5. **Compressed Air Cleanliness:** The District Coating Inspector will check that the compressed air supply used for operations such as blast cleaning or substrate blowing is adequately free of moisture and oil contaminants.
6. **Mixing:** The District Coating Inspector will observe the mixing of coatings to assure that all components are added and proportioned correctly. The Inspector will check that materials used are approved and that their pot or shelf lives have not been exceeded.
7. **Thickness Testing:** During coating application, a wet film thickness gage, such as those available through Paul N. Gardner Company, Inc., or approved equal, meeting ASTM D4414 - Standard Practice for Measurement of Wet Film Thickness of Organic Coatings by Notched Gages, will be used to ensure a monolithic coating and uniform thickness during application.
8. **Holiday Testing (Spark Testing):** After the protective coating has set hard to the touch, it will be inspected with high-voltage holiday detection equipment in accordance with NACE Recommended Practice for Discontinuity (Holiday) Testing of Protective Coatings (SP 0188-99). Surfaces shall first be dried; an induced holiday will then be made on to the coated concrete surface and will serve to determine the minimum/maximum voltage to be used to test the coating for holidays at that particular area. The spark tester will be initially set at 100 volts per 1 mil (25 microns) of film thickness applied but will be adjusted as necessary to detect the induced holiday. All detected holidays will be marked by the District Coating Inspector. The Contractor shall repair/touch-up holidays in accordance with the protective coating manufacturer's recommendations.
9. **Bond Strength Testing:** Measurement of bond strength of the protective coating to the substrate will be made by the District Coating Inspector in accordance with ASTM D4541. The number of manholes and locations inside the manholes to be tested shall be determined by the District after application of coating. Each manhole tested shall have one or more 20 mm dollies fixed and pulled in accordance with ASTM D4541, using an Elcometer 106 instrument. The adhesion pulls shall exceed 200 psi or concrete failure with more than 50% of the subsurface adhered to the coating. For each test that fails, two additional tests will be performed in the same manhole at locations chosen by the District Coating Inspector. Further bond tests may be performed by the District Coating Inspector to determine the extent of potentially deficient bonded areas. The Contractor shall repair all bond strength test sites in accordance with the manufacturer's recommendations. If two consecutive dollies in the same manhole fail, the liner shall be removed and replaced at the expense of the Contractor.

The District Coating Inspector shall determine whether or not a sample shall be scored prior to initiating the Bond Strength Test.
10. **Visual Inspection:** A visual inspection will be made by the Inspector and manufacturer's representative using the latest NASSCO standard inspection form (if available) or District inspection form. Any deficiencies in the finished coating will be marked and repaired according to the procedures set forth herein by Applicator.

END OF SECTION

SECTION 09900

PAINTING AND COATING

PART 1 GENERAL

1.01 SECTION INCLUDES

- A. Field painting and coatings for non-buried, exposed surfaces
 - 1. Ferrous metal surfaces
 - 2. Galvanized and non-ferrous metal surfaces, where indicated
 - 3. Aluminum in contact with dissimilar materials
 - 4. Plastic surfaces, where indicated

1.02 RELATED REQUIREMENTS

- 1. Section 15056, Ductile-Iron Pipe and Fittings
- 2. Section 15100, Manual Valves
- 3. Section 15139, Fire Hydrants
- 4. Section 15151, Potable Water, Recycled Water, and Wastewater Facilities Identification

1.03 DEFINITIONS

- A. DFT: Dry Film Thickness, mils
- B. Exterior exposure: Outdoors; with or without overhead cover
- C. Ferrous: Metal material containing or consisting of iron (e.g. ductile iron, cast iron, steel)
- D. Interior exposure: Inside a building, vault, etc.
- E. Mil: Thousandth of an inch
- F. Paint: All coating systems materials, which includes pretreatments, primers, emulsions, epoxies, enamels, varnish, stain, sealers and fillers, and other applied materials whether used as prime, intermediate or finish coats

1.04 REFERENCED STANDARDS

- A. The National Association of Pipe Fabricators (NAPF)
 - 1. NAPF 500: Surface Preparation Standard For Ductile Iron Pipe and Fittings in Exposed Locations Receiving Special External Coatings and/or Special Internal Linings
- B. NSF International
 - 1. NSF 61: Drinking Water Systems Components – Health Effects

- C. SSPC: The Society for Protective Coatings
 - 1. SSPC-SP2: Hand Tool Cleaning
 - 2. SSPC-SP6: Commercial Blast Cleaning
 - 3. SSPC-SP10: Near-White Blast Cleaning
 - 4. SSPC-SP16: Brush-off Blast Cleaning Non-Ferrous Metals

1.05 SUBMITTALS

- A. Product data sheets:
 - 1. Manufacturer's technical information, surface preparation instructions, and application instructions for product
 - 2. Each product shall be listed and cross-referenced to the specific coating system.
 - 3. Color charts and sample for each coating system
 - 4. Safety data sheets for each product
- B. Certifications: Letter from manufacturers verifying that the factory applied prime coats are compatible with specified finish coatings
- C. Contractor safety plan
- D. Manufacturer Experience: Submit reference documentation for submitted coating system. Provide list of utility or industrial installations painted, responsible officials, contact information, and date.
- E. Applicators Qualifications: Submit name and experience record of the painting applicator. Provide list of utility or industrial installations painted, responsible officials, architects, or engineers concerned with the project, contact information, date, and the approximate contract price.

1.06 QUALITY ASSURANCE

- A. Manufacturer Qualifications: Minimum of five similar installations with the submitted coating system, which have been in service for more than five years in the United States of America.
- B. Applicator Qualifications: Minimum of five utilities or industrial installation of a similar size or larger, all in Southern California within the last five years.
- C. Permits: All work shall conform to the specifications and requirements of the city having jurisdiction, and other agencies involved. The Contractor shall keep a copy of all the required permits on the job site and comply with all the terms and conditions of said permits.

1.07 PRODUCT DELIVERY, STORAGE AND HANDLING

- A. Delivery of Materials: All materials shall be delivered to the job site in original, new and unopened packages and containers bearing the manufacturer's name and label, and the following information:
 - 1. Name or title of material, stock number, color, and date of manufacture

2. Contents by volume, for major pigment and vehicle constituents
 3. Thinning instructions where recommended, and Application instructions
- B. Storage of Materials:
1. Conform to manufacturer's written recommendations including, but not limited to, product shelf life and recommended storage temperature.
 2. Materials not in actual use shall be stored in tightly covered containers. Containers used in storage, mixing, and application of paint shall be maintained in a clean condition, free of foreign materials and residue.

1.08 AMBIENT CONDITIONS

- A. Water-base paints shall be applied only when the temperature of surfaces to be painted and the surrounding air temperatures are between 55-degrees F and 90-degrees F unless otherwise permitted by the paint manufacturer's printed instructions.
- B. Other paints shall be applied only when the temperature of the surfaces to be painted and the surrounding air temperatures are between 65-degrees F and 95-degrees F, unless otherwise permitted by the paint manufacturer's printed instructions.
- C. Paint shall not be applied in snow, rain, fog, or mist, when the relative humidity exceeds 85 percent, or to damp or wet surfaces, unless specifically permitted by the manufacturer's printed instructions.
- D. Painting may be continued during inclement weather only if the areas and surfaces to be painted are enclosed and heated within the temperature limits specified by the paint manufacturer during application and drying periods, and there is no danger of condensation on the surfaces being painted.
- E. Adequate illumination and ventilation shall be provided in all areas where painting operations are in progress.

PART 2 PRODUCTS

2.01 PAINT MATERIALS

- A. The best grade of the various types of coating suitable for the intended use as regularly manufactured by acceptable paint material manufacturers shall be provided.
- B. Primers produced by the same manufacturer as the intermediate and finish coats shall be provided. Use only thinners recommended by the paint manufacturer, and use only to recommended limits. The District's acceptance shall be obtained prior to thinning any material.
- C. Provide coating systems that withstand normal washing as required for removing grease, oil, chemicals, etc., without showing discoloration, loss of gloss, staining, or other damage.
- D. Provide coating materials suitable for the intended use and recommended by the manufacturer for the intended service.

- E. Lead content shall not exceed amount permitted by federal, state, and local government laws and regulations.
- F. Coatings specified for application on submerged concrete or metal in contact with potable water shall conform to the requirements of NSF 61.
- G. Coatings shall comply with South Coast Air Quality Management District Requirements.

2.02 EPOXY COATING

- A. Type:
 - 1. Amine-type epoxy coating
 - 2. Self-priming
- B. Finish: Semi-gloss or satin
- C. Percent solids content: 66 to 75-percent

2.03 URETHANE COATING

- A. Type: Aliphatic acrylic polyurethane coating
- B. Finish: Gloss or semi-gloss
- C. Percent solids content: 66 to 70-percent

2.04 HIGH-SOLIDS EPOXY COATING

- A. Type:
 - 1. Amine-type epoxy coating
 - 2. Self-priming
- B. Finish: Gloss or semi-gloss
- C. Percent solids content: 98 to 100-percent

2.05 SULFIDE-RESISTANT EPOXY COATING

- A. Type:
 - 1. Amine-type epoxy coating
 - 2. Self-priming
 - 3. Resistant to 98-percent sulfuric-acid
- B. Percent solids content: 100-percent

2.06 BITUMINOUS MASTIC COATING

- A. Type:
 - 1. Bituminous tar mastic coating
 - 2. Self-priming
- B. Percent solids content: 69-percent (minimum)

PART 3 EXECUTION

3.01 EXAMINATION

- A. The Contractor and his applicator shall examine the areas and conditions under which painting work is to be performed and notify the District in writing of conditions detrimental to the proper and timely completion of the Work. The Contractor shall not proceed with the work until unsatisfactory conditions have been corrected in a manner acceptable to the District.
- B. The Contractor shall not paint over dirt, rust, scale, grease, moisture, scuffed surfaces, or conditions otherwise detrimental to the formation of a durable paint film.

3.02 PROTECTION OF IN-PLACE CONDITIONS

- A. Protect all items not to be painted from cleaning, blasting, and new painting splatters and overspray:
 - 1. Remove, mask, or otherwise protect hardware, grease fittings, lighting fixtures, switchplates, stainless steel, brass, copper, bronze, galvanized, and aluminum surfaces, machined surfaces, couplings, shafts, bearings, nameplates on machinery, and other surfaces not specified elsewhere to be painted.
 - 2. Provide drop cloths to prevent paint materials from falling on or marring adjacent surfaces.
 - 3. Protect working parts of mechanical and electrical equipment from damage during surface preparation and painting process.
 - 4. Mask openings in motors to prevent paint and other materials from entering.
 - 5. Protect surfaces adjacent to or downwind of Work area from overspray.
 - 6. After painting operations begin in a given area, broom cleaning will not be allowed; cleaning shall then be done only with commercial vacuum cleaning equipment.
 - 7. Thoroughly clean all accidental spills, splatters, and overspray. Any damage or stains to finishes, equipment, or concrete shall be restored to original condition to the District's satisfaction.
 - 8. "Wet Paint" signs shall be provided as required to protect newly painted finishes. All temporary protective wrapping provided for protection shall be removed after completion of painting operations.

3.03 SURFACE PREPARATION

- A. Perform surface preparation per the coating system schedule specified herein.

- B. Conform to manufacturer's written requirements for each particular substrate. If proper application of the coating system requires a more stringent surface preparation than is specified herein, comply with manufacturer's requirements at no additional cost to the District.
- C. Surfaces to be painted shall be cleaned before applying paint or surface treatments. Oil and grease shall be removed with clean cloths and cleaning solvents prior to mechanical cleaning. Remove all sharp edges, burrs, and weld spatter.
- D. The cleaning and painting shall be coordinated so that dust and other contaminants from the cleaning process will not fall in wet, newly painted surfaces.
- E. Before painting is started in any area, it shall be broom cleaned and excessive dust shall be removed.
- F. Do not sandblast or prepare more surface area than can be coated in one day or less.

3.04 MATERIALS PREPARATION

- A. Tinting:
 - 1. Undercoats shall be tinted to match the color of the finish coat, but provide sufficient difference in shade of undercoats to distinguish each separate coat.
 - 2. A code number shall be provided to identify material tinted by the manufacturer.
- B. Mixing:
 - 1. Coating materials produced by different manufacturers shall not be mixed, unless otherwise permitted by the manufacturer's instructions.
 - 2. Painting materials shall be mixed and prepared in strict accordance with the manufacturer's written directions.
 - 3. All materials shall be stirred before application to produce a mixture of uniform density and as required during the application of the materials. Any film that may form on the surface shall not be stirred into the material. The film shall be removed and, if necessary, the material shall be strained before using.
 - 4. The Contractor shall mix only in mixing pails placed in a suitably sized non-ferrous or oxide resistant metal pans to protect concrete floor from splashes or spills which could stain exposed concrete or react with subsequent finish floor material. The Contractor shall thoroughly clean all accidental spills and any damage to finish or concrete shall be restored to original condition to the District's satisfaction.
 - 5. Paint shall be mixed and applied only in containers bearing accurate product name of material being mixed or applied.

3.05 APPLICATION

- A. Apply coatings by brush, roller, air spray, or airless spray in accordance with manufacturer's written instructions.
 - 1. If the manufacturer of the coating system requires a more stringent dry film thickness than is specified herein, comply with manufacturer's requirements at no additional cost to the District.

MOULTON NIGUEL WATER DISTRICT

2. The number of coats and paint film thickness required is the same regardless of the application method.
 3. The first-coat of material shall be applied to surfaces that have been cleaned, pretreated or otherwise prepared for painting as soon as practicable after preparation and before subsequent surface deterioration.
 4. Sufficient time between successive coatings shall be allowed to permit proper drying per the manufacturer's written instructions. The Contractor shall not recoat until paint has dried to where it feels firm, does not deform or feel sticky under moderate thumb pressure, and the application of another coat of paint does not cause lifting or loss of adhesion of the undercoat.
 5. Do not double back with spray equipment for the purpose of building up film thickness of 2 coats in one pass.
 6. All brush coats shall be brushed-out and worked onto the surfaces in an even film.
 7. Work shall be free of cloudiness, spotting, holidays, brush marks, sags, ropiness, runs, bridges, shiners, laps, or other imperfections.
- B. Provide complete coverage to dry film mil thickness specified.
1. In situations of discrepancy between manufacturer's square footage coverage rates and mil thickness, mil thickness requirements govern.
 2. When color or undercoats show through, apply additional coats until paint film is of uniform finish and color. The Contractor shall completely cover to provide an opaque, smooth surface of uniform finish, color, appearance, and coverage.
 3. The Contractor shall insure that all surfaces, including edges, corners, crevices, welds, and exposed fasteners receive a film thickness equivalent to that of flat surfaces.
- C. Temporarily remove pipe clamps and hangers prior to painting installed pipe.
- D. Provide all necessary air monitoring, ventilation, confined space training, and personal protection equipment.
- E. Conform to all federal, state, local, and health codes/requirements.

3.06 COATING SYSTEMS SCHEDULE

- A. Provide the following coating systems for all of the following surfaces:
- B. System "1": Ferrous Metals, Interior Exposure, Non-Immersed:
 - 1. Use on the following items or areas:
 - a. Interior exposed ferrous metals including structural steel and miscellaneous metals
 - b. Interior exposed ferrous piping, fittings, valves, appurtenances, and pipe supports
 - 2. Surface Preparation:
 - a. Steel: SSPC-SP 6 Commercial Blast
 - b. Ductile/cast iron: NAPF 500 Solvent Cleaning and Abrasive Blast Cleaning
 - 3. Coating Material and Dry Film Thickness
 - a. Primer: Epoxy; 1 coat, 3.0 to 5.0 dry mils
 - b. Intermediate: Epoxy; 1 coat, 3.0 to 5.0 dry mils
 - c. Finish: Epoxy; 1 coat, 4.0 to 6.0 dry mils
- C. System "2": Ferrous Metals, Exterior Exposure:
 - 1. Use on the following items or areas:
 - a. Exterior exposed ferrous metals including structural steel and miscellaneous metals
 - b. Exterior exposed ferrous piping, fittings, valves, appurtenances, and pipe supports
 - 2. Surface Preparation:
 - a. Steel: SSPC-SP 6 Commercial Blast
 - b. Ductile/cast iron: NAPF 500 Solvent Cleaning and Power Tool Cleaning
 - 3. Coating Material and Dry Film Thickness
 - a. Primer: Epoxy; 1 coat, 3.0 to 5.0 dry mils
 - b. Intermediate: Epoxy; 1 coat, 4.0 to 6.0 dry mils
 - c. Finish: Urethane; 1 coat, 3.0 to 5.0 dry mils
- D. System "3": Ferrous Metals, Immersed (potable or recycled water):
 - 1. Use on the following items or areas:
 - a. Immersed ferrous metals including structural steel and miscellaneous metals
 - b. Immersed ferrous piping, fittings, valves, appurtenances, and pipe supports
 - 2. Surface Preparation:
 - a. Steel: SSPC-SP 10 Near-White Blast Cleaning
 - b. Ductile/cast iron: NAPF 500 Solvent Cleaning and Abrasive Blast Cleaning

3. Coating Material and Dry Film Thickness
 - a. Option 1: Complete System: High-solids epoxy; 1 coat, 16.0 to 30.0 dry mils
 - b. Option 2: Complete System: Epoxy; 3 coats, 5.0 to 6.0 dry mils (each)

- E. System "4": Ferrous Metals, Immersed (sewer):
 1. Use on the following items or areas:
 - a. Immersed ferrous metals including structural steel and miscellaneous metals
 - b. Immersed ferrous piping, fittings, valves, appurtenances, and pipe supports
 2. Surface Preparation:
 - a. Steel: SSPC-SP 10 Near-White Blast Cleaning
 - b. Ductile/cast iron: NAPF 500 Solvent Cleaning and Abrasive Blast Cleaning
 3. Coating Material and Dry Film Thickness
 - a. Complete System: Sulfide-resistant epoxy; 1 coat, 30.0 to 40.0 dry mils

- F. System "5": Galvanized Metal and Non-Ferrous Metal, Exterior Exposure:
 1. Use on the following items or areas:
 - a. Galvanized metal surfaces where indicated
 2. Surface Preparation: SSPC-SP 16: Brush-Off Blast Cleaning for Non-Ferrous Metals
 3. Coating and Dry Film Thickness
 - a. Primer: Epoxy; 1 coat, 3.0 to 5.0 dry mils
 - b. Finish: Urethane; 1 coat, 3.0 to 5.0 dry mils

- G. System "6": All Aluminum in Contact with Dissimilar Materials:
 1. Use on the following items or areas:
 - a. Aluminum in contact with steel, stainless steel, or other metals
 - b. Aluminum in contact with concrete
 2. Surface Preparation: SSPC-SP 16: Brush-Off Blast Cleaning for Non-Ferrous Metals
 3. Coating Material and Dry Film Thickness
 - a. Option 1: Complete system: Epoxy; 2 coats, 5.0 to 6.0 dry mils (each)
 - b. Option 2: Complete system: Bituminous mastic; 1 coat, 10.0 to 20.0 dry mils

- H. System "7": Plastics, Exterior Exposure:
 1. Use on the following items or areas:
 - a. Exterior exposed plastic enclosures where indicated
 2. Surface Preparation
 - a. Hand sand plastic surfaces to be coated with medium grit sandpaper to provide tooth for coating system

3. Coating Material and Dry Film Thickness
 - a. Primer: Epoxy; 1 coat, 3.0 to 5.0 dry mils
 - b. Finish: Urethane; 1 coat, 3.0 to 5.0 dry mils

3.07 COLOR SCHEDULE

A. Coat items per the following color schedule:

Service	Item	Color Name	Color Code
Potable Water	Piping and equipment	Moulton Blue	Tnemec B0821
	Public fire hydrants and bollards	Safety Yellow	Tnemec 02SF
	Private fire system	Safety Red	Tnemec 06SF
	Steel reservoir exterior	Desert Sand	Tnemec 04BR
Recycled Water	Piping and equipment	Moulton Magenta	Tnemec R0581
Wastewater	Lift station piping and equipment	Moulton Tan	Tnemec S0356
		Moulton Brown	Tnemec D2161

B. The color trade name is provided as a standard color only and does not indicate preference for a particular manufacturer. Match color based on physical paint sample.

3.08 FIELD QUALITY CONTROL

- A. Maintain an accurate written record of the coatings used each day.
 1. A copy of this record shall be furnished to the District at the close of each working day. This record shall list:
 - a. Coating manufacturer's product number
 - b. Amount of each coating in gallons used in the day and amount of excess mixed paint left over at the end of each day
 - c. Component ratio of mixed paints and any approved thinning procedures
- B. Notify the District prior to initial coat and after completion of each successive coat of paint to schedule inspection and checking of film thickness.
- C. Dry-Film Thickness Testing
 1. Measure thickness of each coat with a magnetic type dry-film thickness gage to verify compliance with specifications.
 2. Provide dry-film thickness gage as manufactured by Mikrotest, Elcometer, or equal.
 3. Do not measure within eight hours after application of the coating.

D. Holiday Testing:

1. Test the finish coat (except galvanizing) for holidays and discontinuities with an electrical holiday detector, low-voltage, wet-sponge type.
2. Measuring equipment shall be provided by the Contractor. Provide detector as manufactured by Tinker and Razor, or equal.

E. Non-Conforming Work:

1. If the item has an improper finish color or insufficient film thickness as determined by the District, the surface shall be cleaned and topcoated with the specified paint material to obtain the specified color, coverage, and DFT.
2. Visible areas of chipped, peeled, or abraded paint shall then be primed and finish coated in accordance with these specifications.

3.09 CLEANING

- A. During the progress of the Work, all discarded paint materials, rubbish, cans and rags shall be removed from the site at the end of each work day.
- B. Upon completion of painting work, all paint-spattered surfaces shall be cleaned. Spattered paint shall be removed by proper methods of washing and scraping, using care not to scratch or otherwise damage finished surfaces.
- C. At the completion of work of other trades, all damaged or defaced painted surfaces shall be touched-up and restored, as determined by the District.

END OF SECTION

SECTION 13110

DISSIMILAR METAL CONNECTIONS

PART 1 GENERAL

1.01 SECTION INCLUDES

- A. Insulating flange kits
- B. Dielectric unions
- C. Insulating bushings
- D. Casing seals and spacers
- E. Wax tape wrap system

1.02 REFERENCED STANDARDS

- A. American Water Works Association (AWWA)
 - 1. AWWA C210: Liquid-Epoxy Coating Systems for the Interior and Exterior of Steel Water Pipelines
 - 2. AWWA C213: Standard for Fusion-Bonded Epoxy Coating for the Interior and Exterior of Steel Water Pipelines
 - 3. AWWA C217: Wax Coating Systems for Underground Piping Systems
- B. NACE International
 - 1. NACE RP0286: Electrical Isolation of Cathodically Protected Pipelines
- C. NSF International
 - 1. NSF 61: Drinking Water Systems Components – Health Effects

1.03 SUBMITTALS

- A. Manufacturer's catalog cutsheets
- B. Test Results: The following test results shall be submitted to the District:
 - 1. Insulator test results for casing and insulating flange kits

PART 2 PRODUCTS

2.01 FLANGE INSULATION KITS

- A. Insulating flange kits shall contain full face gaskets, full length sleeves and double washers (steel and phenolic) on each end. Flange insulation kits shall consist of:
 - 1. Insulating Gaskets: Gaskets for flanges 16-inches or greater shall be Type E fullfaced Phenolic with Rectangular Nitrile or Viton O-Ring Seal. For flanges less than 16-inches, gaskets shall be Type E fullfaced neoprene faced phenolic.
 - 2. Insulating Stud Sleeves for Bolts: Insulating sleeves shall be 1/32 inch thick, G10 laminated glass tube. For installation on threaded studs use full length sleeves. For installation on threaded bolts, i.e., at butterfly valve flange bonnets and bases, the sleeves shall be half-length.
 - 3. Insulating Washers for Bolts: Insulating washers shall be 1/8-inch G10 laminated glass.
 - 4. Steel Washers Over Insulating Washer: 1/8-inch thick cadmium plated steel to be placed between the nut and the insulating washer.

2.02 DIELECTRIC UNIONS

- A. Union nut, two tailpieces, and a gasket that separates the tailpieces to prevent an electric current from occurring
- B. Threaded or soldered connections
- C. Forged construction, Class 3000 Service

2.03 INSULATING BUSHINGS

- A. Design:
 - 1. Isolate dissimilar metals
 - 2. Designed for heavy hex wrenching
- B. Material: Nylon

2.04 CASINGS

- A. Casing seals:
 - 1. Designed to prevent moisture intrusion into the casing annular space shall be either a rubber link or pull-on sleeve type.
 - a. Rubber link casing seals are made of molded, solid, synthetic rubber and are connected together by corrosion resistant bolts and nuts. After the links are placed in the casing opening, the bolts are turned to create an airtight and watertight seal.
 - b. Sleeve casing seals are made of 1/8-inch thick, synthetic rubber. The sleeve is fastened to the exterior of the casing and carrier pipe using stainless steel strapping.

- B. Casing Spacers: Casing insulators used to prevent contact between the casing and carrier pipe shall be comprised of a fusion coated, 8-inch wide steel band with 2-inch wide glass reinforced plastic runners.

2.05 WAX TAPE COATING SYSTEM

- A. General: Conform to requirements of AWWA C217.
- B. Primer: Blend of petrolatum or petroleum wax that may contain suitable inhibitor. Primer shall be supplied by tape manufacturer and shall protect metal surfaces and promote adhesion.
- C. Wax Tape: Wrap primed surfaces with a synthetic fabric tape saturated with a blend of petrolatum, plasticizers, and corrosion inhibitors that is easily formable over irregular surfaces. A compatible petrolatum filler should be used to smooth over irregular surfaces.
- D. Outer Covering: The primed and wax tape wrapped flange shall be wrapped with a plastic tape covering consisting of three (3) layers of 1.5 mil, polyvinylidene chloride or PVC, high cling membranes wound together as a single sheet.

PART 3 EXECUTION

3.01 FLANGE INSULATION KITS

- A. Insulating kits shall be installed to isolate any flanged dissimilar metal pipes.
- B. Moisture, soil, or other foreign matter must be carefully prevented from contacting any portion of the mating surfaces prior to installing insulator gasket. If moisture, soil or other foreign matter contacts any portion of these surfaces, the entire joint shall be disassembled, cleaned with a suitable solvent and dried prior to reassembly. Care shall be taken to prevent any excessive bending or flexing of the gasket.
- C. Alignment pins shall be used to properly align the flange and gasket.
- D. The manufacturer's recommended bolt-tightening sequence shall be followed. Bolt insulating sleeves shall be centered within the insulation washers so that the insulating sleeve is not compressed and damaged.
- E. Neither aluminum, graphite, nor any other electronically conductive pigment shall be used in paints or coatings on the flanges, bolts, or washers of any insulating device.

3.02 DIELECTRIC UNIONS

- A. Install dielectric unions on all threaded or soldered dissimilar metal pipes.
- B. Moisture, soil, or other foreign matter must be carefully prevented from contacting any portion of the mating surfaces prior to installing insulator gasket. If moisture, soil or other foreign matter contacts any portion of these surfaces, the entire joint shall be disassembled, cleaned with a suitable solvent and dried prior to reassembly.

3.03 CASINGS

- A. The casing end seal shall be installed wherever a metallic pipeline passes through a steel casing in order to restrict water intrusion into the casing annular space. The casing seal shall be installed according to the manufacturer's recommendations.
- B. The encased sections of metallic piping shall be electrically isolated from the casing. Use casing insulators to prevent metallic contact and ensure a minimum amount of standoff between casing and carrier pipe. Distance between spacers shall be small enough to prevent excessive sagging of the line.

3.04 COATINGS FOR CONCRETE-ENCASED METALLIC PIPE

- A. Provide dielectric coating on all metallic pipes, wall sleeves, and conduits encased in cast-in-place concrete structures to prevent pipe contact with the concrete and/or reinforcing steel.
- B. Dielectric coating shall be epoxy material conforming to NSF 61 and AWWA C210 or AWWA C213.

3.05 WAX TAPE WRAP

- A. Install wax tape coating system on all buried insulating flange kits and all joints, valves, and coupling with joint bonding per the requirements of AWWA C217. Where discrepancies exist between current AWWA C217 and this specification, the more stringent requirements shall govern.
- B. Install wax tape tight and without air pockets. Apply three neat and tight outer layers over the flange, valve, or coupling. Individually wrap each bolt or tie-rod.
- C. The edges of flanges 18-inches in diameter and larger shall be wrapped with an additional layer of 10-mil pipe tape (two layers, 50-percent overlap) to protect wax tape during backfilling process.

3.06 FIELD QUALITY CONTROL

- A. Notification for Testing: The Contractor shall notify the District at least five days in advance of testing.
- B. Insulating Flange Kits: Retain certified NACE Cathodic Protection Tester to test and confirm isolation.
 - 1. Method:
 - a. Buried insulators must be tested and accepted by the District's Corrosion Engineer prior to application of wax tape and backfilling.
 - b. The assembled flange shall be tested with a Gas Electronics Model 601 Insulator Checker or equivalent instrument that is specifically designed for the testing of insulating flanges.
 - c. The testing shall be done in accordance with NACE RP0286-97.

MOULTON NIGUEL WATER DISTRICT

- d. If a short is indicated, each bolt shall be tested to verify the integrity of each insulating sleeve before the flange is disassembled. The Contractor shall find any and all shorts or shorted bolts.
 - 2. Acceptance: The installation of the insulating flange kit shall be considered complete when the testing instrument indicates that no shorts or partial shorts are present. Any deflection of the meter, no matter how small, indicates a short. All disassembly and re-assembly necessary for acceptance shall be done at no additional cost to the District.
- C. Casing Isolation: Retain certified NACE Cathodic Protection Tester to test all casings to verify that they are metallicity isolated from the pipe.
- 1. Method:
 - a. The casing shall be considered fully isolated if the difference between the structure-to-soil potential of the casing and the pipe is more than 30 millivolts.
 - b. If this potential difference is less than 30 millivolts the casing and the pipe may still be adequately isolated. In this case the Corrosion Engineer shall submit a test approach and test data to verify isolation.
 - 2. Acceptance: A potential difference of 30 millivolts or greater or the District's acceptance of the Corrosion Engineer's test report.

END OF SECTION

SECTION 13121

CORROSION PROTECTION

PART 1 GENERAL

1.01 SECTION INCLUDES

- A. Zinc Anodes
- B. Wire and Cable
- C. Alumino-Thermic Weld Primer and Caps

1.02 RELATED REQUIREMENTS

- A. Section 02223, Trenching, Backfilling, and Compacting
- B. Section 09900, Painting and Coating
- C. Section 13110, Dissimilar Metal Connections

1.03 REFERENCED STANDARDS

- A. ASTM International (ASTM)
 - 1. ASTM B3: Standard Specification for Soft or Annealed Copper Wire
 - 2. ASTM B8: Standard Specification for Concentric-Lay-Stranded Copper Conductors, Hard, Medium-Hard, or Soft
 - 3. ASTM B418: Standard Specification for Cast and Wrought Galvanic Zinc Anodes
 - 4. ASTM D1248: Standard Specification for Polyethylene Plastics Extrusion Materials for Wire and Cable
 - 5. ASTM D2220: Standard Specification for Poly (Vinyl Chloride) Insulation for Wire and Cable, 75°C Operation
- B. Underwriters Laboratory
 - 1. UL 83: Thermoplastic Insulated Wires and Cables

1.04 SUBMITTALS

- A. Manufacturer's catalog cutsheets
- B. As-built Drawings: The Contractor shall maintain as-built drawings showing the exact locations of all corrosion monitoring test stations, insulators, and wire trenching runs. Location changes from the design drawings shall be legibly indicated in red on a blue line copy of the design drawings. These drawings shall be submitted to the District before the work is considered complete.

- C. Test Results: The following test results shall be submitted to the District:
 - 1. Continuity test report
 - 2. Insulator test results
 - 3. Anode and pipe lead wire integrity tests results

PART 2 PRODUCTS

2.01 ZINC ANODES FOR NEW SERVICES AND AIR-VACS

- A. Zinc Anode: Anode shall conform to ASTM B 418, Type II and shall be a prepackaged zinc alloy ingot having a chemical composition not exceeding the following limits:
 - 1. Aluminum: 0.005-percent Max.
 - 2. Cadmium: 0.003-percent Max.
 - 3. Iron: 0.0014-percent Max.
 - 4. Zinc: Remainder
- B. Ingot Weight: 12 pounds
- C. Anode Backfill: Each zinc anode shall be prepackaged in a permeable cloth bag with a backfill of the following composition or installed bare and backfilled with material having the following composition:
 - 1. Gypsum: 75-percent
 - 2. Powdered Bentonite: 20-percent
 - 3. Anhydrous Sodium Sulfate: 5-percent
- D. Backfill grains: Capable of 100-percent passing through a 100 mesh screen. The backfill shall be firmly packed around the anode by mechanical vibration to density which will maintain the zinc ingot in the center of the cloth bag and surrounded by at least 1-inch of backfill.
- E. Steel Core: Anode shall be cast full length with an electrogalvanized 1/4-inch diameter steel core which shall be exposed at one end for connection of the anode lead wire.
- F. Anode Lead Wire: Wire shall be attached to the steel core with silver solder by the manufacturer. The connection shall be encapsulated in a heat-shrinkable sleeve. Anode lead wire shall be of sufficient length to extend from the anode to the designated termination point without a splice. Wires with cut or damaged insulation will not be accepted and replacement of the entire lead will be required at the Contractor's expense.

2.02 WIRE AND CABLE

- A. Material: Copper conforming to ASTM Standards B3 or B8
- B. Insulation: All DC wires shall be stranded copper with high molecular weight polyethylene (HMWPE) or thermal plastic (THWN) insulation suitable for direct burial in corrosive soil and water, conforming to UL 83 and ASTM Standards B3 or B8.

1. HMWPE insulation and shall conform to the requirements of ASTM D1248 Type 1, Class C.
2. THWN insulation shall conform to the requirements of ASTM D2220.

2.03 ALUMINO-THERMIC PRIMER AND CAPS

- A. Weld Cap Primer: Weld cap primer shall be an elastomer-resin based corrosion resistant primer for underground services.
- B. Weld Caps: Alumino-thermic welds shall be sealed with a pre-fabricated plastic cap filled with bituminous mastic compound on a base of elastomeric tape or a polymer-coated synthetic fabric with a synthetic adhesive
- C. Sizing: Weld charge size, alloy, and mold size shall be as specified by the manufacturer of the weld kit for use on steel or ductile iron pipe.

PART 3 EXECUTION

3.01 ZINC ANODES

- A. General: Where called for on the drawings, prepackaged zinc anodes shall be installed in excavated, drilled, or punched holes a minimum of 8-inches in diameter. Anodes shall be installed below the level of the service or air/vac line, with a minimum separation of 2 feet between the copper water tubing and the zinc anode maintained at all times. Anodes shall not be lowered, transported, handled, or lifted by the lead wire.
- B. Location: Anode shall be installed approximately midway between pipeline and meter box.
- C. Backfilling: After the prepackaged anode is placed in the hole, approximately 5 gallons of water shall be poured into the hole so that the anode is completely covered with water. Allow water to soak for 30 minutes. Stone-free native soil shall then be used to backfill the anode hole. Imported sand shall not be used for backfilling. The anode hole shall be backfilled in stages and carefully compacted to ensure that no voids exist around the bag and that the bag and anode wire are not damaged. After backfill is level with the top of the anode, another 5 gallons of water shall be poured into the hole to completely saturate the soil backfill. More water shall be added if it is suspected that the backfill is not completely saturated. Care shall be taken to avoid damage to the anode and anode lead wires.
- D. Anode Lead Wire: The anode lead wire shall extend from the anode along the copper pipe to the water service or air/vac meter box. The anode lead wire shall be attached to the copper water service or air/vac riser inside the meter box using a bronze mechanical grounding clamp.

3.02 BOND WIRE

- A. Wire Quantity and Arrangement:
 1. Two or three bond wires shall be installed on ductile iron and steel pipe across each buried, unwelded pipe joint or mechanical joint including valves, couplings, special fittings, and flanges except insulating flange.

2. Bond wires shall not be attached to valve bodies, but instead to the flange of the valve.
3. Bond wires shall have minimal slack wire at each weld but otherwise be as short as possible.

B. Connection to Pipe:

1. Preparation of Wire: Use a cutter to prevent deforming wire ends. Remove only enough insulation from the wire to allow the weld connection to be made. Do not use a hacksaw for cutting.
2. Preparation of Metal:
 - a. Remove all coating, dirt, grime and grease from the metal pipe at weld location by wire brushing and/or use of suitable safe solvents. Clean the pipe to a bright, shiny surface free of all serious pits and flaws by use of mechanical grinder or a file.
 - b. The area of the pipe where the attachment is to be made must be absolutely dry. Failure to provide a dry surface for welding will result in a poor quality weld and could result in serious injury to the workman.
3. Alumino-Thermic Weld Wire to Pipe:
 - a. The attachment of copper wire shall be made using an alumino-thermic weld.
 - b. The wire is to be held at a 30-degree to 45-degree angle to the surface when welding.
 - c. Manufacturer's recommended cartridge size and type shall be used.
 - d. Only one wire shall be connected with each weld.
4. Coating of All Completed Welds:
 - a. Thoroughly clean by wire brushing the area to be coated.
 - b. The area must be completely dry.
 - c. Overcoat the weld cap with a bituminous mastic coating per Section 09900 in accordance with the manufacturer's recommendations.
 - d. Completely coat the weld, all bare pipe surfaces around the weld and any exposed copper wire.
 - 1) For non-mortar coated pipe, extend coating 3 inches beyond weld cap.
 - 2) For mortar coated pipe, apply coating up to but not over mortar.
 - a) Allow sufficient time to dry prior to repair of the mortar coating on steel pipe.
 - b) The mortar coating shall be repaired after the bituminous weld coating has dried, using fast setting, non-shrinkable mortar to restore the original outside diameter of the pipe at each weld location.

3.03 FIELD QUALITY CONTROL

- A. Notification for Testing: The Contractor shall notify the District at least five days in advance of testing.
- B. Bond Wire Welds: Inspect all wire insulation for damage and test all bond wire welds.
 1. Test Method:

MOULTON NIGUEL WATER DISTRICT

- a. All wire insulation shall be visually inspected. As soon as the weld has cooled, all completed wire connection welds shall be tested, in the presence of the District, for strength by striking the weld with a sharp blow with a 2-pound hammer while pulling firmly on the wire.
 - b. Welds failing this test shall be re-welded and re-tested.
- C. Pipeline Continuity Through Bonded Or Mechanical Joints: Retain certified NACE Cathodic Protection Tester to test all sections that contain bonded joints, valves, and couplings.
- 1. Method:
 - a. Continuity is verified when the measured linear resistance of section of pipe being tested is approximately equal its theoretical value.
 - b. Resistance shall be measured by the linear resistance method.
 - 1) A direct current shall be impressed from one end of the test section to the other (test station to test station) using a DC power supply (battery).
 - 2) A voltage drop is measured through the test section at several current levels. The resistance (R) is calculated using the equation $R = dV/I$, where dV is the voltage drop and I is the current.
 - 3) The resistance shall be calculated for three or four different current levels.
 - 2. Acceptance:
 - a. Acceptance is reasonable comparison of the measured resistance with the calculated or theoretical resistance.
 - b. The measured resistance shall not exceed the theoretical resistance by more than 130-percent. The theoretical resistance is the sum of the pipe resistance and the bond (wire or clip) resistance.
- D. Anode and Pipe Lead Wire Integrity Tests: Retain certified NACE Cathodic Protection Tester to test all anodes.
- 1. Method: After the pipe and anodes and lead wire trenches are backfilled, each anode lead wire shall be tested for electrical continuity to the anode by measuring the anode's potential with respect to a copper-copper sulfate reference electrode.
 - 2. Acceptance: The measured open circuit potential of the anode shall be a minimum of 1.0 volts, or as specified by the manufacturer and accepted by the District.

END OF SECTION

SECTION 15041

CHLORINATION OF POTABLE WATER MAINS AND SERVICES FOR DISINFECTION

PART 1 GENERAL

1.01 SECTION INCLUDES

- A. Disinfection by chlorination of potable water mains, services, appurtenances, and connections by the following methods:
 - 1. Liquid chlorine solution
 - 2. Sodium hypochlorite

1.02 RELATED REQUIREMENTS

- A. Section 15042, Hydrostatic Testing of Pressure Pipelines

1.03 DEFINITIONS

- A. Liquid chlorine solution: The commercially available form of liquefied elemental chlorine gas (Cl₂)
- B. Sodium hypochlorite: Clear light-yellow liquid solution, typically 12.5-percent concentration, of sodium hypochlorite (NaOCl)

1.04 REFERENCED STANDARDS

- A. American Water Works Association:
 - 1. AWWA B300: Hypochlorites
 - 2. AWWA B301: Liquid Chlorine
 - 3. AWWA C651: Disinfecting Water Mains

1.05 SEQUENCING

- A. Concurrent Testing: Disinfecting the mains and appurtenances, hydrostatic testing, and preliminary retention may run concurrently for the required 24-hour period.
- B. In the event there is leakage, and repairs are necessary, additional disinfection shall be required.

1.06 SUBMITTALS

- A. Action Submittals:
 - 1. Testing plan and schedule
 - 2. Disinfection products
 - 3. Testing equipment
- B. Certified testing results

1.07 QUALITY ASSURANCE

- A. Conform to AWWA C651. Where discrepancies exist between current AWWA C651 and this specification, the more stringent requirements shall govern.

PART 2 PRODUCTS

2.01 LIQUID CHLORINE SOLUTION

- A. Liquid chlorine solution shall be in accordance with the requirements of ANSI/AWWA B301.

2.02 SODIUM HYPOCHLORITE

- A. Sodium hypochlorite shall be in accordance with the requirements of ANSI/AWWA B300.

PART 3 EXECUTION

3.01 DISINFECTION PROCEDURES

- A. General Requirements
 - 1. Chlorinate all water mains, water services, attached appurtenances, connections, and other water facilities before being placed in service or connected to existing facilities.
 - 2. The Contractor shall notify the District two (2) working days prior to chlorination of facilities.
 - 3. All required corporation stops and other plumbing materials necessary for chlorination or flushing of the main shall be installed by and at the expense of the Contractor.
 - 4. All mains shall be thoroughly flushed prior to disinfection.
 - 5. Every service connection served by a main being disinfected shall be tightly shutoff at the curb stop before filling the main for disinfection. Care shall be taken to expel all air from the main and services during the filling operation.

6. Methods of chlorination that may be used are:
 - a. Continuous-feed Method
 - 1) Treated water shall be retained in the system for a minimum of 24 hours and shall contain an initial chlorine concentration of 25 ppm and a chlorine residual of not less than 10 ppm at the end of the retention period in all sections being disinfected.
 - b. Slug Method
 - 1) Water shall be fed slowly into the pipeline with chlorine applied in amounts to produce an initial dosage of not less than 100 ppm.
 - 2) Chlorine shall be applied continuously to develop a solid column, or “slug”.
 - 3) All interior surfaces shall be exposed to a concentration of approximately 100 ppm for at least 3 hours.
 - 4) If concentration drops below 50 ppm at any time, flow shall be stopped; chlorination equipment shall be relocated at the head of the slug and, as flow resumes, chlorine shall be applied to restore the free chlorine in the slug to not less than 100 ppm.
- B. Liquid Chlorine Solution Dosing Requirements
 1. Liquid chlorine solution shall be injected with a solution feed chlorinator and a water booster pump.
- C. Sodium Hypochlorite Dosing Requirements
 1. Sodium hypochlorite should be diluted in water to desired concentration and pumped into the pipeline at a measured rate.

3.02 BACTERIOLOGICAL TESTING

- A. The Contractor is responsible for bacteriological testing.
- B. Provide a clean and disinfected sample port including all necessary appurtenances for the purposes of obtaining the sample.
- C. Bacteriological testing shall be conducted after disinfection and final flushing, and when typical system chlorine residuals are present.
 1. The new main shall be allowed to sit for a minimum of 16 hours without any water use. After the 16 hours, two consecutive acceptable samples from each location shall be collected at a minimum of 15 minutes apart. The sampling tap shall be left running between the sample collections.
 2. The main shall not be flushed again prior to samples being taken.
 3. The number and location of required samples shall be determined by the District.
 4. The samples shall be delivered to an EPA-certified, independent laboratory within six hours.
 5. An EPA-approved bacteriological quality test shall be performed by the laboratory. Certified test results with chain of custody shall be delivered to the District.

- D. All mains must successfully pass bacteriological tests prior to connecting to the existing system.
 - 1. Results of satisfactory test shall demonstrate the absence of coliform organisms and a plate count of less than 500 CFU/mL from each sample location.
 - 2. If the tests are not satisfactory, the Contractor shall provide additional disinfection as required.
 - 3. Retesting of the system may be required if 90 days or more have passed between the date of testing and acceptance by the District.
- E. The District reserves the right to perform their own sample collection and testing to validate any test results, as they see necessary. The District-obtained test results shall govern the determination of pipeline acceptability.

3.03 FLUSHING

- A. After chlorination, the water shall be flushed from the line, at its extremities until the replacement water tests are equal chemically and bacteriologically to those of the permanent source of supply.
- B. The chlorinated water may be used later for testing other lines, or if not so used, shall be disposed of by the Contractor. This flushing water shall be discharged to a sanitary sewer. Discharge to the storm drain or watercourse requires acceptance by the District.
- C. The Contractor shall be responsible for all costs to dechlorinate the water before it enters any storm drain or watercourse. The District will not be responsible for loss or damage resulting from such disposal.

3.04 CUTTING INTO EXISTING MAINS

- A. Following the opening of an existing potable water main, the interior of all accessible pipes and fittings shall be swabbed with a 1-percent hypochlorite solution. The drained portion of the existing line and any new section shall be flushed from two directions toward the cut-in, if possible.

END OF SECTION

SECTION 15042

HYDROSTATIC TESTING OF PRESSURE PIPELINES

PART 1 GENERAL

1.01 SECTION INCLUDES

- A. Hydrostatic leakage testing of new or rehabilitated pressure pipelines

1.02 RELATED REQUIREMENTS

- A. Section 02223, Trenching, Backfilling, and Compacting
- B. Section 15041, Chlorination of Potable Water Mains and Services for Disinfection

1.03 DEFINITIONS

- A. Working Pressure: Maximum anticipated sustained operating pressure

1.04 REFERENCE STANDARDS

- A. American Water Works Association (AWWA)
 - 1. AWWA C600: Installation of Ductile Iron Water Mains and Their Appurtenances
 - 2. AWWA C604: Installation of Buried Steel Water Pipe - 4 In. (100 mm) and Larger
 - 3. AWWA C605: Underground Installation of Polyvinyl Chloride (PVC) and Molecularly Oriented Polyvinyl Chloride (PVCO) Pressure Pipe and Fittings

1.05 SEQUENCING

- A. Requirements Prior to Testing:
 - 1. Before testing, the pipe trench shall be backfilled and compacted to the ground surface per Section 02223.
 - 2. All concrete anchor blocks shall be allowed to cure a sufficient time to develop a minimum strength of 2,000 psi, but not less than five (5) days, before testing, unless otherwise directed by the District.
 - 3. Steel pipelines shall not be tested before the mortar lining and coating on all of the pipe lengths in the line have attained an age of 14 days. Cement-mortar lined pipe shall not be filled with water until a minimum period of eight hours has elapsed after the last joint in any section has been made.
 - 4. All surrounding utilities shall be installed prior to testing.
- B. Connection to Existing Mains: Complete hydrostatic testing before connecting new pipelines with existing pipelines.

- C. Final Pavement: All pipeline shall be satisfactorily pressure tested prior to the placement of final pavement.
- D. Disinfection: Disinfecting of pipelines may occur concurrently with hydrostatic testing.

1.06 SUBMITTALS

- A. Action Submittals:
 - 1. Testing plan and schedule
 - 2. Testing equipment, pumps, gauges, and meters
 - 3. Meter and gauge calibration certification
- B. Certified testing results

1.07 QUALITY ASSURANCE

- A. Conform to requirements of the following standards depending on the pipeline material. Where discrepancies exist between the current AWWA standards and this specification, the more stringent requirements shall govern.
 - 1. Ductile iron pipe: AWWA C600
 - 2. Steel pipe: AWWA C604
 - 3. PVC pipe: AWWA C605
- B. Testing Company
 - 1. All testing shall be performed by a District-approved testing company.
 - 2. Tester will have a gauge and meter, calibrated annually.

PART 2 PRODUCTS

2.01 WATER

- A. The same water used for chlorination of the pipeline may be used to fill the line for pressure testing.
- B. Make up water for testing shall be potable water.

PART 3 EXECUTION

3.01 TEST PROCEDURES

- A. Fill pipeline test section with water while purging all air.
- B. For cement mortar lined pipe, allow water to stand for at least 24 hours to permit maximum absorption of water by the lining. Additional makeup water shall be added to replace water absorbed by the lining.

- C. Apply test pressure by approved pumping assembly connected to pipe with temporary test bulkheads.
- D. Monitor leakage rate for duration of test by measuring the required makeup water flow rate to maintain test pressure within allowable variance.

3.02 TEST PRESSURES

- A. Test pressures for pressurized pipelines shall be the greater of the following:
 - 1. 225 psi
 - 2. 50 psi in excess of working pressure
 - 3. As required to ensure pressure at highest elevation of the test section is at least 1.5 times the working pressure
- B. Hydrostatic test pressures at any point in the section tested shall not exceed the following:
 - 1. Design pressure capacity of pipe and appurtenances
 - 2. Design capacity of thrust restraints
- C. Ensure the test pressure variance is less than +/- 5 psi for duration of test.

3.03 TEST DURATION

- A. Perform hydrostatic leakage test for a minimum duration of four hours.

3.04 PIPELINE FILLING

- A. Filling velocity: The pipeline should be filled at a rate such that the average velocity of flow is less than 1-foot per second. At no time shall the maximum velocity of flow exceed 2-feet per second. For convenience, the following table has been provided to relate the velocity of 1-foot per second to an equivalent volume flow rate.

Normal Pipe Diameter (inches)	Flow Rate (gallons per minute)
4	38
6	88
8	158
12	353
16	624

- B. Air Removal:
 - 1. All air should be purged from the pipeline before checking for leaks or performing pressure or acceptance tests on the system.
 - 2. To accomplish this, if air valves or hydrants or other outlets are not available, corporation cocks shall be installed at the high points to expel the air, and these cocks shall be tightly closed afterwards. If allowed by the District, air may be purged using temporary blow-offs at the end of the lines at the test bulkhead.

3.05 ALLOWABLE LEAKAGE RATES

A. Ductile Iron Pipe:

$$L = (S \times D \times P^{1/2}) / (133,200)$$

Where:

L = Allowable leakage rate (makeup water flow rate), in gallons per hour

S = Length of pipe tested, in feet

D = Nominal diameter of pipe, in inches

P = Average test pressure during hydrostatic test, in gauge pound per square inch (psig)

B. Steel and PVC Pipe:

$$L = (N \times D \times P^{1/2}) / (7,400)$$

Where:

L = Allowable leakage rate (makeup water flow rate), in gallons per hour

N = Number of joints (not including welded joints) in pipeline tested, in feet

D = Nominal diameter of pipe, in inches

P = Average test pressure during hydrostatic test, in gauge pound per square inch (psig)

C. Flanged, grooved, and welded joints shall have zero leakage.

3.06 REPAIR

A. Any noticeable leak shall be stopped and all defective pipe, fittings, valves, and other accessories discovered in consequence of the test shall be removed and replaced by the Contractor with sound material.

B. Repeat test until the pipeline meets the testing requirements.

END OF SECTION

SECTION 15043

TESTING OF NON-PRESSURE SEWER PIPELINES AND MANHOLES

PART 1 GENERAL

1.01 SECTION INCLUDES

- A. Low-pressure air test of sewer pipelines
- B. Infiltration testing of sewer pipelines
- C. Deflection testing of sewer pipelines
- D. Leakage testing of manholes

1.02 RELATED REQUIREMENTS

- A. Section 03461, Precast Reinforced Concrete Manholes
- B. Section 15066, Gravity Sewer Pipelines
- C. Section 15068, Sewer Laterals

1.03 REFERENCED STANDARDS

- A. ASTM International:
 - 1. ASTM C828: Standard Test Method for Low-Pressure Air Test of Vitrified Clay Pipe Lines
 - 2. ASTM C1244: Standard Test Method for Concrete Sewer Manholes by the Negative Air Pressure (Vacuum) Test Prior to Backfill
 - 3. ASTM F1417: Standard Practice for Installation Acceptance of Plastic Non-pressure Sewer Lines Using Low-Pressure Air

1.04 QUALITY ASSURANCE

- A. Conform to requirements of the following standards depending on the pipeline material. Where discrepancies exist between the current standards and this specification, the more stringent requirements shall govern.
 - 1. Vitrified Clay Pipe: ASTM C828
 - 2. PVC Pipe: ASTM F1417

PART 2 PRODUCTS (NOT USED)

PART 3 EXECUTION

3.01 GENERAL

- A. General:
 - 1. The Contractor shall furnish all equipment and materials required for testing.
 - 2. All tests shall be made in the presence of the District. No one shall be allowed in the manholes during testing because of the hazards present.
- B. Leakage: Each section of sewer between two successive manholes shall be tested for leakage and the leakage test shall be made on all sections of sewer.
- C. Infiltration: The infiltration test shall be made where excessive groundwater is encountered.
- D. Retesting: Even though a section may have previously passed the leakage or infiltration test, each section of sewer shall be tested subsequent to the last backfill compacting operation if, in the opinion of the District, heavy compaction equipment or any of the operations of the Contractor or others may have damaged or affected the structural integrity or water tightness of the pipe, structure, and appurtenances.
- E. Other Utilities: Official District tests will not be made until after all the other utilities have been installed and their trench compaction verified.
- F. Excessive Leakage or Infiltration: If the leakage or infiltration rate is greater than the amount specified, the pipe joints shall be repaired or, if necessary, the pipe shall be removed and relaid by the Contractor.
- G. Acceptance: The sewer will not be accepted until the leakage or infiltration rate, as determined by testing, is less than the maximum allowable.
- H. House Laterals: House laterals are not to be connected until after the sewer main has been successfully tested.

3.02 LOW-PRESSURE AIR TEST

- A. Test Section: Each section of sewer between two successive manholes shall be tested by plugging all pipe outlets.
- B. Addition of Air: Air shall be slowly added until the internal pressure is raised to 4.0 pounds per square inch gage (psig). The compressor used to add air to the pipe shall have a blowoff valve set at 5 psig to ensure that at no time the internal pressure in the pipe exceeds 5 psig.
- C. Internal Pressure: The internal pressure of 4 psig shall be maintained for at least two minutes to allow the air temperature to stabilize, after which the air supply shall be disconnected and the pressure allowed to decrease to 3.5 psig.
- D. Pressure Drop: The time in seconds that is required for the internal air pressure to drop from 3.5 psig to 2.5 psig shall be measured and the results compared with the minimum permissible pressure holding times indicated in the following table.
- E. Minimum Pressure Holding Times

1. Vitrified Clay Pipe:

Pipe Diameter (inch)	Time (minutes) per 100 feet of length
6	0.7
8	1.2
10	1.5
12	1.8
15	2.1

2. PVC Pipe:

Pipe Diameter (inch)	Time (minutes) per 100 feet of length
6	5.7
8	7.6
10	9.4
12	11.3
15	14.2

- F. Retest: If the pressure drop from 3.5 psig to 2.5 psig occurs in less time than specified, the pipe shall be repaired and, if necessary, replaced and relaid until the joints and pipe shall hold satisfactorily under this test.

3.03 INFILTRATION TEST

- A. Preparation of Test Section: The end of the sewer at the upper structure shall be closed to prevent the entrance of water, and pumping of groundwater shall be discontinued for at least three days, after which the section shall be tested for infiltration.
- B. Allowable Infiltration Rate: The infiltration shall not exceed 0.025 gpm per inch of diameter per 1,000 feet of main line sewer being tested, not including the length of laterals entering that section.
- C. Excessive Infiltration: Where infiltration in excess of the allowable amount is discovered before completion and acceptance of the sewer, the sewer shall be immediately uncovered and the amount of the infiltration reduced to a quantity within the specified amount of infiltration, before the sewer is accepted.
- D. Individual Leaks: Even if the infiltration is less than the allowable amount, any individual leaks that may be observed shall be stopped as directed by the District.
- E. Completion of Tests: All tests must be completed before the street or trench is resurfaced, unless otherwise directed by the District.

3.04 DEFLECTION TEST

- A. All PVC main line pipe shall be tested for deflection, joint displacement, or other obstruction by passing a rigid mandrel through the pipe by hand.
- B. Conduct deflection test not less than 30 days after completion of the trench backfill, but prior to permanent resurfacing.
- C. The mandrel shall be a full circle cylinder, accepted by the District as to design and manufacture. The circular cross section of the mandrel shall have a diameter as indicated in the following table:

Pipe Diameter (inch)	Minimum Mandrel Diameter (inches)
6	5.31
8	7.09
10	8.84
12	10.51

3.05 NEGATIVE AIR PRESSURE (VACUUM) MANHOLE TEST

- A. Perform test per ASTM C1244 immediately after assembly and prior to backfilling.
 - 1. Draw 10 inches mercury of vacuum on the manhole, close vacuum line valve, and shutoff vacuum pump.
 - 2. Measure time for the vacuum to drop to 9 inches mercury.
 - 3. Minimum test times for the vacuum reading to drop from 10 inches to 9 inches mercury are as follows:

Depth (feet)	48-inch Diameter Manhole	60-inch Diameter Manhole	72-inch Diameter Manhole
	Minimum Test Times (seconds)		
<4	10	13	16
6	15	20	25
8	20	26	33
10	25	33	41
12	30	39	49
14	35	46	57
16	40	52	67
18	45	59	73
20	50	65	81
22	55	72	89
24	59	78	97
26	64	85	105
28	69	91	113
30	74	98	121

- B. All manhole inlets and outlets shall be plugged with approved stoppers or plugs.
- C. If the manhole fails the initial test, necessary repairs shall be made with a non-shrink grout while the vacuum is still being drawn. Cracks longer than two-inches shall be cause for rejection of the casting and no patching shall be allowed. Retesting shall proceed until a satisfactory test is obtained.

END OF SECTION

SECTION 15050

HOT TAP CONNECTIONS

PART 1 GENERAL

1.01 SECTION INCLUDES

- A. Hot tap (system under pressure) connections to existing distribution systems

1.02 RELATED REQUIREMENTS

- A. Section 01045, Existing Facilities
- B. Section 15041, Chlorination of Potable Water Mains and Services for Disinfection
- C. Section 15057, Copper, Brass, and Bronze Pipe Fittings and Appurtenances
- D. Section 15100, Manual Valves

1.03 REFERENCED STANDARDS

- A. American Petroleum Institute (API)
 - 1. API RP 2201: Procedures for Welding or Hot Tapping on Equipment in Service
- B. American Water Works Association
 - 1. AWWA C205: Cement-Mortar Protective Lining and Coating for Steel Water Pipe – 4” (100 mm) and Larger – Shop Applied
 - 2. AWWA C210: Liquid-Epoxy Coating Systems for the Interior and Exterior of Steel Water Pipelines
 - 3. AWWA C213: Fusion-Bonded Epoxy Coating for the Interior and Exterior of Steel Water Pipelines
 - 4. AWWA M11: Steel Water Pipe: A Guide for Design and Installation
- C. NSF International
 - 1. NSF 61: Drinking Water Systems Components – Health Effects

1.04 SUBMITTALS

- A. Hot tap connection plan
- B. Product data sheets
- C. Contractor hot tap project list with contact information for agencies/owners

1.05 QUALITY ASSURANCE

- A. Conform to requirements of API RP 2201.
- B. Hot Tapping Company
 - 1. All hot tapping shall be performed by a District-approved hot tapping company.

PART 2 PRODUCTS

2.01 SERVICE SADDLES AND CORPORATION STOPS

- A. Service saddles and corporation stops shall comply with Section 15057.

2.02 TAPPING SLEEVES

- A. Type:
 - 1. Tapping sleeves for tap diameters smaller than the pipeline diameter: full circle type bolted stainless steel
 - 2. Tapping sleeves for size on size taps:
 - a. Full circle cast iron with mechanical joint end glands
 - b. Interior and exterior epoxy coating per:
 - 1) AWWA C210 or AWWA C213
 - 2) Conform to requirements of NSF 61 for interior coatings.
 - 3. Tapping sleeves onto 14-inch and larger ACP:
 - a. Full circle cast iron with mechanical joint end glands
 - b. Interior and exterior epoxy coating per:
 - 1) AWWA C210 or AWWA C213
 - 2) Conform to requirements of NSF 61 for interior coatings.
- B. Gaskets: Buna-N rubber with a wide cross section
- C. Bolts and trim hardware: Type 316 stainless steel

2.03 TAPPING VALVES

- A. Tapping valves shall be flanged resilient seat wedge gate valves per Section 15100.
- B. All bolts and trim hardware shall be Type 316 stainless steel.

2.04 WELD NOZZLES

- A. Weld nozzles and reinforcing plates shall be fabricated steel per AWWA M11.

PART 3 EXECUTION

3.01 NOTIFICATION

- A. The Contractor shall provide proper notification to the District inspector at least five working days prior to making a hot tap connection.

3.02 VERIFICATION

- A. The Contractor shall pothole the proposed connection to verify the outside diameter, location and type of pipe to be tapped prior to ordering materials.

3.03 SURFACE PREPARATION

- A. The pipe barrel to be tapped shall be thoroughly cleaned with a wire brush to provide a smooth, hard surface for the saddle, sleeve or nozzle.

3.04 SERVICE SADDLE AND CORPORATION STOP

- A. Service saddles and corporation stops will be installed onto ACP, DIP or PVC mains in accordance with the manufacturer's instructions and Section 15057. The outlet shall be oriented to comply with the intended use of the service connection.

3.05 WELD NOZZLES

- A. Nozzles and reinforcing plates are to be welded onto steel pipe shells in accordance with API RP 2201.

3.06 TAPPING SLEEVES

- A. The tapping sleeve shall be installed in accordance with the manufacturer's instructions and to the satisfaction of the District.
- B. The pipe barrel shall be thoroughly cleaned with a wire brush to provide a smooth, hard surface for the sleeve.
- C. The sleeve shall be supported independent of the pipe during the tapping operation.
- D. The sleeve shall be hydrostatically tested in the presence of the District prior to tapping.
- E. Thrust blocks shall be provided at the tapping sleeve.

3.07 TAPPING VALVE

- A. The tapping valve shall be installed on the tapping sleeve or weld nozzle per Section 15100.

3.08 HOT TAP

- A. All taps into existing pipes will be made through a service saddle, tapping sleeve, welded nozzle or welded coupling. Direct taps are not permitted.

- B. The hot tap into the existing pipe shall be made using the appropriate type of cutting machine and shell cutting bit for the material being tapped.
- C. The tapping machine shall be operated per the manufacturer's operating instructions.
- D. Proper care shall be taken to prevent cutting material from entering the pipeline. The tapping coupon must be extracted.

3.09 MORTAR COATING REPAIR

- A. The exterior mortar coating on welded steel pipe shall be repaired in accordance with AWWA C205.

3.10 TESTING

- A. Perform hydrostatic test of hot tap installation in the presence of the District inspector prior to tapping the pipe.
- B. Test pressure:
 - 1. At least equal to the operating pressure of the line to be tapped
 - 2. Not exceeding the present internal pressure by more than approximately 10 percent, in order to avoid possible internal collapse of the pipe or vessel wall

3.11 DISINFECTION

- A. The interior of the tapping valve and connecting piping shall be sprayed with a 1-percent sodium hypochlorite solution prior to connection per requirements of Section 15041.

END OF SECTION

SECTION 15056

DUCTILE-IRON PIPE AND FITTINGS

PART 1 GENERAL

1.01 SECTION INCLUDES

- A. Ductile-iron pipe and fittings

1.02 RELATED REQUIREMENTS

- A. Section 02223, Trenching, Backfilling, and Compacting
- B. Section 03300, Concrete
- C. Section 09900, Painting and Coating
- D. Section 13121, Corrosion Protection
- E. Section 15041, Chlorination of Potable Water Mains and Services for Disinfection
- F. Section 15042, Hydrostatic Testing of Pressure Pipelines

1.03 REFERENCED STANDARDS

- A. AWWA C104: Cement-Mortar Lining for Ductile-Iron Pipe and Fittings
- B. AWWA C105: Polyethylene Encasement for Ductile-Iron Pipe Systems
- C. AWWA C110: Ductile-Iron and Gray-Iron Fittings
- D. AWWA C111: Rubber-Gasket Joints for Ductile-Iron Pressure Pipe and Fittings
- E. AWWA C150: Thickness Design of Ductile-Iron Pipe
- F. AWWA C151: Ductile-Iron Pipe, Centrifugally Cast
- G. AWWA C153: Ductile-Iron Compact Fittings
- H. AWWA C600: Installation of Ductile-Iron Water Mains and Their Appurtenances
- I. ASTM A193: Standard Specification for Alloy-Steel and Stainless Steel Bolting for High Temperature or High Pressure Service and Other Special Purpose Applications
- J. ASTM A194: Standard Specification for Carbon Steel, Alloy Steel, and Stainless Steel Nuts for Bolts for High Pressure or High Temperature Service, or Both
- K. ASTM A536: Standard Specification for Ductile-Iron Castings

1.04 SUBMITTALS

- A. Product data sheets
- B. Thrust restraint calculations

PART 2 PRODUCTS

2.01 DUCTILE-IRON PIPE

- A. Pressure class or thickness class of DIP shall be determined by the design method detailed in AWWA C150 the "Thickness Design Method."
- B. Ductile-iron pipe shall be manufactured in accordance with AWWA C151.
- C. All ductile-iron pipe shall be the pressure class shown on the plans for bell and spigot pipe, pressure Class 350 for plain end pipe and thickness, and Class 53 for flanged spools unless indicated otherwise.
- D. Lining:
 - 1. Potable and recycled water: Cement-mortar lined in accordance with AWWA C104. Lining thickness shall be the double thickness listed in AWWA C104.
 - 2. Sewer: Ceramic epoxy lining
- E. Coating:
 - 1. Buried: factory applied bituminous coating of not less than 1 mil. in thickness
 - 2. Non-buried: primer coat suitable for use with coating system in Section 09900.
- F. Unless otherwise called out on the plans, a push-on type joint shall be used. The joint dimensions and gasket shall be as specified in AWWA C111.
- G. Where restrained joints are called for, provide the following:
 - 1. Restraint harness system for push-on joints:
 - a. Design: Ductile-iron pipe bell restraint system consisting of a wedge action restraint ring on the spigot joined to a split ductile-iron ring behind the bell. Restraint ring incorporates individually actuated wedges. Proper actuation of the wedges achieved through use of torque limiting twist off nuts.
 - b. Design safety factor: 2.0
 - c. Restraint ring and wedging components: Cast iron per ASTM A536, grade 65-45-12
 - d. Gripping wedges: Heat treated ductile-iron with minimum hardness of 370 BHN
 - e. Coating: Fusion bonded polyester, 5 mil thickness
 - f. Restraining rods and clamping fasteners: Type 316 Stainless steel
- H. Flanges for ductile-iron pipe shall be in accordance with AWWA C115.

I. Outlets for DIP shall be as follows:

2" or smaller:	bronze service saddle
2-1/2":	tapped tee or service saddle
4" and larger:	ductile-iron tee fitting

2.02 DUCTILE-IRON FITTINGS

- A. Ductile-iron fittings shall be manufactured in accordance with AWWA C110, or AWWA C153. Compact body fittings, as described in AWWA C153, will not be permitted in vault structures.
- B. Lining: Same as ductile-iron pipe
- C. Coating: Same as ductile-iron pipe
- D. All fittings shall be made with "push-on" joints designed for use with the type of pipe to be joined unless noted otherwise.
- E. Where restrained joints are called for, provide the following:
 - 1. Mechanical joint restraining gland:
 - a. Design: Restraint device consisting of multiple gripping lugs/wedges/pads around the pipe circumference incorporated into a follower gland meeting the applicable requirements of AWWA C110.
 - 1) Specifically designed for the pipe material being connected to coupling
 - 2) Proper actuation of the gripping wedges achieved through use of torque limiting twist off nuts.
 - b. Design safety factor: 2.0
 - c. Gland: Cast iron per ASTM A536, grade 65-45-12
 - d. Gripping lugs/wedges/pads: Heat treated ductile-iron
 - e. Coating: Fusion bonded polyester, 5 mil thickness
 - f. Tie bolts: Type 316 Stainless steel
- F. Unless otherwise indicated on the drawings, all fittings with flanged ends shall be ductile-iron class 150. The gasket surface shall have a serrated finish of approximately 16 serrations per inch, approximately 1/32-inch deep, with serrations in either a concentric or spiral pattern. All flanges shall be flat faced. In addition, all flanges shall meet the following tolerances:

Bolt circle drilling	$\pm 1/16$ inch
Bolt hole spacing	$\pm 1/32$ inch
Eccentricity of bolt circle and	$\pm 1/32$ inch
Maximum facing with respect to bore	
- G. Gray-iron fittings may not be substituted for ductile-iron.

2.03 GASKETS

- A. Flange Gaskets:
 - 1. Gaskets for flanged joints shall be 1/8-inch thick, synthetic-fiber rubber.
 - 2. Full face type gaskets with pre punched holes shall be used where both flanges are flat face. Ring gaskets extending to the inner edge of the bolts may be used where a raised face flange is present.
- B. Push on or mechanical joint gaskets: Rubber gaskets for push on joints shall be synthetic or natural rubber manufactured in accordance with AWWA C111.

2.04 HARDWARE

- A. All bolts and nuts shall be Type 316 stainless steel conforming to ASTM A 193, Grade B8M for bolts, and ASTM A 194, Grade 8M for nuts.
- B. Provide one (1) washer for each nut. Washer shall be of the same material as the nuts.
- C. The length of each bolt or stud shall be such that between 1/4 inch and 3/8 inch will project through the nut when drawn tight.
- D. Tie-bolts for restrained joints shall be Type 316 stainless steel.

2.05 CORROSION GUARD

- A. Water resistant, oxidation inhibiting cosmoline grease or microcrystalline wax-based coating system that adheres to metal surfaces
- B. 345-degree F dropping point

2.06 LUBRICANTS

- A. Lubricant for pipe insertion shall be food grade, and biodegradable.

PART 3 EXECUTION

3.01 GENERAL

- A. Ductile-iron pipe and ductile-iron fittings shall be installed in accordance with the applicable Sections of AWWA C600 and as specified herein.
- B. Where the pipe grade is not shown, the minimum allowable pipe cover is listed below. The pipe grade shall be accepted by the District.
 - a. Distribution Mains (12-inch diameter and smaller): The top of the pipe is to be a minimum of 42 inches below finished grade.
 - b. Transmission Mains (larger than 12-inch diameter): The top of the pipe is to be a minimum of 48 inches below finished grade.

- C. Coat buried stainless steel hardware with corrosion guard. Exposed stainless steel hardware shall not be coated.

3.02 TRENCHING, BACKFILLING, AND COMPACTING

- A. Trenching, backfilling, and compacting shall be in accordance with Section 02223 and as specified herein.

3.03 PLACEMENT OF PIPE IN TRENCH

- A. Lay pipes uphill if the grade exceeds 10-percent.
- B. The radius of curvature of the trench shall determine the maximum length of pipe section that can be used without exceeding the allowable deflection at a joint. Combined deflections at rubber gasket, restrained joint, deflection coupling or flexible coupling joints shall not exceed 50-percent of the manufacturer's recommended deflection.
- C. The manufacturer's printed installation guide outlining the radius of curvature that can be negotiated with pipe sections of various length and the deflection couplings shall be followed if applicable.
- D. The pipe shall be laid true to the line and grade shown on the plans within acceptable tolerances. The tolerance on grade is 1 inch. The tolerance on line is 2 inches.
- E. Fittings shall be supported independently of the pipe.
- F. Until thrust blocks and supports are poured, fittings shall be temporarily supported by placing sand under the bells so that the pipe is not subjected to the weight of the fitting.
- G. Bond all pipe joints with bond wire per Section 13121.

3.04 EXTERIOR PROTECTION

- A. Exterior surface, buried service:
 - 1. Wrap buried valves with 8-mil polyethylene wrap per AWWA C105. Wrap beyond valve by 12 inches on both sides. Wrap all joints in polyethylene wrap with 2-inch wide polyethylene adhesive tape.
 - 2. Apply corrosion guard to all hardware.
- B. Exterior surface, non-buried: Coat all surfaces per Section 09900.

3.05 THRUST RESTRAINT

- A. Construct thrust blocks at all pipe deflection angles greater than 5 degrees, at changes in pipe size, at fittings, at hydrant ells, and at valves.
- B. Install pipe with restrained joints only where shown on the Drawings, or where directed by the District.
- C. Design thrust restraint method used (thrust blocks, restrained joints, etc.) to withstand the maximum internal pipeline pressure created during testing of each particular pipeline.

- D. The area and design of the bearing surface shall be per the Drawings. Submit thrust restraint calculations where soil or pressure parameters differ than as shown on the Drawings.
- E. The bearing surface shall be against wetted undisturbed ground in all cases, except where unstable conditions are encountered. In unstable conditions, the bearing surface shall be as directed by the District.
- F. Unless otherwise directed by the District, the blocking shall be placed so that the pipe and fitting joints are accessible for repair.
- G. The depth of thrust blocks below valves shall conform with the size of the valve and shall be cut into the side of the trench a minimum of 12-inches on each side.

3.06 FLANGED CONNECTIONS

- A. Bolt holes of flanges shall straddle the horizontal and vertical centerlines of the pipe run.
- B. Clean flanges by wire brushing before installing gaskets.
- C. Clean flange bolts and nuts by wire brushing, lubricate threads with anti-seize compound, and tighten nuts uniformly and progressively. Between 1/4 inch and 3/8 inch shall project through the nut when drawn tight.
- D. If flanges leak under pressure testing, loosen or remove the nuts and bolts, reseal or replace the gasket, reinstall or retighten the bolts and nuts, and retest the joints. Joints shall be watertight.

3.07 PIPE SUPPORT

- A. All exposed pipe shall be supported as detailed in the plans.

3.08 DISINFECTION

- A. All potable water piping shall be disinfected by chlorination in accordance with Section 15041.

3.09 TESTING

- A. All potable water and recycled water piping shall be hydrostatically pressure tested in accordance with Section 15042.

END OF SECTION

SECTION 15057

COPPER, BRASS, AND BRONZE PIPE FITTINGS AND APPURTENANCES

PART 1 GENERAL

1.01 SECTION INCLUDES

- A. Copper tubing and fittings
- B. Brass pipe, nipples, and fittings
- C. Brass corporation and angle meter stops, and appurtenances
- D. Bronze saddles and appurtenances

1.02 RELATED REQUIREMENTS

- A. Section 02223, Trenching, Backfilling, and Compacting
- B. Section 13110, Dissimilar Metal Connections
- C. Section 15151, Potable Water, Recycled Water, and Wastewater Facilities Identification

1.03 REFERENCED STANDARDS

- A. ASTM International
 - 1. ASTM A193: Standard Specification for Alloy-Steel and Stainless Steel Bolting for High Temperature of High Pressure Service and Other Special Purpose Applications
 - 2. ASTM A194: Standard Specification for Carbon Steel, Alloy Steel, and Stainless Steel Nuts for Bolts for High Pressure or High Temperature Service, or Both
 - 3. ASTM B32: Standard Specification for Solder Metal
 - 4. ASTM B43: Standard Specification for Seamless Red Brass Pipe, Standard Sizes
 - 5. ASTM B75: Standard Specification for Seamless Copper Tube
 - 6. ASTM B88: Standard Specification for Seamless Copper Water Tube
 - 7. ASTM F467: Standard Specification for Nonferrous Nuts for General Use
 - 8. ASTM F468: Standard Specification for Nonferrous Bolts, Hex Cap Screws, Socket Head Cap Screws, and Studs for General Use
- B. American Water Works Association
 - 1. AWWA C800: Underground Service Line Valves and Fittings
- C. NSF International
 - 1. NSF 61: Drinking Water Systems Components – Health Effects

- D. ASME Boiler and Pressure Vessel Code

1.04 SUBMITTALS

- A. Submit detailed layout if pipe runs in copper exceed 50 linear feet.
- B. Submit catalog order sheets showing material construction and conformance to industry standards (ASTM, etc.) specified. The material data sheets shall indicate NSF certification for materials used on the potable water system.

PART 2 PRODUCTS

2.01 COPPER TUBING AND FITTINGS

- A. Copper tubing shall conform to the requirements of ASTM B88 for seamless copper water tube. Piping located aboveground or suspended within vaults shall be Type L. Buried piping shall be Type K. Copper pipe shall be of domestic manufacture.
- B. Fittings shall be copper conforming to ASTM B75 and ANSI B16.22, with solder end joints. Fittings 3/8 inch and smaller may have flared end connections or compression joint connections.
- C. Solder shall be silver solder conforming to ASTM B32, Grade 95TA. Do not use cored solder.
- D. All copper lines shall be encased within a 8-mil polyethylene sleeve. Sleeves shall be color coded per Section 15151.
- E. Conform to NSF 61.

2.02 BRASS PIPE, NIPPLES, AND FITTINGS

- A. Short threaded nipples, brass pipe, and fittings shall conform to ASTM B43, regular wall thickness, except for nipples and pipe of sizes 1-inch and smaller shall be extra strong. Threads shall conform to ANSI B2.1.
- B. Conform to NSF 61.

2.03 BRASS APPURTENANCES

- A. General: All items specified herein shall be manufactured of brass conforming to AWWA C800 and NSF 61.
- B. Customer service valves:
 - 1. Ball valve type and shall be manufactured of brass, with lever-type turn handle.
 - 2. Inlet connection: Meter flange or a meter coupling
 - 3. Outlet connection: Female iron pipe thread
- C. Corporation stops: Ball valve type and shall be manufactured of brass. The inlet fitting shall be a male iron pipe thread when used with saddle and the outlet connection shall be a flare type.

- D. Angle meter stops: Ball valve type for 3/4-inch and 1-inch services and ground inverted key type for 1-1/2-inch and 2-inch services and shall be manufactured of brass. The inlet connection shall be a flare type or female iron-pipe thread and the outlet fitting shall be a meter flange or meter coupling. The inlet and outlet shall form an angle of 90 degrees on a vertical plane through the centerline of the meter stop. A rectangular lug and lock wing shall be provided on the top of the fitting to operate the shutoff mechanism.

2.04 BRONZE APPURTENANCES

A. General:

- 1. All items specified herein shall be manufactured of bronze conforming to AWWA C800 and NSF 61.

B. Saddles:

- 1. Design:
 - a. Double-strap with flat straps (or bails)
 - b. Tapped for an iron pipe thread
 - c. The seal with the pipe shall be effected with either a rubber gasket or an O-ring.
- 2. Material
 - a. Straps (or bails):
 - 1) Silicon bronze for tapping asbestos cement pipe
 - 2) Type 316 stainless steel for tapping C900 PVC and ductile iron pipe
 - b. Body: Bronze
- 3. Flanges, Gaskets, Bolts, and Nuts

C. Flanges:

- 1. Connect to flanged valves and fittings with bronze flanges conforming to ANSI B16.24, Class 125 or Class 150, to match the connecting flange. Use solder end companion flanges.
- 2. Gaskets for flanged-end fittings shall be made of synthetic rubber binder and shall be fullface, 1/8-inch-thick.
- 3. When both adjoining flanges are bronze, use bronze bolts and nuts. Bolts shall conform to ASTM F468, Grade C65100 or C63000. Nuts shall conform to ASTM F467, Grade C65100 or C63000.
- 4. When only one of the adjoining flanges is bronze, use type 316 stainless-steel bolts and nuts conforming to ASTM A193, Grade B8M for bolts, and ASTM A194, Grade 8M for nuts.
- 5. Connect to buried ferrous flanges with flange insulation kits. Bolts used in flange insulation kits shall conform to ASTM A193, Grade B7. Nuts shall comply with ASTM A194, Grade 2H. If the adjoining buried flange is bronze, use bronze bolts and nuts as described above, without a flange insulation kit.
- 6. Provide one (1) washer for each nut. Each washer shall be of the same material as the nut.

PART 3 EXECUTION

3.01 COPPER TUBING AND FITTINGS

- A. Cut tubing square and remove burrs. Clean both the inside and outside of fitting and pipe ends with steel wool and muriatic acid before soldering. Prevent annealing of fittings and tubing when making connections. Do not miter joints for elbows or notch straight runs of pipe for tees.
- B. Bends in soft copper tubing shall be long sweep. Shape bends with shaping tools. Form bends without flattening, buckling, or thinning the tubing wall at any point.
- C. Brazing procedures shall be in accordance with Articles XII and XIII, Section IX, of the ASME Boiler and Pressure Vessel Code. Silver solder shall be used. Solder shall penetrate to the full depth of the cup in joints and fittings. Solderers shall comply with ANSI B31.3, paragraph 328.
- D. Buried piping shall be installed with some slack to provide flexibility in the event of a load due to settlement, expansion or contraction. A minimum cover of 36 inches below the finished street grade shall be adhered to. The tubing is to be bedded and covered with sand or select material as determined by the District.
- E. All potable service laterals shall be 3/4-inch minimum size copper tubing. End connections shall be flare type.
- F. All 2-inch size services shall be installed with straight lengths of soft copper water tube Type K. Flare fittings are acceptable on only the corporation stop and angle meter stop. All couplings and adapters shall be silver soldered.
- G. The service line shall extend perpendicular to the centerline of the street from the water main to the meter stop or structure, except in a cul-de-sac, where the service shall run in a straight line from the water main to the meter stop.
- H. The service line shall be placed within an 8-mil polyethylene sleeve, color-coded for the type of service. The ends and splices in the sleeve shall be sealed with 20-mil tape.

3.02 SERVICE SADDLE

- A. The service saddle shall be no closer than 18 inches to a valve, coupling, joint, or fitting.
- B. The surface of the pipe shall be filed to remove all loose material and to provide a hard, clean surface before placing the service saddle.
- C. The service saddle shall be tightened per manufacturer's recommendation. Care shall be used to prevent damage or distortion of either the corporation stop or service saddle by over tightening.
- D. The tap into the pipe shall be made in accordance with the pipe manufacturer's recommendation.

3.03 INSTALLING FLANGE BOLTS AND NUTS

- A. Lubricate bolt threads with anti-seize compound prior to installation.

- B. Set flanged pipe with the flange bolt holes straddling the pipe horizontal and vertical centerlines.

3.04 DISSIMILAR METALS

- A. Isolate dissimilar metals per Section 13110.

3.05 BACKFILL MATERIAL

- A. The pipe zone material for all service laterals shall be compacted sand per Section 02223.

END OF SECTION

SECTION 15064

PVC PRESSURE DISTRIBUTION PIPE

PART 1 GENERAL

1.01 SECTION INCLUDES

- A. Polyvinyl chloride (PVC) pressure distribution pipe

1.02 RELATED REQUIREMENTS

- A. Section 02223, Trenching, Backfilling, and Compacting
- B. Section 03300, Concrete
- C. Section 15041, Chlorination of Potable Water Mains and Services for Disinfection
- D. Section 15042, Hydrostatic Testing of Pressure Pipe
- E. Section 15050, Hot Tap Connections
- F. Section 15056, Ductile-Iron Pipe and Fittings
- G. Section 15100, Manual Valves
- H. Section 15151, Potable Water, Recycled Water, and Wastewater Facilities Identification

1.03 REFERENCED STANDARDS

- A. American Water Works Association
 - 1. AWWA C110: Ductile-Iron and Gray-Iron Fittings
 - 2. AWWA C153: Ductile-Iron Compact Fittings
 - 3. AWWA C210: Liquid-Epoxy Coating Systems for the Interior and Exterior of Steel Water Pipelines
 - 4. AWWA C213: Fusion-Bonded Epoxy Coating for the Interior and Exterior of Steel Water Pipelines
 - 5. AWWA C900: Polyvinyl Chloride (PVC) Pressure Pipe and Fabricated Fittings, 4 In. Through 12 In., for Water Transmission and Distribution
 - 6. AWWA C905: Polyvinyl Chloride (PVC) Pressure Pipe and Fabricated Fittings, 14 In. through 48 In., for Water Transmission and Distribution

1.04 SUBMITTALS

- A. Product data sheets
- B. Thrust restraint calculations

1.05 QUALITY ASSURANCE

- A. Conform to AWWA C900 unless noted otherwise below.

PART 2 PRODUCTS

2.01 PVC PIPE

- A. PVC pipe shall be manufactured in accordance with AWWA C900. The pipe shall have gasket bell end or plain end with elastomeric gasket coupling.
- B. Laying lengths shall be 20 feet with the manufacturer's option to supply up to 15-percent random (minimum length 10 feet).
- C. Each pipe length shall be marked showing the nominal pipe size and O.D. base, the AWWA pressure class, and the AWWA specification designation (AWWA C900). For potable water application, the seal of the testing agency that verified the suitability of the material for such service shall be included.
- D. Pipe for recycled lines shall be purple in color and marked as detailed in Section 15151.
- E. Where restrained joints are called for, provide the following:
 - 1. Restraint harness system for push-on joints:
 - a. Design: Ductile-iron pipe bell restraint system consisting of a wedge action restraint ring on the spigot joined to a split ductile-iron ring behind the bell. Restraint ring incorporates individually actuated wedges. Proper actuation of the wedges achieved through use of torque limiting twist off nuts.
 - b. Design safety factor: 2.0
 - c. Restraint ring and wedging components: Cast iron per ASTM A536, grade 65-45-12
 - d. Gripping wedges: Heat treated ductile-iron with minimum hardness of 370 BHN
 - e. Coating: epoxy per AWWA C210 or AWWA C213
 - f. Restraining rods and clamping fasteners: Type 316 Stainless steel

2.02 FITTINGS

- A. Fittings shall be ductile-iron conforming to Section 15056.

2.03 LUBRICANTS

- A. Lubricant for pipe insertion shall be food grade, and biodegradable.

2.04 LOCATOR WIRE

- A. No. 10 AWG copper wire with insulating suitable for direct burial
- B. The insulation shall be blue for potable water, purple for recycled water, and green for pressurized sewer lines.

PART 3 EXECUTION

3.01 GENERAL

- A. The Contractor shall install all the pipe, closure sections, fittings, valves, and appurtenances shown including pipe supports, bolts, nuts, gaskets, and jointing materials.
- B. At all times when the work of installing pipe is not in progress, all openings into the pipe and the ends of the pipe in the trenches or structure shall be kept tightly closed to prevent the entrance of animals and foreign materials. The Contractor shall maintain the inside of the pipe clean, sanitary, and free from foreign materials until its acceptance by the District.
- C. Where closure sections are required by the Contractor's installation operations, the sections shall be installed in accordance with the applicable sections of these specifications.
- D. The pipe sections shall be laid in the trench to true alignment and grade in accordance with the drawings.
- E. Where the pipe grade is not shown, the minimum allowable pipe cover is listed below. The pipe grade shall be accepted by the District.
 - a. Distribution Mains (12-inch diameter and smaller): The top of the pipe is to be a minimum of 42 inches below finished grade.
 - b. Transmission Mains (larger than 12-inch diameter): The top of the pipe is to be a minimum of 48 inches below finished grade.
- F. Curved Pipe Alignments:
 - 1. Limit pipe joint or coupling deflection to 50-percent of manufacturer's published allowable amount.
 - 2. Longitudinal bending of pipe barrel:
 - a. Limit bend radius to no less than 200-percent of manufacturer's published allowable amount.
 - 1) Ensure a constant bend radius is achieved throughout the length of each pipe section and ensure there are no points of a shorter bend radius (i.e. tighter curvature).
 - b. Do not deflect joints when also longitudinally bending the pipe barrel.
 - 1) Implement construction measures to prevent any deflection of the joints when longitudinally bending the pipe barrel.
 - 3. Install couplings or elbow fittings as necessary to achieve greater deflection.

3.02 INSTALLATION

- A. Trenching, backfilling, and compacting shall be in accordance with Section 02223 and as specified herein.
- B. Proper care shall be used to prevent damage in handling, moving, and placing the pipe. Tools and equipment satisfactory to the District shall be provided and used by the Contractor.
- C. The Contractor shall take all necessary precautions to prevent the pipe from floating due to water entering the trench from any source, shall assume full responsibility for any damage due to this cause, and shall pay for and perform the work to restore and replace the pipe to its specified condition and grade if any displacement occurs due to floating.
- D. Excavate bell holes at each joint to permit proper assembly and inspection of the entire joint.
- E. All connecting parts of pipe, rings, couplings, and castings shall be cleaned before assembly. After bearing has been obtained, couplings shall be assembled in a proper manner (as determined by the District). The use of excessive lubricant will not be permitted, and the assembly of the couplings and rings shall be in accordance with the manufacturer's recommendations. Lubricant and rubber rings shall be supplied by the pipe manufacturer. All fittings and valves shall have joints that match the type of adjoining pipe.
- F. All fittings and valves shall be supported so that the pipe is not subjected to the weight of these appurtenances.
- G. Install locating wire above pipe as shown on the Drawings.
 - 1. Bring locating wire to within 6 inches of finish grade at valve locations.
 - 2. Wire shall be accessible by removing the valve can cover. The wire shall be brought up the outside of the valve well and folded over between the inside of the valve can and the valve well.
 - 3. The wire shall not be spliced at any point, and shall be continuous from riser to riser.

3.03 INSTALLATIONS WITHIN JACKED CASING

- A. Certain portions of the project, such as crossings of some roads, highways, and railroads, may be required to be installed within a jacked casing pipe.
- B. Work shall not proceed without permission of the District.
- C. All pipe installed within a casing shall have restrained joints.

3.04 TAPPING

- A. Hot tap connections per Section 15050.

3.05 PIPE IDENTIFICATION

- A. Warning and locator tape and locator wire shall be installed on all on-site recycled water pipelines and potable water piping installed within the limits of a non-potable irrigation system. The pipe identification shall be in accordance with Section 15151.

3.06 LOCATOR WIRE

- A. Install #10 AWG copper wire with insulating suitable for direct burial over the top of the pipe as shown on the Drawings.
- B. The insulation shall be blue for potable water, green for sewer lines, and purple for recycled water.
- C. The wire shall not be spliced at any point, and shall be continuous from riser to riser.
- D. The wire shall be brought to the surface at valve locations and shall be accessible by removing the valve can cover. The wire shall be brought up the outside of the valve well and folded over between the inside of the valve can and the valve well. The wire shall be brought to within 6 inches of finish grade.

3.07 THRUST RESTRAINT

- A. Conform to requirements of Section 15056.

3.08 CHLORINATION

- A. All potable water pipelines shall successfully be chlorinated in accordance with Section 15041 prior to connection to the existing distribution system.

3.09 HYDROSTATIC TESTING

- A. All pipelines shall pass a hydrostatic pressure test in accordance with Section 15042.

END OF SECTION

SECTION 15066

GRAVITY SEWER PIPELINES

PART 1 GENERAL

1.01 SECTION INCLUDES

- A. Gravity sewer pipelines
 - 1. Vitrified clay pipe (VCP)
 - 2. Polyvinyl chloride (PVC) pipe

1.02 RELATED REQUIREMENTS

- A. Section 02223, Trenching, Backfilling, and Compacting
- B. Section 03461, Precast Reinforced Concrete Manholes
- C. Section 15043, Testing of Non-Pressure Sewer Pipelines and Manholes
- D. Section 15068, Sewer Laterals

1.03 REFERENCED STANDARDS

- A. ASTM International
 - 1. ASTM C301: Standard Test Methods for Vitrified Clay Pipe
 - 2. ASTM C425: Standard Specification for Compression Joints for Vitrified Clay Pipe and Fittings
 - 3. ASTM C700: Standard Specification for Vitrified Clay Pipe, Extra Strength, Standard Strength, and Perforated
 - 4. ASTM D395: Standard Test Methods for Rubber Property – Compression Set
 - 5. ASTM D412: Standard Test Methods for Vulcanized Rubber and Thermoplastic Elastomers - Tension
 - 6. ASTM D573: Standard Test Method for Rubber – Deterioration in an Air Oven
 - 7. ASTM D1149: Standard Test Methods for Rubber Deterioration – Cracking in an Ozone Controlled Environment
 - 8. ASTM D1784: Standard Specification for Rigid Poly (Vinyl Chloride) (PVC) Compounds and Chlorinated Poly (Vinyl Chloride) (CPVC) Compounds
 - 9. ASTM D2240: Standard Test Method for Rubber Property – Durometer Hardness
 - 10. ASTM D3034: Standard Specification for Type PSM Poly (Vinyl Chloride) (PVC) Sewer Pipe and Fittings

- B. National Association of Sewer Service Companies (NASSCO)
 - 1. Pipeline Assessment Certification Program (PACP)

1.04 SUBMITTALS

- A. Vitrified Clay Pipe
 - 1. Provide certificates of compliance with all standards referenced in this section to the District.
 - 2. Provide copies of the manufacturer's required tests of the following conducted on project pipe:
 - a. Crushing test
 - b. Record of retests and rejections
- B. PVC Gravity Sewer Pipe
 - 1. Provide materials list showing material of pipe and fittings with ASTM references and grade.
 - 2. Provide certificates of compliance with all standards referenced in this section to the District.
- C. Installation
 - 1. An installation schedule (tabulated layout) shall be submitted which includes:
 - a. Order of installation and closures
 - b. Pipe centerline station and elevation at each change of grade and alignment
 - c. Locations of manholes

1.05 DELIVERY, STORAGE AND HANDLING

- A. Per manufacturer's recommendations and the following:
 - 1. Onsite Storage Limitation: Onsite pipe storage shall be protected from UV exposure and limited to a maximum of one week, unless exception is accepted by the District.
 - 2. Care of Pipe: At times when the pipe laying is not in progress, the open end of the pipe shall be closed with a tight-fitting cap or plug to prevent the entrance of foreign matter into the pipe. These provisions shall apply at all times. In no event shall the sewers be used as drains for removing water which has infiltrated into the construction trenches.
 - 3. Moving Pipe: Pipes shall be lifted with handling beams or wide belt slings as recommended by the pipe manufacturer. Cable slings shall not be used. Pipe shall be handled in a manner to avoid damage to the pipe. Pipe shall not be dropped or dumped from trucks or into trenches under any circumstances.
 - 4. Inspection of Pipe: The pipe and accessories shall be inspected for defects prior to lowering into the trench. Any defective, damaged or unsound pipe in the District's determination shall be replaced at no additional cost to the District. All foreign matter or dirt shall be removed from the interior of the pipe before lowering into position in the trench.

PART 2 PRODUCTS

2.01 VITRIFIED CLAY PIPE (VCP)

- A. General: All VCP and fittings shall be of one class; designated extra strength; of the best quality; vitrified; homogenous in structure; thoroughly burned through their entire thickness; impervious to moisture; sound; and free from cracks, checks, blister, broken extremities, or other imperfections. Pipe shall be bell and spigot pipe unless otherwise specified. Pipe ends shall be square with the longitudinal axis, and sockets shall be true, circular, and concentric with the barrel of the pipe. The thickness of the shell, the depth of the socket, and the dimension of the annular space shall be within the limits of permissible variation to dimension standards of the specifications of ASTM C700, for the size of pipe indicated on the plans.

- B. Pipe Marking: All pipe or fittings shall be clearly marked with the name of the manufacturer or with a trademark and with the size and strength of the pipe as shown on the plans and as herein specified.

- C. Source Testing:
 - 1. Perform factory test of pipes per requirements in ASTM C301.
 - 2. Tests shall be witnessed by a reputable testing laboratory. Pipe selected for testing shall be delivered to the place and at the time designated by the testing laboratory. All costs of furnishing, transporting, and handling the pipe for testing and conducting the tests shall be borne by the Contractor.
 - 3. In lieu of witnessing by a testing laboratory, a certified statement from the pipe manufacturer may be furnished stating that all prescribed tests have been made and the pipe to be used on the project has met all requirements of the specifications.
 - 4. The testing laboratory shall select, at random, for testing as herein specified, no less than 0.5-percent of the number of pipe sections in each size of pipe furnished, except that no less than two specimens shall be tested.
 - 5. The specimens selected for testing shall be sound pipe having dimensions consistent with these specifications. The lot or lots from which the tests samples are taken shall be sufficient to fill the entire order for that size of pipe used in the work under the contract and, if they pass the tests, shall be so designated and marked.
 - 6. All pipe shall be subject to inspection at the factory, trench, or other point of delivery by the District. The purpose of the inspection shall be to cull and reject any pipe that, independent of the physical tests herein specified, fails to conform to the requirements of these specifications or that may have been damaged during transportation or in subsequent handling.
 - 7. If all of the minimum designated percentage or number of the specimens tested meet the requirements of the test, then all of the pipe in the lot, shipment, or delivery corresponding to the sizes and classes so tested shall be considered as complying with the test. If, however, 10-percent or more of the specimens tested fail to meet the requirements of the test or if more than one specimen fails to meet the requirements of the test when the number to be tested is less than ten, then a second selection of pipe shall be made for that test. The number of specimens to be tested in the second selection of pipe shall be five for each specimen of the first selection that failed to meet the requirements.

8. If 90-percent or more of the specimens tested, including those first tested, meet the requirements of the test, all the pipe in the lot, shipment, or delivery corresponding to the sizes and classes so tested shall be considered as complying with that test, otherwise all pipe of these sizes and classes shall be rejected.
 9. Causes for Rejection: The following imperfections in a pipe or special fitting shall be considered injurious and cause for rejection without consideration of the test results specified above.
 - a. A single crack in the barrel of the pipe
 - b. Surface imperfections, such as lumps, blisters, pits or flakes, on the interior surface of a pipe or fitting
 - c. When the bore or socket of the pipe varies from a true circle more than 3-percent of its nominal diameter
 - d. If the pipe or fitting is designated to be straight and it deviates from a straight line more than 1/16-inch per lineal foot. The deviation shall be measured from a straight edge at a point midway between the ends of the pipe.
 - e. A joint of pipe with a piece broken from either the socket or spigot end
 - f. Pipe joints that have tramp clays, grog or other foreign matter flushed permanently to the exterior or interior surface of the pipe or fittings
- D. Joints: All VCP fittings shall be furnished with compression joints.
1. The compression joint on the spigot and bell ends of the pipe shall be factory made of plastisol, polyurethane elastomer, or other approved resilient element bonded onto the outside of the spigot and the inside of the bell to the pipe and molded and cured to a uniform hardness and compressibility to form a tight compression coupling when assembled. Materials for compression joints shall conform to ASTM C425.
 2. Where pipe from different manufacturers is to be jointed together, an adapter pipe with the proper matching joint on each end for the respective manufacturer or an adapter with bushing or sleeves and stainless steel bands, matching each pipe end shall be used. Hot poured joints or concrete encasement of plain end joints shall not be permitted.
- E. Branches: Branches of the type shown on the plans shall be furnished with connections of the sizes specified and shall be securely and completely fastened to the barrel of the pipe in the process of manufacture. Tee branches shall have their axis perpendicular to the longitudinal axis of the pipe. Wye branches shall have their axis approximately 45 degrees (unless otherwise specified on the plans) to the longitudinal axis of the pipe, measured from the socket end. All branches shall terminate in sockets and the barrel of the branch shall be of sufficient length to permit making a proper joint.
- F. Stoppers: The stoppers for all pipe 8-inches in diameter and smaller, in which a sealing component for a flexible compression-type joint is cast, shall be neoprene, polyethylene, or polyurethane. Stoppers in all other cases shall be discs of the same material as the pipe, equal in diameter to the outside of the pipe barrel, and made and installed as accepted by the District.

1. Neoprene stoppers shall be manufactured from a compound containing not less than 50 percent neoprene by volume, which shall be the sole elastomer. Stoppers shall not be adversely affected when exposed to the chemical and bacteriological environments normally found in wastewater.
2. When installed and braced in place in branch spurs, stoppers shall withstand a hydrostatic pressure test of 10 psi with no leakage. When unbraced, stoppers shall remain in place when subjected to a maximum air pressure test of 5 psi.

2.02 POLYVINYL CHLORIDE (PVC) PIPE

A. Pipe and Fittings

1. **ASTM Requirements:** Pipe, fittings, couplings, and joints shall be in conformance with the size, material and performance requirements of ASTM D3034, SDR 35, and shall have gasketed joints. Pipe shall be made of PVC plastic having a cell classification of 12364 or 12454 as defined in ASTM D1784. Fittings shall be made of PVC plastic having a cell classification of 12454. All pipe shall be of solid wall construction with smooth interior and exterior surfaces.
2. **Manufacturer's Testing Certification:** During production of the pipe, the manufacturer shall perform the specified tests for each pipe marking. A certification by the manufacturer indicating compliance with specification requirements shall be delivered with the pipe. The certification shall include the test result data.
3. **Pipe Marking:** All pipe, fittings, and couplings shall be clearly marked at an interval not to exceed 5-feet as follows:
 - a. Nominal pipe diameter
 - b. PVC cell classification
 - c. Company, plant, shift, ASTM, SDR, and date designation
 - d. Service designation or legend

For fittings and couplings, the SDR designation is not required. All pipe shall have a home mark on the spigot end to indicate proper penetration when the joint is made.

4. **Additional Pipe Tests Following Delivery:** When pipe is delivered to the jobsite, the District may require additional testing to determine conformance with the requirements of pipe flattening, impact resistance, pipe stiffness, and extrusion quality. When testing is required, one test pipe shall be selected at random by the District from each 1,200 feet or fraction thereof of each size of pipe delivered to the jobsite but not less than one test pipe per lot. A lot shall be defined as pipe having the same identification marking. The length of specimen for each selected pipe shall be a minimum of 8-feet.
5. **Pipe Retest:** Pipe which is not installed within 120 days of the latest test shall not be used without prior acceptance by the District.
6. **Fitting and Coupling End Configurations:** The socket and spigot configurations for fittings and couplings shall be compatible with those used for the pipe.

B. Gaskets for PVC Pipe

1. General: Unless otherwise specified, gaskets shall be manufactured from a synthetic elastomer, and shall be extruded or molded and cured in such a manner as to be dense, homogeneous and of smooth surface, free of pitting, blisters, porosity, and other imperfections. The compound shall contain not less than 50 percent by volume of first-grade synthetic rubber. The remainder of the compound shall consist of pulverized fillers free of rubber substitutes, reclaimed rubber, and deleterious substances. The tolerance for any diameter measured at any cross section shall be $\leq 1/32$ -inch (.8mm).
2. Gasket Material Requirements: When required by the District, the Contractor shall furnish test samples of gaskets from each batch used in the work. Gasket material shall meet the following requirements:

Property	Value	ASTM Test Method
Tensile Strength (min. psi)	2,000	D412
Elongation at break (% min.)	350	D412
Shore durometer, Type A (Pipe manufacturer shall select value suitable for type of joint)	40 to 65*	D2240
Compression set (constant deflection) max % of original deflection	16	D395
Compression strength after oven aging (96 hours, 158°F {70°C}) % of tensile strength before aging	80	D573
Increase in Shore durometer hardness after oven aging. Maximum increase over original Shore durometer	10	D2240
Physical requirements after exposure to ozone concentration (150 pphm. 70 hours, 140°F {40°C}), 20% strain)	No Cracks	D1149

*This applies only to the sealing component of the gasket.

PART 3 EXECUTION

3.01 PLACEMENT OF PIPE IN TRENCH

A. General:

1. The Contractor shall follow all manufacturer’s installation instructions. If conflicts exist between manufacturer’s installation instructions and this specification, the more stringent requirements shall be used.
2. All pipe shall be laid to the line and grade given to form a close concentric joint with the adjoining pipe and prevent sudden offsets of the flow line. Pipe shall be laid from the downstream structure to the upstream structure, without grade breaks, with the bell ends of the pipe upstream.

- B. Trench Excavation: Dewatering, excavation, shoring, sheeting, bracing, backfill material placement, material compaction, compaction testing, and pipe laying requirements and limitations shall be in accordance with Section 02223.
- C. Subgrade at Joints: At each joint in the pipe, the pipe subgrade shall be recessed in firm bedding material so as to relieve the bell of the pipe of all load and to ensure continuous bearing along the pipe barrel.
- D. Cleaning: The interior of the sewer pipe shall be cleaned of all dirt and superfluous materials as the work progresses.
- E. Joints: The mating surfaces of the pipe to be joined shall be wiped clean of all dirt and foreign matter and a lubricant applied that is approved by the pipe manufacturer. Then, with the surfaces properly lubricated, the spigot end of the pipe shall be positioned inside the bell and the joint shoved home.
- F. For larger diameter pipe where a lever attachment is required, the necessary precautions shall be taken to insure an undamaged pipe installation.
- G. Pipe Alignment: Unless specified otherwise, pipeline line and grade shall be as shown on the plans. Grade shall be measured along the pipe invert.
- H. PVC Pipe Curvature:
 - 1. Construction of curved reaches of PVC pipe shall not be accomplished by deflecting joints or by beveling pipe ends.
 - 2. Longitudinal bending of pipe barrel:
 - a. Limit bend radius to no less than 200-percent of manufacturer's published allowable amount.
 - 1) Ensure a constant bend radius is achieved throughout the length of each pipe section and ensure there are no points of a shorter bend radius (i.e. tighter curvature).
 - b. Do not deflect joints when also longitudinally bending the pipe barrel.
 - 1) Implement construction measures to prevent any deflection of the joints when longitudinally bending the pipe barrel.
- I. Short Lengths of VCP Pipe: When using VCP, two 1-foot lengths of sewer pipe shall be used to provide curve flexibility and prevent cracking or shearing failures as shown on the plans or as may be required by the District during construction. The use of short lengths of pipe is particularly required, but not necessarily limited to these locations: (1) inlets and outlets to all manholes; (2) ends of steel casing pipe; (3) ends of concrete encasement; (4) vertical and horizontal curvilinear sewers; and (5) deep lateral connections.
- J. Backfill: Backfill shall be placed and compacted in accordance with the requirements of Section 02223. Backfill within the pipe zone shall be 3/4-inch crushed rock for PVC pipe and VCP. Wrap rock with filter fabric.

3.02 CLEANING

- A. Before testing, each pipe shall be thoroughly cleaned from manhole to manhole with a sewer scrubbing ball, and all debris and trash shall be removed from each manhole.

3.03 TESTING

- A. The pipe, manholes, and other appurtenances shall be tested for leakage and infiltration per Section 15043.

3.04 CLOSED-CIRCUIT TELEVISION INSPECTION

- A. General: In addition to the regular leakage and infiltration test, the entire length of all new sewer lines shall be inspected using closed-circuit television equipment. The inspection shall be conducted after the line has been successfully tested and prior to paving. The inspection shall be conducted in the presence of the District.
- B. Responsibility: All labor and equipment necessary to conduct this inspection shall be furnished by the Contractor.
- C. Notification: Requests for sewer line inspection shall be made to the District a minimum of five working days in advance of the requested inspection date.
- D. Flushing: Each sewer section shall be flushed with water being introduced at the upstream manhole of each section prior to video recording.
- E. Stationing: The video shall show stationing corresponding to sewer stationing shown on plans for each manhole and wye location.
- F. Sag Gauge: All closed-circuit television equipment shall be installed with a sag gauge visible in the video to determine sag depths.
- G. Submittal: The video shall be MPEG format compatible with the District's current viewer software and shall be submitted to the District with reports showing manhole numbers and stationing, wye stationing, and distance between manholes prior to Final Acceptance of the project by the District. The electronic file and reports shall be labeled with the project name, tract number, street names, and the Contractor's name and shall list the station of any defects, dirt, sags, etc. in the pipe. Reports and videos shall include defect coding in accordance with the National Association of Sewer Service Companies (NASSCO) Pipeline Assessment Certification Program (PACP).
- H. Repair of Defects: Even though the sewer line may have successfully passed the leakage and infiltration tests, any defects or sags in the line shall be repaired to the satisfaction of the District.
- I. Acceptance: Any sewer section having sags or defects shall be repaired by the Contractor prior to Final Acceptance of the project by the District. Sags in the line will not be allowed.

3.05 FINAL INSPECTION

- A. After paving has been completed and all manholes raised to grade, a final visual inspection shall be made. The necessary labor shall be furnished to assist the District in making the final inspection. Additional cleaning may be required if the lines are dirty, even though lines were previously cleaned. The Contractor shall furnish a responsible person or supervisor for the final inspection to remove manhole covers and to note any corrections required by the District in order to obtain final acceptance. Final District inspection shall be requested through the District by giving at least five days of notice.

END OF SECTION

SECTION 15068
SEWER LATERALS

PART 1 GENERAL

1.01 SECTION INCLUDES

- A. Vitrified clay pipe (VCP) sewer laterals
- B. Polyvinyl chloride (PVC) pipe sewer laterals
- C. Flexible saddles

1.02 RELATED REQUIREMENTS

- A. Section 02223, Trenching, Backfilling, and Compacting
- B. Section 15043, Testing of Non-Pressure Sewer Pipelines and Manholes
- C. Section 15066, Gravity Sewer Pipelines

1.03 REFERENCE STANDARDS

- A. ASTM International
 - 1. ASTM D5926: Standard Specification for Poly (Vinyl Chloride) (PVC) Gaskets for Drain, Waste, and Vent (DWV), Sewer, Sanitary, and Storm Plumbing Systems

1.04 SUBMITTALS

- A. Shop drawings shall be submitted in accordance with the General Provisions and as specified herein.
- B. An installation schedule (tabulated layout) shall be submitted which includes:
 - 1. Order of installation and closures
 - 2. Pipe centerline station and elevation at each change of grade and alignment
- C. Lateral elevation certification

PART 2 PRODUCTS

2.01 PIPE AND FITTINGS

- A. Refer to Section 15066 for product requirements.

2.02 SADDLES

- A. Banded flexible saddle wye
 - 1. Conform to ASTM D5926
 - 2. High durometer PVC
 - 3. Groove bands for straps
 - 4. Root-proof and leak-proof
- B. Straps and hardware shall be 316 Stainless Steel.

PART 3 EXECUTION

3.01 INSTALLATION

- A. Installation of pipe, fittings, and saddles shall be in accordance with manufacturer's recommendations and these specifications.

3.02 LATERALS

- A. General: VCP and PVC wyes, and other types of branches shall be furnished and installed along with the VCP or PVC sewer. Wyes sized as specified on the plans shall be installed for all sewer house connections and for future sewer house connections as shown on the plans. The longitudinal barrel of branch fittings, to be placed in line and grade with the sewer mains, shall be of the same diameter, quality, and type as specified herein for sewer installations. Earthwork and bedding for branches shall conform to the applicable provisions set forth in the specification for each pipe material. Unless otherwise specified, the branch of wye fittings shall be inclined upward at an angle not greater than 45 degrees from a horizontal line. The Contractor shall place a support of graded crushed rock under every wye branch when installed.
- B. Sequencing: Laterals shall be installed after mass grading is finished and before other utilities are installed.
- C. Lateral Elevation Certification: Certify the elevation of the house lateral and connection point.
- D. Locations: House laterals and wye branch fittings of the size indicated on the plans shall be installed at the locations shown on the plans or at the location furnished by the District.
- E. Plugged Branches: All branch fittings that are to be left unconnected shall be plugged or capped.
- F. Fittings: House laterals shall be joined to wye branch fittings at the sewer main as set forth above by eighth bends. All eighth bends and sixteenth bends are considered part of house lateral sewer line.
- G. Alignment: Where possible, all house laterals shall run perpendicular to the sewer main from the main to the property line, and all house laterals shall be bedded the same as the sewer main into which they connect.

MOULTON NIGUEL WATER DISTRICT

- H. Plugged House Laterals: All house laterals shall be plugged with an approved stopper in the socket of the last joint of each house lateral so that it will withstand the internal pressure during the test for leakage, but also in such a manner that it may be removed without injury to the socket.
- I. Marking: The Contractor shall mark the location of each sewer lateral at its upper end by chiseling a letter "S" 2-inches high on the face of the curb.
- J. Chimney Connections: Chimney connections are not allowed.
- K. Mainline Testing: The mainline sewer shall have passed final testing per Section 15043 before the laterals may be connected to the main.
- L. Inspection: The District shall be notified at least five days in advance of and be present to inspect all connections to the public sewer mains.

3.03 SADDLE CONNECTIONS

- A. Scoring and Tapping: The sewer line to be saddled shall be scored to the approximate shape of the wye and shall be cut with a hole cutter. The tap holes shall be cleanly machined and may be further worked by hand to provide a true and neat opening for the saddle wye. Pipe damaged during this operation shall be repaired or replaced, using a method that is acceptable to the District.
- B. Installation: Install banded flexible saddle wye per manufacturer's instructions.
- C. Encasement: After installation of the saddle, the District will inspect the connection and, if satisfactory, the Contractor shall encase the saddle with 3/4-inch crushed rock. Vibrate crushed rock to compact.
- D. Cleaning: The saddling operation shall be carried out in a workmanlike manner. Chips, dirt, concrete, and other debris shall be kept out of the sewer line being saddled. If directed by the District, the reach of sewer main saddled shall be flushed and cleaned using a hydrocleaner or vacuum truck.
- E. Cut-in Wye: Where lateral connection is size-on-size, a wye connection shall be made by installing a cut-in wye.

END OF SECTION

SECTION 15072

DISPOSAL OF ASBESTOS CEMENT PIPE

PART 1 GENERAL

1.01 SECTION INCLUDES

- A. Connection to and disposal of existing asbestos cement distribution pipe (ACP)

1.02 RELATED REQUIREMENTS

- A. Section 15064, PVC Pressure Distribution Pipe
- B. Section 15162, Pipe Couplings and Adapters

1.03 REFERENCED STANDARDS

- A. California Code of Regulations (CCR), Title 8, Section 1529, Asbestos
- B. ASTM D4397: Standard Specification for Polyethylene Sheeting for Construction, Industrial, and Agricultural Applications

1.04 SUBMITTAL

- A. Copies of the Contractor's certification from the Contractors State Licensing Board for asbestos removal shall be submitted to the District prior to the commencement of any asbestos removal activities.
- B. The Contractor is to provide manifests/disposal records to the District.

1.05 QUALITY ASSURANCE

- A. Cutting, removal, handling, and disposal of ACP shall be performed by a Contractor registered by the California Division of Occupational Safety and Health (Cal/OSHA) and certified by the Contractors State Licensing Board for asbestos removal.
- B. The Contractor or subcontractor shall comply with all State and Federal laws regarding handling and removal of asbestos materials. The Contractor shall provide sufficient supervision and monitoring to assure said conformance.
- C. Workers handling ACP shall be trained in accordance with applicable State regulations.
- D. Comply with requirements of CCR Title 8, Section 1529.

1.06 HEALTH HAZARD

- A. The Contractor is warned that asbestos is a known human carcinogen and poses serious health risks. Asbestos fibers are easily inhaled and can result in chronic respiratory illness, cancer, and other severe health effects.

PART 2 PRODUCTS

2.01 CONTAINMENT

- A. 6 mil (150-micron) polyethylene sheeting or bags and appropriate tape, in accordance with ASTM D4397-16

2.02 TRANSITION COUPLINGS

- A. Refer to requirements of Section 15162.

PART 3 EXECUTION

3.01 CUTTING, REMOVAL, AND HANDLING

- A. Adequate care shall be taken to maintain the materials in a non-friable state.
- B. Pipe cutting will be permitted only when repairing or joining existing ACP, as determined by the District.
- C. All cutting of ACP shall be by snap-cut method.
- D. ACP shall be wrapped in 6 mil (150-micron) polyethylene sheeting or bags sealed with appropriate tape, and properly labeled and removed away from the construction area to prevent damage.

3.02 DISPOSAL

- A. Asbestos materials are considered hazardous materials regulated as a hazardous waste in California.
- B. The Contractor shall be responsible for the proper identification, removal and disposal of all asbestos materials.

3.03 CONNECTING TO EXISTING ACP

- A. Connect to existing ACP with a transition coupling.
- B. Provide minimum 3-foot length PVC pipe spool between the transition coupling and new valve, fitting, or piping.

END OF SECTION

SECTION 15089

AIR VALVES

PART 1 GENERAL

1.01 SECTION INCLUDES

- A. Combination air valves

1.02 RELATED REQUIREMENTS

- 1. Section 09900, Painting and Coating
- 2. Section 15042, Hydrostatic Testing of Pressure Pipelines

1.03 REFERENCED STANDARDS

- A. American Water Works Association (AWWA)
 - 1. AWWA C213: Standard for Fusion-Bonded Epoxy Coating for the Interior and Exterior of Steel Water Pipelines
 - 2. AWWA C512: Air-Release, Air/Vacuum, and Combination Air Valves for Water and Wastewater Service
- B. ASTM International
 - 1. ASTM A126: Standard Specification for Gray Iron Castings for Valves, Flanges, and Pipe Fittings
 - 2. ASTM A240: Standard Specification for Chromium and Chromium-Nickel Stainless Steel Plate, Sheet, and Strip for Pressure Vessels and for General Applications
 - 3. ASTM A276: Standard Specification for Stainless Steel Bars and Shapes
- C. NSF International
 - 1. NSF 61: Drinking Water Systems Components – Health Effects

1.04 SUBMITTALS

- A. Product data sheets
- B. Shop drawings
- C. NSF 61 conformance certification for lining (for potable water applications)

1.05 QUALITY ASSURANCE

- A. Conform to AWWA C512. Where discrepancies exist between current AWWA C512 and this specification, the more stringent requirements shall govern.

PART 2 PRODUCTS

2.01 COMBINATION AIR VALVES

- A. Description: Combination valve assemblies shall function to accomplish the following:
1. Slowly release pockets of air which accumulate at high points, or changes in line gradient.
 2. Exhaust large quantities of air from the pipeline when being filled.
 3. Admit large quantities of air into the pipeline when being drained to prevent air lock or vacuum collapse of the pipe.

B. Materials for air valves ≤ 2”:

Item	Material	Specification
Body and Cover	Reinforced Nylon	-
Float, Lever Poppet	Foamed Polypropylene	-
Screws	Stainless Steel	ANSI Type 316
Drain Plug	Reinforced Nylon	-
Discharge Outlet	Polypropylene	-

C. Materials for air valves >2”:

Item	Material	Specification
Body and Cover	Cast Iron, Ductile Iron, or 316 Stainless Steel	ASTM A126, Class B - -
Float, Lever Poppet	Stainless Steel or Foamed Polypropylene	ANSI Type 316 -
Seat	Rubber	Buna-N (Chlorine Resistant)
Drain Plug	Bronze	85-5-5-5 Alloy
Casing bolts/nuts	Stainless Steel	ANSI Type 316

D. Interior valve lining:

1. Fusion bonded epoxy lined per AWWA C213 for valves greater than 2”.
2. Conform to requirements of NSF 61 for potable water applications.

E. Connections: All valves 2-inch and smaller shall have threaded inlets. All valves 3-inch and larger shall have flanged inlets.

F. Style:

1. 4-inch diameter and smaller valves: Both air-vacuum and air-release functions shall be contained in one valve body.

2. 6-inch diameter and larger valves: Separate valves for each function piped together to function as one unit is permitted. An isolation valve shall be installed between the two units.

2.02 AIR VALVE ENCLOSURES

A. Description:

1. Low density polyethylene construction within UV inhibitors
2. 1/2-inch vent holes at approximately 4-inch on center around circumference of enclosure

B. Color:

1. Sandstone, or approved equal
2. When used on recycled water, paint vent hole strip purple per Section 09900.

C. Enclosure size:

1. 2-inch and smaller air valves: 20-inch diameter by 36 inch high enclosure
2. 2-1/2-inch and larger air valves: 24-inch diameter by 36 inch high enclosure

PART 3 EXECUTION

3.01 INSTALLATION

- A. Install per manufacturer's recommendations.
- B. Clean threaded joints by wire brushing or swabbing. Apply Teflon joint compound or Teflon tape to pipe threads before installing threaded valves. Joints shall be watertight.

3.02 FIELD COATING

- A. Coat exterior of valve per requirements of Section 09900.

3.03 VALVE PRESSURE TESTING

- A. Test valves at the same time that the connecting pipelines are pressure tested. Refer to Section 15042.
- B. Protect or isolate any parts whose pressure rating is less than the test pressure.

END OF SECTION

SECTION 15100
MANUAL VALVES

PART 1 GENERAL

1.01 SECTION INCLUDES

- A. Bronze Ball Valves
- B. Metal Seated Gate Valves
- C. Tapping Vales
- D. Butterfly Valves
- E. Resilient-Seated Gate Valves
- F. Valve operators and appurtenances

1.02 RELATED REQUIREMENTS

- A. Section 02223, Trenching, Backfilling, and Compacting
- B. Section 09900, Painting and Coating
- C. Section 15042, Hydrostatic Testing of Pressure Pipelines
- D. Section 15056, Ductile-Iron Pipe and Fittings

1.03 REFERENCED STANDARDS

- A. American Water Works Association
 - 1. AWWA C105: Polyethylene Encasement for Ductile-Iron Pipe Systems
 - 2. AWWA C210: Liquid-Epoxy Coating Systems for the Interior and Exterior of Steel Water Pipelines
 - 3. AWWA C213: Fusion-Bonded Epoxy Coating for the Interior and Exterior of Steel Water Pipelines
 - 4. AWWA C500: Metal-Seated Gate Valves for Water Supply Service
 - 5. AWWA C504: Rubber-Seated Butterfly Valves
 - 6. AWWA C509: Resilient-Seated Gate Valves for Water Supply Service
 - 7. AWWA C510: Double Check Valve Backflow Prevention Assembly
 - 8. AWWA C515: Reduced-Wall, Resilient-Seated Gate Valves for Water Supply Service

B. ASTM International

1. ASTM A126: Standard Specification for Gray Iron Castings for Valves, Flanges, and Pipe Fittings
2. ASTM A536: Standard Specification for Ductile Iron Castings
3. ASTM B62: Standard Specification Composition Brass or Ounce Metal Castings

1.04 SUBMITTALS

- A. Product data sheets
- B. Materials
- C. Pressure rating
- D. Shop Drawings

1.05 QUALITY ASSURANCE

- A. The Contractor shall use valves from a single approved manufacturer for all valves throughout the project or development.

PART 2 PRODUCTS

2.01 GENERAL

- A. Valves shall be installed complete with operating handwheels or levers, extension stems, worm gear operators, operating nuts, and wrenches required for operation.
- B. Valves shall have the name of the manufacturer and the size of the valve cast or molded onto the valve body or bonnet or shown on a permanently attached plate.
- C. Valve body and trim casting shall be of domestic origin.

2.02 BRONZE BALL VALVES

- A. Aboveground Ball Valves 3 Inches and Smaller
 1. Aboveground threaded end ball valves, 1/4-inch through 3-inches, for water service shall be full bore port ball type having a minimum working pressure of 200 psi WOG. Valves shall have plastic coated lever operators.

2. Materials of construction shall be as described below:

<u>Component</u>	<u>Material</u>	<u>Specification</u>
Body	Bronze	ASTM B62
Ball	Bronze	ASTM B62
Seat, Seals	PTFE	
Stem	Bronze or Copper silicon	ASTM B62, B99 (Alloy 651), B584 B371 (Alloy 694)

3. Stem material shall have a minimum tensile strength of 60,000 psi and a minimum yield strength of 30,000 psi.

2.03 METAL SEATED GATE VALVES

- A. Valves shall conform to AWWA C500 and the following.
- B. Gate valves shall be designed for a working pressure of 150 psi or 250 psi as required.
- C. Valves shall be ductile iron bodied, solid bronze internal working parts, parallel faced, bottom wedging double-discs, non-rising stem opening to the left, O-Ring seals, and a 2-inch-square operating nut.
- D. Materials of construction shall be as described below:

<u>Component</u>	<u>Material</u>	<u>Specification</u>
Body, Bonnet	Cast Iron or Ductile Iron	--
Operating Nut, Stuffing Box	Bronze	ASTM B62
Bonnet Bolts	Stainless Steel	Type 316
Stuffing Box Bolts	Stainless Steel	Type 316
Interior Parts, Gate	Ductile Iron	ASTM A536
O-Rings	Synthetic rubber	ASTM D2000

- E. Gate valve stems shall be of low zinc content (2-percent), having a minimum tensile strength of 70,000 psi, a yield strength of 40,000 psi, and 12-percent elongation in 2-inches. The stem is to be visibly marked so that it meets this requirement.
- F. Gate valves shall be furnished with ends as specified on plans or by the District.

2.04 TAPPING VALVES

- A. Tapping valves shall conform to all requirements for gate valves 3 inches and larger and the additional requirements listed herein.
- B. All valve ends shall be flanged. The flange on one end shall have slotted bolt holes to fit all standard tapping machines.
- C. Seat rings shall be oversized to permit the use of full-size cutters.
- D. Resilient wedge valves may be used as tapping valves, provided that the disk fully retracts to produce a full port opening.

2.05 BUTTERFLY VALVES

- A. Butterfly valves shall be short body, conforming to AWWA C504, Class 150. Minimum working differential pressure across the valve disc shall be 150 psi unless specified otherwise on the plans.
- B. Butterfly valves shall be furnished and installed with the type of ends as shown on the plans and as herein specified. Flanged ends shall be Class 125, ANSI B16.1.
- C. Wafer style valves will not be permitted.
- D. Each valve body shall be tested under a test pressure equal to twice its design water working pressure.
- E. Valves shall be bubble tight at rated pressures and shall be satisfactory for throttling service and frequent operation after long periods of inactivity. Valve discs shall rotate 90 degrees from the full-open position to the tight-shut position.
- F. Valve shafts shall be Type 316 stainless steel. Valve shafts shall be dual stub shafts or a one-piece shaft extending completely through the valve disc.
- G. Materials of construction shall be as described below:

<u>Component</u>	<u>Material</u>	<u>Specification</u>
Body	Cast Iron or Ductile Iron	
Exposed Body Capscrews, and Bolts and Nuts	Stainless Steel	Type 316
Discs	Cast Iron Ductile Iron, or Ni-Resist	

- H. The rubber seat shall be an integral part of the valve body. Rubber seats fastened to the disc by any means shall not be permitted.

2.06 RESILIENT-SEATED WEDGE GATE VALVES

- A. Valves shall conform to AWWA C509 or AWWA C515 and the requirements listed herein.
- B. All valves shall be bubble tight at 200 psi working pressure.
- C. Valves shall have non-rising low zinc stems, opening by turning left and provided with a 2-inch-square operating nut. Outside stem and yolk valves shall be used on backflow device shutoff valves.
- D. Each valve shall have a smooth unobstructed waterway free from any sediment pockets.
- E. Stuffing boxes shall be O-ring seal type with two rings located in stem.
- F. Low friction torque reduction thrust bearings shall be located both above and below the stem collar.
- G. Materials shall be as described below:

<u>Component</u>	<u>Material</u>	<u>Specification</u>
Body, Operating Nut Bonnet, Seal Plate	Cast Iron or Ductile Iron	ASTM A126 Class B
Gate	Cast Iron or Ductile Iron	
Bonnet and Seal Bolts	Stainless Steel	Type 316
O-Rings	Synthetic Rubber	ASTM D2000

- H. All internal working parts (excluding gate) shall be all bronze containing not more than 2-percent aluminum or more than 7-percent zinc. Valve stems shall be cast or forged from bronze having a tensile strength of not less than 60,000 psi, a yield point of not less than 30,000 psi, and an elongation of not less than 10-percent in 2-inches.
- I. All gates shall be EPDM encapsulated.

2.07 BOLTS AND NUTS FOR FLANGED VALVES

- A. Bolts and nuts for flanged valves shall be Type 316 stainless steel in accordance with Section 15056.

2.08 GASKETS

- A. Gaskets for flanged end valves shall be as described in Section 15056.

2.09 VALVE OPERATORS

- A. Provide lever or wrench operators having adjustable, "position indicator" for exposed valves smaller than 6 inches.
- B. Provide 2-inch AWWA operating nuts for buried and submerged valves.
- C. Provide gear operators on butterfly valves 6-inches and larger. Gear operators for valves 8-inches through 20-inches shall be of the worm and gear, or of the traveling nut type. Gear operations for valves 24-inches and larger shall be of the worm and gear type.
- D. Gear operators shall be enclosed, suitable for running in oil with seals provided on shafts to prevent entry of dirt and water into the operator. Gear operators for valves located above ground or in vaults and structures shall have handwheels. Minimum handwheel diameter shall be 12 inches. The operator shall contain a dial indicating the position of the valve disc or plug. Gear operators for buried or submerged valves shall have 2-inch square AWWA operating nuts.
- E. For buried or submerged service, provide watertight shaft seals and watertight valve and actuator cover gaskets.
- F. Provide totally enclosed operators designed for buried or submerged service.
- G. Traveling nut and worm and gear operators shall be of the totally enclosed design so proportioned as to permit operation of the valve under full operating head with a maximum pull of 80 pounds on the handwheel or crank. Provide stop limiting devices in the operators in the open and closed positions. Operators shall be of the self-locking type to prevent the disc or plug from creeping. Design operator components between the input and the stop-limiting devices to withstand without damage a pull of 200 pounds for handwheel or chainwheel operators and an input torque of 300 foot-pounds for operating nuts when operating against the stops.
- H. Operators on buried valves shall produce the required torque on the operating nut with a maximum input of 150 foot-pounds.
- I. Valve operators, handwheels, or levers shall open by turning counterclockwise.

2.10 VALVE BOXES FOR BURIED VALVES

- A. Valve extension pipe material shall be 8-inch SDR 35 PVC pipe.
- B. Design cast iron valve box cover to rest within a frame on a cast-in-place concrete ring surrounding the valve extension pipe; size the tapered skirt of the cover for a close fit inside the upper sleeve portion of the valve box. Valve box covers for the potable water system shall be circular with the word "WATER" cast on the cover. Valve box covers for the recycled water system shall be circular with the word "RECYCLED" cast on the cover.

2.11 EXTENSION STEMS FOR BURIED VALVE OPERATORS

- A. Where the depth of the valve nut exceeds 96-inches, provide operating extension stems to bring the operating nut to a point 24-inches to 30-inches below the surface of the ground and/or box cover.

- B. Extension stems shall be steel and shall be complete with 2-inch-square operating nut.
- C. Valve stem extensions shall be of a solid design (no pinned couplings permitted) with guides.

2.12 FACTORY FINISHES

- A. Coat all ferrous surfaces.
 - 1. Interior and buried exterior surfaces:
 - a. Fusion bonded epoxy meeting requirements of AWWA C213
 - b. Liquid-epoxy meeting requirements of AWWA C210 allowed for touch up and when valve design uses bonded rubber seats
 - c. Conform to requirements of NSF 61 for interior coatings.
 - 2. Non-buried exterior surfaces: factory primer

PART 3 EXECUTION

3.01 JOINTS

- A. Bolt holes of flanged valves shall straddle the horizontal and vertical centerlines of the pipe run to which the valves are attached. Clean flanges by wire brushing before installing flanged valves. Clean flange bolts and nuts by wire brushing, lubricate threads with oil and graphite, and tighten nuts uniformly and progressively. If flanges leak under pressure testing, loosen or remove the nuts and bolts, reseal or replace the gasket, reinstall or retighten the bolts and nuts, and retest the joints. Joints shall be watertight.
- B. Clean threaded joints by wire brushing or swabbing. Apply Teflon joint compound or Teflon tape to pipe threads before installing threaded valves. Joints shall be watertight.
- C. Rubber ring grooves of valves shall be inspected before installation by the Contractor for ridges or holes that would interfere with the rubber ring. Interferences with the rubber ring shall be corrected to a satisfactory connection or the valves replaced, as required by the District. All valves shall have the same rubber-ring groove profile as the groove of the pipe couplings furnished with the pipe.

3.02 BUTTERFLY VALVE OPERATORS

- A. Butterfly valves shall be installed with the operators on the street centerline side of the pipeline.

3.03 EXTERIOR PROTECTION

- A. Valve Exterior Surface, Buried Service: Wrap buried valves with 8-mil polyethylene wrap per AWWA C105. Wrap beyond valve by 12 inches on both sides.
- B. Valve Exterior Surface, Above Grade or in Vault: Apply coatings per Section 09900. Coat all valve metal surfaces, except bronze and stainless steel surfaces.

- C. Stainless Steel Bolts and Nuts, buried service: Apply cosmoline grease corrosion guard per Section 15056 to all stainless steel bolts and nuts.

3.04 CONCRETE SUPPORTS

- A. Inline valves shall be anchored in concrete.
- B. Concrete supports will not be required under valves bolted to flanged fittings.
- C. Until supports are poured, valves shall be temporarily supported by placing wooden skids underneath the valve so that the pipe is not subjected to the weight of the valve.
- D. All concrete anchors and thrust blocks specified or required by the District are considered as part of the pipeline installation.

3.05 VALVE BOXES

- A. Valve boxes shall be firmly supported and shall be kept centered and plumb over the operating nut of the valve.
- B. Beveled sections of pipe will not be allowed at the top of the valve extension pipe. The top cut shall be square and machine made.
- C. During the construction of new tracts, the valve extension pipes for "key valves" identified by the District shall extend well above the ground level to permit ease of location in case of emergency shutoffs.
- D. The box cover shall be flush with the surface of the finished pavement or at any other level designated by the District.

3.06 BACKFILL

- A. All backfill within 24-inches of a valve shall be clean, washed sand.
- B. Backfill is to be placed and compacted in accordance with Section 02223.

3.07 VALVE LEAKAGE TESTING

- A. Test valves for leakage at the same time that the connecting pipelines are tested. See Section 15042 for pressure testing requirements.
- B. Valves shall have a pressure rating higher than or equal to the test pressure.
- C. All valves 16-inch and larger shall be hydrostatically shop tested to the valves working pressure in the presence of the District inspector. Each side of the valve shall be tested independently. Exterior epoxy shall be touched up as required. After testing, valves shall be palletized, shrink wrapped, and delivered to the job site.

3.08 VALVE LOCATION

- A. The location of all valves shall be marked with a 2-inch “V” chiseled in the curb face perpendicular to the valve. The offset distance, in feet, from the curb face to the valve shall be chiseled next to the “V”. Where a perpendicular offset is not possible, multiple tangential offsets will be required to allow triangulation of the valve location.

END OF SECTION

SECTION 15112

BACKFLOW PREVENTERS

PART 1 GENERAL

1.01 SECTION INCLUDES

- A. Backflow prevention assemblies

1.02 RELATED REQUIREMENTS

- A. Section 15056, Ductile-Iron Pipe and Fittings
- B. Section 15057, Copper, Brass and Bronze Pipe Fittings and Appurtenances
- C. Section 15100, Manual Valves
- D. Section 15150, Meters

1.03 REFERENCED STANDARDS

- A. Foundation for Cross-Connection Control and Hydraulic Research, University of Southern California, School of Engineering
 - 1. "Manual of Cross-Connection Control"
- B. American Water Works Association (AWWA)
 - 1. AWWA C510: Double Check Valve Backflow Prevention Assembly
 - 2. AWWA C511: Reduced-Pressure Principle Backflow Prevention Assembly

1.04 SUBMITTALS

- A. Product Data Sheet and Drawings
- B. Certification of approved device per the California State Water Resources Control Board
- C. Field testing certificate

PART 2 MATERIALS

2.01 BACKFLOW PREVENTION ASSEMBLY

- A. All backflow prevention assemblies shall conform to the latest edition of AWWA C510 or C511.
- B. Backflow prevention assemblies shall be on the latest approved list of backflow prevention devices from the U.S.C./F.C.C.C. & H.R. Institute and comply with the California State Water Resources Control Board.

2.02 SHUT-OFF VALVES

- A. The shut-off valves for assemblies 3-inch and larger shall be resilient seat gate valves. Ball valves shall be used on assemblies smaller than 3-inch. Shut-off valves shall conform to Section 15100.
- B. Shut-off valves shall have outside stems and yokes.

2.03 BYPASS PIPING

- A. Bypass piping shall be copper or brass conforming to Section 15057.

2.04 FIRE SERVICE BYPASS METER

- A. The bypass meter shall conform to the requirements of Section 15150 and shall be compatible with the backflow device on which it is installed. The backflow prevention assembly and the bypass meter shall be furnished as one complete unit. All bypass meters shall be 3/4-inch, with registers reading in cubic feet.

PART 3 EXECUTION

3.01 INSTALLATION

- A. Installation shall comply with the requirements of the latest edition of the Manual of Cross-Connection Control.

3.02 TESTING

- A. Upon completion of the installation of the device, a test shall be performed and a certificate of the adequacy and operational compliance shall be furnished to the District. The tests shall be performed by a testing agency approved by the Orange County Health Department.

END OF SECTION

SECTION 15139
FIRE HYDRANTS

PART 1 GENERAL

1.01 SECTION INCLUDES

- A. Wet barrel fire hydrants

1.02 RELATED REQUIREMENTS

- A. Section 02223, Trenching, Backfilling, and Compacting
- B. Section 09900, Painting and Coating
- C. Section 15042, Hydrostatic Testing of Pressure Pipelines
- D. Section 15056, Ductile-Iron Pipe and Fittings

1.03 REFERENCED STANDARDS

- A. ASTM B62: Standard Specification for Composition Bronze or Ounce Metal Castings
- B. AWWA C503: Wet-Barrel Fire Hydrants
- C. AWWA M17: Fire Hydrants: Installation, Field Testing, and Maintenance

1.04 SUBMITTALS

- A. Product data sheets
- B. Shop drawings

PART 2 PRODUCTS

2.01 WET BARREL HYDRANT

- A. General: Conform to AWWA C503.
- B. Hydrant Top Section
 1. Fire hydrants shall have individual valves for each outlet opening counter clockwise. Fire hydrants for residential use shall have one 2-1/2 inch hose nozzle and one 4-inch pumper nozzle. Fire hydrants for commercial or industrial developments shall have one (1) 2-1/2 inch hose nozzle and two (2) 4-inch pumper nozzles.
 2. All outlets shall have National Standard Hose Threads.
 3. The hydrant top section shall be manufactured of bronze conforming to ASTM B62.

4. All interior working parts, including stems, shall be of bronze containing no more than 7-percent zinc or 2-percent aluminum.
5. Hydrants are to be provided with:
 - a. 1-1/2-inch sized pentagon-shaped operating nut, and
 - b. 1-1/2-inch capnuts
6. All fire hydrants shall have the name of the manufacturer cast onto the hydrant body or shown on a permanently attached plate.
7. Plastic outlet nozzle caps shall be provided for all outlets. Caps shall be securely chained to the barrel with non-kinking metal chain in a manner to permit free rotation of the cap.
8. All hydrant flanges shall be eight-hole regular, Class 125, American Standard cast iron flange drilling.

C. Bury Section

1. The bury section shall be 6-inch (cast-iron or ductile-iron) long radius bury elbow and shall be cement lined in conformance with Section 15056. Bury inlet shall be 6-inch rubber-ring hub bell connection for C900 PVC pressure pipe.
2. A flanged ductile iron spool shall be installed to position the hydrant flange 4 inches above the concrete pad (finish grade).
3. All wet-barrel fire hydrant cast-iron and ductile-iron buries are to be cement lined.
4. When using a riser spool, bolts shall be Type 316 stainless steel, standard non break-away.
5. Bury section outlet and riser spool flanges shall be eight-hole regular, Class 125, American Standard cast-iron flange drilling.

D. Break-Off Check Valve

1. DI Body
2. 250 psi rating
3. Retrofit existing concrete pad as required to install on existing hydrant
4. Use 316 SS bolts for break-off valve application

2.02 BREAK-AWAY BOLTS

- A. Unless otherwise specified, break-away bolts shall not be used to join the spool section to the hydrant top section.
- B. All bolts, and nuts, shall be Type 316 stainless steel.

2.03 GASKETS

- A. Gaskets shall be of rubber composition per Section 15056.

PART 3 EXECUTION

3.01 GENERAL

- A. Fire hydrant assemblies shall be installed in accordance with the standard drawing and as specified herein, and shall include the connection to the main, the fire hydrant, hydrant bury, shutoff valve, valve well and valve box, connection piping, concrete thrust blocks, and appurtenances.
- B. Conform to AWWA M17.

3.02 TRENCHING, BACKFILLING, AND COMPACTING

- A. All trenching, backfilling, compaction, and other excavation shall be in accordance with Section 02223.
- B. All backfill within 24 inches of a valve shall be imported sand.

3.03 BREAK-AWAY BOLTS

- A. Break-away bolts shall be installed with the threads away from the top of the hydrant.

3.04 FIELD COATING

- A. All public fire hydrants shall be painted in accordance with Section 09900.

3.05 TESTING

- A. Test hydrants at the same time that the connecting pipeline is pressure tested. See Section 15042 for pressure testing requirements.

END OF SECTION

SECTION 15150

METERS

PART 1 GENERAL

1.01 SECTION INCLUDES

- A. Customer Meters and Fire Service Bypass Meters (3/4-inch through 1-inch)
- B. Customer Meter (1-1/2 inch through 2 inch)
- C. Commercial and Irrigation Customer Meters (3-inch through 8-inch) and Commercial Bypass Meters (2-inch)
- D. Propeller Flowmeters
- E. Magnetic Flowmeters

1.02 RELATED REQUIREMENTS

- A. Section 15042, Hydrostatic Testing of Pressure Pipelines

1.03 REFERENCED STANDARDS

- A. American Water Works Association
 - 1. AWWA C700: Cold-Water Meters -- Displacement Type, Metal Alloy Main Case
 - 2. AWWA C701: Cold-Water Meters -- Turbine Type, for Customer Service
 - 3. AWWA C702: Cold-Water Meters -- Compound Type
 - 4. AWWA C703: Cold-Water Meters -- Fire Service Type
 - 5. AWWA C704: Propeller-Type Meters for Waterworks Applications
 - 6. AWWA C710: Cold-Water Meters -- Displacement Type, Plastic Main Case
 - 7. AWWA C751: Magnetic Inductive Flowmeters
 - 8. AWWA M6: Water Meters--Selection, Installation, Testing and Maintenance
- B. ASTM International
 - 1. ASTM A193: Standard Specification for Alloy-Steel and Stainless Steel Bolting for High Temperature or High Pressure Service and Other Special Purpose Applications
 - 2. ASTM A194: Standard Specification for Carbon Steel, Alloy Steel, and Stainless Steel Nuts for Bolts for High Pressure or High Temperature Service, or Both

1.04 COORDINATION

- A. All residential meters 3/4-inch through 2-inch will be furnished by the District, subsequent to payment of all applicable charges, and installed by the Applicant.

MOULTON NIGUEL WATER DISTRICT

- B. All industrial, commercial, individual service meters 3-inch and larger will be supplied and installed by the Applicant and dedicated to the District subsequent to payment of applicable charges.
- C. Prepayment of meters and appurtenances is not allowed. Upon payment of fees for meter and appurtenances, the entire meter package must be collected at that time. The District will not store meters and appurtenances after payment of charges. The meter package consists of meter box, gaskets, tailpieces, shut-offs, meter, and all other appurtenant facilities. The Applicant will be charged for the specified minimum billing per billing period for all tailpieces and shut-offs, regardless of whether or not the meter was used.
- D. Subsequent applications for permanent service shall be made in accordance with the District's Rules and Regulations.

1.05 SUBMITTALS

- A. Product data sheets and drawings

PART 2 PRODUCTS

2.01 CUSTOMER METERS AND FIRE SERVICE BYPASS METERS (3/4-INCH THROUGH 1-INCH)

- A. Meter shall be electromagnetic type.
- B. Meter body and flow tube shall be constructed of composite alloys and contain no metal material. Coated silver electrodes embedded in the flowtube shall be used to measure flow velocity.
- C. The register shall be hermetically sealed with a nine digit programmable electronic register and LCD display. The meter shall be compatible with common AMR/AMI systems. The register shall be Sensus protocol and include a touch read device.
- D. 3/4-inch meters shall be rated at 200 psi maximum operating pressure and 1-inch meters shall be rated at 175 psi maximum operating pressure.
- E. The manufacturer shall furnish certified results for each meter showing that it has been tested for accuracy of registration and pressure loss requirements with respect to the accuracy and capacity requirements of AWWA C700 and AWWA C710 when tested in accordance with AWWA Manual M6.
- F. Meters shall be NSF/ANSI Standard 61 Annex F and G compliant.
- G. Meter shall be provided with threaded end connections.
- H. All registers shall be of integrated tamper-proof construction with magnetic tamper and low field alarms. Safety wiring of standard bolts and screws is NOT considered an acceptable method of tamper-proofing.
- I. The serial number of each meter shall be imprinted on the register.

- J. Meters shall be supplied with the following warranty, which shall not be prorated under any conditions:
 - 1. All meters shall be guaranteed to maintain new-meter accuracy (+/- 1.5-percent) for twenty years.
 - 2. All meters shall have a twenty year battery life guarantee.
- K. Meters shall be guaranteed to maintain a low flow accuracy of +/- 3-percent over the following ranges

Meter size (inches)	Low Flow Range with +/- 3-percent Accuracy	Starting Flow
3/4	>.11 gpm to <0.18 gpm	0.03 gpm
1	>.3 gpm to <0.4 gpm	0.11 gpm

2.02 CUSTOMER METER (1-1/2-INCH THROUGH 2-INCH)

- A. Meter housing shall be constructed of polyphenylene sulfide (PPS) mounted in a stainless steel body. Volume shall be measured using a bidirectional ultrasonic technique based on the transit time method. The meter shall have no moving parts.
- B. Meter shall be IP68 (submersible) type suitable for installation in meter pits.
- C. The register shall be hermetically sealed with a nine digit programmable electronic register and LCD display. The meter shall be compatible with common AMR/AMI systems. Consumption data may be read visually from the display, with an optical eye, and remotely, either with a built in 915 MHz band RF signal or by a three wire encoded interface. The register shall be Sensus protocol and include a touch read device.
- D. Meters shall be rated at 300 psi maximum operating pressure.
- E. The manufacturer shall furnish certified results for each meter showing that it has been tested for accuracy of registration and pressure loss requirements with respect to the accuracy and capacity requirements of AWWA C700 and AWWA C710 when tested in accordance with AWWA Manual M6.
- F. Meters shall be NSF/ANSI Standard 61 compliant.
- G. Meter shall be provided with flanged end connections.
- H. Meters shall be guaranteed to maintain a low flow accuracy of +/- 3-percent over the following ranges

Meter size (inches)	Leak Flow Detection	Extended Low Flow Range	Max. Flow for continuous operation
1-1/2	0.06 gpm	0.4 – 1.2 gpm	120 gpm
2	0.1 gpm	0.5 – 1.5 gpm	160 gpm

2.03 COMMERCIAL AND IRRIGATION CUSTOMER METERS (3-INCH THROUGH 8-INCH) AND COMMERCIAL BYPASS METERS (2-INCH)

- A. Provide turbine meters in conformance with AWWA C701 and AWWA C702 Class II and the requirements specified herein. Turbine meters used for fire service shall comply with AWWA C703.
- B. The manufacturer shall furnish certified test results for each meter showing that it has been tested for accuracy of registration and that it complies with accuracy and capacity requirements of AWWA C701 and AWWA C702 Class II when tested in accordance with AWWA Manual M6.
- C. Meters shall have ductile iron main cases with a fusion bonded epoxy NSF approved lining and coating. Main case for turbine meters 3” in size shall be 304 stainless steel. Meter assemblies shall be provided with ANSI Class 125 flat faced flanges conforming to ANSI B16.1. Turbine meters shall be rated for a maximum operating pressure of 200 psi.
- D. Meters shall be NSF/ANSI Standard 61 Annex F and G compliant.
- E. Measuring chamber assembly shall utilize “floating ball” impeller with a coated titanium shaft, hybrid thermoplastic radial bearings, and sapphire/ceramic thrust bearings.
- F. Fully electronic hermetically sealed register with electronic pickup containing no moving parts and programmable registration. The electronic register shall at a minimum include AMR resolution units fully programmable, large easy to read LED display, integral data logging capability, and pulsed output frequency fully programmable. The register shall be Sensus protocol and include a touch read device.
- G. Meters shall be equipped with strainers. All strainers shall be furnished with stainless steel screens with an effective open area at least double the area of the meter. On metered fire service installations, a U.L/FM. approved strainer is required.
- H. The serial number of each meter shall be imprinted on the register cover and the main case.

2.04 PROPELLER METERS

- A. All propeller meters shall conform to AWWA C704 and the requirements specified herein.
- B. The meter tubing shall be fabricated steel with straightening vanes and provided with fusion bonded epoxy NSF approved coating and lining. Tube shall be constructed with 150 lb. AWWA Class D flat face flanged ends.
- C. Meter head shall be mounted on a flanged connection for easy removal of all interior parts from the pipe tee without disturbing the connections to the pipeline.
- D. Bearing in propeller shall be a water lubricated ceramic sleeve and spindle bearing system with a ceramic/stainless steel spindle. Provide dual ceramic thrust bearings to handle flows in both forward and reverse directions.
- E. Bearings within the sealed meter mechanism shall be shielded precision stainless steel bearings, factory lubricated for the life of the meter.
- F. All meters shall be provided with injection molded thermoplastic propellers.
- G. Stainless steel gear boxes on the propeller drive shafts are required.

2.05 MAGNETIC FLOWMETER

- A. All magnetic flowmeters shall conform to AWWA C751 and the requirements specified herein.
- B. Mounting style shall be ASME B16.5 Class 150 or Class 300 flanges and shall be equivalent to adjacent flanges,
- C. Flowmeter will be designed for IP68 and NEMA 6P submersible construction.
- D. Case and flanges shall be mild steel coated with a polyurethane resin. Liner shall be NSF 61 certified. Electrodes shall be compatible with and recommended for use with NSF 61 liner.
- E. Converter shall be combined or separate dependent on District acceptance. Converter shall be equipped with a LED readout and, at a minimum, provide instantaneous flowrate and totalizer readings.

2.06 HARDWARE

- A. All bolts, nuts, cap screws, studs, and washers shall be Type 316 stainless steel ASTM A193 B8M for bolts, and ASTM A194 8M for nuts.

PART 3 EXECUTION

3.01 BYPASS VALVES

- A. Provide lockable valves (in the closed position) on all bypass lines. On 3-inch and larger bypass lines, resilient seat gate valves with hand wheels and a chain and lock are permitted.

3.02 TEST TAP

- A. On services 3 inches and larger, a 2-inch nipple with ball valve service saddle or welded coupling and corporation stop shall be installed on the spool downstream of the meter. The tap shall be located a minimum of three (3) pipe diameters downstream of the meter. On propeller meter installations, the location of the test tap will be determined by the District.

3.03 TESTING

- A. All meter services shall be hydrostatically pressure tested during the testing of pipeline in accordance with Section 15042.

END OF SECTION

SECTION 15151

**POTABLE WATER, RECYCLED WATER, AND WASTEWATER FACILITIES
IDENTIFICATION**

PART 1 GENERAL

1.01 SECTION INCLUDES

- A. Warning Tape
- B. Warning Labels
- C. Witness Markers
- D. Stenciling

1.02 RELATED REQUIREMENTS

- A. Section 09900, Painting and Coating
- B. Section 15100, Manual Valves
- C. Section 15139, Fire Hydrants

1.03 SUBMITTALS

- A. Product data sheets

PART 2 PRODUCTS

2.01 WARNING TAPE FOR BURIED PIPE

- A. The plastic warning tape shall be an inert plastic film specifically formulated for prolonged underground use.
- B. The minimum thickness shall be 4 mils.
- C. Overall width of the tape shall be 12 inches (for 8-inch and larger pipe) and 6 inches (for 6-inch and smaller pipe).
- D. Lettering:
 - 1. Potable Water: Blue background with the following words in black letters: "CAUTION: POTABLE WATER-LINE BURIED BELOW"
 - 2. Recycled Water: Purple background with the following words in black letters: "CAUTION: RECYCLED WATER-LINE BURIED BELOW"

3. Sewer: Green background with the following words in black letters: "CAUTION: SEWER-LINE BURIED BELOW"

2.02 WARNING LABELS FOR EXPOSED PIPE AND APPURTENANCES

- A. Labels shall be inert plastic film specifically formulated for prolonged exposure.
- B. The minimum thickness shall be 4 mils for adhesive backed labels and 10 mils for tag type labels.
- C. Tag type labels shall have reinforced tie holes and shall be attached with heavy-duty nylon fasteners.
- D. Provide with 1/2-inch high black letters (minimum):
 1. Potable Water: Blue background with the following words in black letters: "POTABLE WATER"
 2. Recycled Water: Purple background with the following words in black letters: "CAUTION: RECYCLED WATER – DO NOT DRINK"
- E. The size and type of label will be dictated by each individual application and subject to acceptance by the District.

2.03 WITNESS MARKERS

- A. Design:
 1. High visibility
 2. Equipped with a barb or other such device to secure marker in the surrounding soil
- B. Materials: UV-resistant fiberglass
- C. Identification:
 1. Potable Water: Blue background with the following words in black letters: "POTABLE WATER"
 2. Recycled Water: Purple background with the following words in black letters: "RECYCLED WATER"
 3. Sewer: Green background with the following words in black letters: "SEWER"

PART 3 EXECUTION

3.01 INSTALLATION OF PIPE WARNING TAPE

- A. Install warning tapes 12-inches above all pipe.
 1. Longitudinally center over pipe.
 2. Install warning tape continuously for the length of the pipe.

3.02 INSTALLATION OF WARNING LABELS

- A. Install warning labels on all appurtenances in vaults, such as, but not limited to, air release valves, blow offs, and meters, and on designated facilities, such as, but not limited to, controller panels, wash down or blow off hydrants, on water trucks, and temporary construction services.
- B. Location of labels will be dictated by each individual application and subject to acceptance by the District.
- C. Firmly attach warning labels to all appurtenances using heavy-duty nylon fasteners.
- D. Painted labels may, at the District discretion be acceptable in lieu of plastic labels.

3.03 INSTALLATION OF WITNESS MARKERS (UNPAVED AREAS)

- A. Install witness markers over all pipe in unpaved areas and open space areas at intervals not greater than 200 feet.
- B. Install witness markers at all appurtenances, including but not limited to valves, valve boxes, air release/vacuum breaks, dead ends, inflection points, and tees.
- C. Witness markers shall be embedded into the soil at least 18-inches or as directed by manufacturer; the more stringent requirement shall apply.

3.04 COLOR AND STENCILING OF POLYETHYLENE ENCASEMENT SLEEVES

- A. Ductile iron pipe carrying recycled water: Pantone 512C purple 8-mil polyethylene sleeve with the words "RECYCLED WATER" stenciled with 2-inch black letters.
- B. Service lines
 - 1. Potable water: Blue 8-mil polyethylene sleeve
 - 2. Recycled water: Pantone 512C purple 8-mil polyethylene sleeve.

3.05 STENCILING

- A. Stencil all pipe as follows:
 - 1. PVC or ductile iron pipe carrying potable water, and located in the vicinity of recycled water piping:
 - a. Stencil the words "POTABLE WATER" with 2-inch black letters.
 - b. Lettering shall be on both sides of the pipe in at least three places in a 18-foot section of pipe (total six places per section of pipe).
 - 2. PVC or ductile iron pipe carrying recycled water:
 - a. Stencil the words "CAUTION: RECYCLED WATER – DO NOT DRINK" in 5/8-inch letters.
 - b. Lettering shall appear on both sides of the pipe repeated every 12 inches.

3.06 COLOR OF BURIED PVC PIPE

- A. Potable water: Blue
- B. Recycled Water: Pantone 522C Purple
- C. Sewer: Green

3.07 VALVE AND METER BOXES

- A. All valve and meter boxes for recycled water facilities shall have covers with the inscription "RECYCLED" cast thereon.
- B. Valve box lids for recycled water shall be painted purple per requirements of Section 09900.
- C. Steel meter box lids for recycled water shall be painted purple per requirements of Section 09900.
- D. Polymer meter box lids shall be tinted purple.

3.08 RESTRICTION OF PUBLIC ACCESS

- A. All off-site recycled water facilities shall be restricted from public access so that the general public cannot draw water from the system. Facilities such as air release assemblies, blow-off hydrants, blow offs on strainers, and other such facilities, shall be restricted from public access.
- B. Recycled water facilities, both above and below grade, shall be housed in an approved lockable container colored purple. A sign reading "CAUTION: RECYCLED WATER" shall be installed, its size accepted by the District. Other means of restricting public access may be accepted by the District.

END OF SECTION

SECTION 15162

PIPE COUPLINGS AND ADAPTERS

PART 1 GENERAL

1.01 SECTION INCLUDES

- A. Sleeve-Type Couplings
- B. Restrained Sleeve-Type Couplings
- C. Restrained One-Piece Coupling

1.02 RELATED REQUIREMENTS

- A. Section 09900, Painting and Coating
- B. Section 15042, Hydrostatic Testing of Pressure Pipelines

1.03 DEFINITIONS

- A. Straight coupling: A coupling that uses end rings of the same size and a center sleeve with ends of proper inside diameters to join pipes of the same outside diameters
- B. Reducer coupling: A coupling that uses end rings of different sizes and a center sleeve with ends of proper inside diameters to join pipes of different outside diameters
- C. Transition coupling: A coupling used to join pipe of the same nominal size, but of differing outside diameters. Differences in pipe outside diameters are accommodated by specially sized gaskets and, when necessary, specially sized end rings.
- D. Flange coupling adapters: A coupling used to connect plain-end pipe to a flange. It consists of a flange, center sleeve, gasket, and an end ring connected with bolts and nuts.

1.04 REFERENCED STANDARDS

- A. American Water Works Association
 - 1. AWWA C105: Polyethylene Encasement for Ductile-Iron Pipe Systems
 - 2. AWWA C111: Rubber-Gasket Joints for Ductile-Iron Pressure Pipe and Fittings
 - 3. AWWA C213: Fusion-Bonded Epoxy Coating for the Interior and Exterior of Steel Water Pipelines
 - 4. AWWA C219: Bolted, Sleeve-Type Couplings for Plain-End Pipe
 - 5. AWWA M11: Steel Pipe: A Guide for Design and Installation

B. ASTM International

1. ASTM A36: Standard Specification for Carbon Structural Steel
2. ASTM A193: Standard Specification for Alloy-Steel and Stainless Steel Bolting for High Temperature or High Pressure Service and Other Special Purpose Applications
3. ASTM A194: Standard Specification for Carbon Steel, Alloy Steel, and Stainless Steel Nuts for Bolts for High Pressure or High Temperature Service, or Both
4. ASTM A283: Standard Specification for Low and Intermediate Tensile Strength Carbon Steel Plates
5. ASTM A285: Standard Specification for Pressure Vessel Plates, Carbon Steel, Low- and Intermediate-Tensile Strength
6. ASTM A536: Standard Specification for Ductile Iron Castings
7. ASTM A576: Standard Specification for Steel Bars, Carbon, Hot-Wrought, Special Quality

C. NSF International (NSF)

1. NSF 61: Drinking Water System Components – Health Effects

1.05 SUBMITTALS

A. Product data sheets

1. Materials
2. Pipe material and outside diameter dimensions suitable for coupling
3. Pressure rating

B. Shop drawings

PART 2 PRODUCTS

2.01 SLEEVE-TYPE COUPLINGS

A. Design:

1. Comply with AWWA C219
2. Assembly consisting of a center sleeve, gaskets, and end rings connected with bolts and nuts. Tightening of the fasteners transfers the load through the end rings and compresses the gaskets into the space between the inside of the center sleeve and the outside surface of the pipe ends.
3. Types: Straight couplings, reducing couplings, transition couplings, and flange coupling adapters

B. Pressure rating: Greater than or equal to the pressure rating of adjacent piping

C. Materials:

1. Center rings/sleeve: Ductile iron per ASTM A536, grade 65-45-12 or carbon steel per ASTM A283, grade C
2. End Rings/followers: Ductile iron per ASTM A536, grade 65-45-12 or carbon steel per ASTM A576, grade 1020
3. Gaskets: Styrene-butadiene (SBR)
4. Sleeve Bolts: Type 316 stainless steel per ASTM A-193 (Grade B8M)
5. Nuts: Type 316 stainless steel per ASTM A-194 (Grade B8M)

2.02 RESTRAINED SLEEVE-TYPE COUPLINGS

A. General:

1. Comply with AWWA C219
2. Sleeve-type coupling with restraining end rings/followers consisting of multiple gripping lugs/wedges/pads around the pipe circumference
 - a. Specifically designed for the pipe material being connected to coupling
 - b. Proper actuation of the gripping lugs/wedges/pads achieved through use of torque limiting twist off nuts
3. Types: Straight couplings, reducing couplings, transition couplings, and flange coupling adapters

B. Pressure rating: Greater than or equal to the pressure rating of adjacent piping

C. Materials:

1. Center rings/sleeve: Ductile iron per ASTM A536, grade 65-45-12 or carbon steel per ASTM A283, grade C
2. End Rings/followers: Ductile iron per ASTM A536, grade 65-45-12 or carbon steel per ASTM A576, grade 1020
3. Gaskets: Styrene-butadiene (SBR)
4. Sleeve Bolts: Type 316 stainless steel per ASTM A-193 (Grade B8M)
5. Nuts: Type 316 stainless steel per ASTM A-194 (Grade B8M)
6. Restraining lugs/wedges/pads: Heat treated ductile iron

2.03 RESTRAINED ONE-PIECE COUPLING

A. General:

1. One-piece coupling with one bolt and nut per end and no loose components. When tightened, coupling shall simultaneously seal and restrain pipe end using rotating end rings, draw hook fasteners, and individual grippers. Individual grippers compensate for angular deflection and distribute load evenly around pipe circumference.
 - a. Specifically designed for the pipe material being connected to coupling
2. Types: Straight couplings and flange coupling adapters

- B. Pressure rating: Greater than or equal to the pressure rating of adjacent piping
- C. Materials:
 - 1. Center rings, end rings, and bolt guides: Ductile iron per ASTM A536, grade 65-45-12
 - 2. Grippers: Ductile iron per ASTM A536, grade 65-45-12, machine sharpened, heat treated, Xylan 1424 coated
 - 3. Gaskets: Styrene-butadiene (SBR)
 - 4. Draw hook fasteners: Type 304L stainless steel
 - 5. Bolts and nuts: Type 316 stainless steel

2.04 FACTORY FINISHES

- A. Coat all interior and exterior ferrous surfaces as follows:
 - 1. Center rings/sleeves and all interior/wetted surfaces: Fusion bonded epoxy meeting requirements of AWWA C213 and NSF 61
 - 2. End rings/followers and other exterior surfaces: Fusion bonded polyester, 5 mil thickness

PART 3 EXECUTION

3.01 INSTALLATION OF FLEXIBLE PIPE COUPLINGS

- A. Clean oil, scale, rust, and dirt from pipe ends. Clean gaskets in flexible pipe couplings before installing.
- B. Install expansion joints per manufacturer's written recommendations.
- C. Install expansion joints so that 50-percent of total travel is available for expansion and 50-percent is available for contraction.
- D. Lubricate bolt threads with graphite and oil prior to installation.

3.02 FIELD COATING

- A. Wrap the couplings with 8-mil polyethylene wrap per AWWA C105. Wrap beyond coupling by 12 inches on both sides.
- B. Apply cosmoline grease corrosion guard, per Section 15056, to all hardware.
- C. Coat all non-buried pipe couplings per requirements of Section 09900. Apply prime coat at factory.

3.03 HYDROSTATIC TESTING

- A. Hydrostatically test flexible pipe couplings, expansion joints, and expansion compensators in place with the pipe being tested. Test in accordance within Section 15042.

END OF SECTION

SECTION 15170

WALL AND SLAB PENETRATIONS

PART 1 GENERAL

1.01 SECTION INCLUDES

- A. Wall Pipe Modular Seals
- B. Wall Pipes and Sleeves

1.02 REFERENCED STANDARDS

- A. American Iron and Steel Institute (AISI)
- B. American Water Works Association (AWWA):
 - 1. AWWA C115: Flanged Ductile-Iron Pipe with Ductile-Iron or Gray-Iron Threaded Flanges
 - 2. AWWA C210: Liquid-Epoxy Coating Systems for the Interior and Exterior of Steel Water Pipelines
 - 3. AWWA C116: Protective Fusion-Bonded Epoxy Coatings for the Interior and Exterior Surfaces of Ductile-Iron and Gray-Iron Fittings

1.03 SUBMITTALS

- A. Submit the following for each type of product specified:
 - 1. Product data including dimensions, materials, and pressure ratings
 - 2. Shop Drawings
 - 3. Certifications

PART 2 PRODUCTS

2.01 WALL PIPE MODULAR SEALS

- A. Description
 - 1. Inter-locking synthetic rubber links shaped to continuously fill the annular space between the pipe and the wall opening
 - 2. Sized and selected per the manufacturer's recommendations
- B. Performance Criteria
 - 1. Seal pressure rating: 20 psig

- C. Materials
 - 1. Links: Nitrile rubber
 - 2. Hardware: AISI Type 316 Stainless Steel
 - 3. Pressure Plates: Reinforced nylon polymer

2.02 WALL PIPES AND SLEEVES

- A. Description
 - 1. General:
 - a. Pipes or sleeves cast into concrete wall
 - b. Provide integral wall collar, continuously welded to pipe or sleeve, to control water seepage along the outside of the pipe or sleeve through the concrete wall.
 - c. Wall collar size per AWWA C115
 - d. Center wall collar in wall to avoid wall reinforcement.
 - 2. Wall pipes:
 - a. Connected to adjacent pipe per plans
 - b. Size per plan; match connecting piping.
 - 3. Wall sleeves:
 - a. Allow a carrier pipe to pass through wall sleeve.
 - b. Sleeve diameter per wall pipe modular seal manufacturer
 - c. Schedule 40 thickness (minimum)
- B. Materials:
 - 1. Wall Pipes: Match connecting piping, except provide ductile iron wall pipe for plastic connecting pipes.
 - 2. Wall Sleeves: AISI Type 316L Stainless Steel
- C. Finishes:
 - 1. Wall Pipes (interior and exterior): Conform to AWWA C210 or AWWA C116.
 - 2. Wall Sleeves: None

PART 3 EXECUTION

3.01 WALL PIPE MODULAR SEALS

- A. Install according to the manufacturer's written instructions and recommendations.
- B. Install on all pipes passing through wall sleeves in concrete walls.

3.02 WALL PIPES AND SLEEVES

- A. Provide wall pipes for all pipes passing through concrete walls or slabs, unless otherwise noted.
- B. Position wall pipes and sleeves in place with temporary, external supports. Prevent contact with reinforcement or other embedments.
- C. Inspect coatings prior to concrete placement. Repair any damage to the coating system in accordance with the manufacturer's written recommendations.
- D. Cast wall pipes and sleeves directly into concrete wall or slab. Wall blockouts are not allowed.

END OF SECTION

SECTION 15300

AUTOMATIC CONTROL VALVES

PART 1 GENERAL

1.01 SECTION INCLUDES

- A. Globe valves
- B. Check valves
- C. Solenoid control valves
- D. Pressure reducing valve
- E. Pressure relief valves
- F. Surge anticipated valves
- G. Pump control valves
- H. Altitude valves

1.02 RELATED REQUIREMENTS

- A. Section 09900, Painting and Coating
- B. Section 15042, Hydrostatic Testing of Pressure Pipelines
- C. Section 15056, Ductile-Iron Pipe and Fittings
- D. Section 15057, Copper, Brass, and Bronze Pipe Fittings and Appurtenances

1.03 REFERENCED STANDARDS

- A. ASTM International
 - 1. ASTM B62: Standard Specification for Composition Bronze or Ounce Metal Castings
- B. American Water Works Association
 - 1. AWWA C210: Liquid-Epoxy Coating Systems for the Interior and Exterior of Steel Water Pipelines
 - 2. AWWA C213: Fusion-Bonded Epoxy Coating for the Interior and Exterior of Steel Water Pipelines
 - 3. AWWA C550: Standard Test Method for Measuring Trueness and Squareness of Rigid Block and Board Thermal Insulation

- C. NSF International (NSF)
 - 1. NSF 61: Drinking Water System Components – Health Effects

1.04 SUBMITTALS

- A. Product data sheets
- B. Materials
- C. Pressure rating
- D. Shop drawings
- E. Hydraulic characteristic curves and data

PART 2 PRODUCTS

2.01 GENERAL

- A. All valves shall be complete, with all necessary operating appurtenances included in the work under this section.
- B. Valves shall have the name of the manufacturer and the size of the valve cast or molded onto the valve body or bonnet or shown on a permanently attached plate.
- C. Valve body and trim casting shall be of domestic origin.
- D. Bolts and nuts for flanged valves shall be Type 316 stainless steel in accordance with Section 15056.

2.02 GLOBE VALVE

- A. All control valve applications shall be based on a hydraulically operated, diaphragm-actuated, globe pattern valve. It shall contain a resilient, synthetic rubber disc, having a rectangular cross-section, contained on three and one-half sides by a disc retainer and forming a tight seal against a single removable seat insert. The diaphragm assembly contacting a valve stem shall be fully guided at both ends by a bearing in the valve cover and an integral bearing in the valve seat. This diaphragm assembly shall be the only moving part and shall form a sealed chamber in the upper portion of the valve, separating operating pressure from line pressure. The diaphragm shall consist of nylon fabric bonded with synthetic rubber and shall not be used as a seating surface. Packing glands and/or stuffing boxes are not permitted and there shall not be pistons operating the valve.
- B. Valve shall be of indicated size and shall be of manufacturer's standard ductile iron with stainless steel trim (seat, disc guide, cover bearing, stem nut, and stem). Valve shall have a pressure rating of 150 or 300 psi, depending on the service application, with the appropriate class ductile iron flanges.

- C. The design shall preclude cavitation erosion, fouling of working surfaces, and other effects adverse to reliability. Seats and other trim shall be secured by means precluding their loosening by hydraulically induced vibrations; and the fit of stems in guides and guide lengths shall preclude any binding, scraping, or deviation from true alignment affecting the free movement of working parts.
- D. All repairs shall be possible without removing the valve from the pipeline.

2.03 CHECK VALVE

- A. The check valve shall consist of a globe valve with the appropriate pilot system.
- B. The pilot shall contain auxiliary controls which permit the adjustment of the opening and closing speeds, and shall be set for fast opening and slow closing.
- C. Pilot valves shall be all bronze conforming to ASTM B62 with stainless steel trim. Hydraulic control and sensing lines shall be copper, conforming to Section 15057.

2.04 SOLENOID CONTROL VALVE

- A. The solenoid control valve shall consist of a globe valve with the appropriate pilot system.
- B. The pilot control shall be a solenoid valve controlling a diaphragm-operated three-way auxiliary valve. The control system shall include opening and closing speed controls, a wye strainer, and limit switch Model X105LCW.
- C. Pilot valves shall be all bronze conforming to ASTM B62 with stainless steel trim. Hydraulic control and sensing lines shall be copper, conforming to Section 15057, herein.

2.05 PRESSURE REDUCING VALVE

- A. The pressure reducing valve shall consist of a globe valve with the appropriate pilot system.
- B. The pilot control shall be a direct-acting, adjustable, spring-loaded, diaphragm valve, designed to permit flow when controlled pressure is less than the spring setting. The control system shall include a fixed orifice.
- C. The pilot valve system shall have a direct-acting, adjustable, spring-loaded pilot, diaphragm actuated valve, designed to permit flow in the pilot valve system whenever the controlling pressure exceeds the spring setting. The pilot valve system shall also contain a strainer needle valve assembly that shall control the opening of the main valve.
- D. Pilot valves shall be all bronze conforming to ASTM B62 with stainless steel trim. Hydraulic control and sensing lines shall be copper, conforming to Section 15057.

2.06 PRESSURE RELIEF VALVE

- A. The pressure relief valve shall consist of a globe valve with the appropriate pilot system.

- B. The pilot valve system shall have a direct acting, adjustable, spring-loaded pilot, diaphragm actuated valve, designed to permit flow in the pilot valve system whenever the controlling pressure exceeds the spring setting. The pilot valve system shall also contain a strainer needle valve assembly that shall control the closing of the main valve.
- C. Pilot valves shall be all bronze conforming to ASTM B62 with stainless steel trim. Hydraulic control and sensing lines shall be copper, conforming to Section 15057.

2.07 SURGE ANTICIPATOR VALVE

- A. The surge anticipator valve shall consist of a globe valve with the appropriate pilot system.
- B. The pilot control shall be a direct-acting, adjustable, spring-loaded, diaphragm valve. The pilot valve system shall contain a strainer needle valve assembly that shall control the closing of the main valve. The pilot valve system shall also contain a check valve that is installed on one of the main valve cover connections. This check valve shall be so installed that if low pressure occurs at the inlet of the valve, it will open and relieve the cover pressure to the inlet side of the valve.
- C. Pilot valves shall be all bronze conforming to ASTM B62 with stainless steel trim. Hydraulic control and sensing lines shall be copper, conforming to Section 15057.

2.08 PUMP CONTROL VALVE - BOOSTER TYPE

- A. This valve shall be a hydraulically operated, single seated, diaphragm actuated, composition disc, dual-port globe style valve with solenoid valve control. The valve shall have a built-in check feature; designed to operate with pump controls to start and stop the pump against a closed valve.
- B. Valves shall have emergency shutdown power check features for surge protection as described below: upon power failure, solenoids de-energize and a check valve in the diaphragm unit shall release to effect closure under spring action when flow stops before flow reversal can occur.
- C. Pilot valves shall be all bronze conforming to ASTM B62 with stainless steel trim. Hydraulic control and sensing lines shall be copper, conforming to Section 15057.
- D. A manual control override shall be provided on the valve assembly. The design shall preclude cavitation erosion, fouling of working surfaces, and other effects adverse to reliability. Seats and other trim shall be secured by means precluding their loosening by hydraulically induced vibrations; and the fit of stems in guides and guide lengths shall preclude any binding, scraping, or deviation from true alignment affecting the free movement of working parts.
- E. The valve shall be provided with a SPDT limit switch actuated by the control rod. The switch shall indicate:
 - 1. When the valve is fully closed
 - 2. When the valve is not fully closed

2.09 ALTITUDE VALVE

- A. The altitude valve shall consist of globe valve with the appropriate control system.

- B. The control system shall consist of auxiliary valves working in conjunction with the pilot valve to control the main valve. The pilot valve is to be controlled by the difference between the reservoir pressure and an adjustable spring pressure with a spring range of 5-40 feet of water. The entire valve and control assembly shall be designed so that no surface water can be drawn into the pilot system or the main valve at any time.

2.10 BOLTS AND NUTS FOR FLANGED VALVES

- A. Bolts and nuts for flanged valves shall be Type 316 stainless steel in accordance with Section 15056.

2.11 GASKETS

- A. Gaskets for flanged end valves shall be as described in Section 15056.

2.12 FACTORY FINISHES

- A. Coat all ferrous surfaces.
 - 1. Interior surfaces:
 - a. Fusion bonded epoxy meeting requirements of AWWA C213
 - b. Liquid-epoxy meeting requirements of AWWA C210 allowed for touch up and when valve design uses bonded rubber seats
 - c. Conform to requirements of NSF 61 for interior coatings.
 - 2. Exterior surfaces: factory primer

PART 3 EXECUTION

3.01 FIELD COATING

- A. Valve Exterior Surface, Above Grade or in Vault: Apply coatings per Section 09900. Coat all valve metal surfaces, except bronze and stainless steel surfaces.

3.02 VALVE LEAKAGE TESTING

- A. Test valves for leakage at the same time that the connecting pipelines are tested. See Section 15042 for pressure testing requirements.
- B. Valves shall have a pressure rating higher than or equal to the test pressure.
- C. All valves 16-inch and larger shall be hydrostatically shop tested to the valves working pressure in the presence of the District inspector. Each side of the valve shall be tested independently. Exterior epoxy shall be touched up as required. After testing, valves shall be palletized, shrink wrapped, and delivered to the job site.

3.03 MANUFACTURER'S SERVICES

- A. A manufacturer's representative for the equipment specified herein shall be present at the job site and/or classroom designated by the District for the minimum personnel days listed for the services hereunder, travel time excluded:
1. One (1) personnel day for equipment start up, and
 2. One (1) personnel-day for post start-up training
 3. Start up services and training of District's personnel shall be at such times as requested by the District.

END OF SECTION

**TABLE OF CONTENTS
STANDARD DRAWINGS**

<u>Dwg No.</u>	<u>Dwg Title</u>
G-GN	General Construction Notes
W-GN	General Potable Water Notes
W-1	Standard 3/4" & 1" Water Service
W-2	Standard Water Meter Manifold
W-3	Standard 1-1/2" & 2" Water Service
W-4	3", 4", 6", and 8" Standard Meter Commercial Continuous Flow Meter
W-5	3", 4", 6", and 8" Irrigation Meters
W-6	Hot Tap
W-7	Standard Fire Hydrant
W-8	Valve Assembly
W-9	Standard Combination Valve Assembly
W-10	Standard Temporary Plug and Blow-off Installation
W-11	Pipe Bedding
W-12	Typical Thrust Block
W-13	Steel Casing Pipe
W-14	Design Criteria for Separation of Recycled Water and Sewer Mains for New Potable Water Mains
W-15	Above Ground Private Fire Service
W-16	Conversion from Below Ground to Above Ground Private Fire Service
W-17	Backflow Prevention Device 2" and Smaller
W-18	Backflow Prevention Device 3" and Larger
W-19	Concrete Encasement and Slope Anchors
W-20	Guard Post Detail
W-21	Removable Post Detail
W-22	Hydrostatic Pressure Testing
W-23	Zinc Anode for Services and Air-Vacs
W-24	Above Ground and Buried Insulating Flange
W-25	Joint Bonding
W-26	Alumino-Thermic Weld
RW-GN	General Off-Site Recycled Water Notes
RW-1	Design Criteria for Separation of Potable Water and Sewer Mains for New Recycled Water Mains
S-GN	General Sewer Notes
S-1	Standard Manhole
S-2	Typical Concrete Base and Joint Details
S-3	Manhole Frame and Cover for 48" Manhole
S-4	36" Manhole Frame and Two Concentric Covers for 60" and 72" Manhole
S-5	PVC & VCP Pipe Bedding
S-6	Typical House Lateral
S-7	Typical Sewer Wye Connection
S-8	Concrete Encasement Type A, B & C

MOULTON NIGUEL WATER DISTRICT

S-9	Concrete Slope Anchors
S-10	Steel Casing Pipe
S-11	Design Criteria for Separation of Potable Water and Recycled Water Mains for New Sewer Mains
S-12	External Drop Manhole
S-13	Grease Interceptor Tank with Sample Box
S-14	Trash Enclosure

GENERAL CONSTRUCTION NOTES

1. THE CONTRACTOR SHALL BE IN POSSESSION OF TWO (2) COPIES OF APPROVED CONSTRUCTION PLANS PRIOR TO STARTING CONSTRUCTION, AND SHALL DEMONSTRATE PROOF OF THIS UPON REQUEST. A PRECONSTRUCTION CONFERENCE OF REPRESENTATIVES FROM AFFECTED AGENCIES AND THE CONTRACTOR SHALL BE HELD ON THE JOB SITE A MINIMUM OF 72 HOURS PRIOR TO START OF WORK.
2. THE CONTRACTOR SHALL NOTIFY THE DISTRICT INSPECTION SUPERVISOR AT THE MOULTON NIGUEL WATER DISTRICT AT (949) 425-3593 AT LEAST FIVE WORKING DAYS PRIOR TO CONSTRUCTION FOR INSPECTION.
3. THE FACILITY IMPROVEMENTS ARE TO BE INSTALLED BY THE APPLICANT. ALL WORK SHALL CONFORM TO THE DISTRICT'S "STANDARD SPECIFICATIONS FOR THE CONSTRUCTION OF POTABLE WATER, SEWER, AND RECYCLED WATER FACILITIES," AS LAST REVISED. THE CONTRACTOR SHALL HAVE A COPY OF THE PLANS AND APPLICABLE STANDARD SPECIFICATIONS ON THE JOB AT ALL TIMES.
4. THE CONTRACTOR SHALL NOTIFY UNDERGROUND SERVICE ALERT (USA) AT 811 A MINIMUM OF TWO WORKING DAYS PRIOR TO ANY EXCAVATION WORK.
5. ALL FACILITY CONNECTIONS, UTILITY CROSSINGS, AND PARALLEL UTILITIES THAT WOULD POTENTIALLY BE IMPACTED BY CONSTRUCTION ACTIVITIES SHALL BE POTHOLED AND FACILITY LOCATIONS AND ELEVATIONS VERIFIED PRIOR TO CONSTRUCTION. THE EXISTENCE AND LOCATION OF UNDERGROUND UTILITIES OR STRUCTURES SHOWN ON THESE PLANS SHOWN HEREON IS APPROXIMATE. IT IS THE RESPONSIBILITY OF THE CONTRACTOR TO VERIFY THE LOCATION OF UTILITIES IN THE FIELD TWO WEEKS PRIOR TO CONSTRUCTION AND COORDINATE ALL PHASES OF CONSTRUCTION WITH THE VARIOUS UTILITY COMPANIES INVOLVED. THE CONTRACTOR IS REQUIRED TO TAKE ALL DUE PRECAUTIONARY MEANS NECESSARY TO PROTECT THOSE UTILITY FACILITIES NOT SHOWN ON THESE PLANS. AS FIRST ITEM OF WORK, CONTRACTOR SHALL, BEFORE STARTING CONSTRUCTION:
 - 5.1. PROVIDE POTHOLE PLAN FOR REVIEW AND ACCEPTANCE PRIOR TO POTHOLING
 - 5.2. POTHOLE ENTIRE PROJECT EXTENTS INCLUDING:
 - 5.2.1. ALL POINTS OF CONNECTION
 - 5.2.2. ALL CROSSINGS
 - 5.2.3. ALL PARALLEL UTILITIES WITHIN 5- FEET OF NEW FACILITY (NOT LESS THAN ONE POTHOLE PER 25- FEET WHERE PARALLEL)
 - 5.3. SUBMIT POTHOLE REPORT SHOWING TOP, BOTTOM, AND WIDTH OF UTILITY
 - 5.4. BASED ON POTHOLING RESULTS, IDENTIFY ANY PORTIONS OF THE PROJECT THAT WILL REQUIRE RE-DESIGN.
 - 5.5. ALLOW 2 WEEKS FOR DISTRICT'S REVIEW AND APPROVAL INCLUDING REVIEW OF ANY REQUIRED RE-DESIGN.
6. THE CONTRACTOR SHALL PROTECT EXISTING UTILITIES IN PLACE, UNLESS OTHERWISE NOTED. THE CONTRACTOR SHALL BE RESPONSIBLE FOR THE EXPENSES ON ANY REPAIR OR APPROVED RELOCATION TO SAID FACILITIES. ANY RELOCATIONS OF EXISTING FACILITIES ARE SUBJECT TO APPROVAL BY DISTRICT STAFF.
7. CONSTRUCTION WATER MAY BE TAKEN ONLY AT LOCATIONS APPROVED BY MNWD. RECYCLED WATER SHALL BE USED FOR ALL BACKFILL, COMPACTION, AND CONSTRUCTION WATER REQUIREMENTS. A CONSTRUCTION METER AND VALVE SHALL BE INSTALLED AT A LOCATION ESTABLISHED BY MNWD. CONTRACTOR WILL BE PROVIDED WITH A 2 ½" OUTLET. CONTRACTOR WILL BE REQUIRED TO TRANSPORT WATER TO THE CONSTRUCTION SITE FOR USE AS NEEDED. CONTRACTOR SHALL CHECK-OUT A WATER METER FROM THE DISTRICT'S MAIN OFFICE (DEPOSIT REQUIRED) FOR RECYCLED WATER TRACKING PURPOSES. ALL DISTRICT WATER USED ON-SITE SHALL BE PROPERLY METERED WITH A METER OBTAINED FROM THE DISTRICT. THE USE OF JUMPERS IS NOT ALLOWED. METERS MUST BE INSTALLED PRIOR TO OCCUPANCY OF A DWELLING.
8. AN ENCROACHMENT PERMIT FROM THE COUNTY OR CITY HAVING JURISDICTION IS REQUIRED PRIOR TO ANY WORK WITHIN PUBLIC RIGHT_OF_WAY OR EASEMENT.
9. TRAFFIC CONTROL SHALL BE THE CONTRACTOR'S RESPONSIBILITY. CONTRACTOR SHALL SUBMIT PROPOSED TRAFFIC CONTROL PLANS TO THE CITY FOR REVIEW AND APPROVAL PRIOR TO OBTAINING AN ENCROACHMENT PERMIT AND COMMENCING WORK.
10. NO FACILITY IS TO BE BACKFILLED UNTIL INSPECTED BY THE DISTRICT.
11. THE CONTRACTOR IS RESPONSIBLE FOR MAINTAINING A 1' MINIMUM VERTICAL CLEARANCE FROM EXISTING UTILITIES AND SHALL FOLLOW MINIMUM SEPARATION REQUIREMENTS FROM THE CALIFORNIA DEPARTMENT OF PUBLIC HEALTH (WHICHEVER IS MORE STRINGENT), AS DEPICTED ON MNWD STANDARD DRAWINGS W-14 FOR NEW POTABLE WATER MAINS, S-11 FOR NEW SEWER MAINS, AND RW-1 FOR NEW RECYCLED WATER MAINS.
12. TRENCH BACKFILL FROM THE BOTTOM OF THE TRENCH TO THE AGGREGATE BASE SHALL BE COMPACTED TO NOT LESS THAN 90% RELATIVE DENSITY, AND THE AGGREGATE BASE AND THE TOP 6-INCH OF THE BACKFILL MATERIAL SHALL BE COMPACTED TO 95% RELATIVE DENSITY.
13. TUNNELING OF CURBS, GUTTER SIDEWALKS, CROSS-GUTTERS, AND OTHER STRUCTURES WHERE AN AIR VOID MAY BE CREATED WILL NOT BE PERMITTED. JACKING, PUSHING, AND BORING ARE ACCEPTABLE. CONCRETE REPLACEMENT SHALL BE TO THE NEAREST CONSTRUCTION JOINT.
14. UPON COMPLETION OF THE WORK, THE CONTRACTOR IS TO PROVIDE MNWD AND THE DEVELOPERS/APPLICANTS ENGINEER WITH AN AS-BUILT SET OF JOB PRINTS WITH TIE-DOWN MEASUREMENTS FOR ALL FACILITY ASSETS AND APPURTENANCES.
15. RECORD DRAWINGS SHALL BE SUBMITTED BY THE DEVELOPERS/APPLICANTS ENGINEER TO THE DISTRICT FOR REVIEW AND APPROVAL AT THE CONCLUSION OF CONSTRUCTION ACTIVITIES, AND WILL REFLECT ANY FIELD CHANGES AND INSPECTORS/CONTRACTORS FIELD NOTES.

GENERAL POTABLE WATER NOTES

1. ALL MNWD GENERAL CONSTRUCTION NOTES SHALL APPLY (PER MNWD STANDARD DRAWING G-GN).
2. WATER SERVICE MUST BE MAINTAINED TO ALL CUSTOMERS WITHIN THE CONSTRUCTION AREA AT ALL TIMES. IF THE PRIMARY SOURCE OF WATER IS INTERRUPTED, A TEMPORARY SECONDARY SOURCE SHALL BE SUPPLIED BY THE CONTRACTOR AND APPROVED BY THE MOULTON NIGUEL WATER DISTRICT. ANY EXPENDITURES INCIDENTAL THERE TO SHALL BE BORNE BY THE CONTRACTOR.
3. POTABLE WATER MAINS SHALL BE INSTALLED AFTER THE INSTALLATION OF CURB AND GUTTER AT SIX FEET OFF OF CURB FACE UNLESS SHOWN OTHERWISE ON PLANS, OR AS STAKED BY THE APPLICANT'S SURVEYOR AT A MINIMUM 50-FOOT STATIONING IF NOT WITHIN A ROADWAY.
4. NEW POTABLE WATER PIPE 12" AND SMALLER SHALL BE INSTALLED WITH A MINIMUM COVER OF 42" BELOW FINISHED SURFACE OR AS SHOWN ON PLANS (WHICHEVER IS GREATER). NEW POTABLE WATER PIPE GREATER THAN 12" SHALL BE INSTALLED WITH A MINIMUM COVER OF 48" BELOW FINISHED SURFACE OR AS SHOWN ON PLANS (WHICHEVER IS GREATER).
5. SHUT DOWN OF EXISTING POTABLE WATER MAINS SHALL BE SCHEDULED WITH AND PERFORMED BY THE DISTRICT. SCHEDULED SHUTDOWN SHALL BE REQUESTED AT LEAST 5 WORKING DAYS PRIOR TO REQUESTED OUTAGE TO THE DISTRICT.
6. DEWATERING OF THE WATER MAIN IS TO BE COORDINATED WITH MNWD STAFF. CONTRACTOR SHALL PUMP WATER INTO WATER TRUCK AND DISCHARGE INTO SEWER MANHOLE IN THE PRESENCE OF THE DISTRICT INSPECTOR.
7. ALL VALVES SHALL BE LOCATED OFF THE TEE UNLESS OTHERWISE APPROVED BY THE DISTRICT. AT INTERSECTIONS AND BUS STOPS WITH CONCRETE PADS, THE MAIN LINE SHALL BE ROPED TO AVOID CROSS GUTTER CONFLICT.
8. ALL NUTS AND BOLTS, INCLUDING VALVES, SHALL BE GRADE 316 STAINLESS STEEL. ALL BURIED FLANGES, VALVES AND FITTINGS SHALL BE WRAPPED WITH 10-MIL POLYETHYLENE SHEET.
9. THE CONTRACTOR SHALL BE RESPONSIBLE FOR BRINGING VALVE CANS TO GRADE AFTER FINAL PAVEMENT IS PLACED.
10. ACP SHALL BE REMOVED, HANDLED, AND DISPOSED OF IN A MANNER THAT KEEPS THE MATERIAL IN A NON-FRIABLE CONDITION. CONTRACTOR SHALL BE RESPONSIBLE FOR DISPOSAL OF ALL ACP REMOVED DURING CONSTRUCTION. CONTRACTOR SHALL FOLLOW ALL STATE AND FEDERAL REGULATIONS PERTAINING TO THE PROPER HANDLING, REMOVAL, AND DISPOSAL OF ACP AND SHALL BEAR ANY EXPENSES FOR HANDLING, REMOVAL, DISPOSAL, AND REMEDIAL CLEANUP ACTIVITIES. CONTRACTOR SHALL PROVIDE MNWD WITH THE MANIFEST PROPER ACP DISPOSAL.
11. NO TAPS OR OTHER CONNECTIONS SHALL BE MADE TO EXISTING DISTRICT WATER MAINS PRIOR TO CONDUCTING AN APPROVED PRESSURE AND BACTERIOLOGICAL TEST ON THE NEW WATER DISTRIBUTION SYSTEM. TAPPING SLEEVES SHALL BE PRESSURE TESTED IN AN APPROVED MANNER IN THE FIELD IN THE PRESENCE OF THE DISTRICT INSPECTOR, PRIOR TO TAPPING THE MAIN LINE. TAPPING OF THE MAIN LINE SHALL NOT PROCEED UNLESS A DISTRICT INSPECTOR IS PRESENT.
12. ALL WATER MAINS SHALL BE REQUIRED TO PASS PRESSURE, LEAKAGE, AND BACTERIOLOGICAL TESTS PER SECTION 15042 OF THE STANDARD SPECIFICATIONS OF THE MOULTON NIGUEL WATER DISTRICT PRIOR TO ACCEPTANCE. A TEMPORARY CONNECTION WILL BE REQUIRED TO FACILITATE THIS TESTING. DISINFECTING OF ALL WATER MAINS SHALL BE PER MNWD SPECIFICATION 15041. ALL WATERLINE TIE-INS SHALL BE MADE IN THE PRESENCE OF AN AUTHORIZED DISTRICT INSPECTOR. ALL CONNECTING PARTS SHALL BE SWABBED WITH A 5% CHLORINE SOLUTION (NSF APPROVED). POTABLE WATER SHALL BE USED TO FILL, PRESSURE TEST, AND DISINFECT WATER MAIN. ALL FLUSHING WATER SHALL BE CONVEYED TO SEWER MANHOLE AN AIR GAP WILL BE REQUIRED, THIS SHALL BE CONDUCTED IN THE PRESENCE OF THE DISTRICT INSPECTOR.
13. ALL 3/4" THROUGH 2" METERS AND CUSTOMER SERVICE VALVES WILL BE FURNISHED BY MOULTON NIGUEL WATER DISTRICT FOLLOWING PROOF OF PROJECT APPROVAL AND PAYMENT. THE CONTRACTOR SHALL INSTALL ALL METERS AND CUSTOMER SERVICE VALVES. THE CONTRACTOR SHALL EXPOSE ALL ANGLE METER STOPS AND PROPERLY LOCATE THE METER BOXES TO GRADE PRIOR TO REQUESTING INSPECTION OF THE METERS AND CUSTOMER SERVICE VALVES BY THE DISTRICT.
14. ALL METERS SHALL BE INSTALLED IN GRASS OR PLANTER AREAS AND ACCESSIBLE BY VEHICLE. ANY SERVICES LOCATED IN SIDEWALKS ARE SUBJECT TO ORANGE COUNTY PUBLIC WORKS OR APPROPRIATE GOVERNING AGENCY AND DISTRICT APPROVAL. ANY METERS LOCATED IN BANKS OF 4 SHALL BE MANIFOLDED PER MNWD STANDARD DRAWING W-2. ALL METER REGISTERS AND LIDS SHALL BE MARKED WITH ADDRESS IDENTIFICATION.
15. WHERE METERS AND METER BOXES ARE LOCATED WITHIN SLOPES, THE ANGLE METER STOPS SHALL BE SO LOCATED THAT THE METERS AND BOXES WILL BE PARALLEL AND FLUSH, RESPECTIVELY, WITH THE FINISHED STREET SURFACE. A RETAINING WALL MAY BE REQUIRED AROUND THE METER BOX.
16. INDIVIDUAL PRESSURE REGULATORS SHALL BE INSTALLED AND SET PER CALIFORNIA PLUMBING CODE OR APPROPRIATE GOVERNING AGENCY'S STANDARDS.
17. CURBS SHALL BE INSCRIBED WITH A 2-INCH HIGH "W" INDICATING LOCATIONS OF ALL POTABLE WATER SERVICES.

MOULTON NIGUEL WATER DISTRICT

GENERAL POTABLE WATER NOTES

W-GN
JANUARY 2019

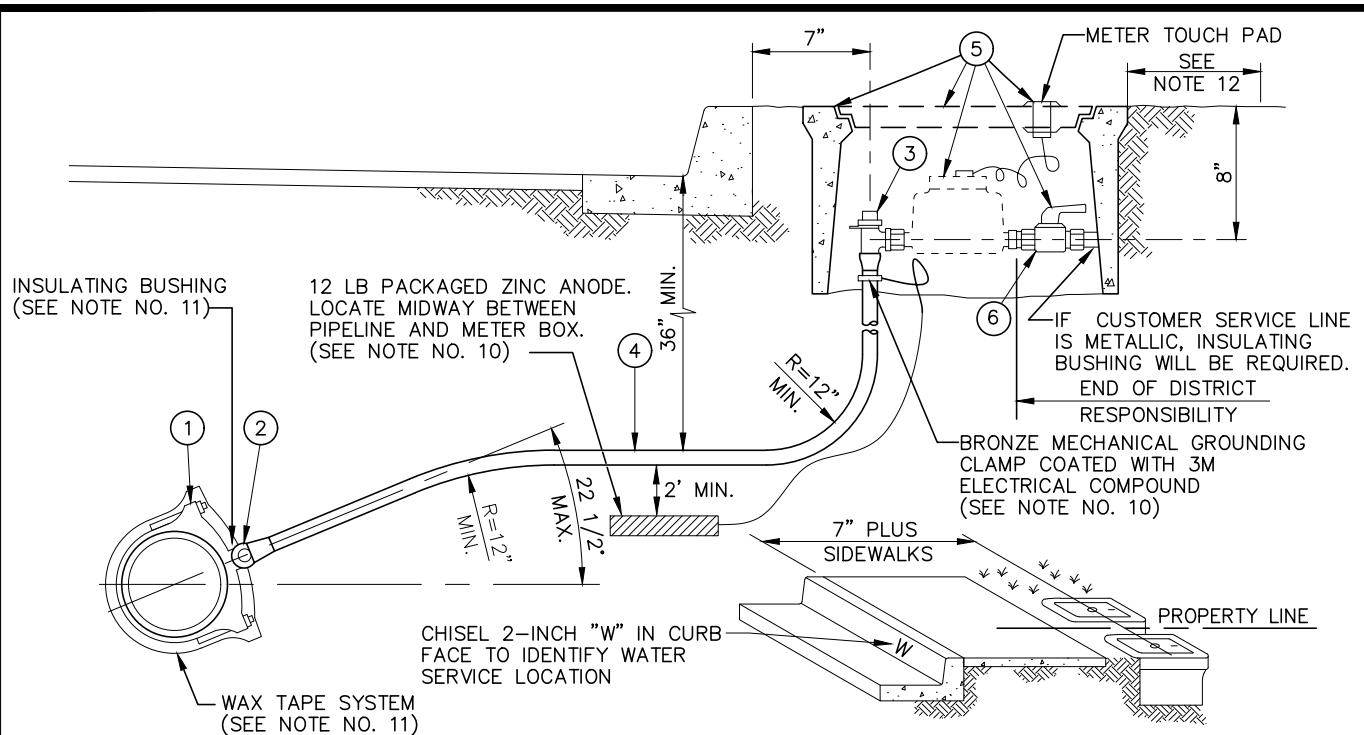

MATERIAL LIST		
ITEM	DESCRIPTION	COMMENTS
①	SERVICE SADDLE WITH I.P. THREAD	BRONZE
②	CORPORATION STOP (BALL TYPE)	I.P. THREAD X FLARE
③	ANGLE STOP (BALL TYPE)	FLARE ANGLE METER STOP
④	3/4" OR 1" COPPER TUBING	TYPE "K" SOFT
⑤	CUSTOMER METER, METER BOX, LID	PURCHASED FROM DISTRICT SET BY CONTRACTOR
⑥	CUSTOMER VALVE	PURCHASED FROM DISTRICT SET BY CONTRACTOR. METER FLANGE X F.I.P.

NOTES

- THE CORPORATION STOP TAP WILL BE MADE AS RECOMMENDED BY THE MANUFACTURER. ALL DRY TAPS WILL BE MADE BY SHELL CUTTER WITH GUIDE OR PILOT TAP.
- THE WATER SERVICE SHALL EXTEND PERPENDICULAR TO THE CENTERLINE OF THE STREET FROM THE WATER MAIN.
- SINGLE FAMILY RESIDENTIAL METERS SHALL BE LOCATED IN PAIRS AT PROPERTY LINE.
- WHEEL STOPS REQUIRED TO PREVENT VEHICLES FROM BLOCKING ACCESS TO WATER METERS.
- METER TO BE CENTERED INSIDE THE METER BOX.
- NO TAP TO MAIN SHALL BE WITHIN 18" OF A JOINT, FITTING OR ANOTHER TAP.
- SERVICE SHALL BE BACKFILLED WITH SAND, MIN. (SE 30) 6" BELOW AND ABOVE SERVICE.
- METER SIZE SHALL BE THE SAME AS THE SERVICE LINE.
- COPPER SERVICE LINE SHALL BE POLYETHYLENE SLEEVED.
- WATER SERVICES SHALL BE PROVIDED WITH A ZINC ANODE SYSTEM TO PROTECT FROM CORROSION.
- WATER SERVICES SHALL BE ISOLATED FROM STEEL AND DIP PIPELINES. PROVIDE A NYLON INSULATING BUSHING BETWEEN THE SERVICE SADDLE AND THE CORPORATION STOP. THE OUTLET SIZE ON THE SERVICE SADDLE SHALL BE INCREASED 1/2-INCH TO ACCOMMODATE THE BUSHING. WAX TAPE ON BRONZE OR STAINLESS STEEL SADDLE PER SECTION 13110. INSULATING BUSHING AND WAX TAPE REQUIRED FOR STEEL AND DIP MAINS ONLY.
- BOX SHALL BE LOCATED SO THAT MIN 12" CLEARANCE IS MAINTAINED FROM ADJACENT OBSTRUCTIONS ON ALL SIDES.

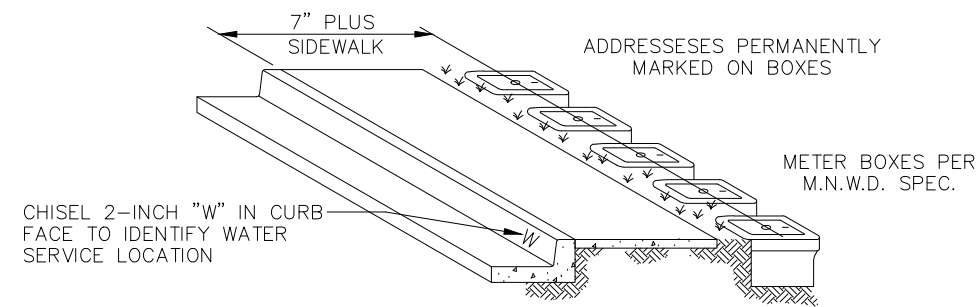

METER BOX INSTALLATION

MATERIAL LIST		
ITEM	DESCRIPTION	COMMENTS
①	SERVICE SADDLE	BRONZE
②	2" CORPORATION STOP (BALL TYPE)	I.P. THREAD X FLARE
③	2" ANGLE STOP	FLARE - GROUND ANGLE METER STOP
④	2" COPPER TUBING	TYPE "K" SOFT
⑤	METER, METER BOX, CUSTOMER VALVE	
⑥	2" 90° ELBOW	COPPER SWEAT FITTING
⑦	2" x 3/4" TEE	COPPER SWEAT FITTING
⑧	3/4" 90° ELBOW	COPPER SWEAT FITTING
⑨	3/4" COPPER	TYPE "K" SOFT
⑩	ANGLE STOP (BALL TYPE)	FLARE ANGLE METER STOP
⑪	2" WATER METER FLANGE	METER FLANGE X F.I.P.
⑫	2" ADAPTOR MIP X COPPER	COPPER SWEAT FITTING
⑬	2" X 3/4" REDUCER	

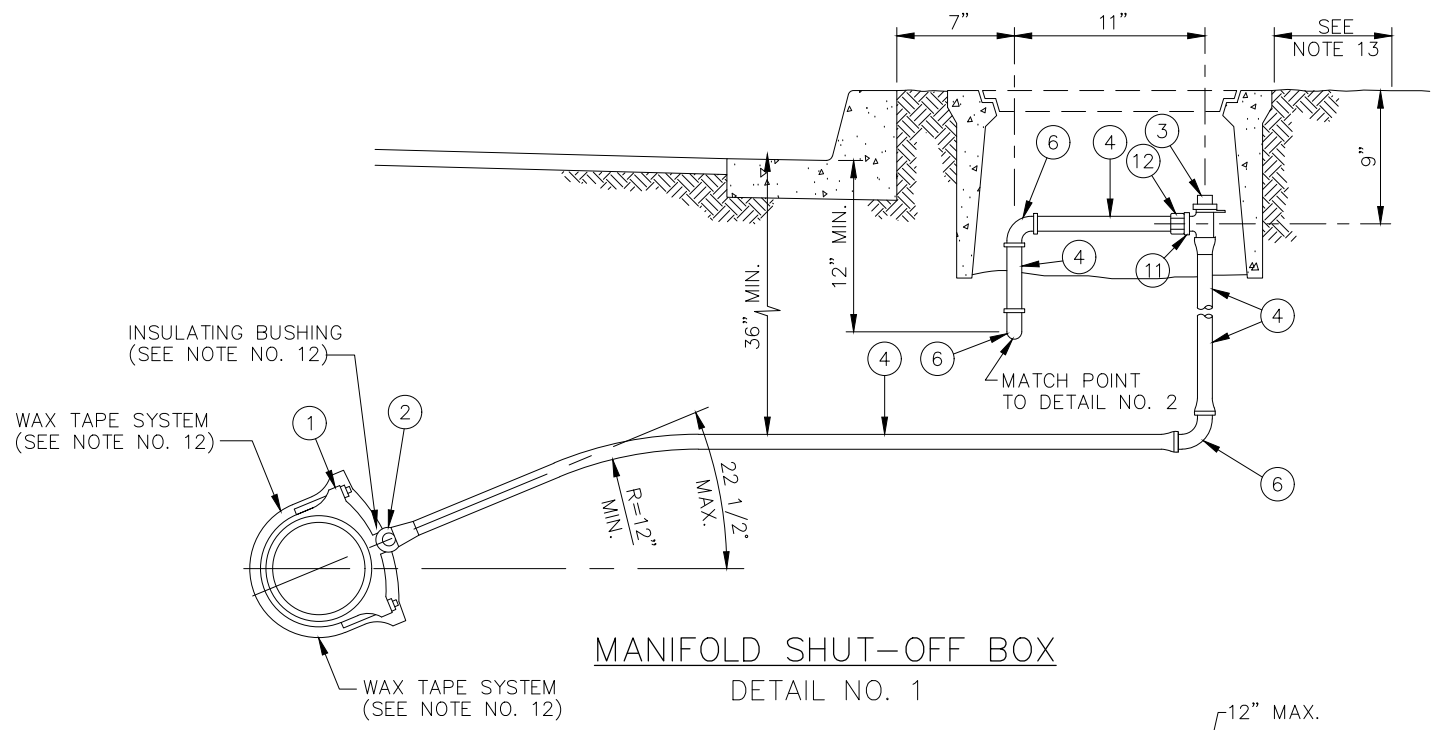

**MANIFOLD SHUT-OFF BOX
DETAIL NO. 1**

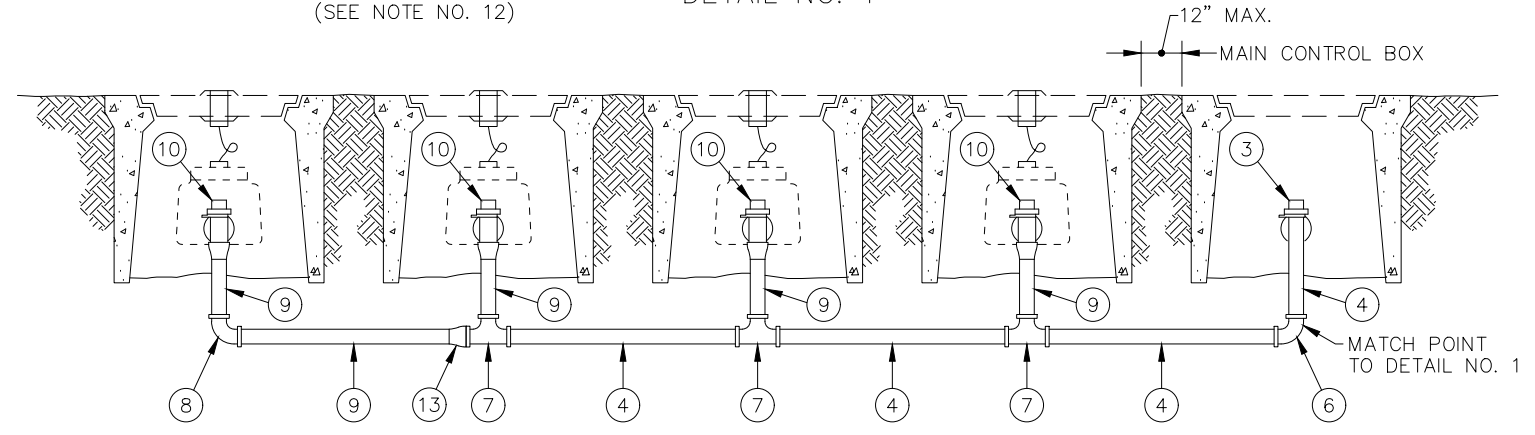

**4 METER MANIFOLD
DETAIL NO. 2**

NOTES

1. THE CORPORATION STOP TAP WILL BE MADE AS RECOMMENDED BY THE MANUFACTURER. ALL DRY TAPS WILL BE MADE BY HOLE SAW WITH GUIDE OR PILOT TAP.
2. THE WATER SERVICE SHALL EXTEND PERPENDICULAR TO THE CENTERLINE OF THE STREET FROM THE WATER MAIN.
3. SINGLE FAMILY RESIDENTIAL METERS SHALL BE LOCATED IN PAIRS AT PROPERTY LINE.
4. WHEEL STOPS REQUIRED TO PREVENT VEHICLES FROM BLOCKING ACCESS TO WATER METERS.
5. METER TO BE CENTERED INSIDE THE METER BOX.
6. NO TAP TO MAIN SHALL BE WITHIN 18" OF A JOINT, FITTING OR ANOTHER TAP.
7. SERVICE SHALL BE BACKFILLED WITH SAND, MIN. (SE 30) 6" BELOW AND ABOVE SERVICE.
8. METER SIZE SHALL BE THE SAME AS THE SERVICE LINE.
9. ALL COPPER FITTINGS SHALL BE SILVER SOLDER.
10. COPPER LINE SHALL BE POLYETHYLENE SLEEVED.
11. INSTALL ZINC ANODE SYSTEM PER STD. DWG. W-1 OR W-3 TO PROTECT FROM CORROSION.
12. WATER SERVICES SHALL BE ISOLATED FROM STEEL AND DIP PIPELINES. PROVIDE A NYLON INSULATING BUSHING BETWEEN THE SERVICE SADDLE AND THE CORPORATION STOP. THE OUTLET SIZE ON THE SERVICE SADDLE SHALL BE INCREASED 1/2-INCH TO ACCOMMODATE THE BUSHING. WAX TAPE ON BRONZE OR STAINLESS STEEL SADDLE PER SECTION 13110. INSULATING BUSHING AND WAX TAPE REQUIRED FOR STEEL AND DIP MAINS ONLY.
13. BOX SHALL BE LOCATED SO THAT MIN 12" CLEARANCE IS MAINTAINED FROM ADJACENT OBSTRUCTIONS ON ALL SIDES

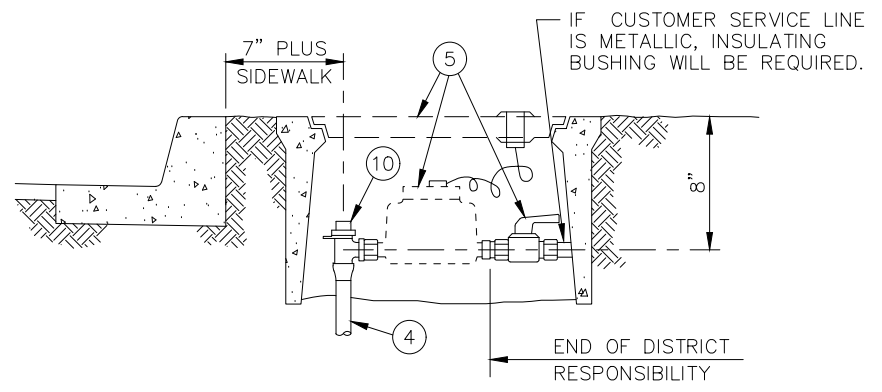

METER INSTALLATION

METER SIZE COMBINATION OPTIONS		
OPTION	METER SIZES	QUANTITY
A	1.5"	1
	1"	1
B	1.5"	1
	3/4"	2
C	1"	3
	3/4"	1
D	1"	2
	3/4"	2
E	1"	1
	3/4"	4
F	3/4"	6

MOULTON NIGUEL WATER DISTRICT

STANDARD WATER METER MANIFOLD

W-2
JANUARY 2019

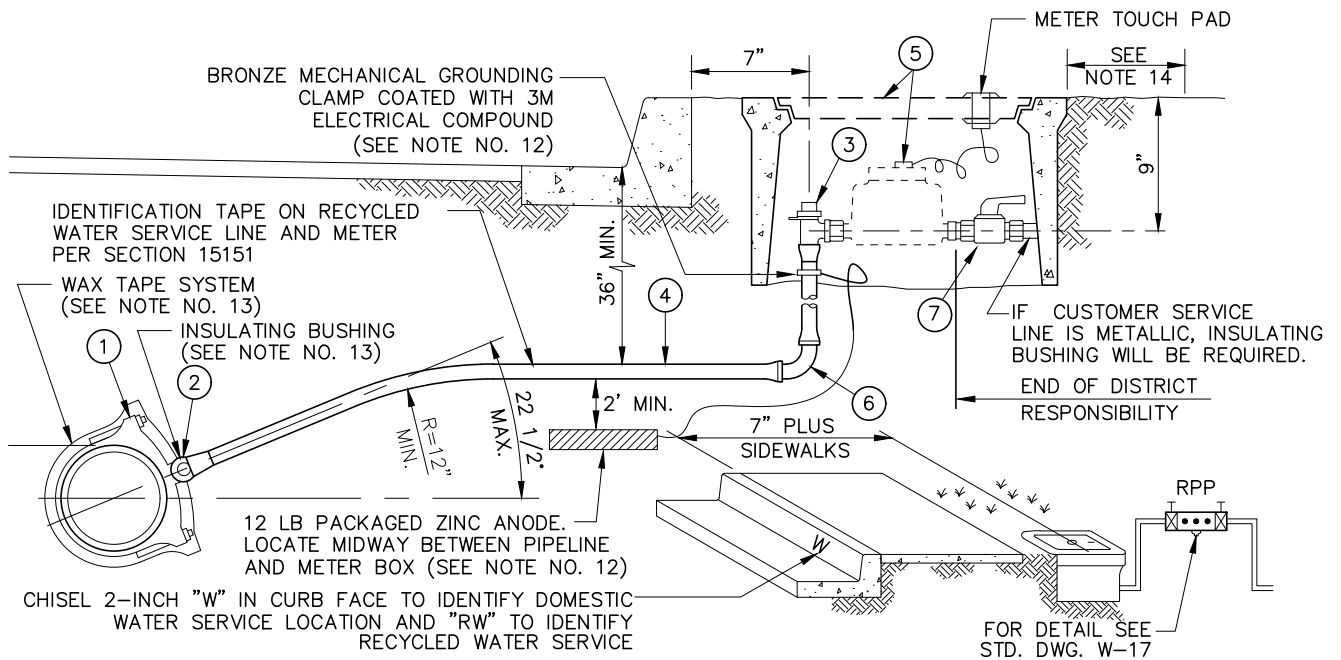

MATERIAL LIST		
ITEM	DESCRIPTION	COMMENTS
①	SERVICE SADDLE WITH I.P. THREAD	BRONZE
②	CORPORATION STOP (BALL TYPE)	I.P. THREAD X FLARE
③	ANGLE STOP	FLARE GROUND ANGLE METER STOP
④	1 1/2" OR 2" COPPER TUBING	TYPE "K" SOFT
⑤	CUSTOMER METER, METER BOX, AND LID	PURCHASED FROM DISTRICT SET BY CONTRACTOR
⑥	90°	COPPER SWEAT FITTING
⑦	CUSTOMER VALVE	PURCHASED FROM DISTRICT SET BY CONTRACTOR. METER FLANGE X F.I.P.

NOTES

- THE CORPORATION STOP TAP WILL BE MADE AS RECOMMENDED BY THE MANUFACTURER. ALL DRY TAPS WILL BE MADE BY MACHINE WITH GUIDE OR PILOT TAP.
- THE WATER SERVICE SHALL EXTEND PERPENDICULAR TO THE CENTERLINE OF THE STREET FROM THE WATER MAIN.
- METER TO BE CENTERED INSIDE THE METER BOX.
- WHEEL STOPS REQUIRED TO PREVENT VEHICLES FROM BLOCKING ACCESS TO WATER METERS.
- WHEN BACKFLOWS ARE REQUIRED, LOCATION WILL BE DETERMINED AT DISTRICT DISCRETION. GENERALLY BACKFLOW IS INSTALLED ADJACENT TO WATER METER.
- ALL 1 1/2" AND 2" SERVICES WILL BE LOCKED "OFF" AFTER NEW MAIN IS TIED IN.
- NO TAP TO MAIN SHALL BE WITHIN 18" OF A JOINT, FITTING OR ANOTHER TAP.
- SERVICE SHALL BE BACKFILLED WITH SAND, MIN. (SE 30) 6" BELOW AND ABOVE SERVICE.
- METER SIZE SHALL BE THE SAME AS THE SERVICE LINE.
- ALL COPPER FITTINGS SHALL BE SILVER SOLDER.
- ALL SERVICE LINES SHALL BE POLYETHYLENE SLEEVED.
- WATER SERVICES SHALL BE PROVIDED WITH A ZINC ANODE SYSTEM TO PROTECT FROM CORROSION.
- WATER SERVICES SHALL BE ISOLATED FROM STEEL AND DIP PIPELINES. PROVIDE A NYLON INSULATING BUSHING BETWEEN THE SERVICE SADDLE AND THE CORPORATION STOP. THE OUTLET SIZE ON THE SERVICE SADDLE SHALL BE INCREASED 1/2-INCH TO ACCOMMODATE THE BUSHING. WAX TAPE ON BRONZE OR STAINLESS STEEL SADDLE PER SECTION 13110. INSULATING BUSHING AND WAX TAPE REQUIRED FOR STEEL AND DIP MAINS ONLY.
- BOX SHALL BE LOCATED SO THAT MIN. 12" CLEARANCE IS MAINTAINED FROM ADJACENT OBSTRUCTIONS ON ALL SIDES.

CONSTRUCTION ITEMS

- ① COMMERCIAL CUSTOMER METER WITH RADIO TRANSMITTER UNIT
- ② FLANGED COUPLING ADAPTER
- ③ DUCTILE IRON SPOOL FLG x P.E., 1'-0" LONG
- ④ DUCTILE IRON FLANGED x P.E. SPOOL
- ⑤ DUCTILE IRON BLIND FLANGE
- ⑥ RESILIENT WEDGE VALVE, FLANGED, NRS WITH HANDWHEEL
- ⑦ PRECAST METEER VAULT - SEE TABLE W-4
- ⑧ I.P. SERVICE SADDLE
- ⑨ GALVANIZED LADDER
- ⑩ DUCTILE IRON FLG x FLG SPOOL
- ⑪ PRECAST CONCRETE VAULT COVER
- ⑫ PIPE SUPPORTS
- ⑬ PEA GRAVEL, 12" MINIMUM THICKNESS
- ⑭ 2" MIP X SWEAT ADAPTER
- ⑮ 2"-90° ELL SWEAT FITTING
- ⑯ 2" BALL CORPORATION STOP MIP X FIP VALVE
- ⑰ 2" COPPER (TYPE "K")
- ⑱ 2" BYPASS METER
- ⑲ 2" CHECK VALVE, METER FLANGE X FIP
- ⑳ 2" METER FLANGE X 2" FIP
- ㉑ TOUCH READ DEVICE (SEE INSTALLATION DETAIL)

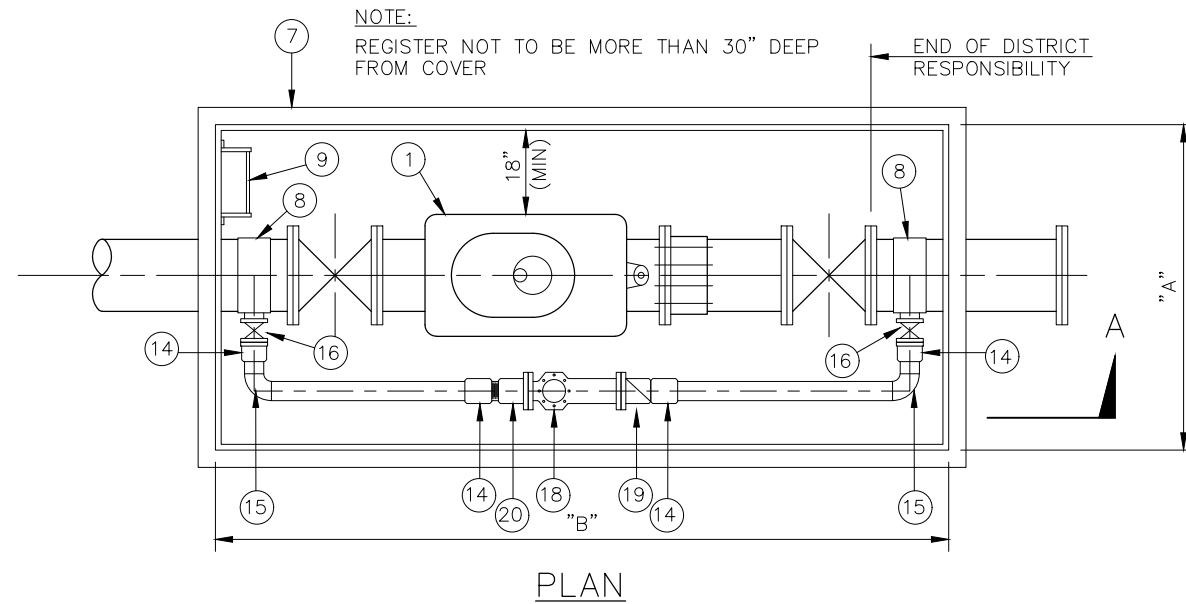

METER SIZE	VAULT SIZE (MIN.)	
	"A"	"B"
3"	4'	6.5'
4"	4'	6.5'
6"	5'	8.5'
8"	5'	8.5'

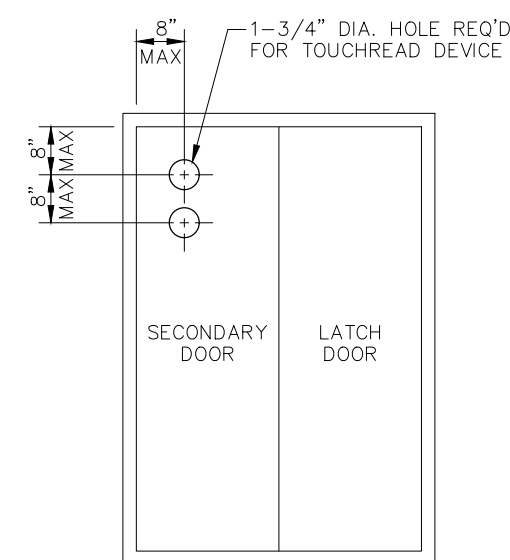
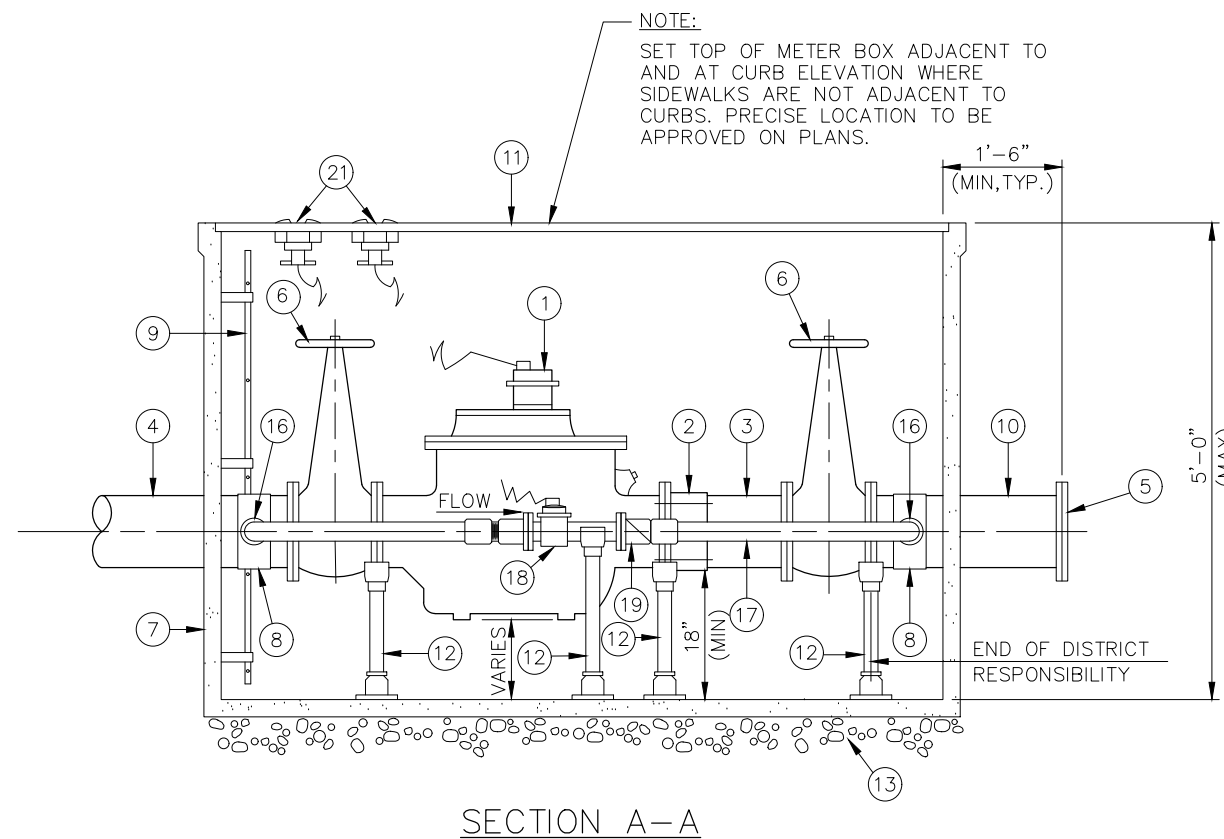

VAULT LID PLAN VIEW
FIG. 1

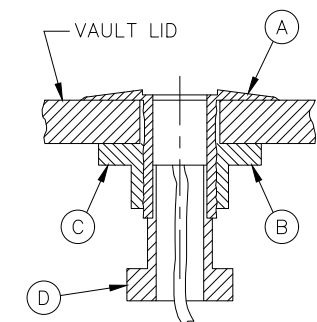

INSTALLING DEVICE

1. AS IN FIG. 1. DRILL 1-3/4" DIA. HOLE THROUGH VAULT LID
2. INSERT SENSOR HOUSING (A) THROUGH VAULT LID HOLE FROM ABOVE AND TIGHTEN SECURELY IN PLACE WITH PLASTIC NUT (B).
3. INSERT SENSOR ASSEMBLY (C) CONNECTED TO METERS REGISTER INTO HOUSING AND SECURE IN PLACE WITH SCREW PLUG (D).
4. EXCESS WIRE SHOULD BE COILED LOOSELY (NOT TIED) IN METER VAULT ALLOWING SLACK FOR VAULT LID TO SWING OPEN.

INSTALLATION DETAILS OF TOUCHREAD DEVICE

MOULTON NIGUEL WATER DISTRICT

3", 4", 6", AND 8" STANDARD METER
COMMERCIAL CONTINUOUS FLOW METER

W-4
JANUARY 2019

CONSTRUCTION ITEMS

- ① STRAINER
- ② IRRIGATION CUSTOMER METER WITH RADIO TRANSMITTER UNIT
- ③ 2" BRASS PLUG
- ④ 2" BALL CORPORATION STOP MIP X FIP
- ⑤ RESILIENT WEDGE VALVE, FLANGED, NRS WITH HANDWHEEL
- ⑥ PIPE SUPPORTS
- ⑦ 2" SERVICE SADDLE (INSTALLED MINIMUM 3 PIPE DIAMETERS FROM DOWNSTREAM SIDE OF METER)
- ⑧ FLG. x P.E. D.I.P. SPOOL
- ⑨ PRECAST CONCRETE VAULT
- ⑩ FLANGED COUPLING ADAPTER
- ⑪ TOUCH-READ DEVICE (SEE INSTALLATION DETAIL)
- ⑫ GALVANIZED LADDER
- ⑬ PEA GRAVEL, 12" MINIMUM THICKNESS
- ⑭ D.I.P. MAIN LINE, MIN. 6" DIA. PIPE FROM MAIN LINE TO VAULT

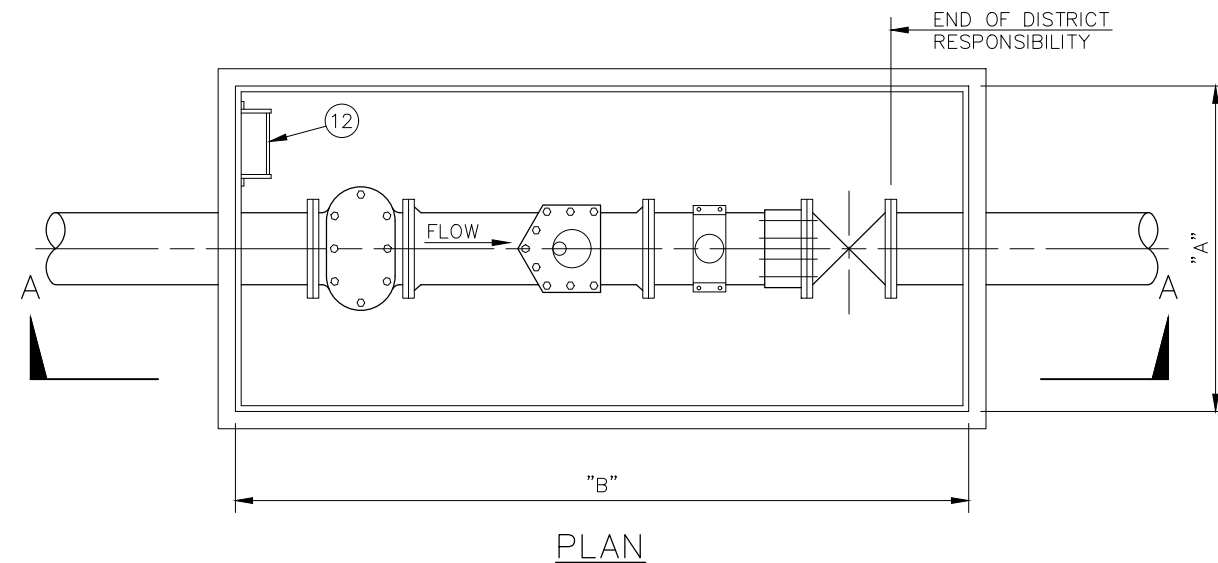

METER SIZE	VAULT SIZE (MIN.)	
	"A"	"B"
3"	4'	6.5'
4"	4'	6.5'
6"	5'	8.5'
8"	5'	8.5'

NOTE
IDENTIFICATION TAPE AND WARNING TAG ON RECYCLED WATER SYSTEM PER SECTION 15151

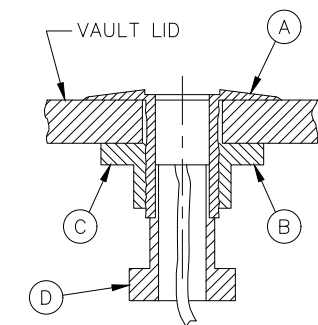
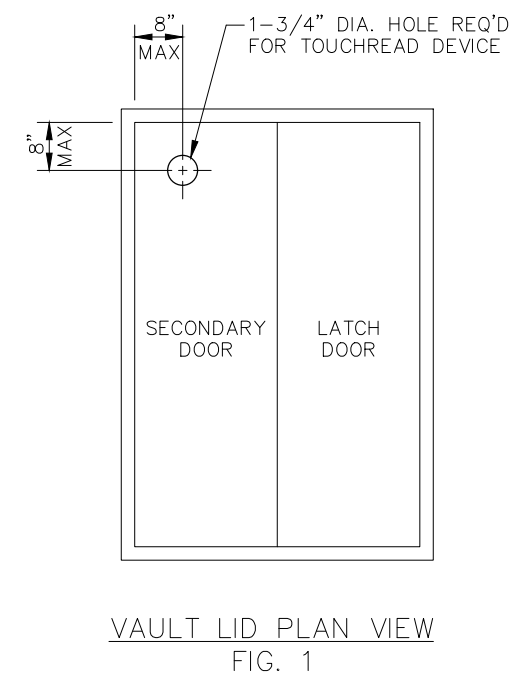
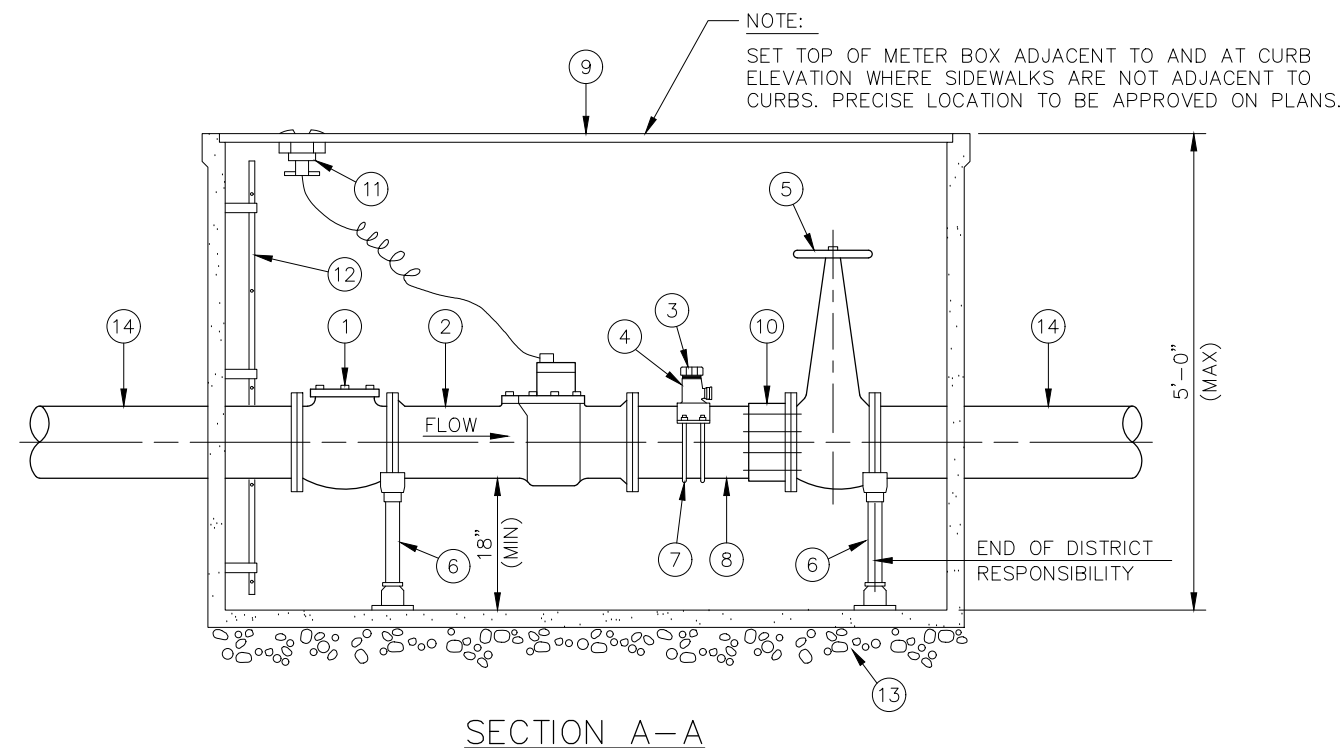

1. DRILL 1-3/4" DIA. HOLE THROUGH VAULT LID AS IN FIG. 1.
2. INSERT SENSOR HOUSING (A) THROUGH VAULT LID HOLE FROM ABOVE AND TIGHTEN SECURELY IN PLACE WITH PLASTIC NUT (B).
3. INSERT SENSOR ASSEMBLY (C) CONNECTED TO METERS REGISTER INTO HOUSING AND SECURE IN PLACE WITH SCREW PLUG (D).
4. EXCESS WIRE SHOULD BE COILED LOOSELY (NOT TIED) IN METER VAULT ALLOWING SLACK FOR VAULT LID TO SWING OPEN.

INSTALLATION DETAILS OF TOUCHREAD DEVICE

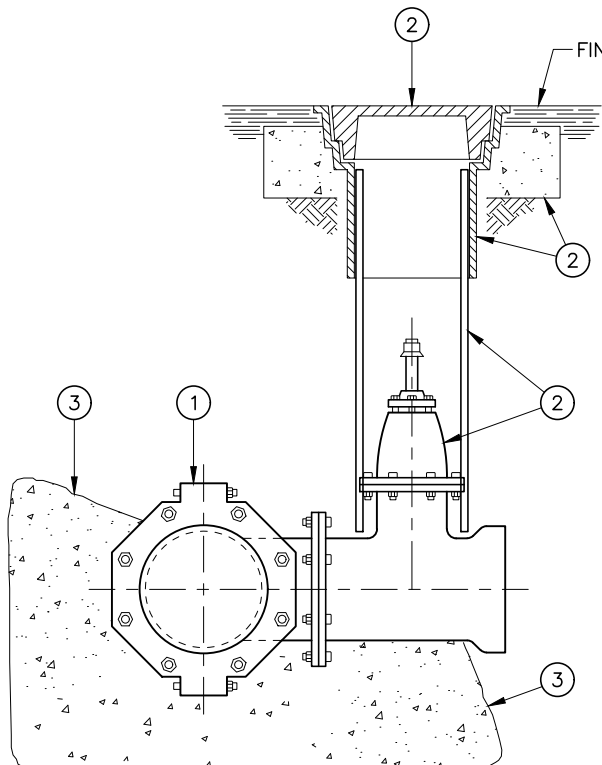

- ① TAPPING SLEEVE
- ② VALVE AND VALVE RISER BOX PER DWG. W-8. VALVE TO BE FLANGED X P.O. FULL PORT
- ③ CONSTRUCT CONCRETE THRUST BLOCK PER STD. DWG. W-12

NOTES

1. AIR TEST TAPPING SLEEVE PRIOR TO TAP
2. ALL BOLTS AND HARDWARE TO BE 316 S.S. COAT ALL TAPPING SLEEVE BOLTS WITH CORROSION GUARD
3. USE SHELL CUTTER ON ALL PVC TAPS
4. THE TAP SHALL NOT BE CLOSER THAN 18" TO A VALVE, COUPLING, JOINT, OR FITTING.

TAP OF ACP, PVC OR D.I.P. MAINS

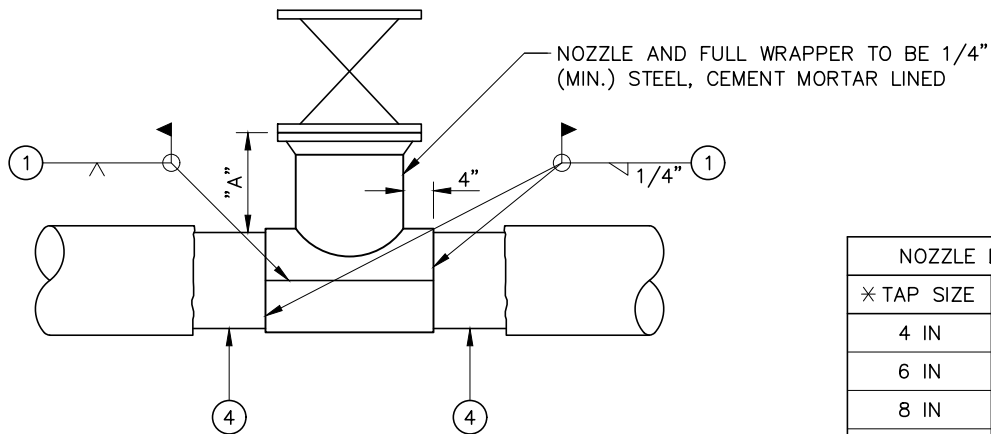

PLAN

NOZZLE DIMENSIONS	
× TAP SIZE	DIMENSION "A"
4 IN	5 IN
6 IN	6 IN
8 IN	6 3/4 IN
10 IN	7 IN
12 IN	7 1/2 IN

CONSTRUCTION STEPS

- ① WELD NOZZLE TO PIPE
- ② HYDROSTATIC TEST THE NOZZLE
- ③ TAP PIPE
- ④ INSTALL WIRE MESH AND MORTAR OVER EXPOSED STEEL

NOTE

1. CONTRACTOR TO PERFORM ALL POTHOLING, MEASUREMENTS, VERIFICATION OF MATERIALS, ETC. PRIOR TO ORDERING MATERIAL
2. THE TAP SHALL NOT BE CLOSER THAN 18" TO A VALVE, COUPLING, JOINT, OR FITTING.

TAP OF STEEL MAINS

NOTES

1. FIRE HYDRANT SHALL BE INSTALLED WITH 4" OUTLET PERPENDICULAR TO THE CURB FACE.
2. FIRE HYDRANT SHALL BE PAINTED PER SECTION 09900.
3. 4" GUARD POSTS MAY BE REQUIRED, AS DIRECTED BY THE DISTRICT.
4. WHERE SLOPE IS ADJACENT TO FIRE HYDRANT A RETAINING WALL MAY BE REQUIRED AS DIRECTED BY THE DISTRICT.
5. 12" MINIMUM CLEARANCE FROM FIRE HYDRANT TO EDGE OF SIDEWALK.
6. IF HYDRANT LATERAL IS 8" OR LARGER, THE HORIZONTAL DISTANCE BETWEEN REDUCER AND BURY EL SHALL BE NO MORE THAN 4".
7. SECURE TRACER WIRE BETWEEN ONE BOLT AND FLANGE WITH AN EXTRA 1" LOOP OF WIRE.

MATERIAL LIST	
ITEM	DESCRIPTION
①	RESIDENTIAL FIRE HYDRANT COMMERCIAL/INDUSTRIAL FIRE HYDRANT
②	6" LONG RADIUS CAST-IRON OR DUCTILE-IRON BURY EL (P.O. X FLG.)
③	6" PUSH-ON x FLG RESILIENT WEDGE VALVE
④	6" PUSH-ON x FLG TEE
⑤	6" BREAK-OFF CHECK VALVE, DUCTILE IRON
⑥	VALVE BOX AND RISER PER STD. DWG. W-8
⑦	6" DIA C.I. BREAK-OFF SPOOL

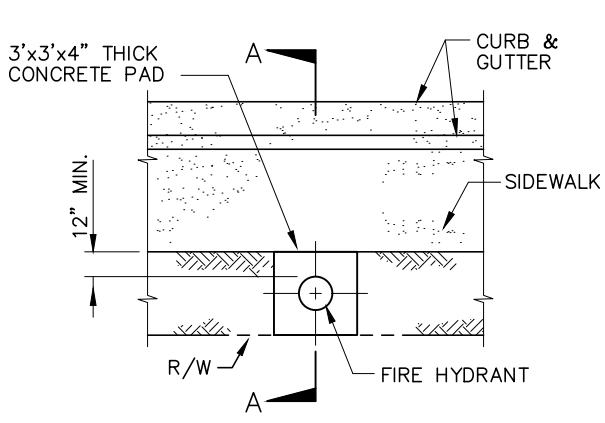
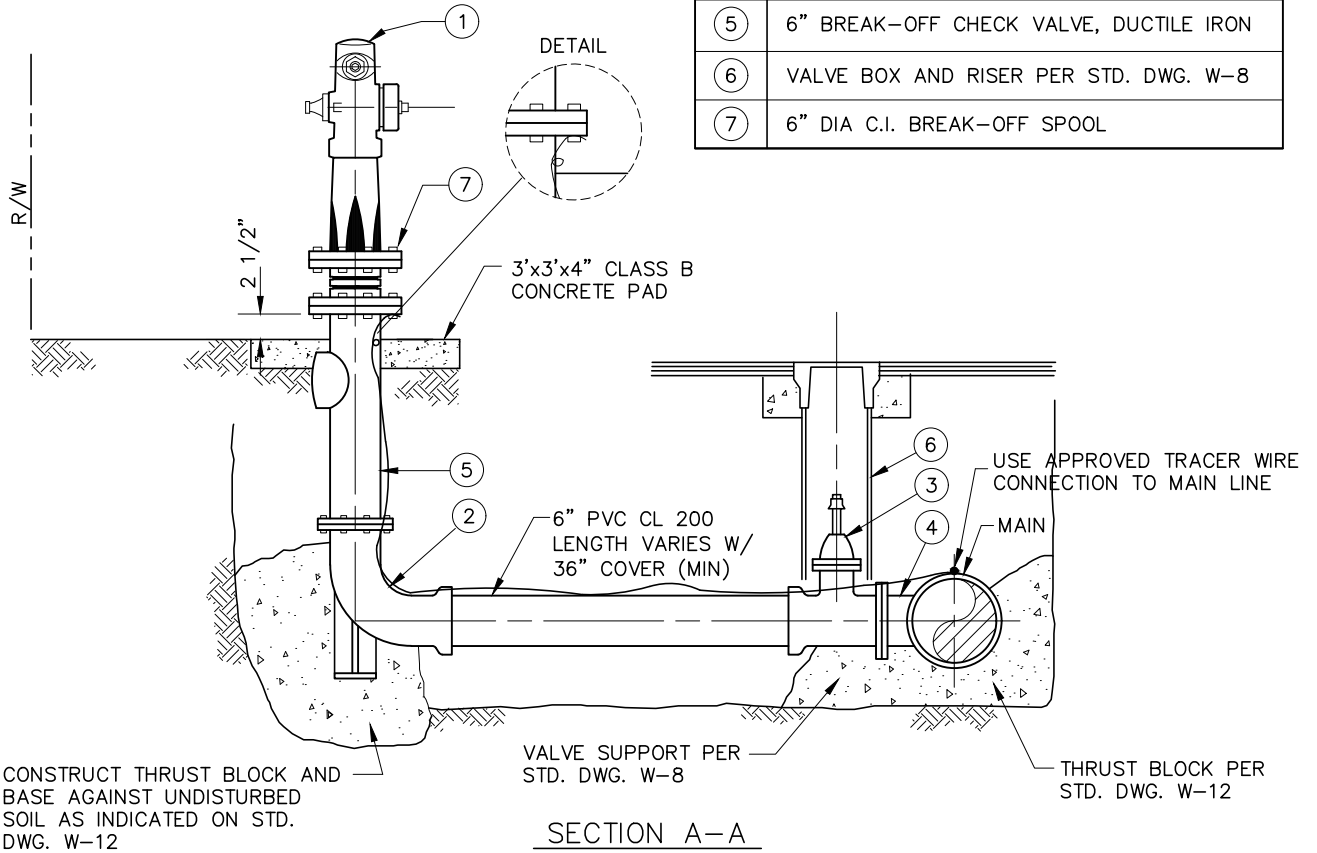

LOCATION PLAN WITH SIDEWALK

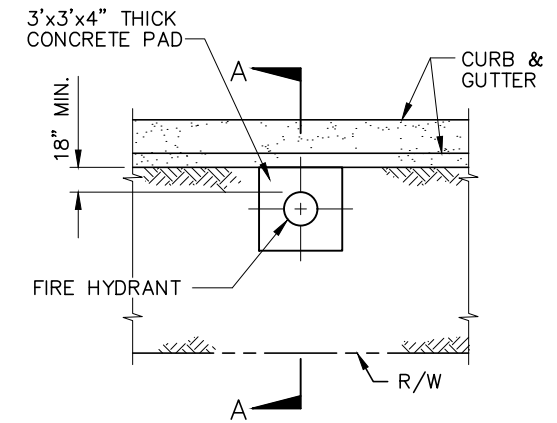

LOCATION PLAN WITHOUT SIDEWALK

FIRE HYDRANT LOCATION

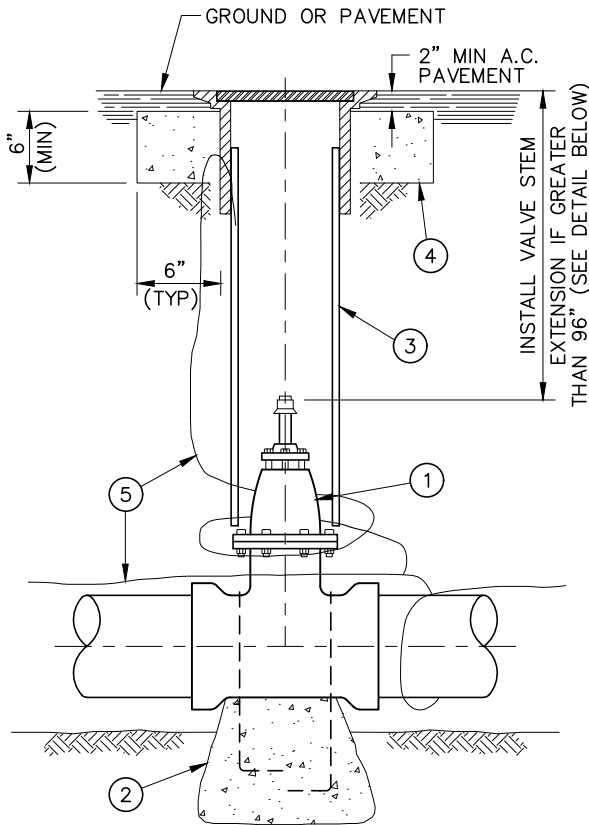

VALVE ASSEMBLY

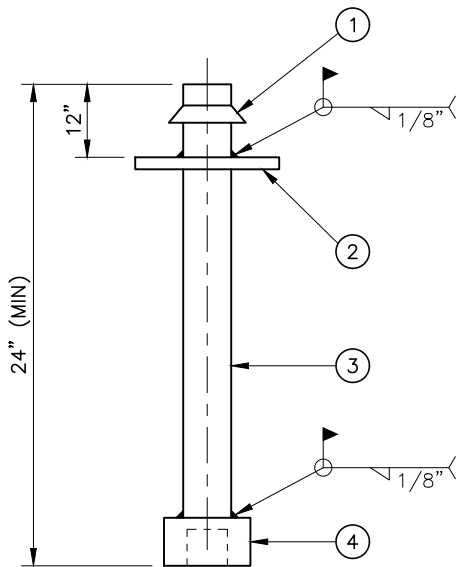

VALVE STEM EXTENSION

- ① RESILIENT WEDGE GATE VALVE
- ② CONCRETE VALVE ANCHOR BLOCK PER DWG W-12.
- ③ 8" SDR35 PVC VALVE RISER AND CAST IRON VALVE BOX. TOP MARKED PER NOTE 1.
- ④ CLASS B CONCRETE
- ⑤ NO. 10 GAGE LOCATING WIRE (PVC MAINS ONLY)

NOTES

1. VALVE BOX AND LID: COVERS WITH "WATER" ON POTABLE WATER SYSTEM AND "RECYCLED" ON RECYCLED WATER SYSTEM
2. ALL VALVE LOCATIONS SHALL BE CHISELED ON CURB FACE WITH 2-INCH HIGH "V".
3. ORIENT BUTTERFLY VALVE WITH OPERATOR TO THE RIGHT WHEN LOOKING TOWARD FITTING.
4. THE CONTRACTOR SHALL BE RESPONSIBLE FOR RAISING VALVE BOXES TO GRADE AFTER STREET IS PAVED 1ST LIFT, 2ND LIFT.
5. WHEN RAISING VALVE CANS, EXCAVATE TO RISER, CUT OFF SECTION OF EXISTING RISER, INSTALL NEW BELL-END 8" SDR 35 PVC RISER AT SUFFICIENT LENGTH TO ACCOMMODATE FINAL FINISHED SURFACE, AND INSTALL VALVE BOX. SCORE PLAIN-END OF RISER TO ACCOMMODATE VALVE BOX. IN LIEU OF BELL END PIPE, A PLAIN-END RISER AND BANDED FLEXIBLE COUPLING WITH 316 SST STRAPS MAY BE USED.

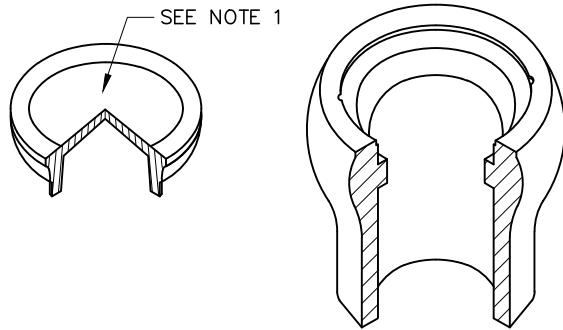

VALVE BOX

- ① A.W.W.A. 2" SQUARE OPERATING NUT
- ② 5" DIA. x 3/16" SPACER PLATE 12" BELOW TOP OF OPERATING NUT
- ③ 1 1/4" STAINLESS ROUND OR SQUARE STOCK (PINNED COUPLERS ARE NOT ALLOWED)
- ④ SOCKET FOR 2" SQUARE OPERATING NUT

NOTES

1. PROVIDE VALVE STEM EXTENSION WHEN DEPTH TO TO VALVE NUT EXCEEDS 96" INCHES (FABRICATE EXTENSION TO FIELD MEASUREMENT - SEE NOTE 2)
2. NO VALVE STEM EXTENSION SHALL BE LESS THAN 24" IN LENGTH. TERMINATE EXTENSION 24" TO 30" FROM FINISHED GRADE.
3. PROVIDE ADDITIONAL SPACER PLATE WHEN DISTANCE TO BOTTOM SOCKET EXCEEDS 5 FEET.

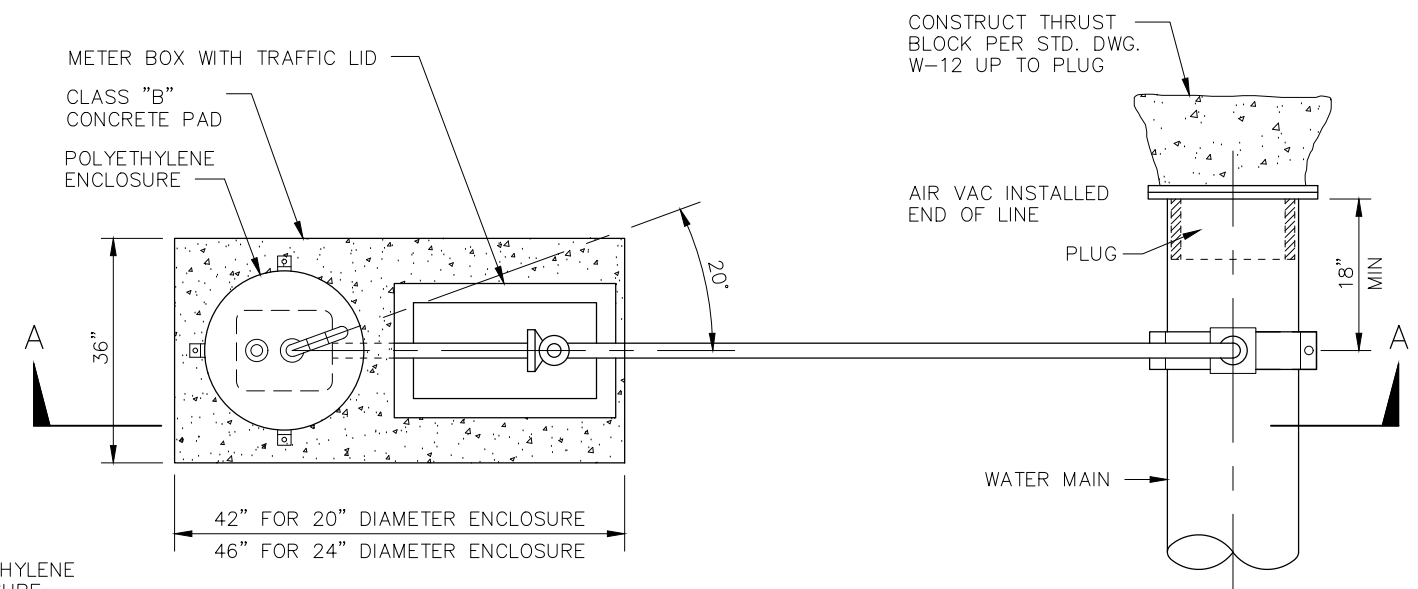
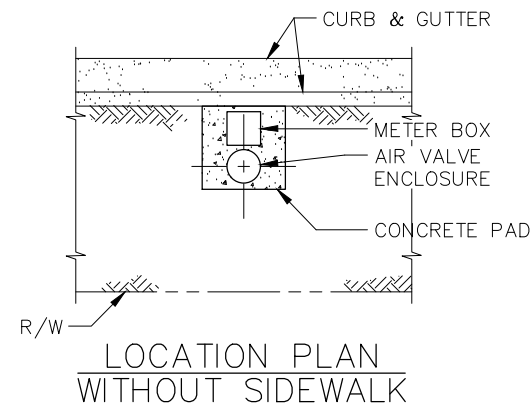
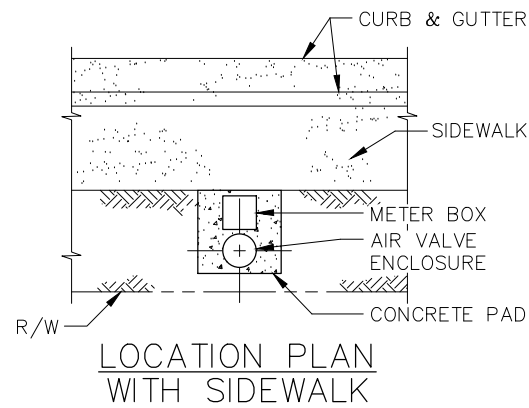

MATERIAL LIST FOR 1" AND 2"		
ITEM	DESCRIPTION	MATERIAL
①	COMB. AIR RELIEF & VACUUM RELEASE VALVE	REINFORCED NYLON
②	STRAP SERVICE SADDLE	BRONZE
③	90° STREET ELBOW	BRASS
④	CORPORATION STOP	
⑤	TUBING	TYPE "K" COPPER
⑥	ANGLE METER STOP	BRONZE
⑦	NIPPLE	BRASS
⑧	90° ELBOW	BRASS
⑨	BALL VALVE WITH HANDLE	BRONZE
⑩	SHORT NIPPLE	BRASS
⑪	NOT USED	-
⑫	DISCHARGE OUTLET	POLYPROPYLENE
⑬	NOT USED	-
⑭	TEE	BRASS
⑮	SHORT NIPPLE	STAINLESS STEEL
⑯	4" DIA x 8" LONG PVC PIPE SPOOL	SCH 80 PVC

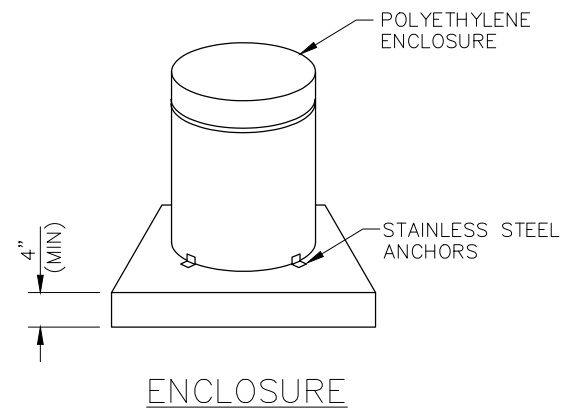

"WARNING TAG" FOR RECYCLED WATER MAIN

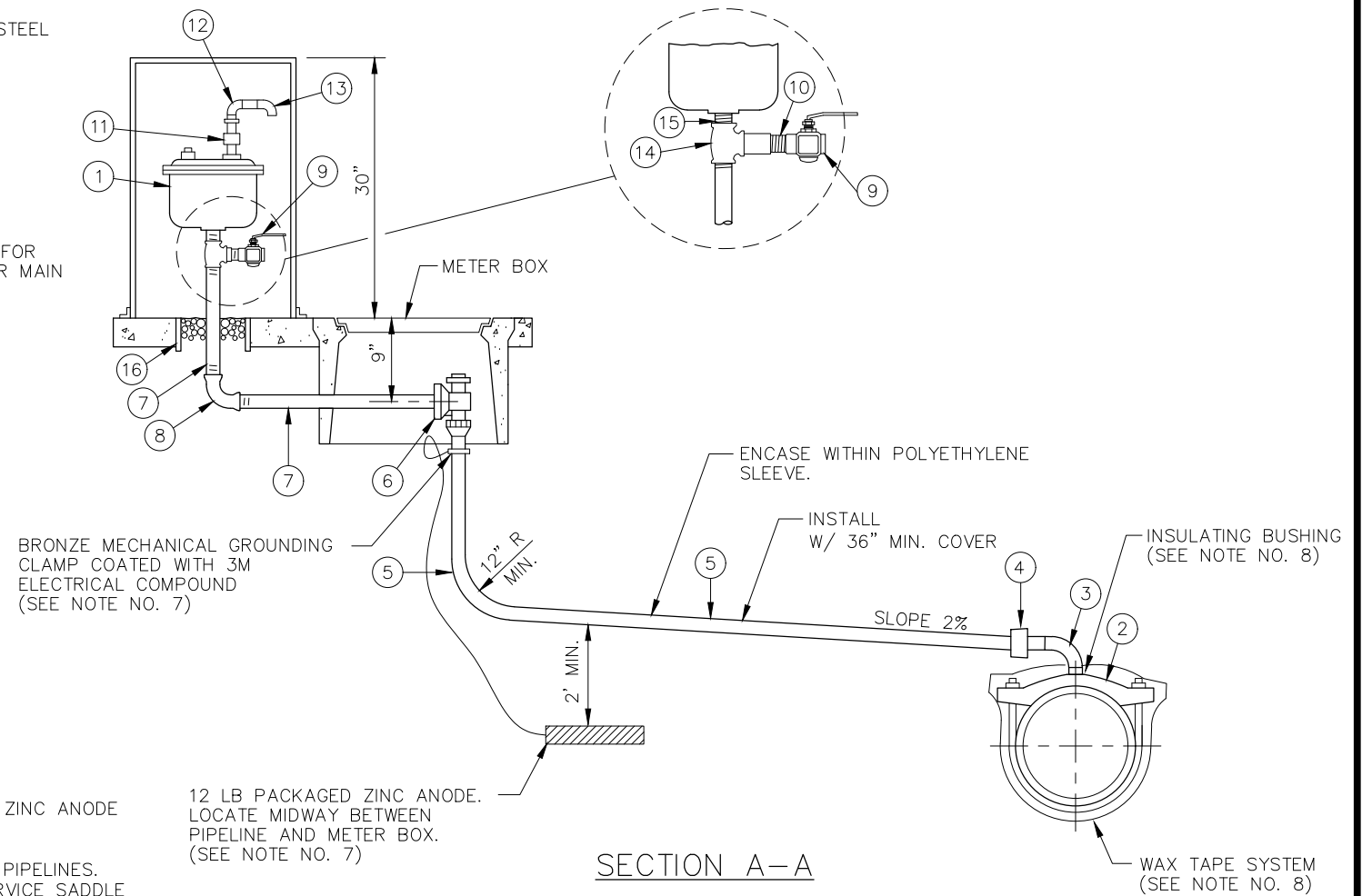

NOTES

- FOR PIPELINES LARGER THAN 10" THE DISTRICT WILL DETERMINE SIZE OF AIR AND VACUUM RELEASE VALVE.
- RETAINING WALL MAY BE REQUIRED WHEN ADJACENT TO SLOPES.
- FURNISH FITTINGS OF LIKE MATERIAL AS REQUIRED.
- SEE PROJECT PLAN DETAIL FOR MATERIAL LIST FOR ASSEMBLIES 3" AND LARGER.
- ORIENT OUTLET ON TOP OF PIPE.
- INSTALL IDENTIFICATION TAPE ON SERVICE LINE AND WARNING TAG ON BALL VALVE FOR RECYCLED WATER SYSTEM PER SECTION 15151.
- COPPER LINE SHALL BE POLYETHYLENE SLEEVED.
- COMB. AIR VALVE ASSEMBLY SHALL BE PROVIDED WITH A ZINC ANODE SYSTEM TO PROTECT FROM CORROSION.
- ISOLATE COPPER TUBING LATERALS FROM STEEL AND DIP PIPELINES. PROVIDE A NYLON INSULATING BUSHING BETWEEN THE SERVICE SADDLE AND THE CORPORATION STOP. THE OUTLET SIZE ON THE SERVICE SADDLE SHALL BE INCREASED 1/2-INCH TO ACCOMODATE THE BUSHING. WAX TAPE OF BRONZE SADDLE PER SECTION 13110. INSULATING BUSHING AND WAX TAPE REQUIRED FOR STEEL AND DIP MAINS ONLY.
- FILL 8" DIA PVC COLLAR WITH 8" OF 3/4" CRUSHED ROCK.

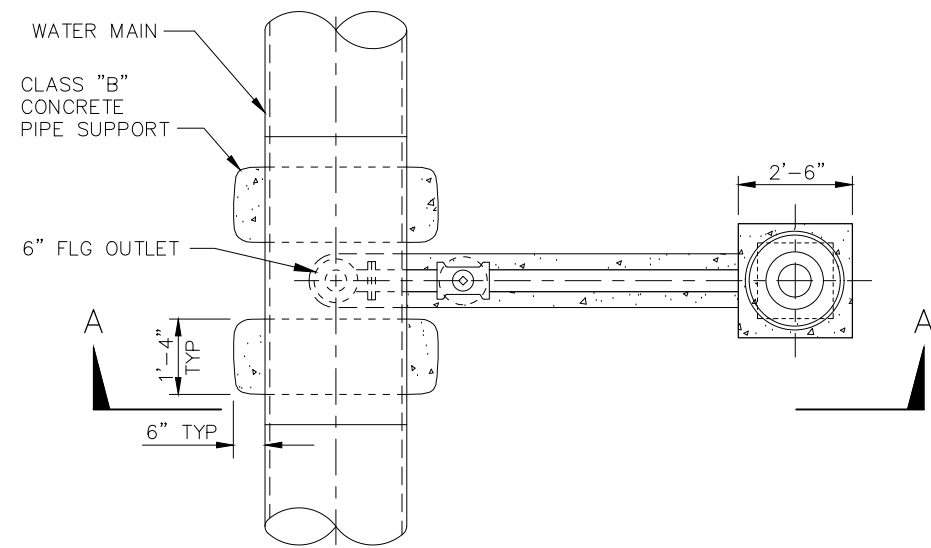

PLAN

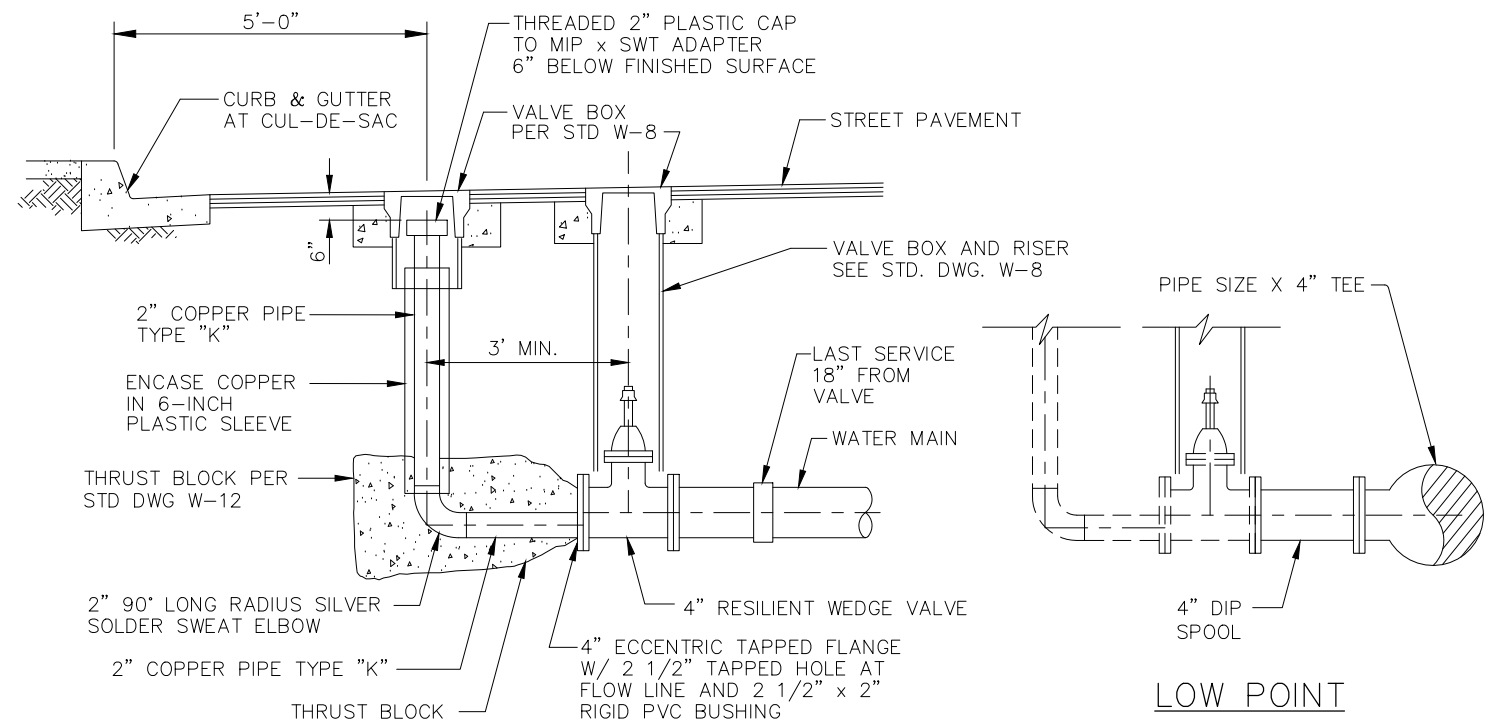

DEAD-END

LOW POINT

BLOW-OFF FOR DEAD-END STREET OR LOW POINT IN PIPELINE

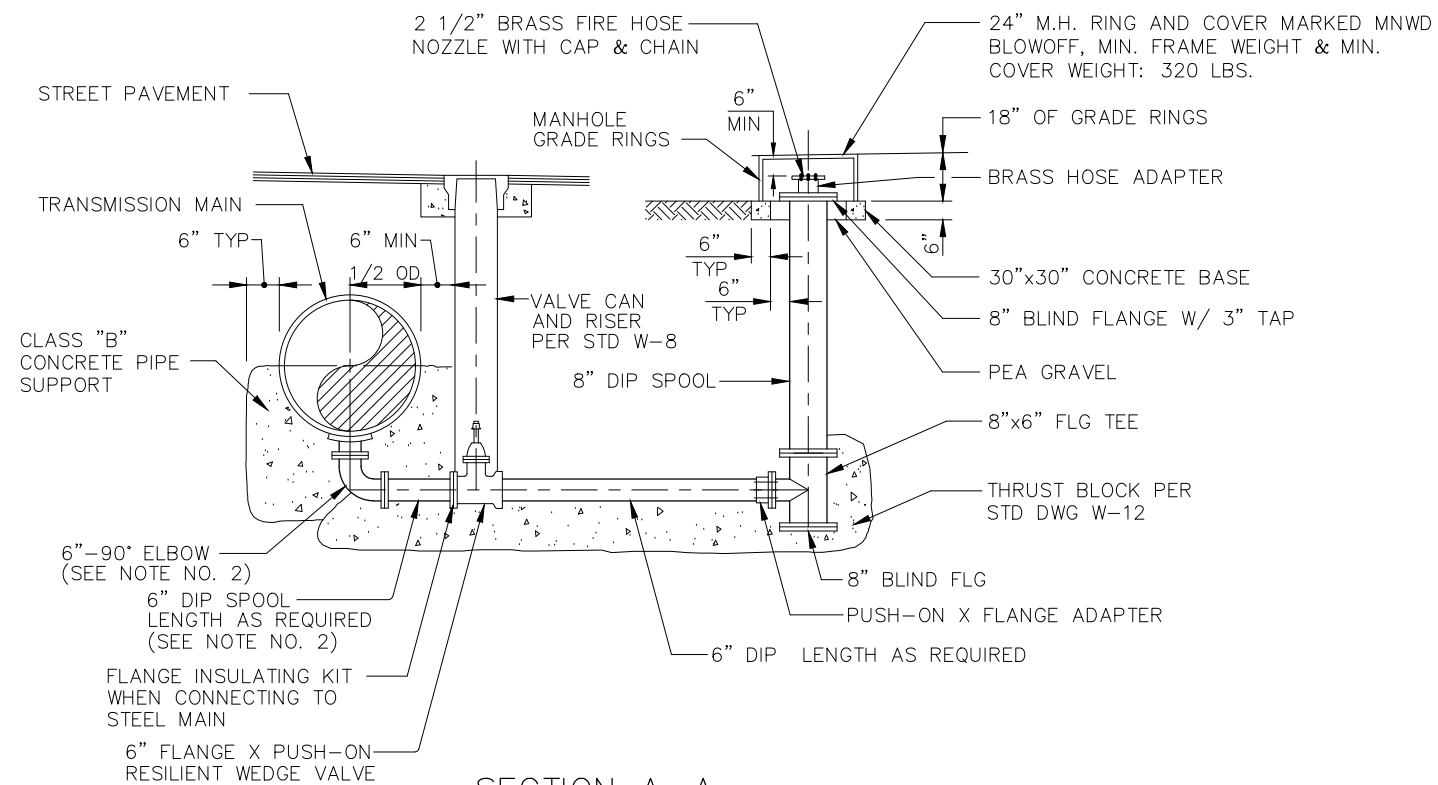

SECTION A-A

6" BLOW-OFF FOR LOW POINT OF LINE FOR WATER MAINS 12" DIA. AND LARGER

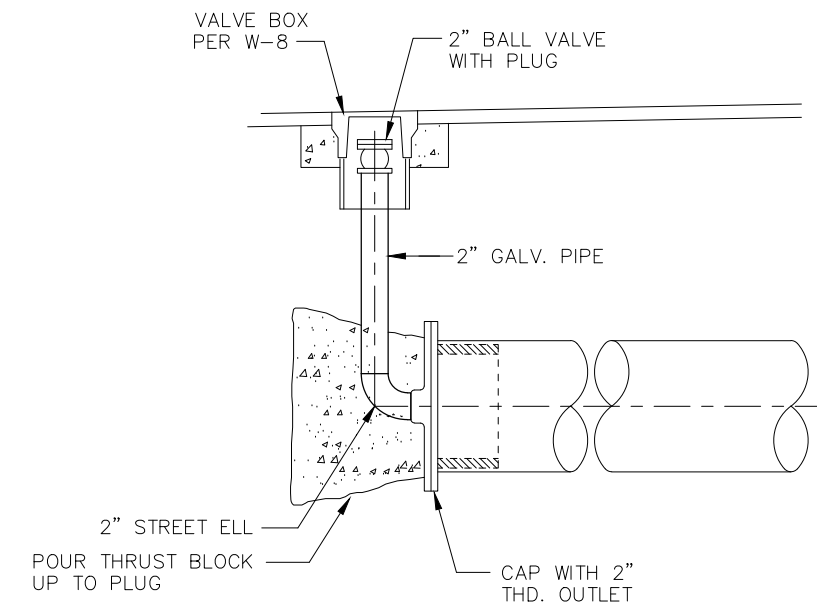

TEMPORARY PLUG & BLOWOFF

NOTES:

1. INSTALL IDENTIFICATION TAPE ON PIPING AND WARNING TAG ON OUTLET CAP AND PLUG FOR RECYCLED WATER SYSTEM PER SECTION 15151.
2. WHEN CONNECTING TO STEEL MAIN, THE 90° ELBOW AND SPOOL SHALL BE STEEL. INSTALL BOND WIRES ACROSS STEEL FLANGES UPSTREAM OF VALVE PER STD. DWG. NO. W-24. WAX TAPE BURIED EXPOSED STEEL SURFACES.

MOULTON NIGUEL WATER DISTRICT

STANDARD TEMPORARY PLUG AND BLOW-OFF INSTALLATION

W-10
JANUARY 2019

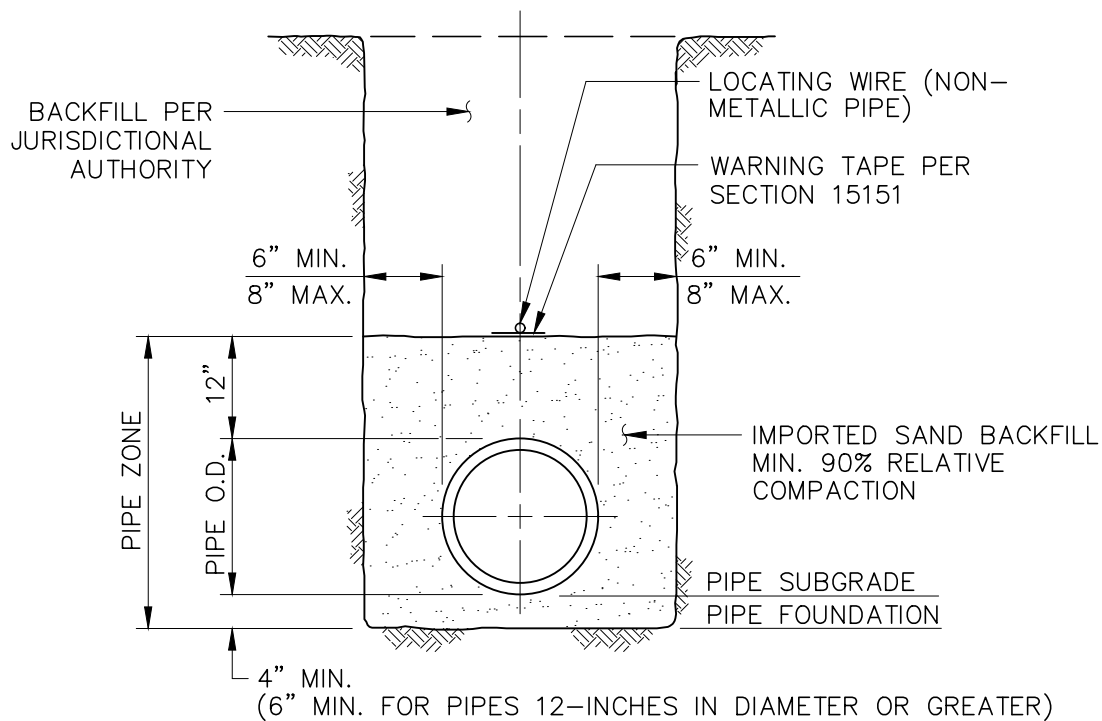

TYPICAL BEDDING

NOTE:

OVEREXCAVATE TO REMOVE UNSUITABLE SOIL IF NECESSARY AND REESTABLISH GRADE WITH 3/4" CRUSHED ROCK. DISTRICT TO DETERMINE DEPTH AND WIDTH OF REMOVAL.

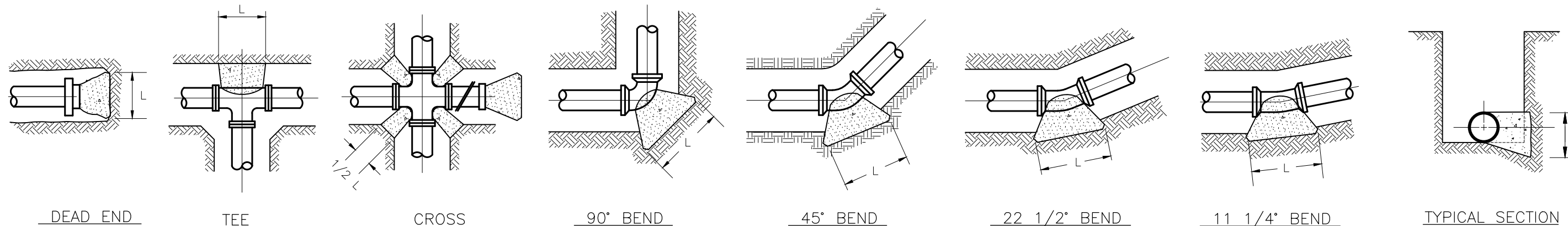

GENERAL NOTES

1. PROVIDE CLASS B CONCRETE. PRESSURE TEST SHALL BE PERFORMED IN ACCORD WITH CONCRETE CURING REQUIREMENTS.
2. THRUST BLOCKS SHALL BEAR AGAINST UNDISTURBED SOIL.
3. BEARING AREAS 'L' X 'H' ARE COMPUTED FOR TEST PRESSURES OF 225 PSI IN MAINS LAID IN A COHESIONLESS SOIL (C=0) WITH INTERNAL ANGLE OF FRICTION OF 37°, A UNIT WEIGHT OF 110 PCF, AND AT LEAST 36" OF COVER.
4. BEARING AREAS 'L' X 'H' SHALL BE APPROVED BY THE DISTRICT WHERE MAINS: (A) BEAR AGAINST WEAKER SOIL THAN DESCRIBED ABOVE, (B) HAVE LESS THAN 36" OF COVER, OR (C) ARE NOT REPRESENTED BY A FITTING OR SIZE SHOWN HEREON.
5. 'L' IS APPROXIMATELY EQUAL TO 'H' FOR SMALLER THRUST BLOCKS. 'L' IS GREATER THAN H FOR LARGER THRUST BLOCKS. 'H' SHALL NOT EXCEED TRENCH HEIGHT.
6. REBAR AT VALVES AND VERTICAL BENDS SHALL BE EPOXY COATED.

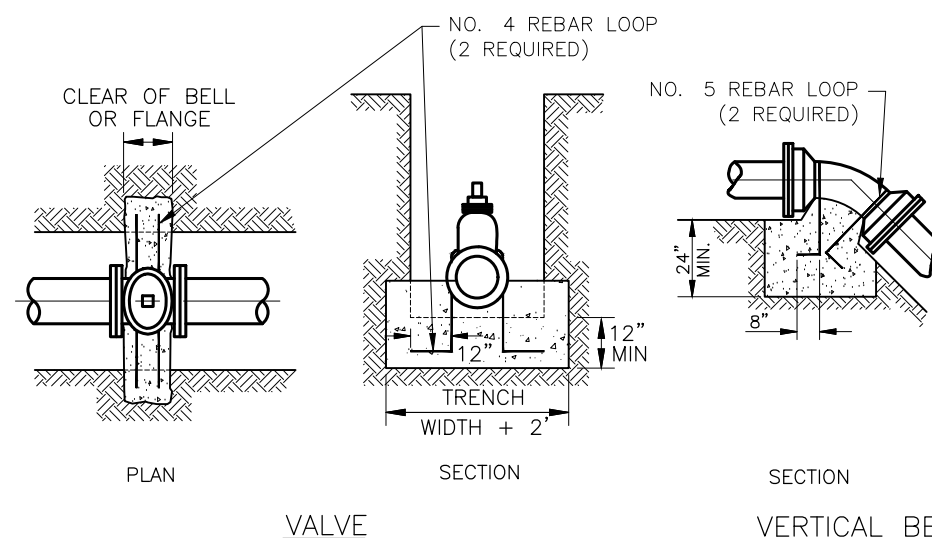

PIPE SIZE (IN)	CONCRETE VOLUME (CUBIC YARDS)		
	45°	22.5°	11.25°
4	0.7	0.4	0.2
6	1.6	0.8	0.4
8	2.8	1.5	0.7
10	4.4	2.2	1.1
12	6.4	3.2	1.6
16	11.4	5.6	2.8

THRUST BLOCK SIZES

Bearing Area (sq-ft) and Thrust Block Dimensions (in)

PIPE SIZE (inches)	DEAD END			TEE OR CROSS			90° BEND			45° BEND			22.5° BEND			11.25° BEND		
	Area (sq-ft)	L (in)	H (in)	Area (sq-ft)	L (in)	H (in)	Area (sq-ft)	L (in)	H (in)	Area (sq-ft)	L (in)	H (in)	Area (sq-ft)	L (in)	H (in)	Area (sq-ft)	L (in)	H (in)
4	2.0	17	17	2.0	17	17	2.9	21	21	1.9	17	17	1.0	12	12	0.4	8	8
6	4.3	25	25	4.3	25	25	6.0	30	30	4.3	25	25	2.2	18	18	1.0	12	12
8	7.4	36	30	7.4	36	30	10.5	42	36	7.6	37	30	3.9	24	24	1.9	17	17
10	12.1	42	42	12.1	42	42	17.1	59	42	10.3	42	36	5.5	30	27	3.1	22	22
12	17.2	52	48	17.2	52	48	24.3	73	48	17.2	52	48	8.7	42	30	4.3	26	24
16	26.7	72	54	26.7	72	54	37.8	101	54	30.6	82	54	15.6	54	42	7.8	38	30

STEEL CASING DIMENSION TABLE

<u>PIPE SIZE</u>	<u>MIN. CASING SIZE</u>	<u>MIN. WALL THICKNESS</u>
6"	16" I.D.	1/4"
8"	18" I.D.	1/4"
10"	21" I.D.	5/16"
12"	24" O.D.	5/16"
16"	30" O.D.	3/8"

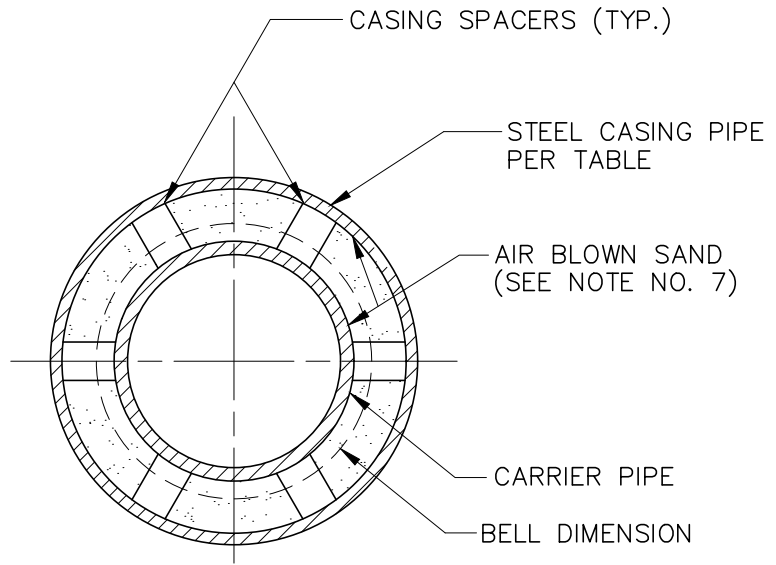

CROSS SECTION

NOTES:

1. CASING SHALL BE INSTALLED BY THE BORE, JACK AND/OR TUNNEL METHOD.
2. CARRIER PIPE SHALL BE AIR TESTED PRIOR TO FILLING CASING.
3. UPSTREAM AND DOWNSTREAM ELEVATIONS TO BE VERIFIED PRIOR TO FILLING CASING.
4. ALL CASING SECTIONS TO BE JOINED BY CONTINUOUS WELD.
5. CASING SHALL BE SEALED WITH AN END SEAL ON EACH END.
6. ALL PIPE JOINTS WITHIN THE CASING SHALL BE RESTRAINED.
7. UNLESS OTHERWISE NOTED ON THE PLANS, THE ANNULAR SPACE WITHIN THE CASING SHALL BE FILLED WITH AIR BLOWN SAND.

GENERAL NOTE

THE STATE WATER RESOURCES CONTROL BOARD (SWRCB) AND STATE OF CALIFORNIA REGULATIONS (TITLE 22, CHAPTER 16 SECTION 64572) SHALL BE FOLLOWED WHEN DESIGNING AND CONSTRUCTING NEW POTABLE WATER, RECYCLED WATER, AND SEWER MAINS. WHEN SWRCB AND DISTRICT STANDARDS CONFLICT, THE MOST STRINGENT REQUIREMENT SHALL APPLY UNLESS OTHERWISE APPROVED BY THE DISTRICT.

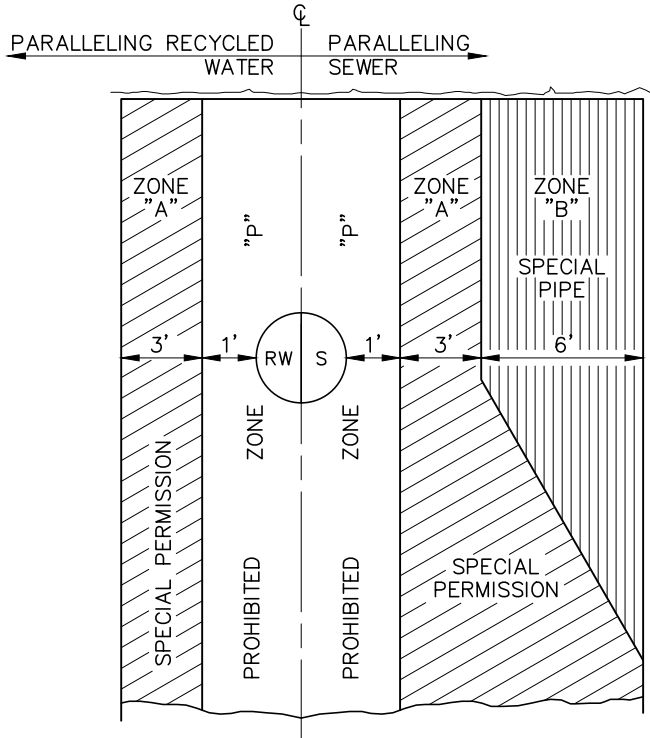

BASIC SEPARATION STANDARDS

1. PARALLEL CONSTRUCTION: THE HORIZONTAL DISTANCE BETWEEN PRESSURE POTABLE WATER AND THE FOLLOWING MAINS SHALL BE AT LEAST:
 - a) TERTIARY-TREATED RECYCLED WATER: 4'
 - b) SEWER: 10'
2. PERPENDICULAR CONSTRUCTION (CROSSING): PRESSURE POTABLE WATER MAINS SHALL BE AT LEAST ONE FOOT ABOVE SEWER AND RECYCLED WATER LINES WHERE THESE LINES MUST CROSS.

SPECIAL CONSTRUCTION REQUIRED FOR WATER

ZONE

- "A"** NO POTABLE WATER LINES PARALLEL TO RECYCLED WATER OR SEWER LINES SHALL BE PERMITTED IN THIS ZONE WITHOUT APPROVAL FROM COUNTY AND STATE BOARD'S DIVISION OF DRINKING WATER AND THE DISTRICT. IF APPROVED, ZONE 'B' PIPE MATERIALS ARE REQUIRED UNLESS OTHERWISE REQUIRED.
- "B"** THE POTABLE WATER MAIN SHALL BE CONSTRUCTED OF:
1. CLASS 200 PRESSURE RATED PLASTIC WATER PIPE (DR 14 PER AWWA C900) OR EQUIVALENT.
 2. DUCTILE IRON PIPE.
 3. HDPE PIPE WITH BUTT-FUSED JOINTS
 4. CEMENT-MORTAR LINED AND COATED 1/4" THICK STEEL PIPE WITH WELDED JOINTS.
- "C"** THE POTABLE WATER MAIN SHALL HAVE NO JOINTS IN ZONE "C" AND BE CONSTRUCTED OF:
1. DUCTILE IRON PIPE.
 2. HDPE PIPE WITH BUTT-FUSED JOINTS
 3. CEMENT-MORTAR LINED AND COATED 1/4" THICK STEEL PIPE WITH WELDED JOINTS.
- "D"** THE POTABLE WATER MAIN SHALL HAVE NO JOINTS WITHIN 8- FEET FROM EITHER SIDE OF THE RECYCLED OR SEWER LINE AND SHALL BE CONSTRUCTED OF:
1. CLASS 200 PRESSURE RATED PLASTIC WATER PIPE (DR 14 PER AWWA C900) OR EQUIVALENT.
 2. DUCTILE IRON PIPE.
 3. HDPE PIPE WITH BUTT-FUSED JOINTS
 4. CEMENT-MORTAR LINED AND COATED 1/4" THICK STEEL PIPE WITH WELDED JOINTS.
- "P"** NO WATER MAIN SHALL BE CONSTRUCTED PER SECTION 64630 (2) CALIFORNIA ADMINISTRATIVE CODE, TITLE 22.

POTABLE WATER MAIN PARALLEL TO SEWER/RECYCLED WATER MAINS

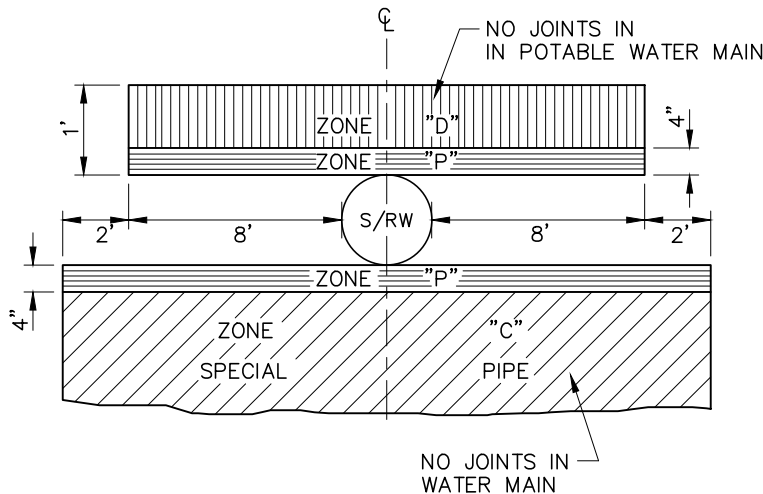

POTABLE WATER MAIN CROSSING SEWER/RECYCLED WATER MAINS

S = SEWER MAIN
RW = RECYCLED WATER MAIN

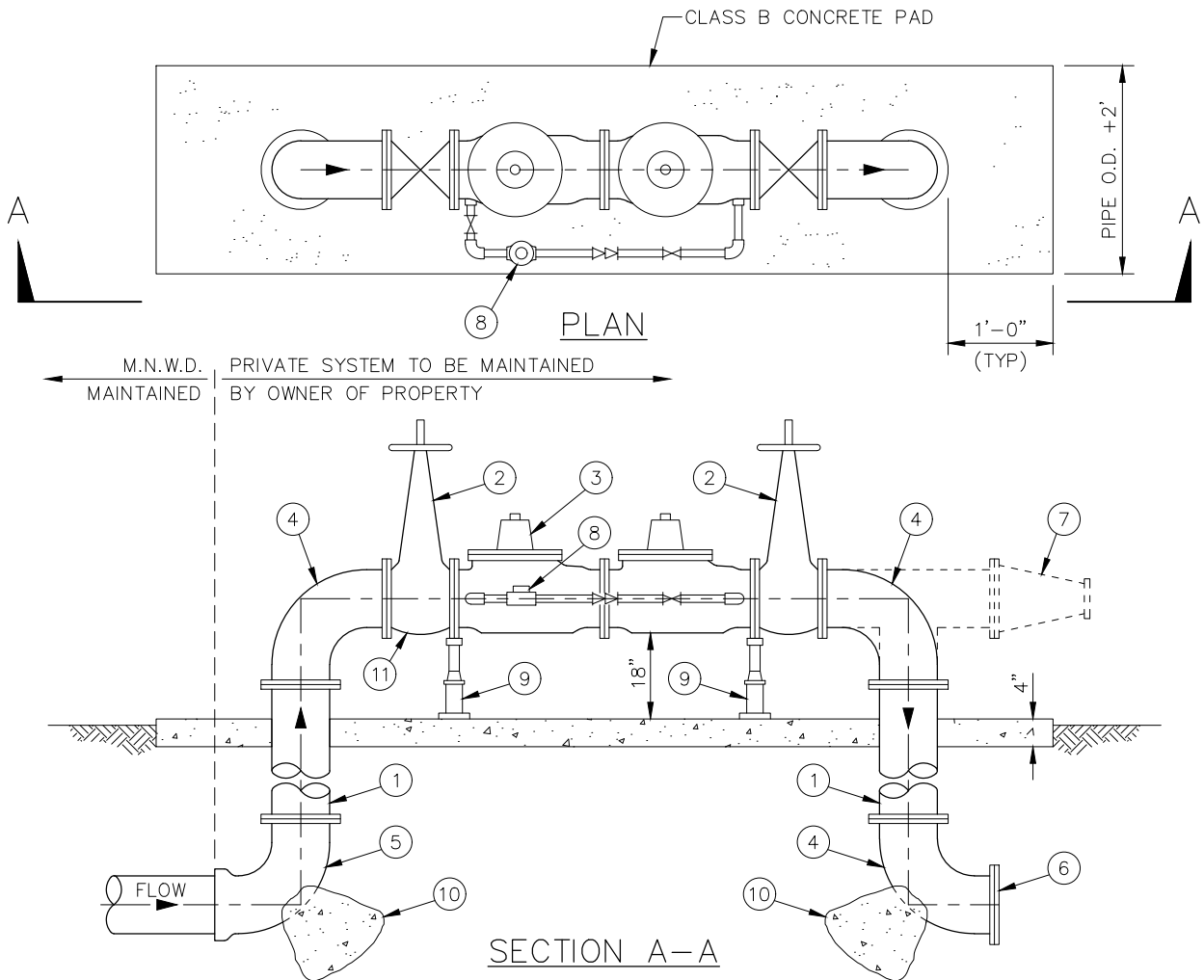

CONSTRUCTION ITEMS

- ① DUCTILE IRON FLANGED SPOOL, CLASS 53
- ② RESILIENT WEDGE GATE VALVE OS & Y
- ③ STATE WATER RESOURCE CONTROL BOARD DOUBLE CHECK DETECTOR ASSEMBLY, OR AS OTHERWISE REQUIRED BY THE DISTRICT.
- ④ DUCTILE IRON FLANGED 90° ELBOW
- ⑤ DUCTILE IRON PUSH-ON x FLANGE 90° ELBOW
- ⑥ BLIND FLANGE
- ⑦ OPTIONAL TEE, AND 2 1/2 SIAMESE FIRE DEPT. CONNECTION
- ⑧ DISTRICT APPROVED 3/4-INCH BYPASS METER (MNWD MAINTAINED)
- ⑨ ADJUSTABLE PIPE SUPPORT, GRINNELL NO. 264 OR APPROVED EQUAL
- ⑩ THRUST BLOCK PER STD. DWG. W-12
- ⑪ NOTIFY DISTRICT INSPECTOR AT LEAST 72 HOURS PRIOR TO ANY WORK THAT IS TO OCCUR UPSTREAM OF THE FIRST ISOLATION VALVE. (NOT SHOWN ON DRAWING)

NOTES

1. ALL UNITS MUST BE ON THE LATEST APPROVED LIST OF BACKFLOW PREVENTION DEVICES FROM THE CALIFORNIA STATE WATER RESOURCES CONTROL BOARD.
2. INSTALLATION SHALL COMPLY WITH THE LATEST PLUMBING CODES AND APPLICABLE LOCAL AGENCY REQUIREMENTS.
3. UPON COMPLETION OF THE INSTALLATION OF THE DEVICE, A TEST SHALL BE PERFORMED AND A CERTIFICATE OF ADEQUACY AND OPERATIONAL COMPLIANCE SHALL BE FURNISHED TO MNWD.
4. FIRE SERVICE DETECTOR CHECK AND BACKFLOW PREVENTION ASSEMBLY SHALL BE INSTALLED IN A PUBLIC RIGHT-OF-WAY OR AN EASEMENT DEDICATED TO THE DISTRICT.
5. ALL ABOVE GROUND PIPING SHALL BE PRIMED AND PAINTED PER SECTION 09900.
6. MAINTENANCE OF THE BACKFLOW DEVICE, PIPING, FITTINGS, CONNECTIONS AND VALVES SHALL BE THE RESPONSIBILITY OF THE CUSTOMER INCLUDING POINT OF CONNECTION AT CHANGE OF OWNERSHIP.

MOULTON NIGUEL WATER DISTRICT
 ABOVE GROUND PRIVATE FIRE SERVICE

W-15
 JANUARY 2019

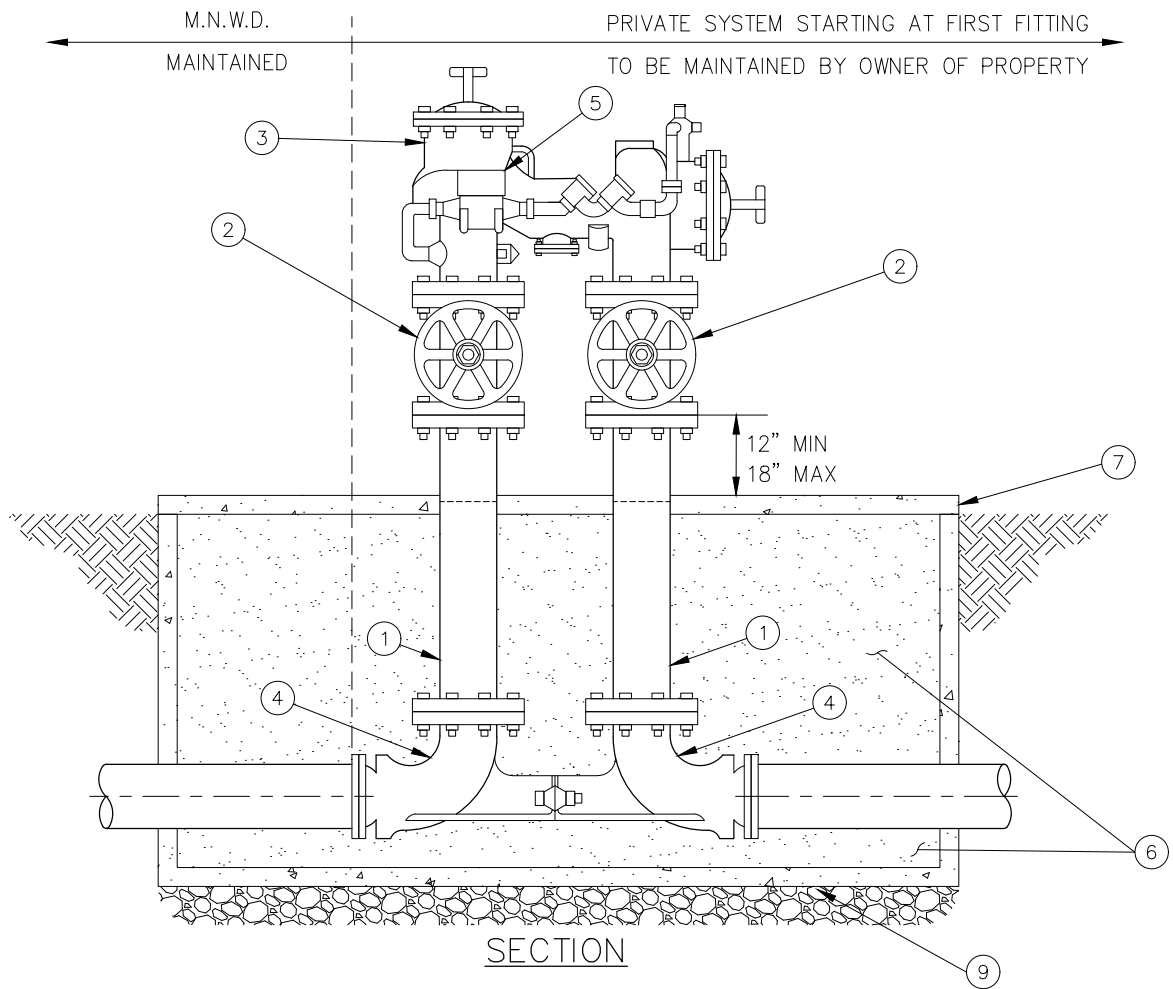

CONSTRUCTION ITEMS

- | | |
|--|--|
| <ul style="list-style-type: none"> ① DUCTILE IRON FLANGED SPOOL, 350 PSI RATING ② RESILIENT WEDGE GATE VALVE ③ STATE HEALTH DEPT. DOUBLE CHECK DETECTOR ASSEMBLY, OR AS OTHERWISE REQUIRED BY THE DISTRICT. ④ DUCTILE IRON FLANGED ELBOW WITH VALVE SETTER, 350 PSI RATING ⑤ DISTRICT APPROVED BYPASS METER (MNWD MAINTAINED) | <ul style="list-style-type: none"> ⑥ "0" SACK SLURRY TO TOP OF VAULT ⑦ 4" CONCRETE PAD ⑧ NOTIFY DISTRICT INSPECTOR AT LEAST 72 HOURS PRIOR TO ANY WORK THAT IS TO OCCUR UPSTREAM OF THE FIRST ISOLATION VALVE. (NOT SHOWN ON DRAWING) ⑨ CORE FOUR (4) 1" DIAMETER HOLES THROUGH THE BOTTOM OF THE EXISTING CONCRETE VAULT FLOOR. |
|--|--|

NOTES

1. ALL UNITS MUST BE ON THE LATEST APPROVED LIST OF BACKFLOW PREVENTION DEVICES FROM THE U.S.C. / F.C.C.C. & H.R. INSTITUTE AND COMPLY WITH THE CALIFORNIA STATE WATER RESOURCES CONTROL BOARD.
2. INSTALLATION SHALL COMPLY WITH THE LATEST PLUMBING CODES AND APPLICABLE LOCAL AGENCY REQUIREMENTS.
3. UPON COMPLETION OF THE INSTALLATION OF THE DEVICE, A TEST SHALL BE PERFORMED AND A CERTIFICATE OF ADEQUACY AND OPERATIONAL COMPLIANCE SHALL BE FURNISHED TO M.N.W.D.
4. FIRE SERVICE DETECTOR CHECK AND BACKFLOW PREVENTION ASSEMBLY SHALL BE INSTALLED IN A PUBLIC RIGHT-OF-WAY OR AN EASEMENT DEDICATED TO THE DISTRICT.
5. ALL ABOVE GROUND PIPING SHALL BE PRIMED AND PAINTED PER SECTION 09900.
6. MAINTENANCE OF THE BACKFLOW DEVICE, PIPING, FITTINGS, CONNECTIONS AND VALVES SHALL BE THE RESPONSIBILITY OF THE CUSTOMER INCLUDING POINT OF CONNECTION AT CHANGE OF OWNERSHIP.
7. INSTALL CONCRETE SLAB UNDER ASSEMBLY, LENGTH = ASSEMBLY LENGTH +12" EACH SIDE, WIDTH = PIPE DIAMETER +12" EACH SIDE, THICKNESS = 4".
8. WRAP & GREASE BURIED PORTIONS OF PIPE AND APPURTENANCES IN CONCRETE VAULT.

NOTES

1. ATTACH BLUE POTABLE WATER IDENTIFICATION TAGS AS DIRECTED ON POTABLE SYSTEMS USING METALLIC WIRE (NO PLASTIC ZIPS).
2. ATTACH GREEN POTABLE IRRIGATION IDENTIFICATION TAGS AS DIRECTED ON POTABLE IRRIGATION SYSTEMS USING METALLIC WIRE (NO PLASTIC ZIPS).
3. ALL BACKFLOW PREVENTION DEVICES FOR METER PROTECTION SHALL BE INSTALLED DIRECTLY OUTSIDE OF THE WATER METER BOX.
4. ALL BACKFLOW PREVENTION DEVICES MUST BE ON THE LATEST APPROVED LIST OF BACKFLOW PREVENTION DEVICES FROM THE U.S.C. / F.C.C.C. & H.R. INSTITUTE AND COMPLY WITH THE CALIFORNIA STATE WATER RESOURCES CONTROL BOARD.

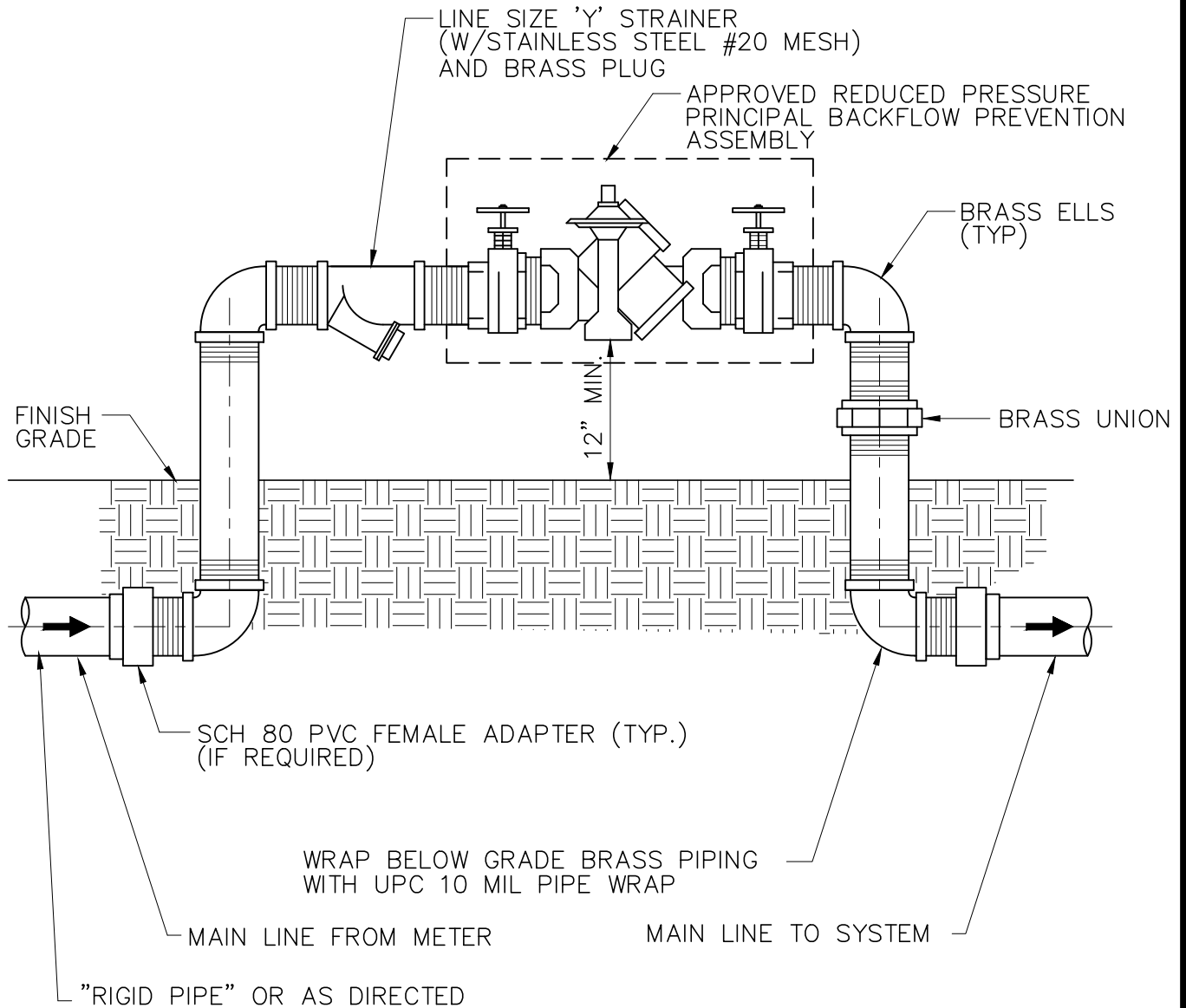

CONSTRUCTION ITEMS

- ① N.R.S. VALVE
- ② TEST COCK
- ③ APPROVED REDUCED PRESSURE PRINCIPAL BACKFLOW PREVENTION ASSEMBLY
- ④ DIFFERENTIAL PRESSURE RELIEF VALVE
- ⑤ ADJUSTABLE PIPE SUPPORT
- ⑥ THRUST BLOCK PER STD. DWG. W-12

NOTES

- 1. ALL BACKFLOW PREVENTION ASSEMBLIES MUST BE ON THE LATEST APPROVED LIST OF BACKFLOW PREVENTION DEVICES FROM THE CALIFORNIA STATE WATER RESOURCES CONTROL BOARD.
- 2. BACKFLOW ASSEMBLY TO BE INSTALLED DIRECTLY UPSTREAM OF WATER METER

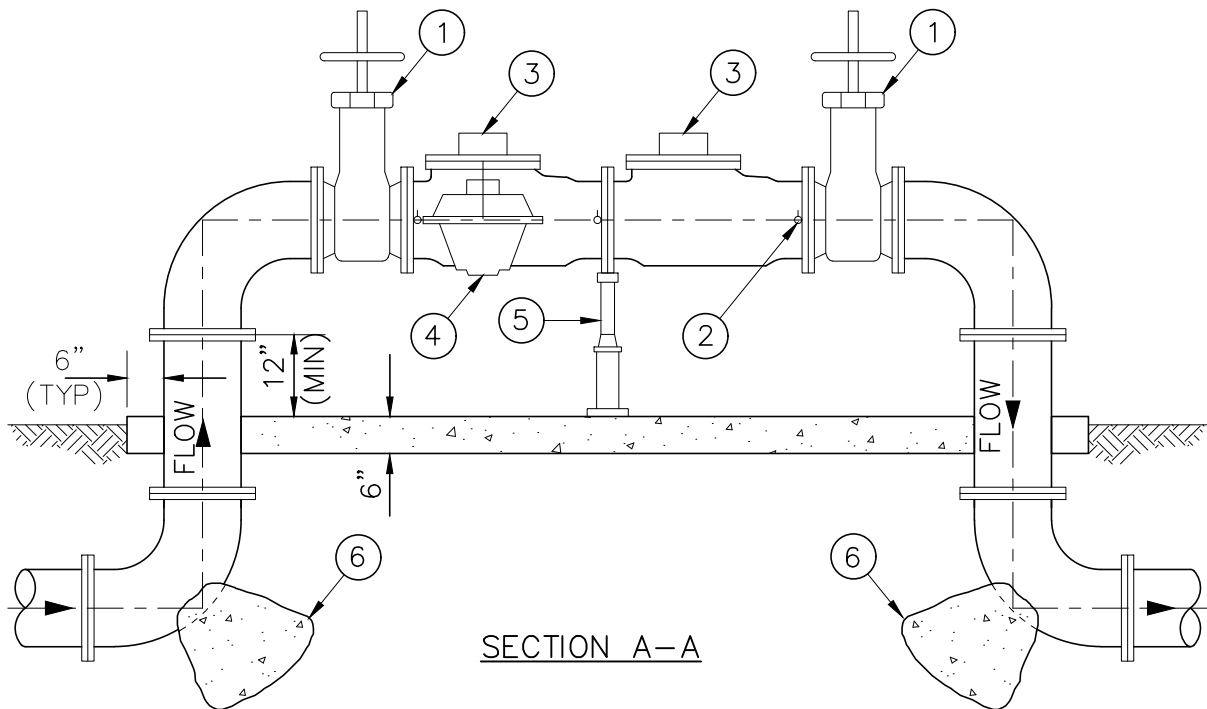
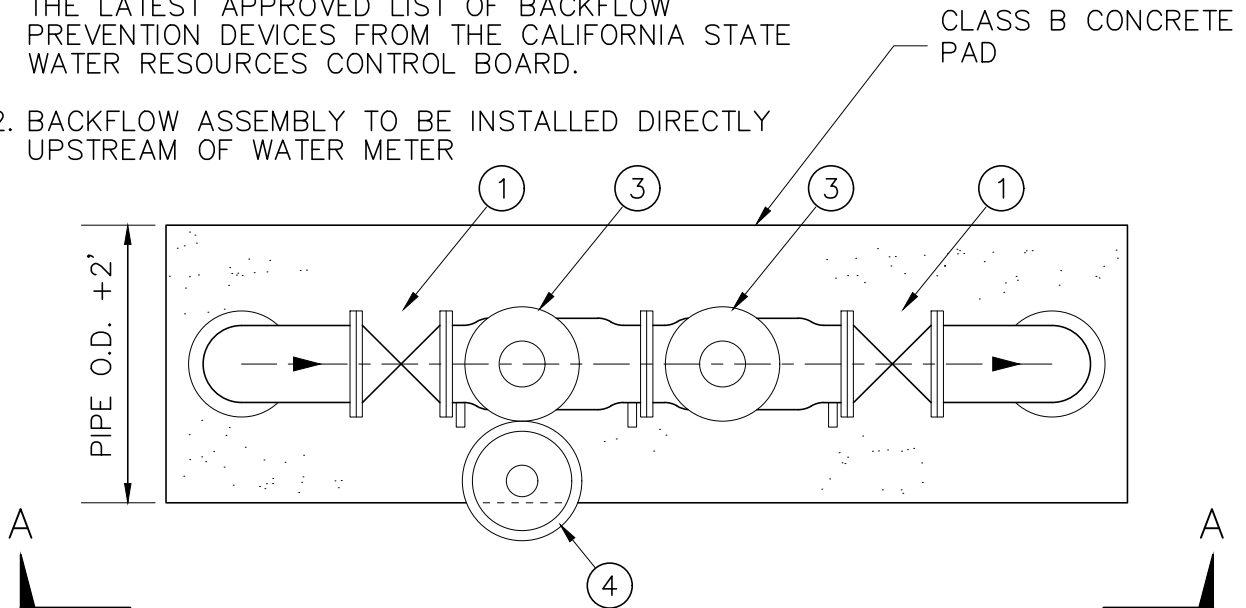

MOULTON NIGUEL WATER DISTRICT
 BACKFLOW PREVENTION DEVICE
 3" AND LARGER

W-18
 JANUARY 2019

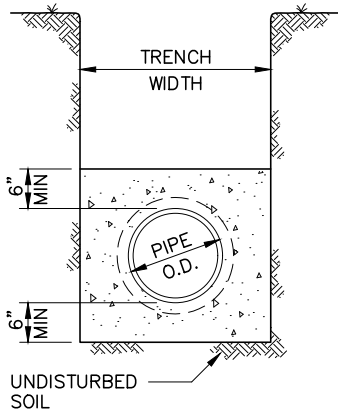

TYPE "A"

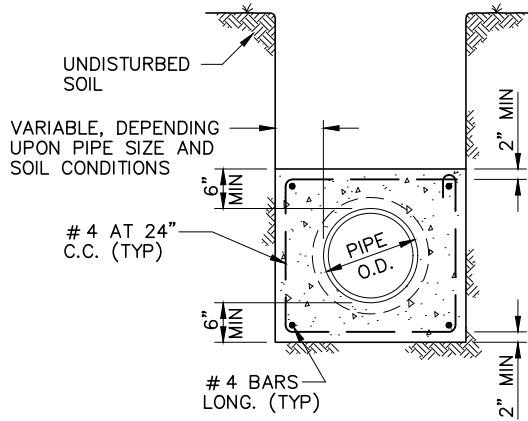

TYPE "B"

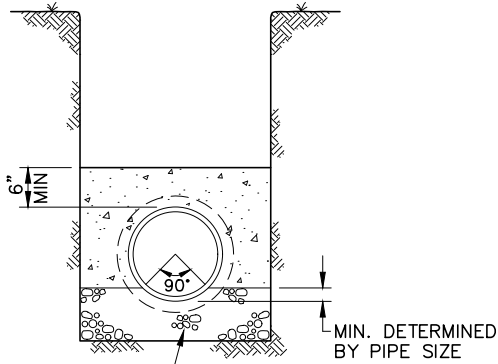

BEDDING, SEE STD. DWG. S-8

TYPE "C"

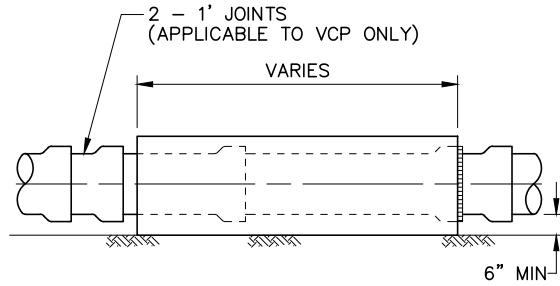

SECTION

NOTES:

- ENCASEMENT TO BE PLACED AGAINST UNDISTURBED NATURAL GROUND OR FILL COMPACTED TO 90% RELATIVE COMPACTION.
- USE NO. 4 STEEL REINFORCING BARS.
- TYPE OF CONCRETE ENCASEMENT TO BE USED WILL BE SHOWN ON PLANS OR AS SPECIFIED BY INSPECTOR TO MEET UNFORESEEN FIELD CONDITIONS.
- WHERE SLOPE TRENCHES ARE USED, WALLS WILL NOT BEGIN TO SLOPE CLOSER THAN 12" FROM THE TOP OF THE PIPE.
- ENCASEMENT CONCRETE TO BE CLASS "B".
- CONTINUE D.I.P. POLY BAG ENCASEMENT THROUGH CONCRETE.

CONCRETE ENCASEMENT

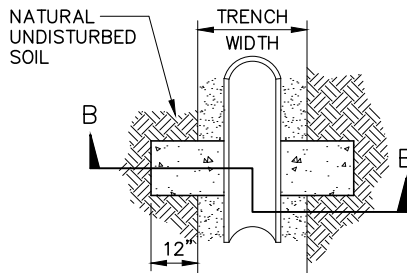
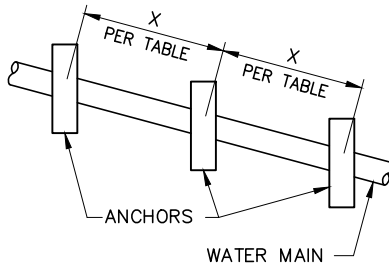

SECTION A-A

NOTES:

- PIPE ANCHORS REQUIRED ON ALL SLOPES OF 20% OR GREATER.
- ANCHOR SHALL EXTEND 12" INTO NATURAL UNDISTURBED SOIL.
- CONCRETE SHALL BE CLASS "B".
- ANCHORS FOR TRAPEZOIDAL TRENCH SECTIONS WILL CONFORM TO TRENCH CROSS SECTION AND EXTEND 12" INTO UNDISTURBED SOIL.
- DO NOT EXTEND D.I.P. POLY BAG THRU ANCHORS - SEAL BAG TO PIPE ON EACH SIDE OF EACH ANCHOR.

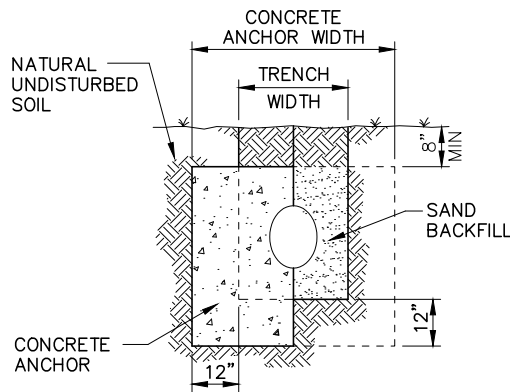
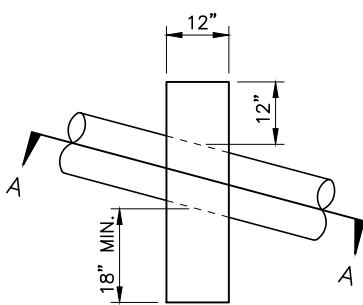

SECTION B-B

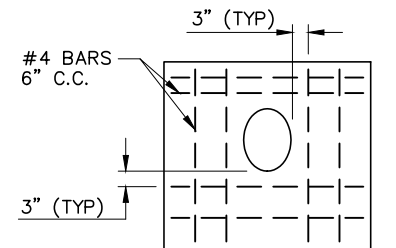

REINFORCING STEEL PATTERN

SLOPE ANCHORS

TABLE

PIPE SLOPE	X DISTANCE
20% TO 35%	36'
35% TO 50%	24'
> 50%	16'

MOULTON NIGUEL WATER DISTRICT

CONCRETE ENCASEMENT AND SLOPE ANCHORS

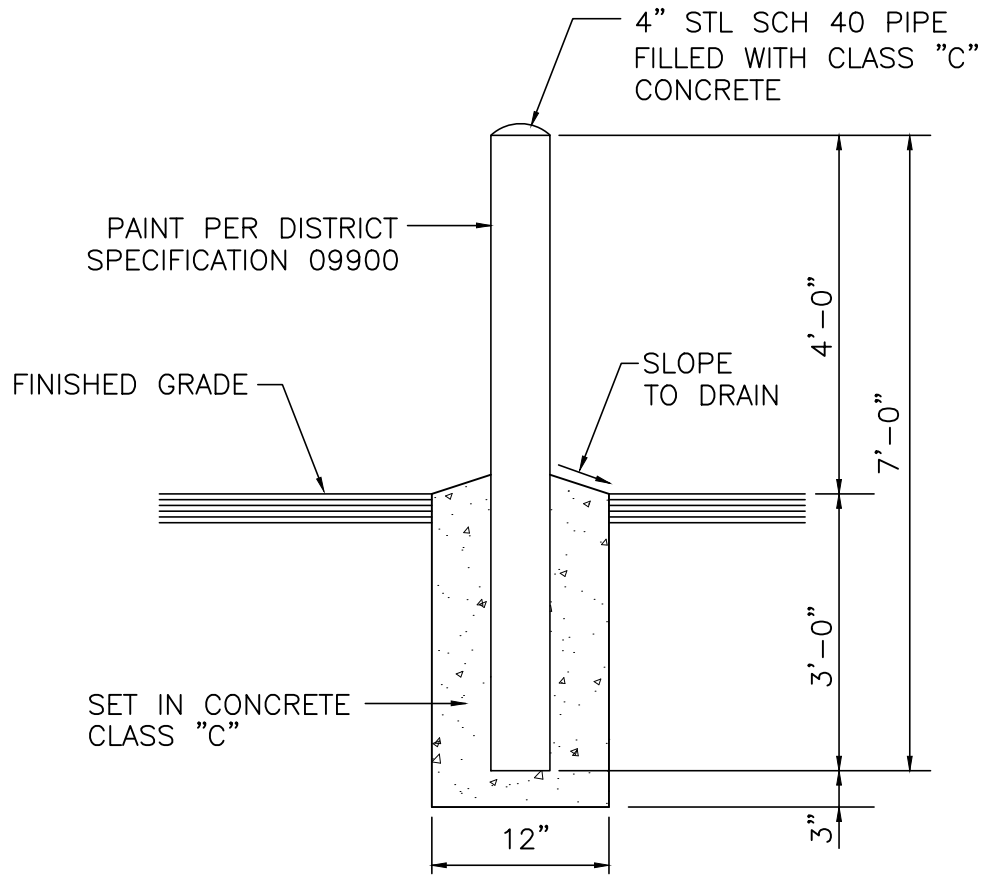

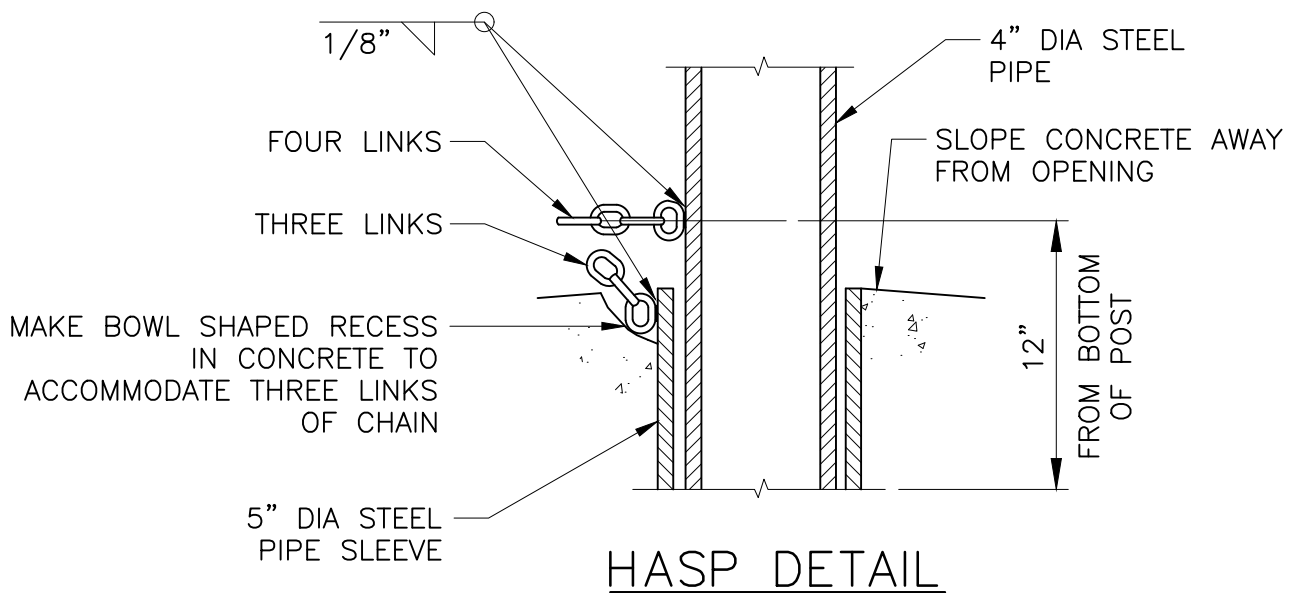
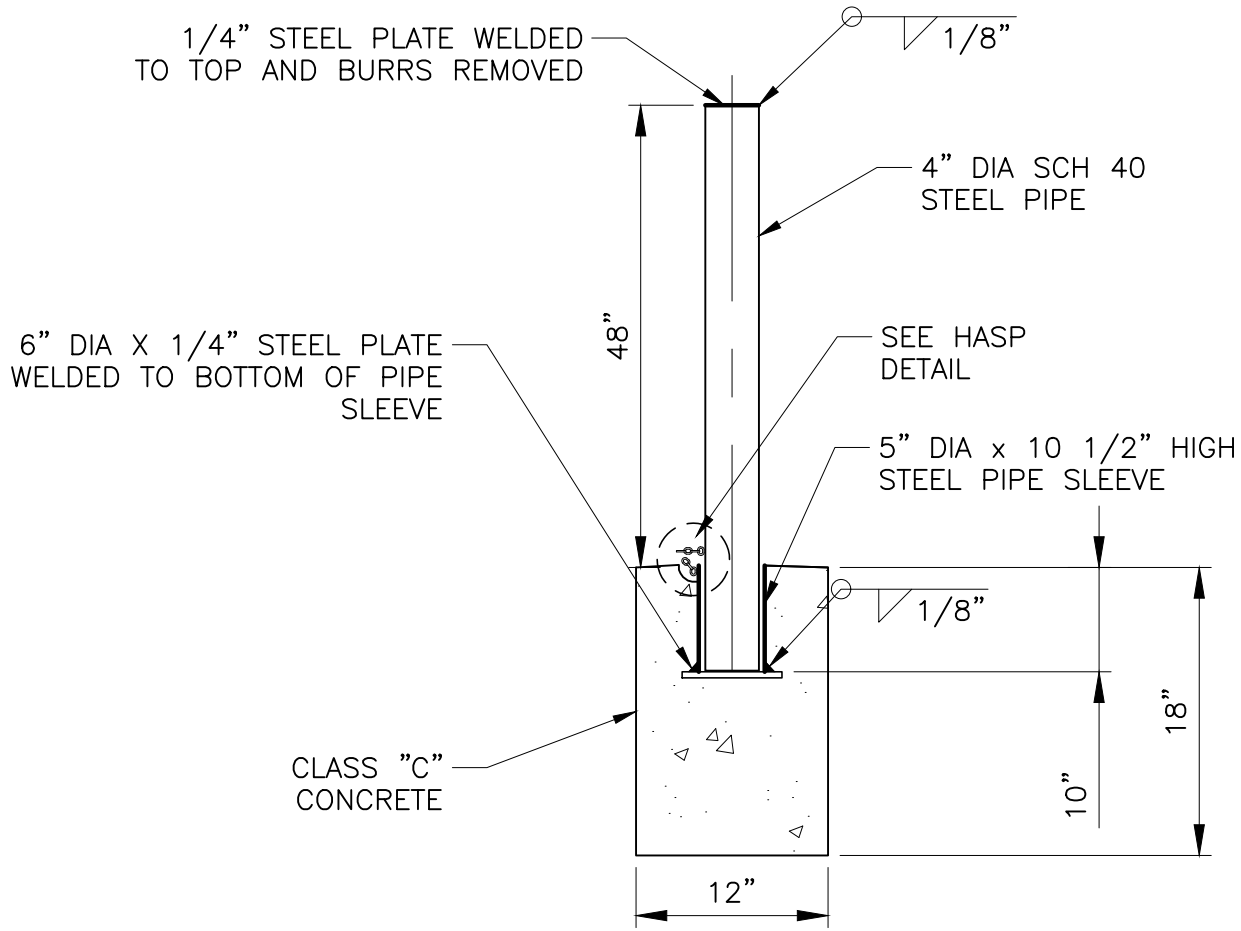

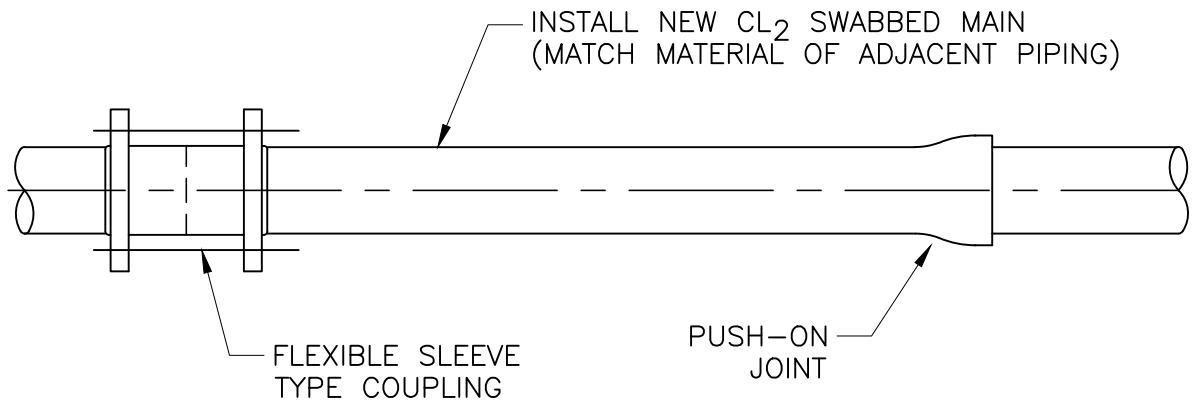
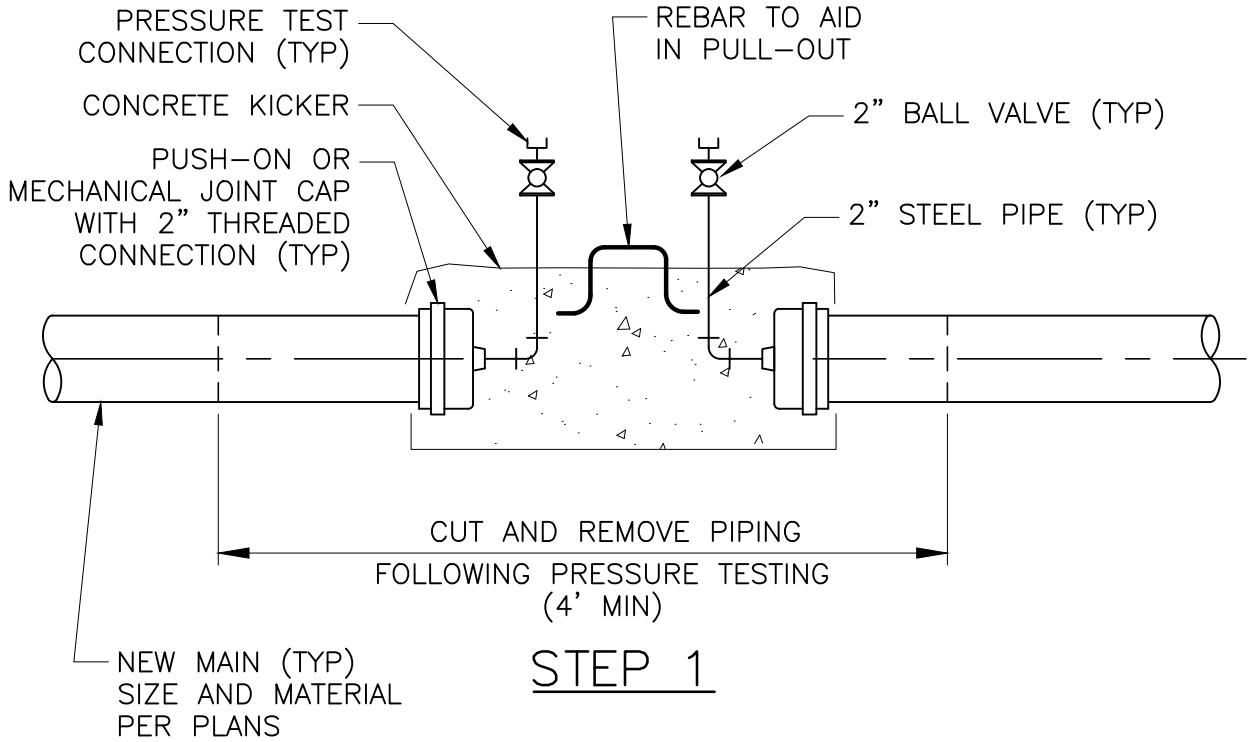

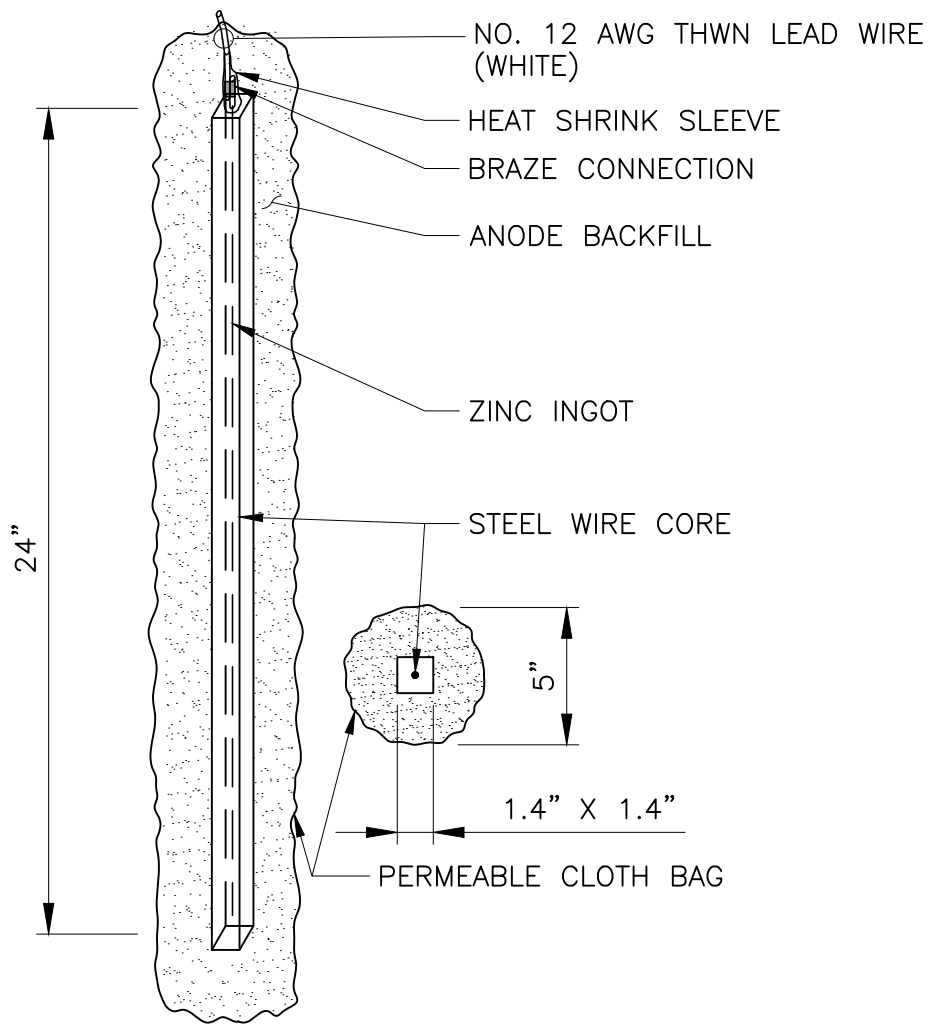

NOTE :

ANODE SOAKING REQUIREMENTS:
 PLACE ANODE IN HOLE OR TRENCH. ADD 5 GALLONS OF WATER AND ALLOW TO SOAK FOR 30 MIN. BACKFILL TO TOP OF ANODE. ADD AN ADDITIONAL 5 GALLONS OF WATER TO COMPLETELY SATURATE THE SOIL SURROUNDING ANODE. LET SOAK FOR 15 MIN. PRIOR TO BACKFILLING.

MOULTON NIGUEL WATER DISTRICT

ZINC ANODE FOR SERVICES
 AND AIR-VACS

W-23
 JANUARY 2019

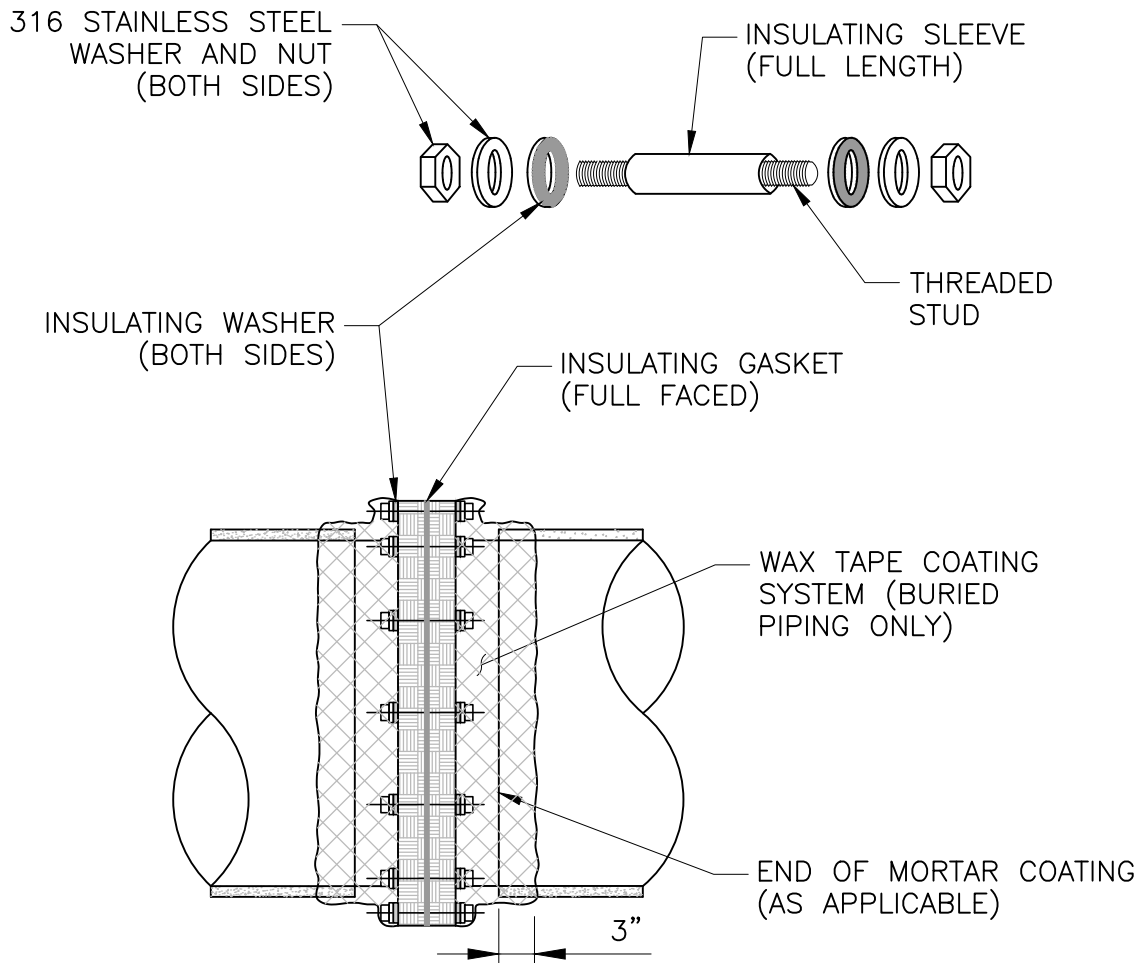

NOTES :

1. CARE SHALL BE TAKEN WHEN BACKFILLING TRENCH TO PREVENT DAMAGE TO WAX TAPE SYSTEM.
2. USE HALF-WIDTH SLEEVES AT THREADED FLANGE BOLTS (I.E. AT BUTTERFLY VALVE BONNET)
3. DO NOT PAINT OUTER SURFACE OF FLANGE WITH METALLIC PIGMENTED OR CONDUCTIVE PAINTS.

MOULTON NIGUEL WATER DISTRICT

ABOVE GROUND AND BURIED
INSULATING FLANGE

W-24

JANUARY 2019

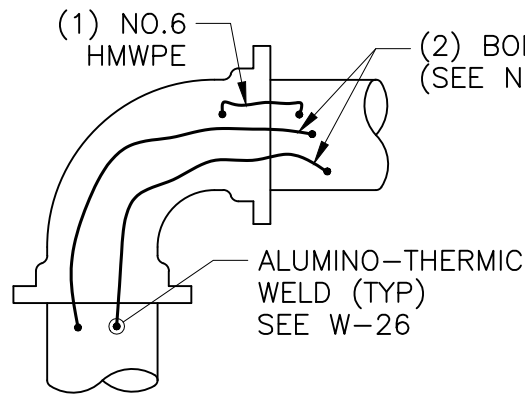

FITTING

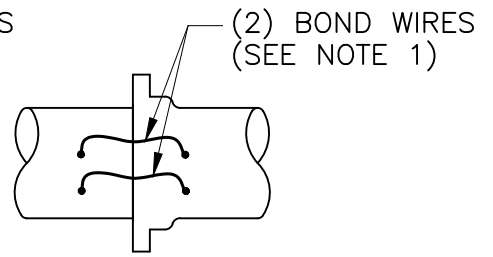

MECHANICAL
OR PUSH-ON
JOINT

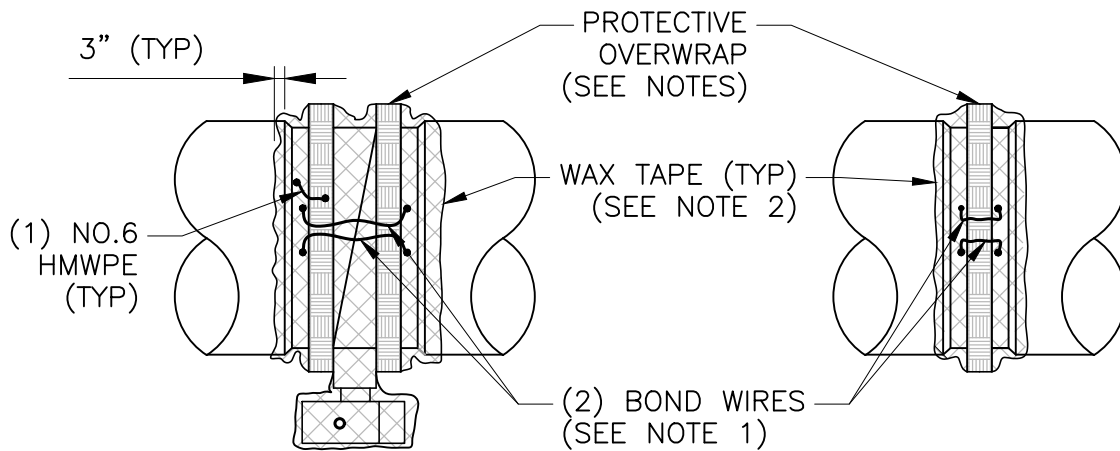

VALVE

FLANGE

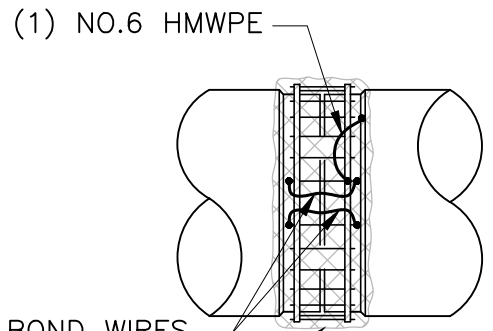

COUPLING

NOTES :

1. BOND WIRE SIZE:

PIPE DIA	SIZE
<14"	NO. 6 AWG HMWPE
<20"	NO. 4 AWG HMWPE
>20"	NO. 2 AWG HMWPE

2. INSTALL BOND WIRES BEFORE WAX TAPE.

STEP 1

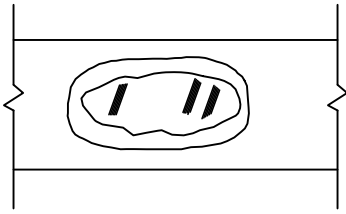

CHIP OUT MORTAR (CML&C) AND/OR FILE SURFACE TO BRIGHT METAL AND CLEAN

STEP 2

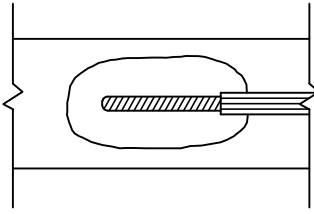

STRIP INSULATION FROM WIRE

STEP 3

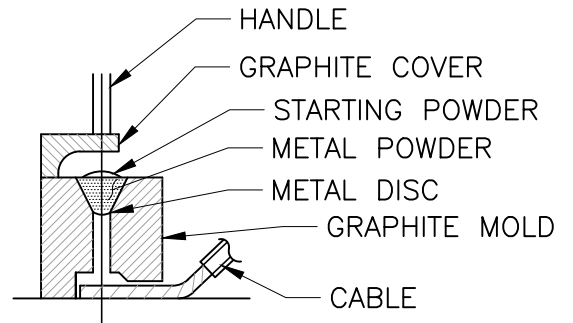

HOLD WELDER FIRMLY WITH OPENING AWAY FROM OPERATION AND IGNITE STARTING POWDER

STEP 4

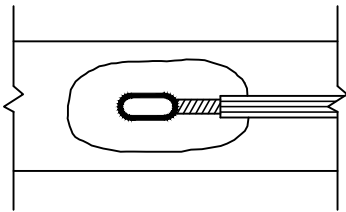

REMOVE SLAG FROM CONNECTION

STEP 5

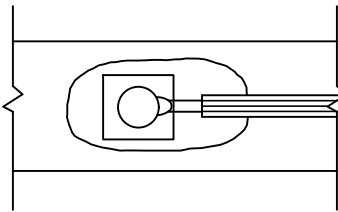

APPLY 2 COATS OF PRIMER AND COVER CONNECTION WITH A PREFORMED WELD CAP

STEP 6

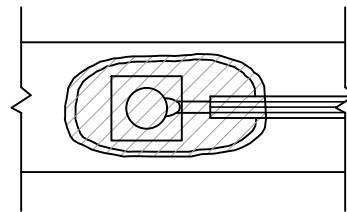

COAT AREA WITH BITUMEN. PATCH MORTAR. SEE NOTE 3

NOTES :

1. WELDER SHOWN IS FOR HORIZONTAL SURFACES. FOR VERTICAL SURFACES SIDE WELDER IS REQUIRED.
2. ALL WIRE WELDS SHALL BE 3 INCHES APART, MINIMUM.
3. APPLY GENEROUS COAT OF BITUMINOUS MASTIC OVER WELD CAP AND EXPOSED METAL AREA UP TO EDGE OF MORTAR (CML&C) OR 3" BEYOND WELD CAP (DIP).
4. PATCH MORTAR COATING WITH QUICK SETTING MORTAR (CML&C).

GENERAL OFF-SITE RECYCLED WATER NOTES

1. ALL MNWD GENERAL CONSTRUCTION NOTES (PER MNWD STANDARD DRAWING G-GN) AND ALL MNWD GENERAL POTABLE WATER NOTES (PER MNWD STANDARD DRAWING W-GN) SHALL APPLY.
2. ALL CONSTANT PRESSURE RECYCLED AND POTABLE WATER MAIN LINE PIPING INSTALLED ON THIS PROJECT SHALL BE IDENTIFIED IN ACCORDANCE WITH THE DISTRICT'S SPECIFICATIONS.
 - A. WARNING TAPES SHALL BE USED ON ALL CONSTANT PRESSURE MAIN LINE PIPING CARRYING RECYCLED OR POTABLE WATER.
 - B. WARNING TAPES SHALL BE A MINIMUM OF 6 INCHES WIDE FOR 6-INCH AND SMALLER PIPE AND 12 INCHES WIDE FOR 8-INCH AND LARGER PIPE. THE TAPE SHALL RUN CONTINUOUSLY FOR THE ENTIRE LENGTH OF ALL CONSTANT PRESSURE MAIN LINE PIPING, AND SHALL BE LOCATED 12 INCHES ABOVE THE TOP OF THE PIPE.
 - C. WARNING TAPE FOR THE CONSTANT PRESSURE RECYCLED WATER PIPING SHALL BE PURPLE IN COLOR WITH THE WORDS "CAUTION: RECYCLED WATER-LINE BURIED BELOW" IMPRINTED IN MINIMUM 1/2-INCH-HIGH LETTERS BLACK IN COLOR. IMPRINTING SHALL BE CONTINUOUS AND PERMANENT.
 - D. RECYCLED WATER DISTRIBUTION/TRANSMISSION MAINS SHALL BE PURPLE COLORED C900 PVC. DUCTILE IRON PIPE (DIP) MAY BE USED ONLY WITH SPECIAL PERMISSION FROM THE DISTRICT. IF DIP IS APPROVED, IT SHALL BE ENCASED WITHIN A PURPLE POLYETHYLENE SLEEVE.
 - E. ALTERNATELY TRANSMISSION/ DISTRIBUTION PIPING IN THE RECYCLED WATER SYSTEM, INCLUDING SERVICE LINES, VALVES, AND OTHER APPURTENANCES CAN BE COLORED PURPLE, PANTONE 522C, AND EMBOSSED OR BE INTEGRALLY STAMPED/MARKED CAUTION: RECYCLED WATER - DO NOT DRINK, OR BE INSTALLED WITH OR A PURPLE POLYETHYLENE VINYL WRAP, COLOR TO BE PANTONE 512C.
 - F. ALL SERVICE LINES SHALL BE ENCASED WITHIN A PURPLE COLORED POLYETHYLENE SLEEVE.
3. NEW RECYCLED WATER PIPE SHALL BE INSTALLED WITH A MINIMUM COVER OF 48" BELOW FINISHED SURFACE OR AS SHOWN ON PLANS (WHICHEVER IS GREATER).
4. RECYCLED WATER MAINS SHALL BE INSTALLED AFTER THE INSTALLATION OF CURB AND GUTTER AT SIX FEET OFF OF CURB FACE ON THE OPPOSITE SIDE OF THE STREET OF THE POTABLE WATER MAINS, UNLESS SHOWN OTHERWISE ON PLANS, OR AS STAKED BY THE APPLICANT'S SURVEYOR AT A MINIMUM 50-FOOT STATIONING IF NOT WITHIN A ROADWAY.
5. ALL VALVE COVERS ON OFF-SITE RECYCLED WATER FACILITIES SHALL BE CIRCULAR IN SHAPE WITH THE WORDS "RECYCLED" CAST THEREON, CONSTRUCTED AND MARKED PER THE MNWD STANDARD DRAWING W-8.
6. RECYCLED WATER MAINS SHALL NOT BE REQUIRED TO PASS DISINFECTION OR BACTERIOLOGICAL TESTS. PRESSURE AND LEAKAGE TEST PER SECTION 15042 OF THE STANDARD SPECIFICATIONS OF THE MOULTON NIGUEL WATER DISTRICT IS STILL REQUIRED, PRIOR TO ACCEPTANCE.
7. RECYCLED WATER SHALL BE USED TO FILL AND PRESSURE TEST RECYCLED WATER MAIN. ALL FLUSHING WATER SHALL BE CONVEYED TO SEWER MANHOLE. AN AIR GAP WILL BE REQUIRED. THIS SHALL BE CONDUCTED IN THE PRESENCE OF THE DISTRICT INSPECTOR.
8. CURBS SHALL BE INSCRIBED WITH A 2-INCH HIGH "RW" INDICATING LOCATIONS OF ALL RECYCLED WATER SERVICES.

MOULTON NIGUEL WATER DISTRICT

GENERAL OFF-SITE RECYCLED WATER NOTES

RW-GN
JANUARY 2019

GENERAL NOTE

THE STATE WATER RESOURCES CONTROL BOARD (SWRCB) AND STATE OF CALIFORNIA REGULATIONS (TITLE 22, CHAPTER 16 SECTION 64572) SHALL BE FOLLOWED WHEN DESIGNING AND CONSTRUCTING NEW POTABLE WATER, RECYCLED WATER, AND SEWER MAINS. WHEN SWRCB AND DISTRICT STANDARDS CONFLICT, THE MOST STRINGENT REQUIREMENT SHALL APPLY UNLESS OTHERWISE APPROVED BY THE DISTRICT.

BASIC SEPARATION STANDARDS

1. PARALLEL CONSTRUCTION: THE HORIZONTAL DISTANCE BETWEEN PRESSURE RECYCLED WATER AND THE FOLLOWING MAINS SHALL BE AT LEAST:
 - a) POTABLE WATER: 4'
 - b) SEWER: 10'
2. PERPENDICULAR CONSTRUCTION (CROSSING): PRESSURE POTABLE WATER MAINS SHALL BE AT LEAST ONE FOOT ABOVE RECYCLED WATER AND SEWER LINES WHERE THESE LINES MUST CROSS.

SPECIAL CONSTRUCTION REQUIRED FOR RECYCLED WATER

ZONE

"A" NO RECYCLED WATER LINES PARALLEL TO POTABLE OR SEWER LINES SHALL BE PERMITTED IN THIS ZONE WITHOUT APPROVAL FROM COUNTY AND STATE BOARD'S DIVISION OF DRINKING WATER AND THE DISTRICT. IF APPROVED, ZONE 'B' PIPE MATERIALS ARE REQUIRED UNLESS OTHERWISE REQUIRED.

"B" RECYCLED WATER MAINS SHALL BE CONSTRUCTED OF:

1. CLASS 200 PRESSURE RATED PLASTIC WATER PIPE (DR 14 PER AWWA C900) OR EQUIVALENT.
2. DUCTILE IRON PIPE.
3. HDPE PIPE WITH BUTT-FUSED JOINTS
4. CEMENT-MORTAR LINED AND COATED 1/4" THICK STEEL PIPE WITH WELDED JOINTS.

"C" RECYCLED WATER MAINS SHALL BE CONSTRUCTED OF:

1. DUCTILE IRON PIPE.
2. HDPE PIPE WITH BUTT-FUSED JOINTS
3. CEMENT-MORTAR LINED AND COATED 1/4" THICK STEEL PIPE WITH WELDED JOINTS.

"D" RECYCLED WATER MAINS SHALL BE CONSTRUCTED OF:

1. CLASS 200 PRESSURE RATED PLASTIC WATER PIPE (DR 14 PER AWWA C900) OR EQUIVALENT.
2. DUCTILE IRON PIPE.
3. HDPE PIPE WITH BUTT-FUSED JOINTS
4. CEMENT-MORTAR LINED AND COATED 1/4" THICK STEEL PIPE WITH WELDED JOINTS.

"P" NO RECYCLED WATER MAIN SHALL BE CONSTRUCTED PER SECTION 64630 (2) CALIFORNIA ADMINISTRATIVE CODE, TITLE 22.

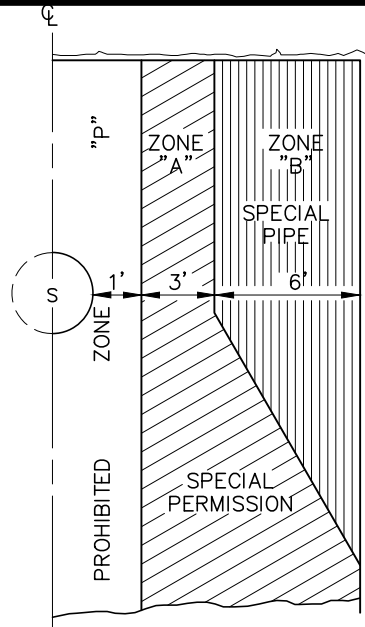

RECYCLED WATER MAIN PARALLEL TO SEWER MAINS

S = SEWER MAIN
PW = POTABLE WATER MAIN

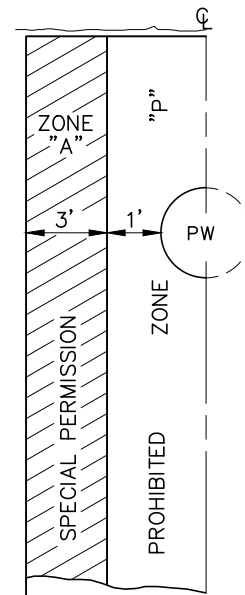

RECYCLED WATER MAIN PARALLEL TO POTABLE WATER MAINS

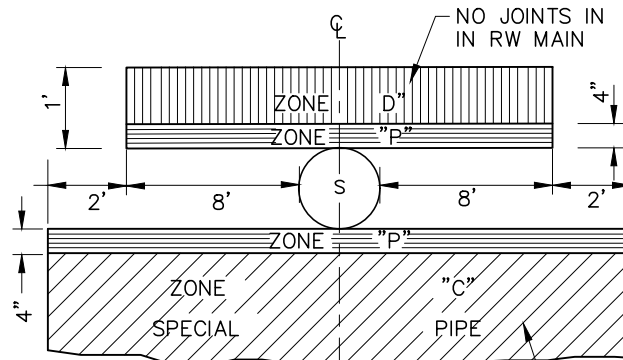

RECYCLED WATER MAIN CROSSING SEWER MAINS

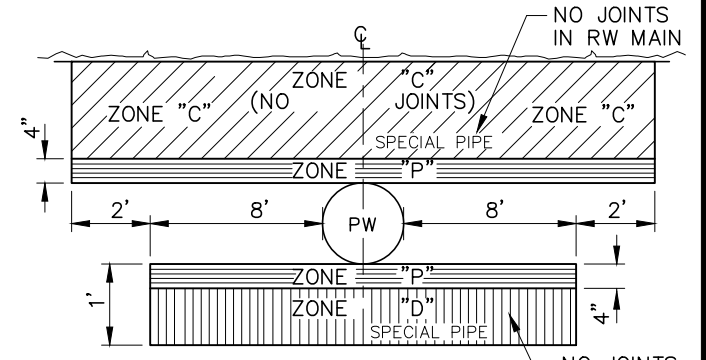

RECYCLED WATER MAIN CROSSING POTABLE WATER MAINS

NOTE: "P" IS A PROHIBITED CONSTRUCTION ZONE.

MOULTON NIGUEL WATER DISTRICT
DESIGN CRITERIA FOR SEPARATION OF POTABLE WATER AND SEWER MAINS FOR NEW RECYCLED WATER MAINS

RW-1
JANUARY 2019

GENERAL SEWER NOTES

1. ALL MNWD GENERAL CONSTRUCTION NOTES SHALL APPLY (PER MNWD STANDARD DRAWING G-GN).
2. ANY WORK TO BE PERFORMED INSIDE A LIVE MANHOLE SHALL BE DONE IN ACCORDANCE WITH CAL OSHA "CONFINED SPACES" AND DISTRICT MANHOLE ENTRY REGULATIONS. MANHOLE ENTRY WITHOUT DISTRICT APPROVAL AND DISTRICT PERSONNEL PRESENT IS NOT ALLOWED.
3. BYPASS PUMPING OF SEWAGE SHALL REQUIRE AN ENGINEERED BYPASS PLAN, TO BE SUBMITTED FOR REVIEW AND ACCEPTANCE BY MNWD STAFF, PER MNWD STANDARD SPECIFICATION 01550 BYPASS PUMPING. BYPASS PLAN MAY INCLUDE: PUMPS AND ABOVE-GROUND HDPE OR VICTAULIC-COUPLED TEMPORARY PIPELINES TO AN AVAILABLE DOWNSTREAM MANHOLE, PUMPING SEWAGE INTO TANKER TRUCKS AND DISCHARGING INTO A SEWER MANHOLE AS DIRECTED BY MNWD, AND/OR FLOW THROUGH PLUGS INSTALLED BETWEEN EXISTING AND NEWLY INSTALLED SEWER MAINS. REGULAR FLOWS SHOULD BE REESTABLISHED AT THE END OF EACH WORK DAY. ALL BYPASS EFFORTS SHALL BE MONITORED FULL TIME FOR THE DURATION OF THE BYPASS.
4. SEWER MAINS SHALL BE INSTALLED 5 FEET OFF THE STREET CENTERLINE UNLESS SHOWN OTHERWISE ON PLANS, OR AS STAKED BY THE APPLICANT'S SURVEYOR AT A MINIMUM 50-FOOT STATIONING IF NOT WITHIN A ROADWAY.
5. MNWD WILL INSPECT AND MAINTAIN ALL PUBLICLY-OWNED SEWERS AND MANHOLES. THE DISTRICT WILL NOT INSPECT NOR MAINTAIN PRIVATE LATERALS. THE ORANGE COUNTY DEPARTMENT OF BUILDING AND SAFETY, THE GOVERNING MUNICIPALITY, OR APPROPRIATE GOVERNING AGENCY WILL INSPECT AND VERIFY ALL PRIVATELY OWNED LATERALS TO THE BUILDINGS.
6. ALL SEWER MAINS SHALL BE REQUIRED TO PASS PRESSURE, LEAKAGE, INFILTRATION, AND DEFLECTION TESTING PER SECTION 15043 OF THE STANDARD SPECIFICATIONS OF THE MOULTON NIGUEL WATER DISTRICT PRIOR TO ACCEPTANCE.
7. THE CONTRACTOR SHALL BE RESPONSIBLE FOR BRINGING MANHOLES TO GRADE AFTER FINAL PAVEMENT IS PLACED.
8. ALL SEWER LATERAL TIE-INS SHALL BE MADE IN THE PRESENCE OF AN AUTHORIZED DISTRICT INSPECTOR.
9. ALL SEWER MANHOLE LIDS SHALL BE AS SHOWN IN STANDARD DRAWINGS S-3 AND S-4 OF MOULTON NIGUEL WATER DISTRICT'S "STANDARD SPECIFICATIONS FOR CONSTRUCTION OF POTABLE WATER, RECYCLED WATER, AND WASTEWATER FACILITIES."
10. CURBS SHALL BE INSCRIBED WITH A 2-INCH HIGH "S" INDICATING LOCATION OF ALL SEWER LATERALS.

MOULTON NIGUEL WATER DISTRICT

GENERAL SEWER NOTES

S-GN
JANUARY 2019

TOP OF PVMT. OR
EXIST. GRADE

SEE STD DWG S-3 & S-4
FRAME & COVER DETAILS
2" MIN A.C. PAVEMENT

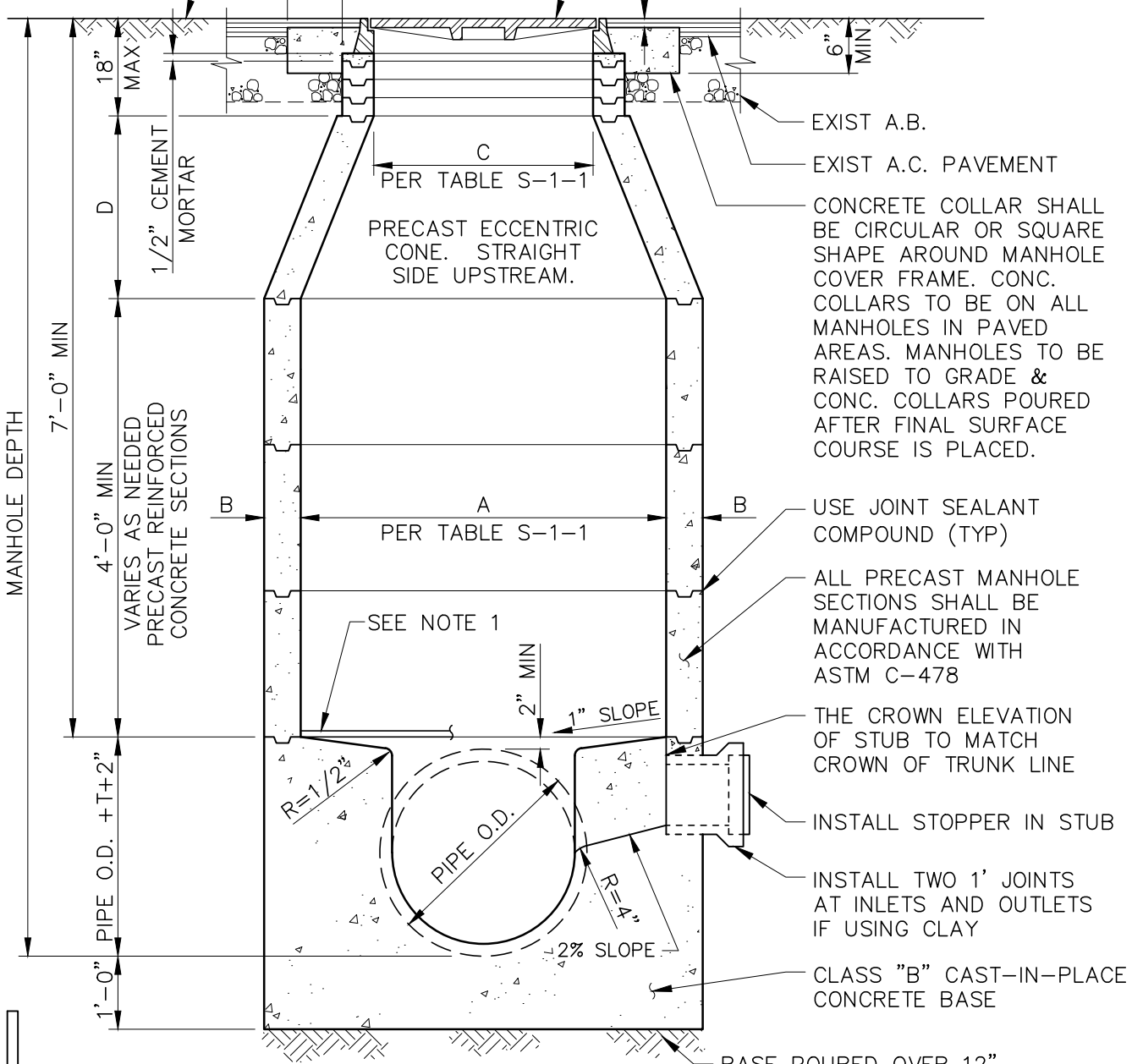

EXIST A.B.
EXIST A.C. PAVEMENT
CONCRETE COLLAR SHALL BE CIRCULAR OR SQUARE SHAPE AROUND MANHOLE COVER FRAME. CONC. COLLARS TO BE ON ALL MANHOLES IN PAVED AREAS. MANHOLES TO BE RAISED TO GRADE & CONC. COLLARS POURED AFTER FINAL SURFACE COURSE IS PLACED.

USE JOINT SEALANT COMPOUND (TYP)

ALL PRECAST MANHOLE SECTIONS SHALL BE MANUFACTURED IN ACCORDANCE WITH ASTM C-478

THE CROWN ELEVATION OF STUB TO MATCH CROWN OF TRUNK LINE

INSTALL STOPPER IN STUB

INSTALL TWO 1' JOINTS AT INLETS AND OUTLETS IF USING CLAY

CLASS "B" CAST-IN-PLACE CONCRETE BASE

MANHOLE DEPTH
7'-0" MIN

18" MAX

1/2" CEMENT MORTAR

D

PER TABLE S-1-1

PRECAST ECCENTRIC CONE. STRAIGHT SIDE UPSTREAM.

C

PER TABLE S-1-1

4'-0" MIN

VARIES AS NEEDED PRECAST REINFORCED CONCRETE SECTIONS

B

A

PER TABLE S-1-1

SEE NOTE 1

2" MIN

1" SLOPE

PIPE O.D.

R=1/2"

R=4"

2% SLOPE

1'-0"

PIPE O.D. + T+2"

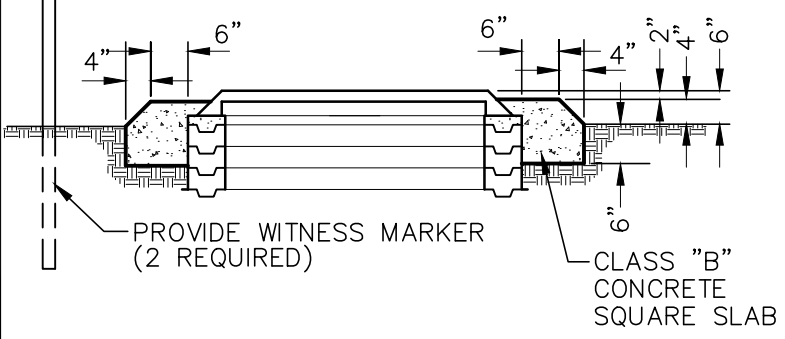

PROVIDE WITNESS MARKER (2 REQUIRED)

CLASS "B" CONCRETE SQUARE SLAB

TOP OF MANHOLE
IN UNIMPROVED AREA

BASE POURED OVER 12" OF COMPACTED 3/4" ROCK

TABLE S-1-1

MH. DEPTH	A	B	C	D
<12'	48"	6"	24"	24"
12'-16'	60"	6"	36"	32"
16'<	72"	7"	36"	36"

NOTES:

- LADDER RUNGS SHALL NOT BE INSTALLED IN MANHOLE SECTIONS.
- MANHOLES LOCATIONS SHALL BE ETCHED ON CURB FACE.

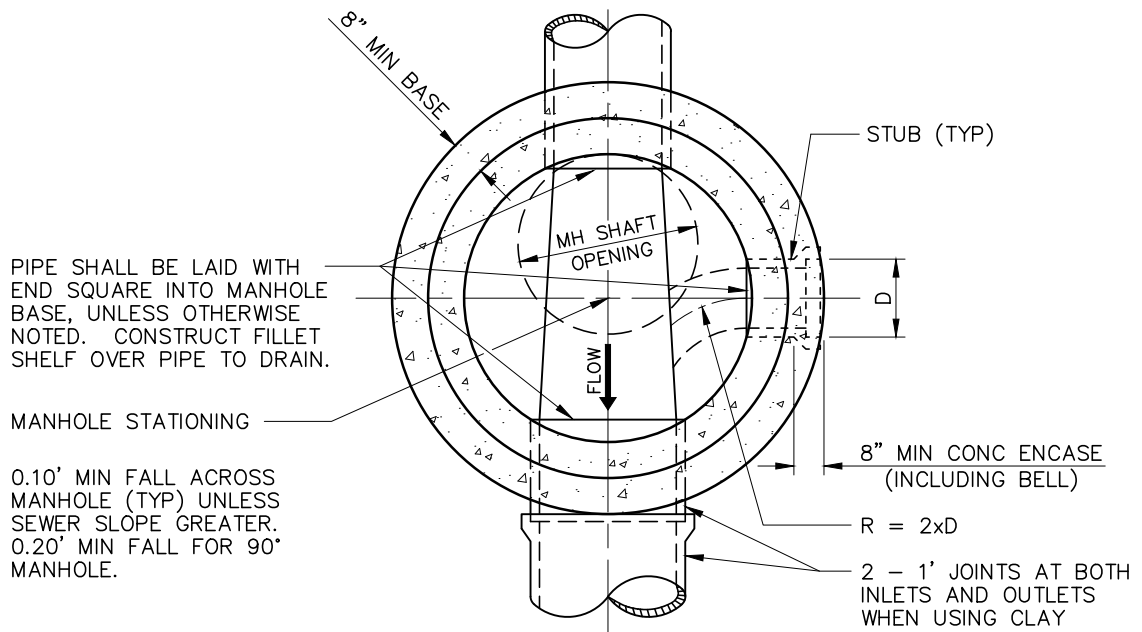

PLAN

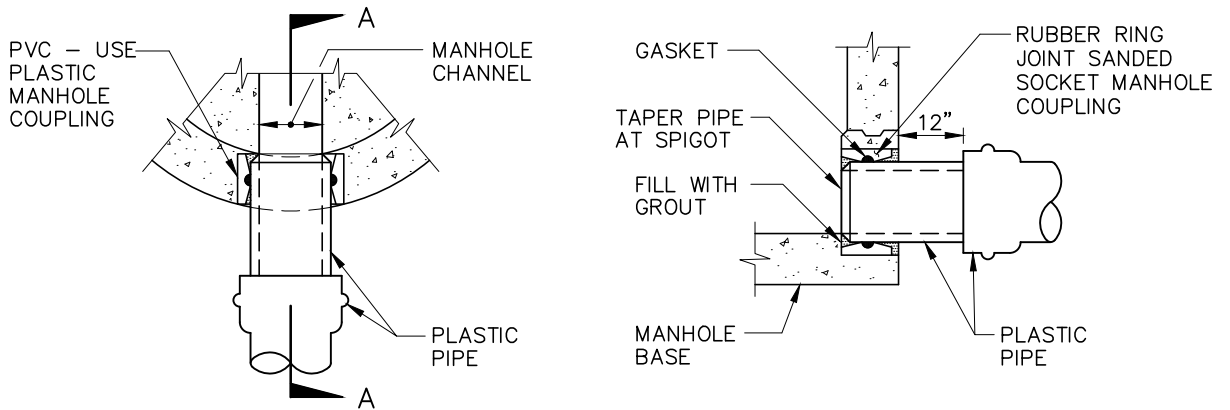

PLAN

SECTION A-A

MANHOLE CONNECTION DETAILS

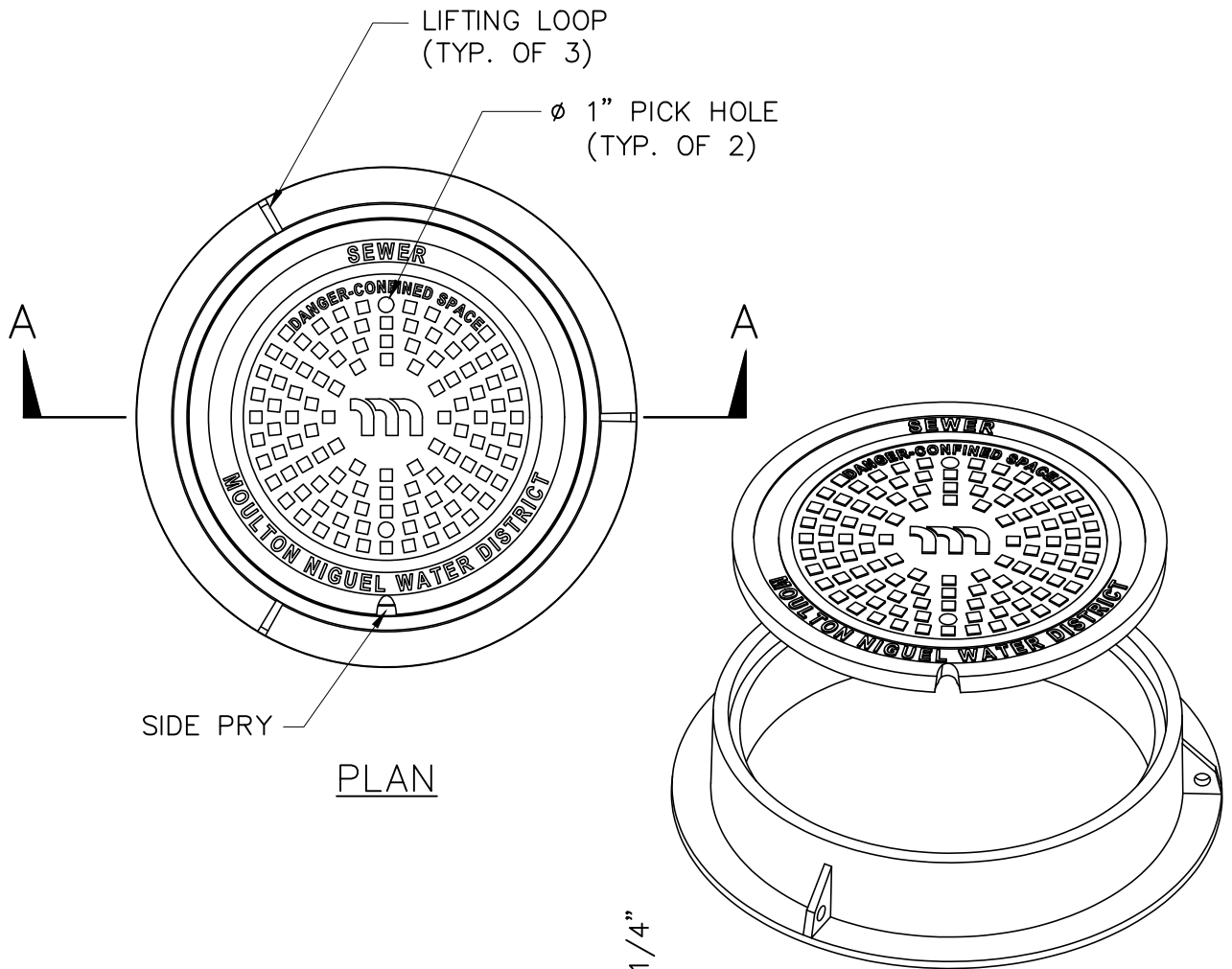

SIDE PRY

PLAN

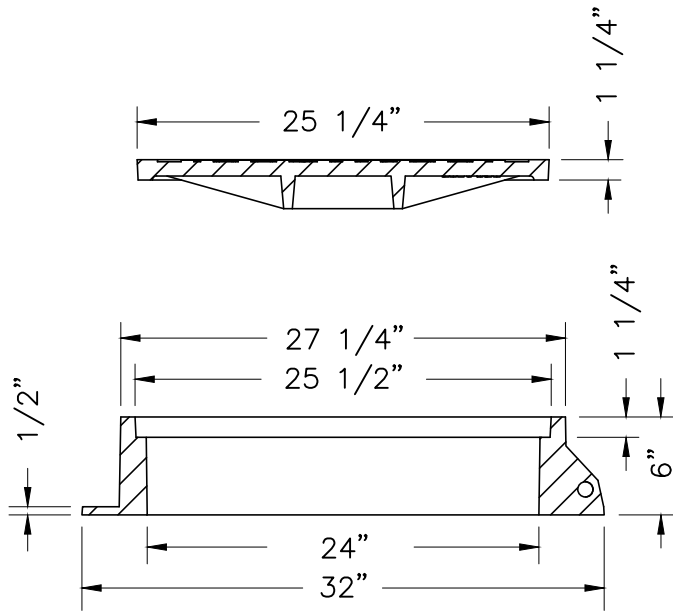

SECTION A-A

MOULTON NIGUEL WATER DISTRICT		S-3 JANUARY 2019
MANHOLE FRAME AND COVER FOR 48" MANHOLE		

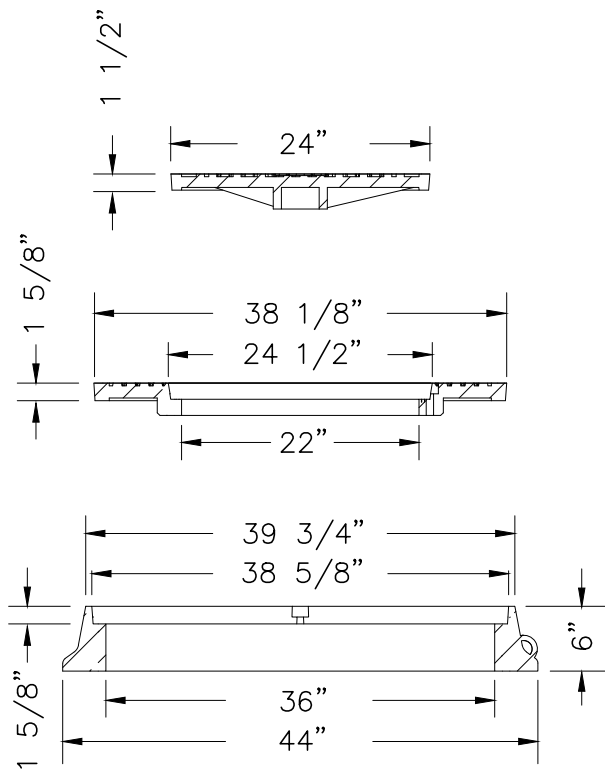
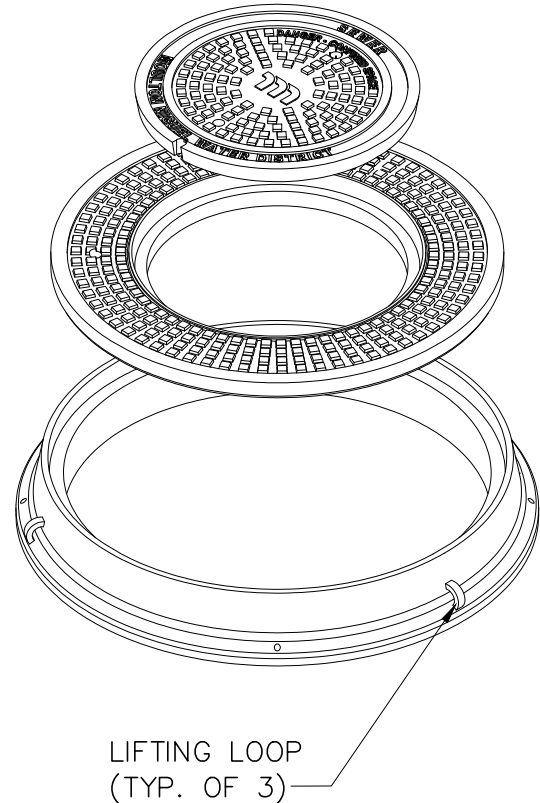
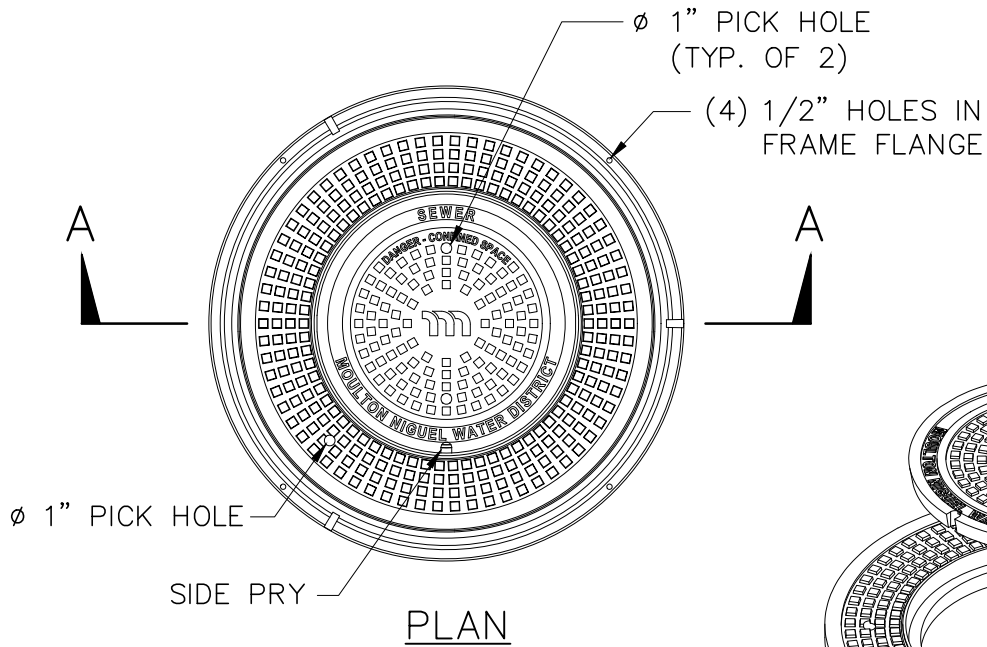

SECTION A-A

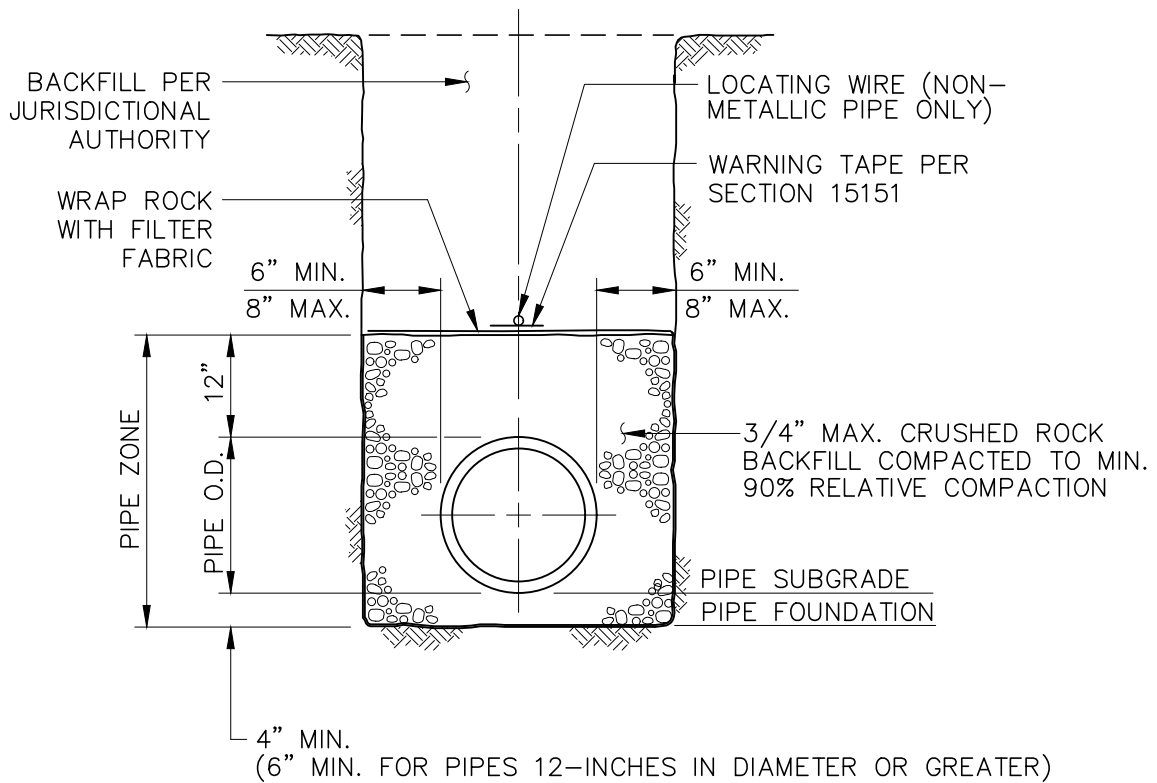

NORMAL BEDDING

NOTES:

1. NORMAL BEDDING SHALL BE USED FOR DEPTH OF COVER >4' OR <17' FOR PIPE BEDDING FOR DEPTH OF COVER >17' TO BE DETERMINED BY THE DISTRICT.
2. CONCRETE ENCASEMENT SHALL BE USED WHERE THE TRENCH WIDTH AT THE UPPER LIMITS OF THE PIPE ZONE EXCEEDS THE MAX. WIDTH SPECIFIED ABOVE.
3. SEE STD. DWGS. S-1 AND S-2 FOR MANHOLE DETAILS.
4. AFTER COMPACTION OF THE BACKFILL HAS BEEN ACHIEVED, ALL SEWER PIPE SHALL BE MANDREL TESTED, AIR TESTED AND VIDEOED PRIOR TO PAVEMENT AND HOUSE CONNECTION.
5. ALL EXCAVATIONS AND TRENCHES SHALL BE PROTECTED IN ACCORDANCE WITH THE CALIFORNIA DEPARTMENT OF INDUSTRIAL RELATIONS (CALOSHA) CODE OF REGULATIONS TITLE 8, SUBCHAPTER 4 "CONSTRUCTION SAFETY ORDERS".
6. OVEREXCAVATE TO REMOVE UNSUITABLE SOIL IF NECESSARY AND RE-ESTABLISH GRADE WITH 3/4" CRUSHED ROCK. DISTRICT TO DETERMINE DEPTH AND WIDTH OF REMOVAL.

MOULTON NIGUEL WATER DISTRICT

PVC & VCP PIPE BEDDING

S-5

JANUARY 2019

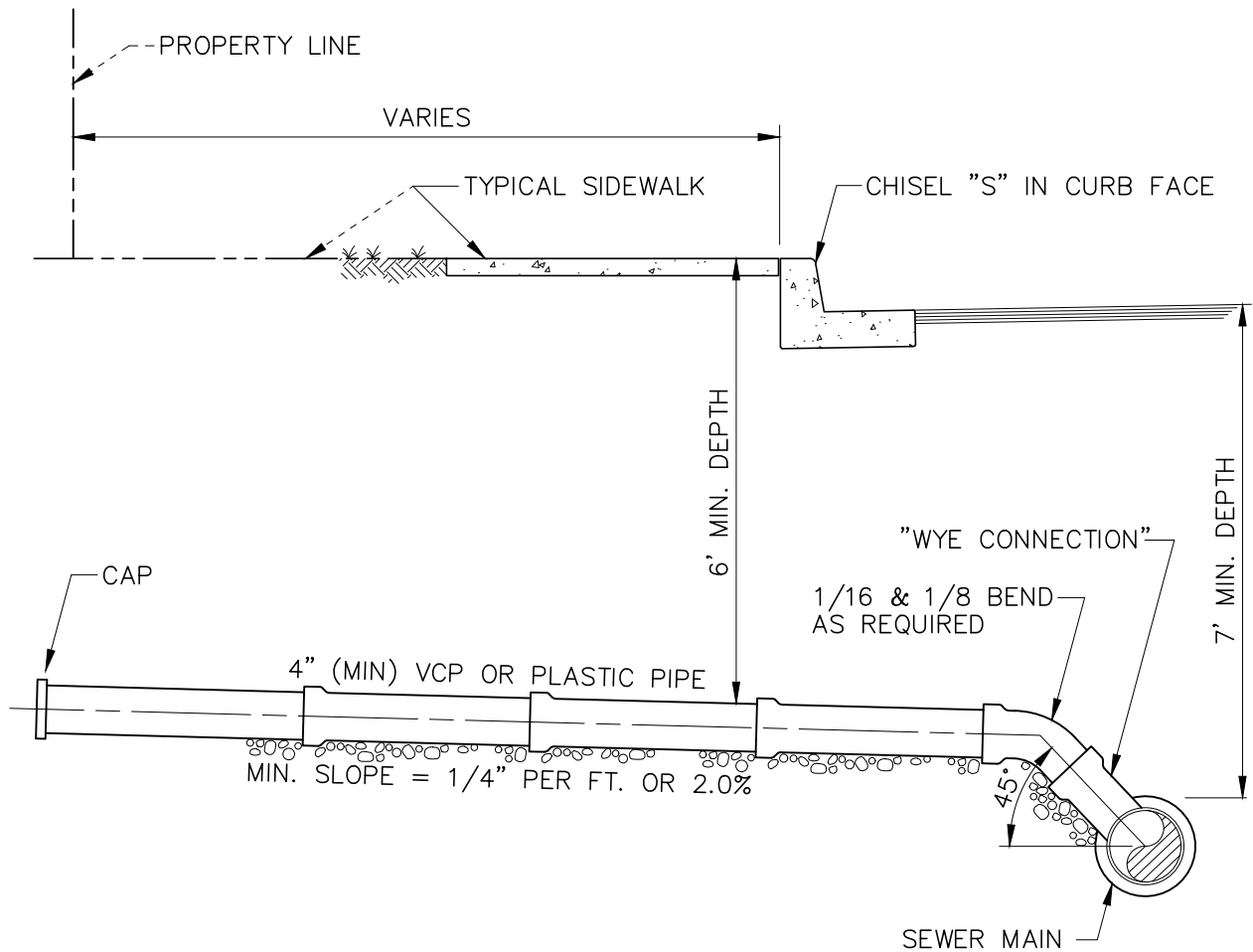

NOTES:

1. LATERAL SIZE TO BE DETERMINED ON THE BASIS OF TOTAL NUMBER OF FIXTURE UNITS DRAINED, BUT IN NO CASE SHALL THE LATERAL BE LESS THAN 4" FOR SINGLE OR MULTIPLE FAMILY RESIDENTIAL. SIX INCHES FOR COMMERCIAL OR INDUSTRIAL.
2. BEDDING AND BACKFILL OF LATERAL PER S-5 OR S-8.
3. WHERE SEWER WYE IS INSTALLED WITHOUT A HOUSE LATERAL, THE WYE SHALL BE PLUGGED WITH A SDR 35 PVC CAP.
4. LATERAL CONNECTION TO THE DISTRICT COLLECTION SYSTEM – SHALL BE CONSTRUCTED IN ACCORDANCE WITH COUNTY OF ORANGE, OR CITY REQUIREMENTS. PLUG AT PROPERTY LINE WITH SDR 35 PVC CAP.
5. PROPERTY OWNER IS REQUIRED TO MAINTAIN AND REPAIR LATERAL AND "WYE" CONNECTION, IT IS NOT MNWD RESPONSIBILITY.
6. LOCATE SEWER WITH A 2" HIGH "S" CHISELED IN CURB FACE WHERE THE LATERAL CROSSES UNDER THE CURB. WHERE NO CURB EXISTS, OR WHERE THE LATERAL ENDS 8' OR MORE BACK OF CURB, PLACE A 4" X 4" X 3'-0" STAKE EXTENDING 2" ABOVE FINISHED GRADE.

MOULTON NIGUEL WATER DISTRICT

TYPICAL HOUSE LATERAL

S-6

JANUARY 2019

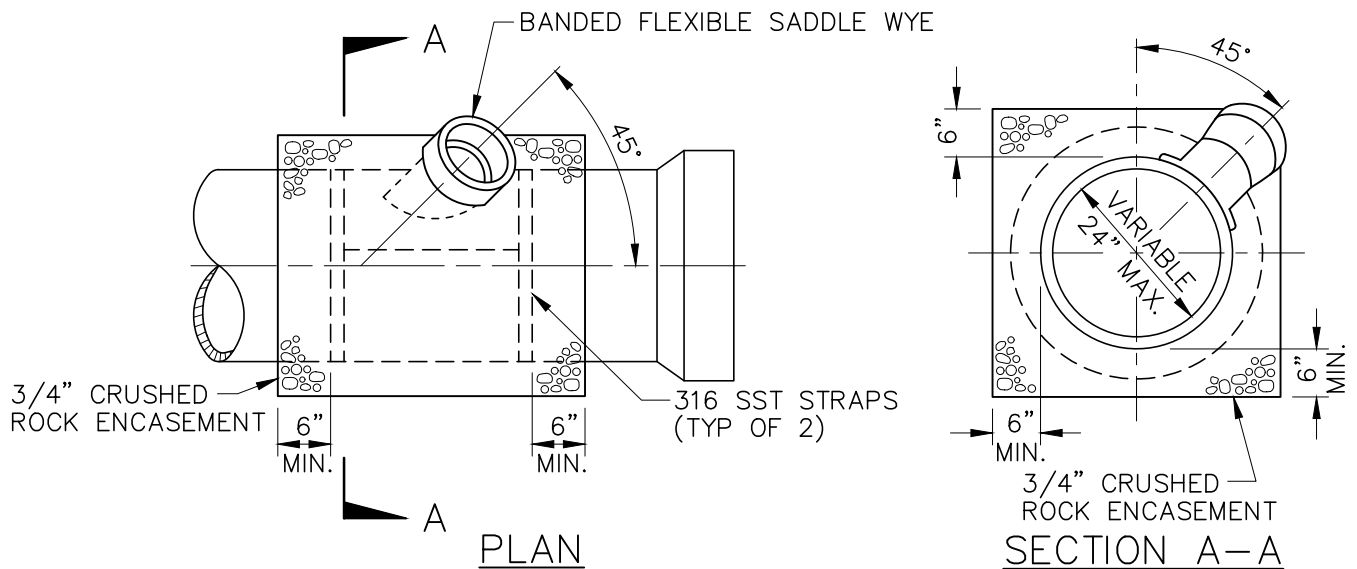

BANDED FLEXIBLE SADDLE WYE CONNECTION

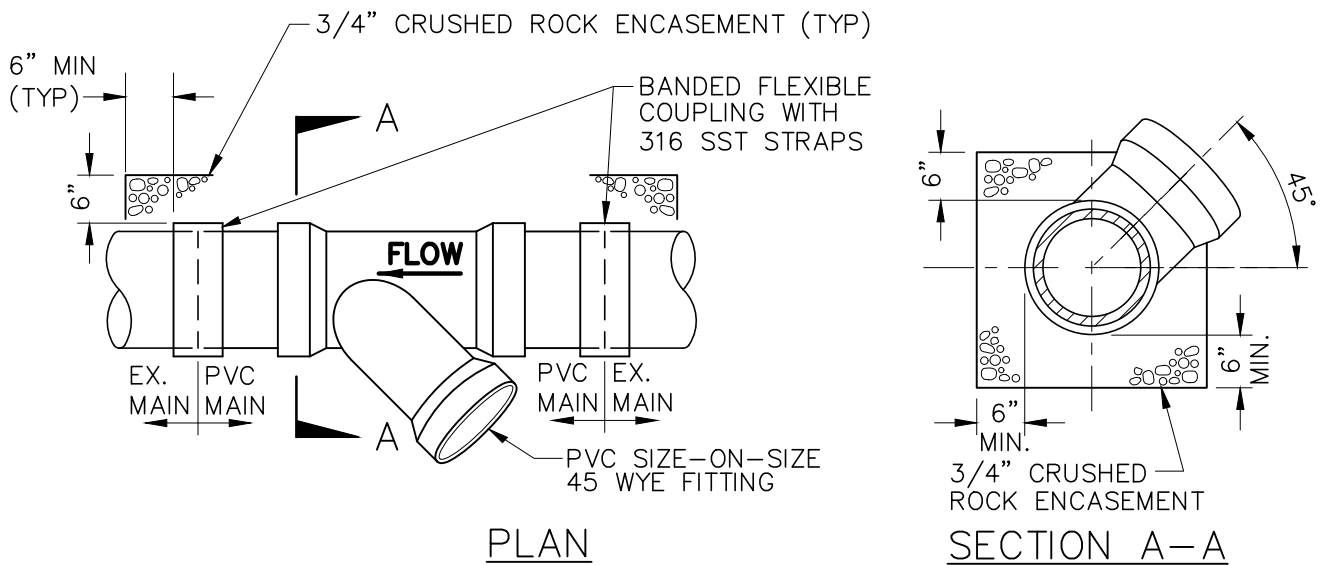

CUT-IN WYE CONNECTION

NOTES:

1. BANDED FLEXIBLE SADDLE WYES SHALL BE USED WHEN CONNECTING A SMALLER SIZED LATERAL TO A LARGER SIZED MAIN. A CUT-IN WYE SHALL BE USED WHEN LATERAL CONNECTION IS SIZE-ON-SIZE WITH THE MAIN.
2. THE HOLE FOR THE SEWER SADDLE WYE SHALL BE MADE WITH A TAPPING MACHINE. THE HOLE SHALL BE CLEANLY MACHINED AND IF NECESSARY WORKED BY HAND WITH A RASP OR SANDED TO ACCOMPLISH A TRUE AND NEAT OPENING FOR THE SADDLE WYE.
3. THE APPLICANT SHALL ENCASE SADDLE CONNECTION AND CUT-IN WYES WITH 3/4" CRUSHED ROCK AFTER THE CONNECTION IS APPROVED BY THE INSPECTOR TO THE LIMITS INDICATED ABOVE. CRUSHED ROCK ENCASEMENT TO EXTEND 6 INCHES (MIN) BEYOND STRAPS OF BANDED SADDLE OR BANDED COUPLINGS. VIBRATE CRUSHED ROCK TO COMPACT.
4. THE APPLICANT SHALL KEEP ALL CHIPS, DIRT, EPOXY, MORTAR, AND CONCRETE OUT OF THE SEWER SADDLED, AND SHALL PERFORM A CLEANING AND BAILING OF THE REACH SADDLED IF DIRECTED TO DO SO BY THE INSPECTOR.
5. THE APPLICANT SHALL REPAIR OR REPLACE ANY DAMAGED PIPE AS DIRECTED BY THE INSPECTOR.

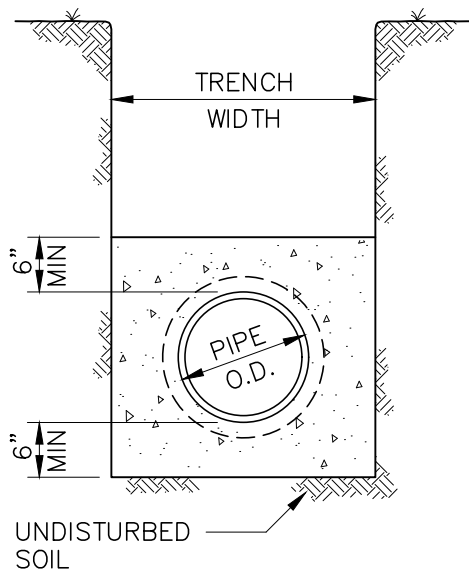

TYPE "A"

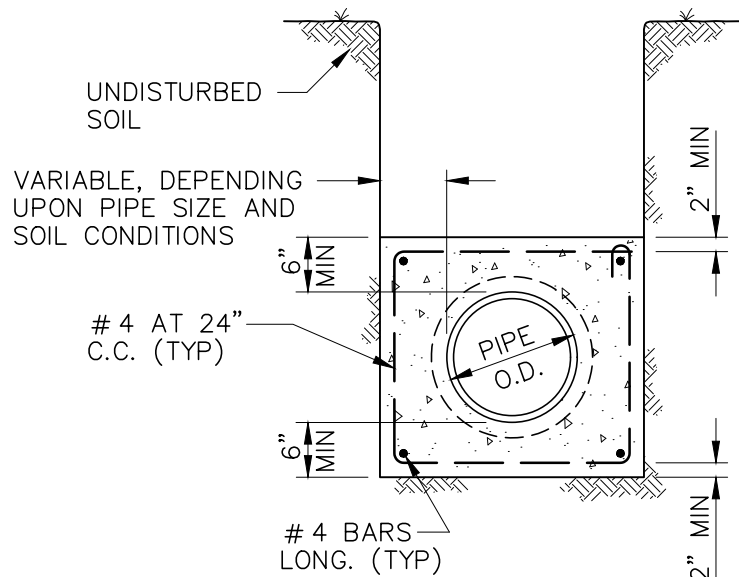

TYPE "B"

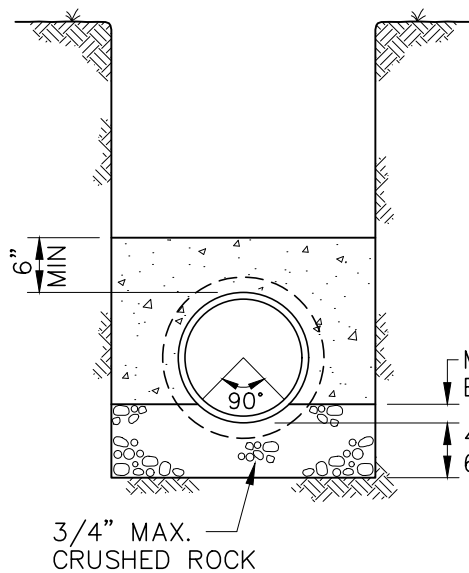

TYPE "C"

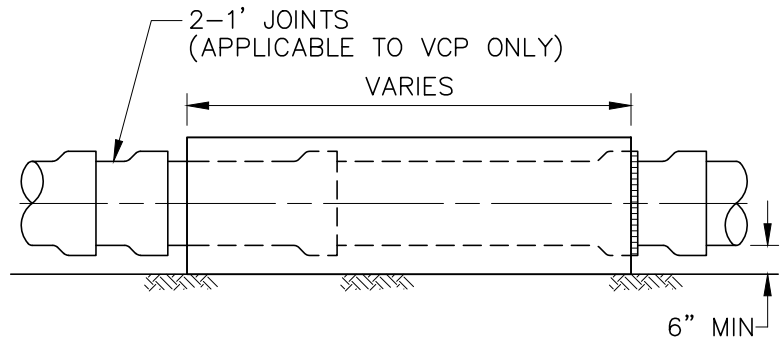

SECTION

NOTES:

1. USE CONCRETE ENCASEMENT WHEN COVER IS UNDER 4' OR OVER 17'.
2. PLACE ENCASEMENT AGAINST UNDISTURBED NATURAL GROUND OR FILL COMPACTED TO 90% RELATIVE COMPACTION.
3. NO. 4 STEEL REINFORCING BARS UNLESS OTHERWISE NOTED.
4. USE TYPE OF CONCRETE ENCASEMENT AS SHOWN ON PLANS OR AS SPECIFIED BY INSPECTOR TO MEET UNFORESEEN CONDITIONS.
5. PROVIDE VERTICAL TRENCH WALLS FOR A MINIMUM OF 12" ABOVE TOP OF PIPE.
6. ENCASEMENT CONCRETE TO BE CLASS "B" PER SECTION 03300.
7. FOR DUCTILE IRON PIPE, CONTINUE POLYETHYLENE ENCASEMENT THROUGH CONCRETE ENCASEMENT.

MOULTON NIGUEL WATER DISTRICT

CONCRETE ENCASEMENT TYPE A, B & C

S-8

JANUARY 2019

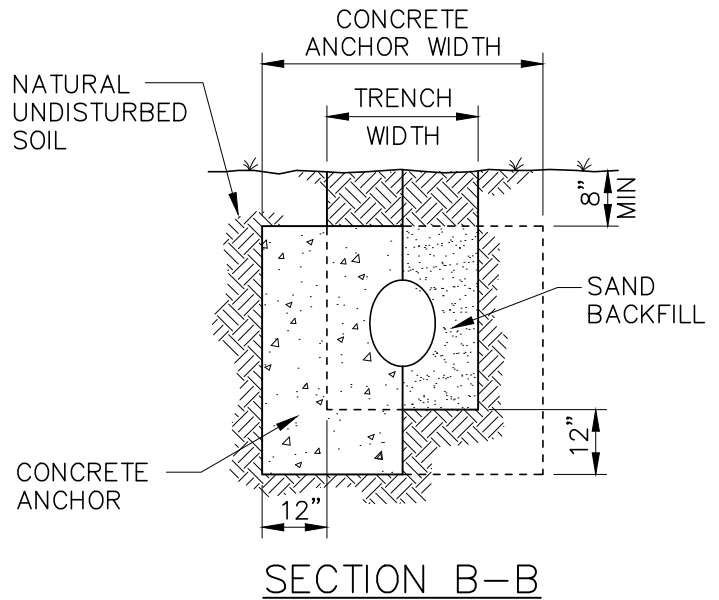
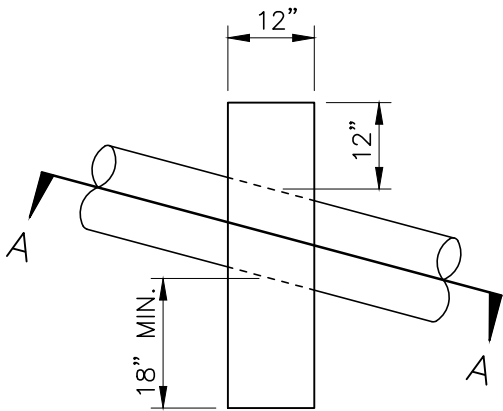
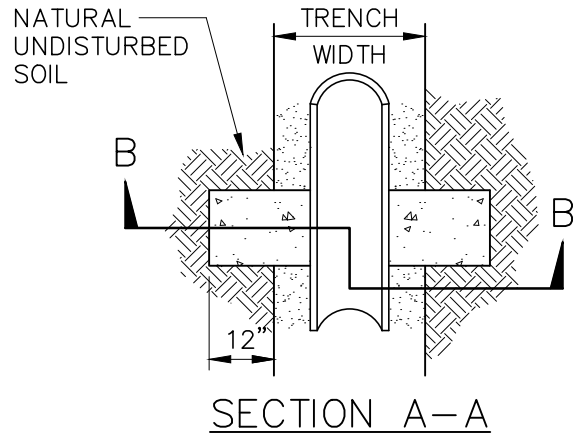
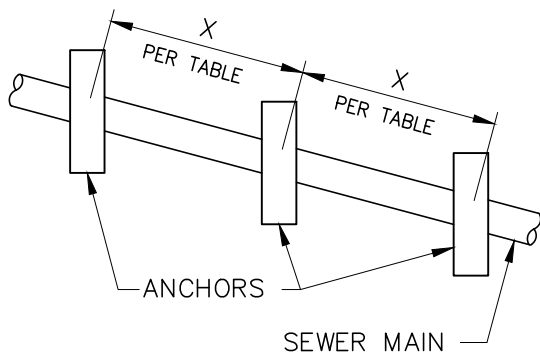

TABLE

PIPE SLOPE	X DISTANCE
20% TO 35%	36'
35% TO 50%	24'
> 50%	16'

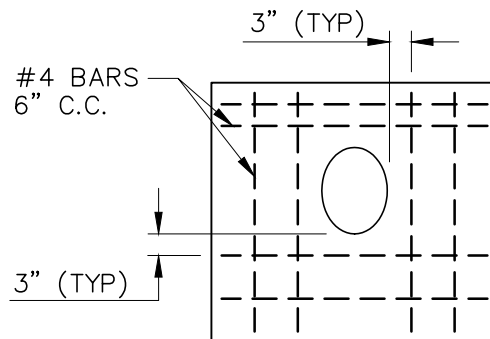

REINFORCING STEEL PATTERN

NOTES:

1. PIPE ANCHORS REQUIRED ON ALL SLOPES OF 20% OR GREATER.
2. ANCHOR SHALL EXTEND 12" INTO NATURAL UNDISTURBED SOIL.
3. CONCRETE SHALL BE CLASS "B" PER SECTION 03300.
4. ANCHORS FOR TRAPEZOIDAL TRENCH SECTIONS WILL CONFORM TO TRENCH CROSS SECTION AND EXTEND 12" INTO UNDISTURBED SOIL.

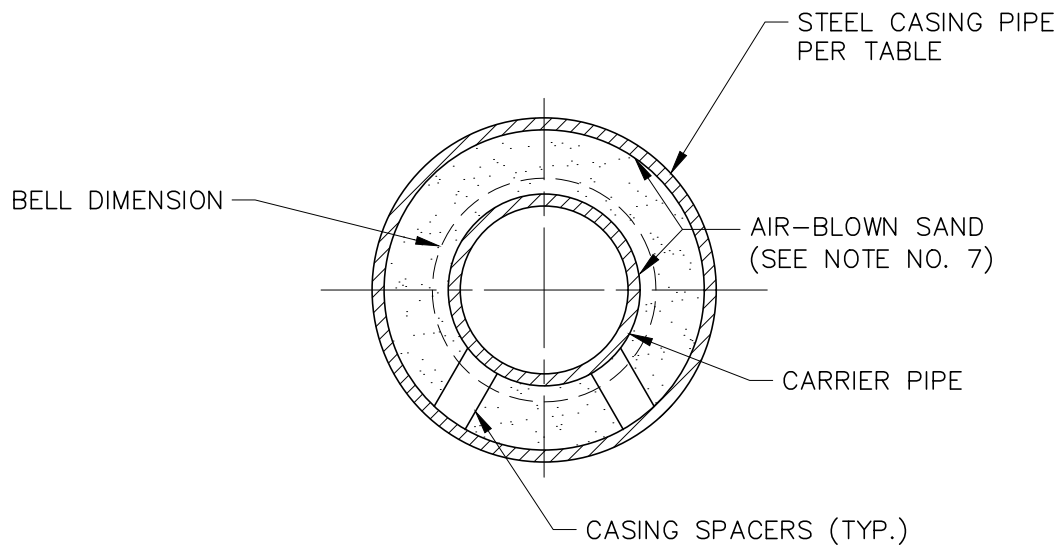

STEEL CASING DIMENSION TABLE

<u>PVC SIZE</u>	<u>MIN. CASING SIZE</u>	<u>MIN. CASING THICKNESS</u>	<u>VCP SIZE</u>	<u>MIN. CASING SIZE</u>	<u>MIN. CASING THICKNESS</u>
6"	12" I.D.	1/4"	6"	16" I.D.	1/4"
8"	16" I.D.	1/4"	8"	18" I.D.	1/4"
10"	18" I.D.	5/16"	10"	21" I.D.	5/16"
12"	20" O.D.	5/16"	12"	24" O.D.	5/16"

NOTES:

1. CASING SHALL BE INSTALLED BY THE BORE, JACK AND/OR TUNNEL METHOD.
2. CARRIER PIPE SHALL BE AIR TESTED PRIOR TO FILLING CASING.
3. UPSTREAM AND DOWNSTREAM ELEVATIONS TO BE VERIFIED PRIOR TO FILLING CASING.
4. ALL CASING SECTIONS TO BE JOINED BY CONTINUOUS WELD.
5. CASING SHALL BE SEALED WITH AN END SEAL.
6. ALL PIPE JOINTS WITHIN THE CASING SHALL BE RESTRAINED.
7. UNLESS OTHERWISE NOTED ON THE PLANS, THE ANNULAR SPACE WITHIN THE CASING SHALL BE FILLED WITH AIR BLOWN SAND.

MOULTON NIGUEL WATER DISTRICT

STEEL CASING PIPE

S-10
JANUARY 2019

GENERAL NOTE

THE STATE WATER RESOURCES CONTROL BOARD (SWRCB) AND STATE OF CALIFORNIA REGULATIONS (TITLE 22, CHAPTER 16 SECTION 64572) SHALL BE FOLLOWED WHEN DESIGNING AND CONSTRUCTING NEW POTABLE WATER, RECYCLED WATER, AND SEWER MAINS. WHEN SWRCB AND DISTRICT STANDARDS CONFLICT, THE MOST STRINGENT REQUIREMENT SHALL APPLY UNLESS OTHERWISE APPROVED BY THE DISTRICT.

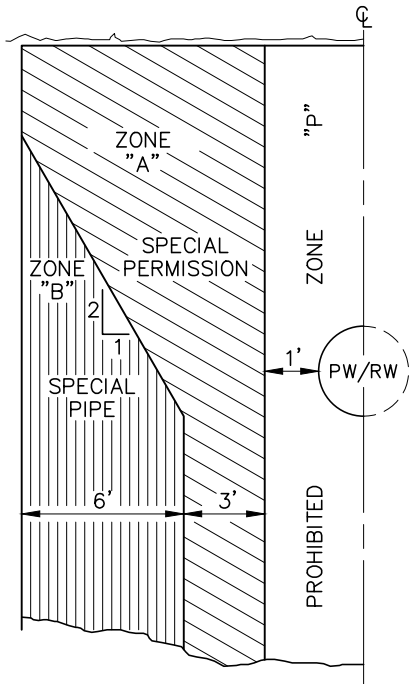

SEWER MAIN PARALLEL TO POTABLE/RECYCLED WATER MAIN

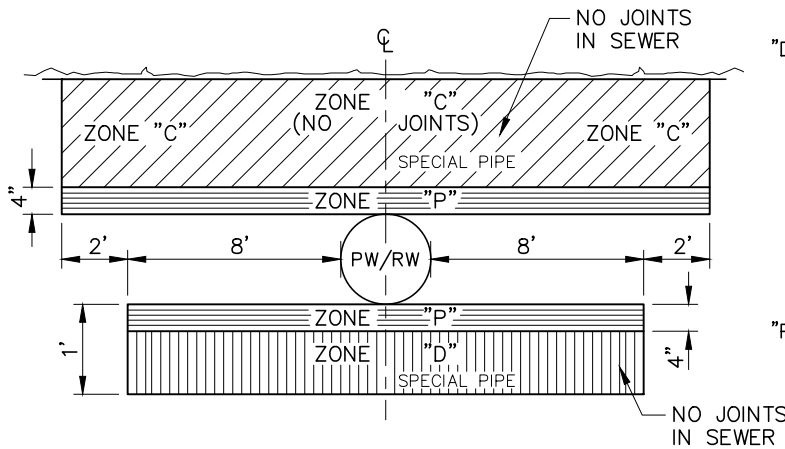

NOTE: "P" IS A PROHIBITED CONSTRUCTION ZONE.

SEWER MAIN CROSSING POTABLE/RECYCLED WATER MAIN

PW = POTABLE WATER MAIN
RW = RECYCLED WATER MAIN

BASIC SEPARATION STANDARDS

1. PARALLEL CONSTRUCTION: THE HORIZONTAL DISTANCE BETWEEN PRESSURE POTABLE WATER AND RECYCLED WATER MAINS AND SEWER LINES SHALL BE AT LEAST 10 FEET.
2. PERPENDICULAR CONSTRUCTION (CROSSING): PRESSURE POTABLE WATER MAINS SHALL BE AT LEAST ONE FOOT ABOVE SEWER AND RECYCLED WATER LINES WHERE THESE LINES MUST CROSS.

SPECIAL CONSTRUCTION REQUIRED FOR SEWER

ZONE

- "A" NO SEWER LINES PARALLEL TO POTABLE OR RECYCLED WATER LINES SHALL BE PERMITTED IN THIS ZONE WITHOUT APPROVAL FROM COUNTY AND STATE BOARD'S DIVISION OF DRINKING WATER AND THE DISTRICT. IF APPROVED, ZONE 'B' PIPE MATERIALS ARE REQUIRED UNLESS OTHERWISE REQUIRED.
- "B" SEWER MAIN SHALL BE CONSTRUCTED OF:
 1. SDR 35 PVC SEWER PIPE.
 2. EXTRA STRENGTH VITRIFIED CLAY PIPE.
 3. DUCTILE IRON PIPE WITH PUSH-ON JOINTS
- "C" A SEWER MAIN SHALL BE CONSTRUCTED OF:
 1. A CONTINUOUS SECTION OF SDR 35 PVC PIPE.
 2. CONTINUOUS SECTION OF DUCTILE IRON PIPE.
 3. ANY SEWER PIPE WITHIN A CONTINUOUS SLEEVE OR 6" THICK CONCRETE ENCASEMENT.
- "D" A SEWER MAIN SHALL BE CONSTRUCTED OF:
 1. A CONTINUOUS SECTION OF SDR 35 PVC PIPE.
 2. CONTINUOUS SECTION OF DUCTILE IRON PIPE.
 3. ANY SEWER PIPE WITHIN A CONTINUOUS SLEEVE OR 6" THICK CONCRETE ENCASEMENT.
 4. ANY SEWER PIPE SEPARATED BY A 10' X 10' X 4"-THICK REINFORCED CONCRETE SLAB.
- "P" NO SEWER MAIN SHALL BE CONSTRUCTED PER SECTION 64630 (2) CALIFORNIA ADMINISTRATIVE CODE, TITLE 22.

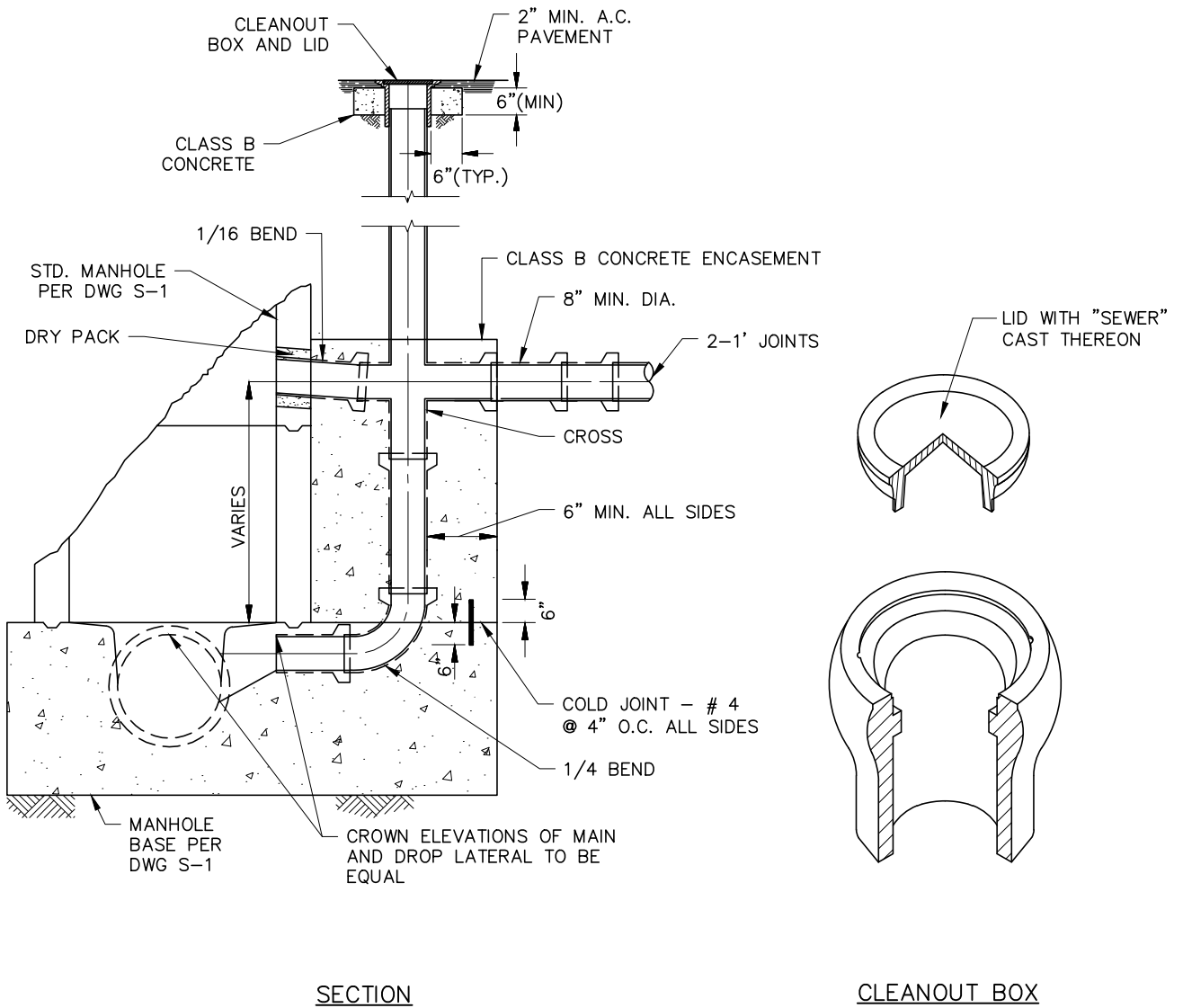

NOTES

1. DROP MANHOLE ONLY TO BE USED FOR SPECIAL SITUATIONS, AND SHALL NOT BE CONSTRUCTED WITHOUT DISTRICT APPROVAL.
2. ALL NEW OPENINGS CONSTRUCTED INTO MANHOLE SHALL BE DONE BY CORE DRILLING.
3. CONTRACTOR SHALL BE RESPONSIBLE FOR RAISING CLEANOUT BOXES TO GRADE AFTER STREET IS PAVED 1ST LIFT AND 2ND LIFT.

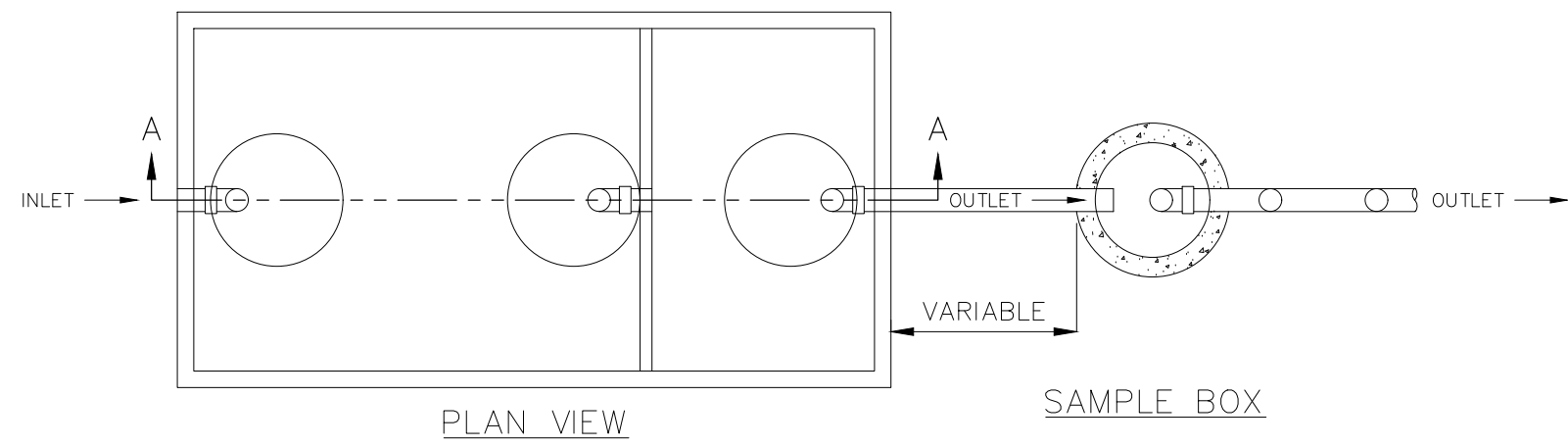

PLAN VIEW

SAMPLE BOX

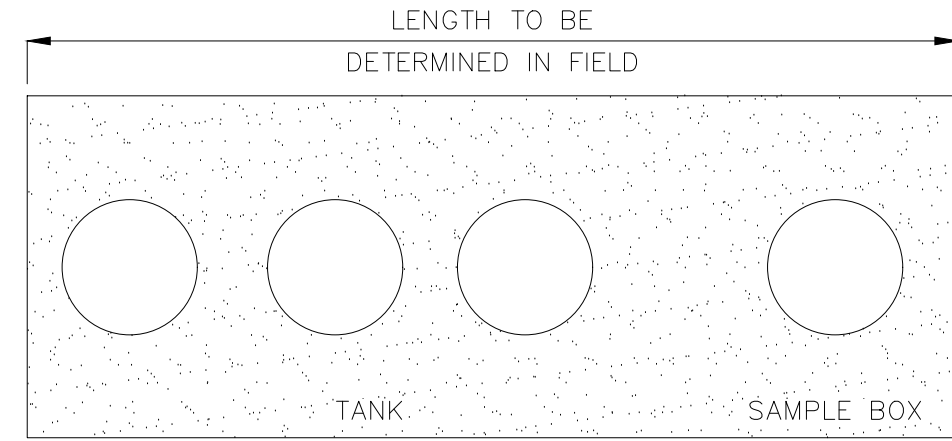

CONCRETE COLLAR DETAIL
PLAN VIEW

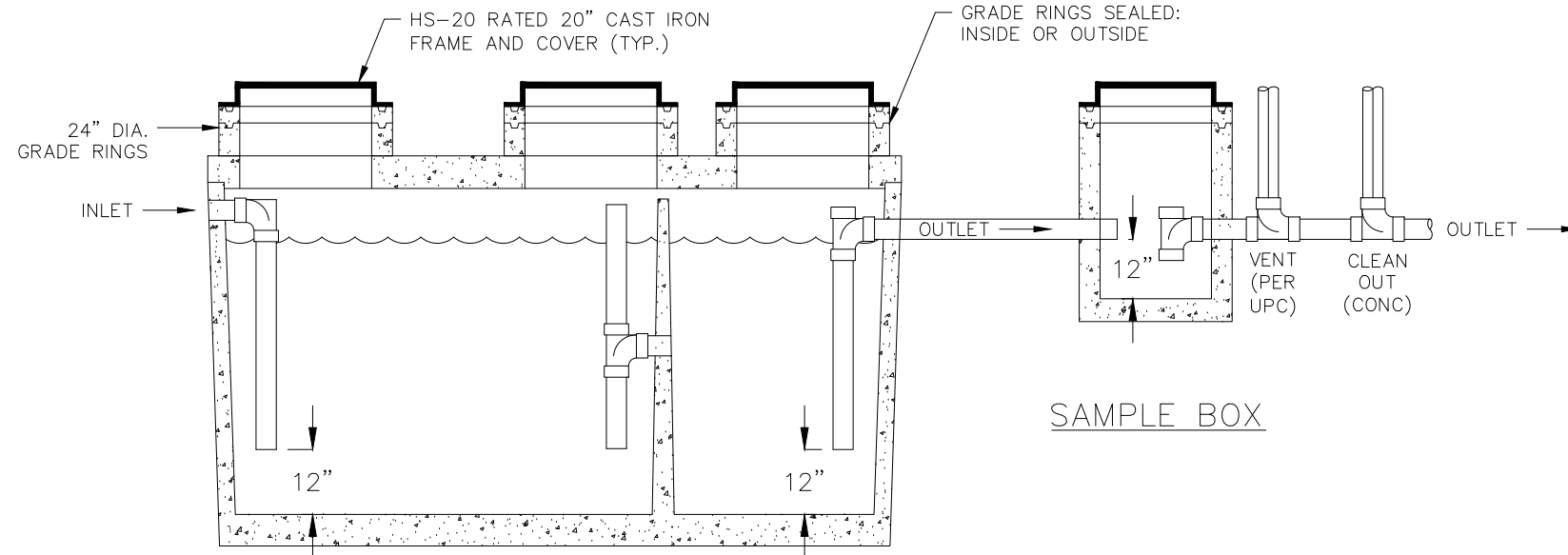

SIDE VIEW

SAMPLE BOX



CONCRETE COLLAR DETAIL
PLAN VIEW

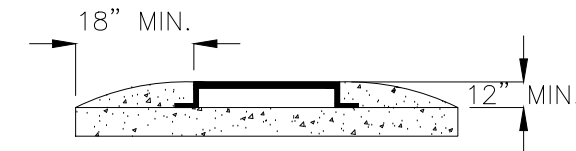

CONCRETE COLLAR DETAIL
PLAN VIEW

REQUIREMENTS:

1. SIZE AND LOCATION OF INTERCEPTOR TO BE APPROVED PRIOR TO INSTALLATION.
2. INTERCEPTOR TO INCLUDE:
 - A. SAMPLE BOX
 - B. SANITARY TEE; INSIDE SAMPLE BOX, DISCHARGE SIDE
 - C. VENT
 - D. CLEANOUT PRIOR TO LATERAL CONNECTION
 - E. MANHOLE AT EACH INTERNAL BAFFLE – NO MORE THAN 10' BETWEEN MANHOLES
 - F. OUTLET SHALL BE SAME DIAMETER AS INLET
 - G. INTERIOR OF INTERCEPTOR , INCLUDING ROOF, SHALL BE COATED WITH A PROTECTIVE COATING
3. INSPECTION OF INTERCEPTOR
 - A. ALL CONNECTIONS TO INTERCEPTOR TO BE INSPECTED BY THE DISTRICT INSPECTOR PRIOR TO BACKFILL
 - B. NOTIFY DISTRICT A MINIMUM OF 72 HOURS IN ADVANCE OF INSTALLATION TO SCHEDULE REQUIRED INSPECTIONS.
 - C. INTERCEPTOR TO BE FILLED WITH WATER PRIOR TO INSPECTION, PER MANUFACTURER'S INSTRUCTIONS OR REQUEST
4. ALL MANHOLES AND SAMPLE BOXES TO BE INSTALLED A MINIMUM OF 1/2" ABOVE FINISH GRADE/PAVEMENT WITH A CONCRETE COLLAR A MINIMUM OF 18" ROUND ALL MANHOLE LIDS AND 12" DEEP
5. MANHOLES SHALL BE GAS TIGHT WITH A MINIMUM OPENING DIMENSION OF TWENTY (20) INCHES
6. CONCRETE COLLAR, SAMPLE BOX FITTING AND ALL EXTERIOR PIPING SUPPLIED BY INSTALLER
7. A SOILS INSPECTION REPORT IS REQUIRED BY A STATE LICENSED GEOTECHNICAL SOILS ENGINEER. SUBGRADE AND ALL BACKFILL SHALL BE COMPACTED TO A MINIMUM OF 95% COMPACTION WHEN INSTALLED IN TRAFFIC AREA. WHEN INSTALLED OUTSIDE TRAFFIC AREAS, COMPACT TO 90% RELATIVE COMPACTION.

NOTE:

THE GREASE INTERCEPTOR SHALL BE SIZED USING THE CURRENT CALIFORNIA PLUMBING CODE

MINIMUM SIZE SHALL BE 750 GALLONS

MOULTON NIGUEL WATER DISTRICT

GREASE INTERCEPTOR
TANK WITH SAMPLE BOX

S-13
JANUARY 2019

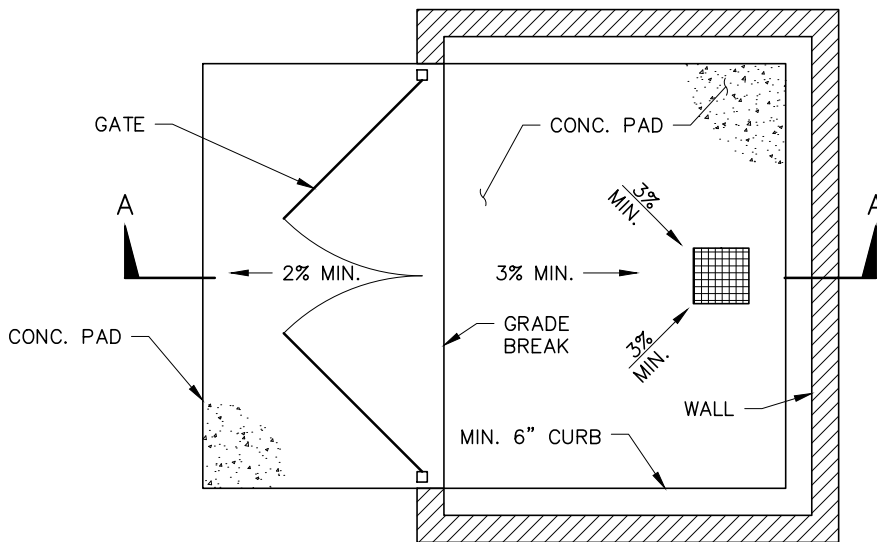
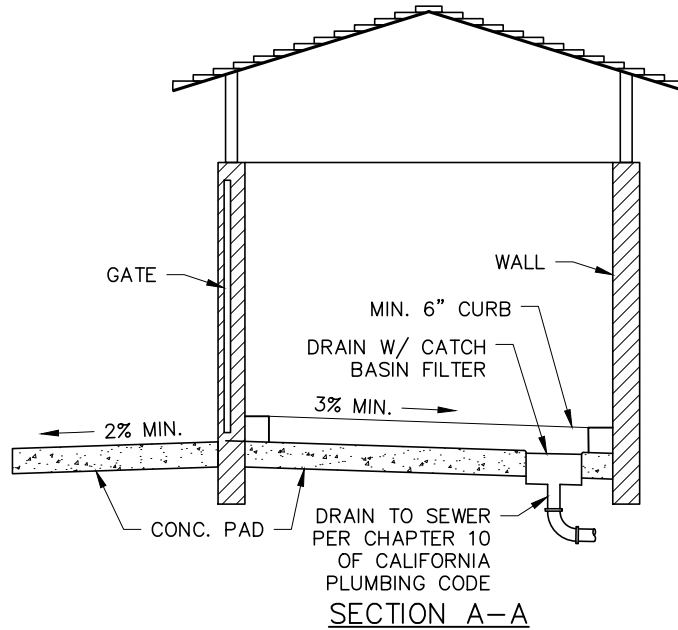

NOTES:

1. CONSTRUCT TRASH ENCLOSURE SO THAT NO STORMWATER OR DEBRIS IS ALLOWED TO ENTER THE DISTRICT'S SEWER SYSTEM.
2. TRASH ENCLOSURE STRUCTURE PER CITY BUILDING DEPARTMENT.
3. ENCLOSURE DRAIN WITH CATCH BASIN FILTER.
4. CONSTRUCT GATE AT GRADE BREAK.

APPROVED MATERIALS LIST

GENERAL

- A. Unless otherwise stated, all listed manufacturers and models shall allow for “or-equal” consideration per specification Section 01630.

SECTION 03300 CONCRETE

- A. Form Ties
 - 1. Burke Penta-Tie System
 - 2. Dayton Superior Snap-Ties
- B. Admixtures
 - 1. Sika Corporation
 - 2. BASF
 - 3. GCP
- C. Mechanical Couplers
 - 1. Dayton Superior Dowel Bar
 - 2. Erico Products Lenton Form Saver

SECTION 03461 PRECAST REINFORCED CONCRETE MANHOLES

- D. Precast Reinforced Concrete Products
 - 1. Jensen Precast
 - 2. Old Castle Precast
 - 3. Precon Products
- E. Cast Iron Frame and Covers
 - 1. Standard
 - a. Alhambra Foundry
 - b. Neenah Foundry
 - c. Long Beach Iron Works
 - d. South Bay Foundry
- F. Composite Manhole Frames and Covers

- 1. GMI Composites
- G. Concrete Adhesive
 - 1. Sika Corporation

SECTION 03462 PRECAST CONCRETE VAULTS

- A. Precast Vaults and Meter Boxes
 - 1. J & R Products
 - 2. Jensen Precast
 - 3. Eisel Enterprises, Inc.
- B. Ladders
 - 1. Galvanized with ladderup – Alhambra A-3400
- C. Joint Sealing Compound
 - 1. Ram-Nek as manufactured by K.T. Snyder Company, Inc.
 - 2. ConSeal as manufactured by Concrete Sealants, Inc.
 - 3. EZ-Stik as manufactured by Press-Seal Gasket Corporation
- D. Waterproofing
 - 1. Grace Dehydratine 4

SECTION 03463 GREASE INTERCEPTORS

- A. Grease Interceptors
 - 1. Pro-Cast
 - 2. Jensen Precast

SECTION 09810 EPOXY COATING FOR SEWER MANHOLE REHABILITATION

- A. Coating
 - 1. Sauereisen Sewergard No. 210
 - 2. Warren Environmental S-301
 - 3. Quadex Structure Guard
- B. Repair materials
 - 1. Sauereisen Resurfacing Compound No. F-121

2. Warren M-301 Epoxy Mastic
3. CTS Cement Rapid Set Mortar Mix

SECTION 09900 PAINTING AND COATING

- A. Epoxy
 1. Tnemec Series L69
 2. Carboline Carboguard 890 VOC
 3. Sherwin Williams Macropoxy 646-100
- B. Epoxy (for immersion in potable or recycled water)
 1. Tnemec Series L140
 2. Carboline Carboguard 890 VOC
 3. Sherwin Williams Macropoxy 646-100PW
- C. Urethane
 1. Tnemec Series 1095
 2. Carboline Carbothane 134 MC
 3. Sherwin Williams Hi-solids Polyurethane 100
- D. High-Solids Epoxy
 1. Tnemec Series 22
 2. Carboline Phenoline 341
- E. Sulfide-Resistant Epoxy
 1. Tnemec Series 435
 2. Carboline Plasite 4450
- F. Bituminous Mastic
 1. Northtown Company 50-HT
 2. Christy's HD50

SECTION 13110 DISSIMILAR METAL CONNECTIONS

- A. Insulating Flange Kits
 1. PSI Linebacker
- B. Insulating Bushings
 1. Northtown Company

- C. Casing Spacers
 - 1. GPT - C8G-2
- D. Casing End Seals
 - 1. GPT – type KT
- E. Wax Tape Coating System
 - 1. Trenton
- F. Wax Tape Primer
 - 1. Trenton

SECTION 13121 CORROSION PROTECTION

- A. Weld Cap Primer
 - 1. Royston Roypbond Primer 747
- B. Weld Caps
 - 1. Royston Handy Cap
 - 2. Trenton

SECTION 15050 HOT TAP CONNECTIONS

- A. Tapping sleeves for taps smaller than the pipeline
 - 1. JCM
 - a. 432 SS
 - b. 462 SS
 - 2. Mueller H-304SS
 - 3. Romac SST or SST II
- B. Tapping sleeves for size on size taps
 - 1. Mueller H-616
- C. Tapping sleeves onto 14-inch and larger ACP
 - 1. Mueller H-304

SECTION 15056 DUCTILE-IRON PIPE AND FITTINGS

- A. Pipe

1. Pacific States Cast Iron Pipe Company
 2. U.S. Pipe
 3. American Pipe
- B. Push-On Joint Restraint Harness for Ductile Iron Pipe:
1. EBAA Iron Megalug Series
 2. Smith Blair Bell-Lock
 3. Romac
- C. Fittings
1. Tyler
 2. Trinity Valley
 3. Dayton
 4. Sigma
 5. Long Beach Iron
- D. Mechanical Joint Restraining System for Ductile Iron Pipe
1. EBAA Iron Megalug
 2. Smith Blair MJ-Lock
 3. Romac RomoGrip
- E. Mechanical Joint Restraining System for PVC Pipe
1. EBAA Iron Megalug Series
 2. Smith Blair MJ-Lock
 3. Romac PVC RomoGrip
- F. Plastic Film Wrap
1. Polyken 900
 2. Scotch wrap 50
- G. Ceramic Epoxy Lining
1. Induron Protecto 401
 2. Tnemec Perma-Shield PL Series 431
- H. Corrosion Guard
1. Christy's CG-15 Corrosion Guard
 2. Trenton

SECTION 15057 COPPER, BRASS, AND BRONZE PIPE FITTINGS AND APPURTENANCES

- A. Copper Tubing and Fittings
 - 1. Mueller Industries
- B. Customer Service Valve
 - 1. Jones
 - 2. Mueller
 - 3. A.Y. McDonald
- C. Corporation Stop
 - 1. Jones
 - 2. Mueller
 - 3. A.Y. McDonald
- D. Angle Meter Stop
 - 1. Jones
 - 2. Mueller
 - 3. A.Y. McDonald
- E. Service Saddle (for Ductile-Iron main)
 - 1. Jones
 - 2. Mueller
 - 3. A.Y. McDonald
- F. Service Saddles (for PVC main)
 - 1. Jones
 - 2. Mueller
 - 3. A.Y. McDonald
- G. Insulating Pipe
 - 1. Pipeline Coating and Engineering Co., 1566 East Slauson Avenue, Los Angeles
 - 2. Smith Blair
 - 3. Pipe Seal and Insulator Company

SECTION 15064 PVC PRESSURE DISTRIBUTION PIPE

- A. PVC Distribution Pipe
 - 1. North American Pipe Corporation

- 2. Vinyltech
- 3. Certainteed
- B. Push-On Joint Restraint Harness for PVC Pipe:
 - 1. EBAA Iron Megalug Series 1900
 - 2. Smith Blair Bell-Lock
 - 3. Romac

SECTION 15066 GRAVITY SEWER PIPELINES

- A. PVC Pipe
 - 1. Vinyltech
 - 2. Diamond Plastics
 - 3. Carlon
- B. PVC Fittings
 - 1. GPK Products
- C. Vitrified-Clay Pipe and Fittings
 - 1. Gladding McBean
 - 2. Mission Clay Products

SECTION 15068 SEWER LATERALS

- A. Banded Flexible Saddle Wyes
 - 1. Fernco
- B. Banded Flexible Coupling
 - 1. Fernco

SECTION 15089 AIR VALVES

- A. Combination Valves $\leq 2''$
 - 1. ARI
- B. Combination Valves $> 2''$
 - 1. APCO
 - 2. Val-Matic

- 3. Crispin
- 4. ARI
- C. Air Valve Enclosure
 - 1. Armorcast
 - 2. Pipeline Products

SECTION 15100 MANUAL VALVES

- A. Metal Seated Gate Valves
 - 1. Mueller, Series A-2380
 - 2. Clow, Double Disc Gate Valve
 - 3. Kennedy Valve, Double Disc Gate Valve
- B. Butterfly Valves
 - 1. Pratt
 - 2. Dezurik
- C. Resilient Seated Gate Valves
 - 1. Clow RW 2639 and 2640
 - 2. American Flow Control Series 2500
 - 3. Kennedy Valve, AWWA C-509
 - 4. American AVK Co., Series 45 and 65
 - 5. Mueller Series A-2360
 - 6. U.S. Pipe A-USP1
- D. Valve Boxes
 - 1. South Bay Foundry - 1208N WATER

SECTION 15139 FIRE HYDRANTS

- A. Wet Barrel Fire Hydrants
 - 1. Jones J-3710 8-hole Fire Hydrant P/C Safety Yellow
 - 2. Clow Model 2050
- B. Wet Barrel Fire “Super Hydrants”
 - 1. Clow Model 2065

SECTION 15150 METERS

- A. Customer Meters and Fire Service Bypass Meters (3/4-inch through 1-inch)
 - 1. Sensus iPerl
- B. Customer Meter (1-1/2 inch through 2 inch)
 - 1. Kamstrup flowIQ 3101
- C. Commercial Customer Meters (3-inch through 8-inch)
 - 1. Sensus Omni Compound (C2)
- D. Irrigation Customer Meters (3-inch through 8-inch) and Commercial Bypass Meters (2-inch)
 - 1. Sensus Omni Turbo (T2)
- E. Propeller Flowmeters
 - 1. McCrometer
- F. Magnetic Flowmeters
 - 1. Toshiba

SECTION 15151 POTABLE WATER, RECYCLED WATER, AND WASTEWATER FACILITIES IDENTIFICATION

- A. Warning Tape and Pipe Sleeves
 - 1. Griffolyn Company, Inc.
 - 2. Terra Tape, Division of Reef Industries
 - 3. T. Christy Enterprises, Inc.
- B. Witness Markers
 - 1. Carsonite Water line Markers

SECTION 15162 PIPE COUPLINGS AND ADAPTERS

- A. Sleeve-Type Couplings
 - 1. Baker
 - 2. Romac
 - 3. Smith-Blair
- B. Restrained Sleeve-Type Couplings
 - 1. Ebaa Iron
 - 2. Romac

- 3. Smith-Blair
- C. Restrained One-Piece Coupling
 - 1. Romac

SECTION 15170 WALL AND SLAB PENETRATIONS

- A. Wall Pipe Modular Seals
 - 1. GPT Industries

SECTION 15300 AUTOMATIC CONTROL VALVES

- A. Check Valves
 - 1. Cla-Val model 81G-02KC with X101 Valve Position Indicator (installed by valve manufacturer)
 - 2. Singer model 106-HC
- B. Solenoid Control Valves
 - 1. Cla-Val model 136G-03 YBCSFKC with Limit Switch Assembly Model X105LCW (installed by valve manufacturer)
 - 2. Singer model 106-2SC-PCO
- C. Pressure Reducing Valves
 - 1. Cla-Val model 90G-01YBKC (90G-01YSFC for valves 3 inches and smaller), with X101 Valve Position Indicator (installed by valve manufacturer)
 - 2. Singer model 106-PR
- D. Pressure Relief Valves
 - 1. Cla-Val model 50G-01SBKC with Limit Switch Assembly Model X105LOW (installed by valve manufacturer)
 - 2. Singer model 106-BPC
- E. Surge Anticipator Valves
 - 1. Cla-Val model 52G-01BKC with Limit Switch Assembly Model X105LOW (installed by valve manufacturer)
 - 2. Singer model 106-RPS-L&H
- F. Pump Controller Valves
 - 1. Cla-Val model 60G-11 BKC with Limit Switch Assembly Model X105LCW (installed by valve manufacturer)
 - 2. Singer model 106-PG-BPC

G. Altitude Valves

1. Cla-Val model 201-01 with X-101 position indicator
2. Singer model 106-A-Type 3 with X-107 position indicator

PIPE SUPPORTS

- A. Grinnel No. 264

ELECTRICAL COMPONENTS

A. Motors

1. U.S. Motors
2. Baldor – Reliance
3. WEG

B. Automatic Transfer Switches

1. ASCO, 940 Series

C. Electric Actuators

1. Rotork
2. AUMA

D. Motor Control Centers and Drives

1. Allen-Bradley (no exceptions)

INSTRUMENTATION

A. Pressure Transmitters

1. Rosemount, 2051 Smart

B. Level Transmitter

1. Rosemount, 5300
2. Multitrode Level Probe

C. Gas Detectors

1. MSA

D. Pump Control Panels

1. FW Murphy

- E. Programmable Logic Controllers
 - 1. Allen-Bradley (no exceptions)